

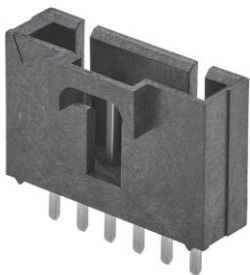

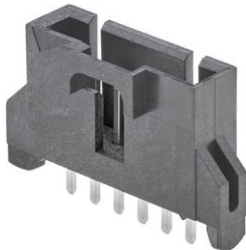

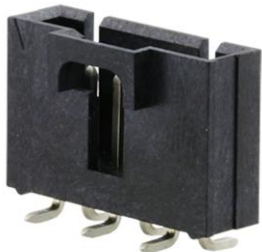

PRODUCT SPECIFICATION

SL SHROUDED HEADERS

SL VERTICAL HEADERS

THROUGH HOLE	THROUGH HOLE WITH PEGS	SMT
		
SERIES 171971	SERIES 171972	SERIES 171973

SL RIGHT ANGLE HEADERS

THROUGH HOLE	THROUGH HOLE WITH PEGS
	
SERIES 171974	SERIES 171975
SMT	SMT WITH PEGS
	
SERIES 171976	SERIES 171977

REVISION: A1	ADD PHOTOS EC No: 176221 DATE: 2018-06-11	TITLE: PRODUCT SPECIFICATION SL SHROUDED HEADERS	SHEET No. 1 of 3
DOCUMENT NUMBER: 1719710000-PS	DOC TYPE: PS	DOC PART: 000	CREATED / REVISED BY: KSAMIEC
	CHECKED BY: KSAMIEC	APPROVED BY: FSMITH	



PRODUCT SPECIFICATION

SL SHROUDED HEADERS

1.0 SCOPE

This Product Specification covers the SL 2.54 millimeter centerline SL Shrouded Header Assemblies

2.0 PRODUCT DESCRIPTION

2.1 PRODUCT SERIES AND DESCRIPTION

SERIES	DESCRIPTION
171971	SL Vertical Shrouded Header Assy Thru Hole no Pegs
171972	SL Vertical Shrouded Header Assy Thru Hole with Pegs
171973	SL Vertical Shrouded Header Assy SMT no Pegs
171974	SL Right Angle Shrouded Header Assy Thru Hole no Pegs
171975	SL Right Angle Shrouded Header Assy Thru Hole with Pegs
171976	SL Right Angle Shrouded Header Assy SMT no Pegs
171977	SL Right Angle Shrouded Header Assy SMT with Pegs

2.2 DIMENSIONS, MATERIALS, PLATINGS AND MARKINGS

- 2.2.1 Header Material: LCP, Black, UL94V-0
- 2.2.2 Mating Pin Length: 6.10 millimeters
- 2.2.3 Thru Hole PCB Tail Length: 3.30 millimeters.
- 2.2.4 Recommended PCB Thickness: 1.57 millimeters.
- 2.2.4 Available in the following Finishes: Overall Matte Tin or Select Gold
- 2.2.5 See the appropriate Sales Drawing(s) for additional information on dimensions and markings.

2.3 SAFETY AGENCY APPROVALS

- 2.3.1 Underwriters Laboratory: UL E29179
- 2.3.2 Canadian Standards Association: CSA LR19980

3.0 APPLICABLE DOCUMENTS AND SPECIFICATIONS

3.1 SOLDERABILITY: Per SMES-152 Lead Free Process

- 3.1.1 Process: Wave or Reflow
- 3.1.2 Peak Temperature: 260°C Maximum
- 3.1.3 Time within 5°C of peak Temperature: 40 seconds Maximum
- 3.1.4 Cycles: 3 cycles thru solder process Maximum

4.0 RATINGS

4.1 VOLTAGE: 250 Volts

4.2 CURRENT: 3.0 Amps Maximum

- Current is dependent on connector size, contact material, plating, ambient temperature, printed circuit board characteristics and related factors. Actual current rating is application dependent and should be evaluated for each application.
- Note: Current Ratings are for a single circuit, based on not exceeding 30°C temperature rise.

4.3 TEMPERATURE: (ambient +30°C)

- Operating Temperature: -40°C to +105°C
- Non-Operating Temperature: -30°C to +105°C

REVISION: A1	ADD PHOTOS EC No: 176221 DATE: 2018-06-11	TITLE: PRODUCT SPECIFICATION SL SHROUDED HEADERS	SHEET No. 2 of 3
DOCUMENT NUMBER: 1719710000-PS	DOC TYPE: PS	DOC PART: 000	CREATED / REVISED BY: KSAMIEC
	CHECKED BY: KSAMIEC	APPROVED BY: FSMITH	



PRODUCT SPECIFICATION

SL SHROUDED HEADERS

5.0 PERFORMANCE

5.1 ELECTRICAL REQUIREMENTS

ITEM	DESCRIPTION	Test Condition	Requirement
1	Insulation Resistance	Unmate & unmount connectors: apply a voltage of 500 VDC between adjacent terminals and between terminals to ground.	1000 Mega-ohms Minimum
2	Dielectric Withstanding Voltage	Unmate connectors: apply a voltage of {two times the rated voltage plus 1000 volts} VAC for 1 minute between adjacent terminals and between terminals to ground.	No Breakdown, Current leakage < 5 mA

5.2 MECHANICAL REQUIREMENTS

ITEM	DESCRIPTION	Test Condition	Requirement
3	Pin Retention Force (in Header)	Axial pullout force on the pin in the housing at a rate of 25 ± 6 mm per minute.	17.8 Newton Minimum retention force
4	Tri-Peg Insertion Force (in PCB)	Recommended Hole size 3.40 ± 0.05 mm Insert connector at a rate of 25 ± 6 mm per minute.	44.5 Newton MAXIMUM insertion force
5	Tri-Peg Retention Force (in PCB)	Recommended Hole size 3.40 ± 0.05 mm. Pull connector at a rate of 25 ± 6 mm per minute.	4.5 Newton MINIMUM retention force
6	Pin Retention Force after Wave Solder	Apply a wave solder process of 260°C maximum. Axial pullout force on the housing at a rate of 25 ± 6 mm per minute.	13.3 Newton Minimum retention force

5.3 ENVIRONMENTAL REQUIREMENTS:

ITEM	DESCRIPTION	Test Condition	Requirement
9	Shock (Thermal)	Expose to 10 cycles of: <u>Temperature °C</u> <u>Duration (Minutes)</u> -40 +0/-3 30 +105 +3/-0 30 Per IEC 68-2-14.	Visual: No Damage
10	Thermal Aging	Expose to: 240 hours at 105 ± 2°C Per MIL-STD-202F Method 108A.	Visual: No Damage
11	Humidity (Steady State)	Expose to temperature of 40 ± 3°C at 96 ± 5% relative humidity for 240 hours. Per MIL-STD-202F Method 108A Test Condition A.	Visual: No Damage
12	Flowers of Sulphur	Exposed to sulphur vapors for 24 hours at 65 ± 3°C. Per IEC 68-2-42.	Visual: No Damage

6.0 PACKAGING:

See individual drawings for packaging specification.

REVISION: A1	ADD PHOTOS EC No: 176221 DATE: 2018-06-11	TITLE: PRODUCT SPECIFICATION SL SHROUDED HEADERS	SHEET No. 3 of 3
DOCUMENT NUMBER: 1719710000-PS	DOC TYPE: PS	DOC PART: 000	CREATED / REVISED BY: KSAMIEC
	CHECKED BY: KSAMIEC	APPROVED BY: FSMITH	