

# 4Discovery-35

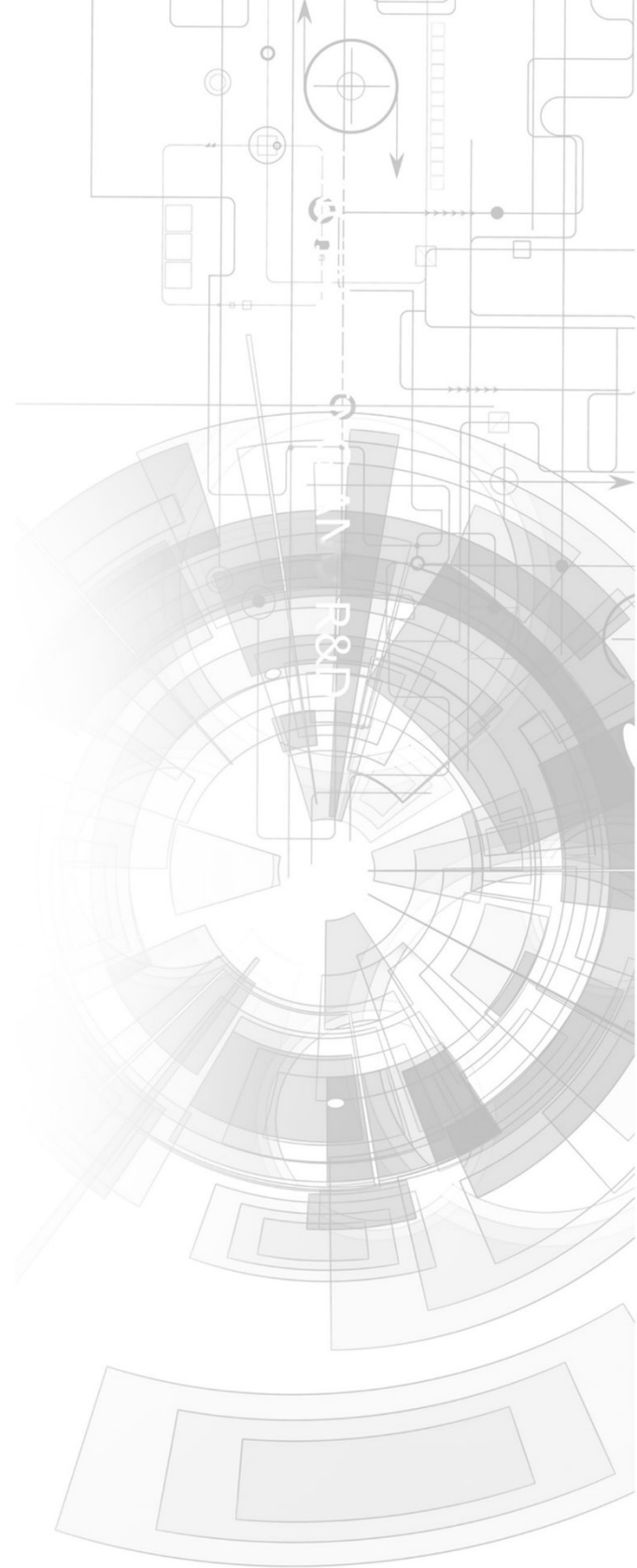

## Datasheet

Revision 2.4

Copyright © 2023 4D Systems

Content may change at any time. Please refer to the resource centre for latest documentation.

# Contents

---

1. Description	4
2. Features	5
3. RJ45 Pin Configuration and Summary	6
4. Hardware Interface - Pins	7
4.1. Serial Ports - RS85	7
4.2. System Pins	8
5. PmmC/Firmware Programming	9
6. Module Features	9
6.1. Display - 3.5" TFT Touch Screen	9
6.2. DIABLO16 Processor	10
6.3. SD/SDHC Memory Cards	10
6.4. FAT16	11
6.5. Serial Flash Memory (Optional)	11
6.6. Real-Time Clock (Optional)	12
6.7. Crypto Authenticate (Optional)	12
6.8. Piezo Buzzer	12
6.9. Universal Mounting Options	13
6.10. Removable Front Cover	14
6.11. Removable Display subassembly	14
7. Display Precautions	15
8. Hardware Tools	16
8.1. 4D 485 Programmer	16
9. Programming Language	17
10. Workshop4 IDE	18
10.1. ViSi-Genie Limitations with 4Discovery	19
11. Connecting to External Hardware	20
11.1. Master and Slaves	20

11.2. 4Discovery as a Host	21
11.3. 4Discovery as a Slave	22
11.4. 4Discovery Multiple Masters	24
11.5. Programming 4Discovery	25
11.6. Termination Resistors	26
12. Mechanical Details	27
13. Schematic Details - HW REV 2.7	28
14. Schematic Details - HW REV 4.0	29
15. Schematic Details - HW REV 4.2	30
16. Specifications	31
17. Revision History	32

# 1. Description

The 4Discovery is a high-resolution 480x320 pixel 3.5" Intelligent wall-mounted display product from 4D Systems, featuring the DIABLO16 Processor.

The 4Discovery is designed to be mounted to a standard light switch flush/mounting box, or directly onto a panel or wall. This universal mounting enables quick and easy installation almost anywhere, such as on a wall or into an enclosure or panel, enabling a wide range of customers to take advantage of this display product.

Driving the display and peripherals is the DIABLO16 processor, a very capable and powerful chip that enables stand-alone functionality, programmed using the 4D Systems Workshop4 IDE Software. The Workshop IDE enables graphic solutions to be constructed rapidly and with ease due to its design being solely for 4D graphics processors.

The 4Discovery has an array of features including a 3.5" 320x480 TFT LCD Display, Resistive Touch, micro-SD memory storage, 2 wire RS485 Interface which can act as Master or Slave with additional changeover wire, and a switch-mode power supply enabling a wide input voltage range, along with many more features.

Anything that has been designed to run on a PICASO or DIABLO16 module can theoretically run on this 4Discovery with minor changes. Please ensure you contact the 4D Systems' support team if unsure about changing over from a 4D Systems module to this 4Discovery.

## 2. Features

- Powerful 3.5" Intelligent LCD-TFT display module powered by DIABLO16.
- 480x320 HVGA Resolution, RGB 65K true-to-life colours, TFT Screen with integrated 4-wire Resistive Touch Panel.
- Programmed over RS485 using a special programmer designed specifically for the 4Discovery.
- 6 banks of 32750 bytes of Flash memory for User Application Code and Data
- 32Kb of SRAM purely for the User.
- On-board micro-SD memory card connector for multimedia storage and data logging purposes. HC memory card support is also available for cards larger than 4GB.
- DOS-compatible file access (FAT16 format) as well as low-level access to microSD card memory.
- Display full colour images, animations, icons and video clips on chosen 4D Systems display.
- Supports all available Windows fonts.
- 5.0V or 7.0V to 30V input voltage range operation (single supply).
- Module dimensions: 74.0 x 117.0 x 21.7mm
- Weight approximately 80g.
- Display Viewing Area: 48.96 x 73.44mm
- Easily mounted to the wall using a standard light switch flush/mounting box, or can be mounted in an enclosure/panel or virtually any flat drillable surface.
- Compatible with Clipsal/HPM mounting blocks, 18mm or thicker, if the 4Discovery needs to be offset from the wall (useful for concrete block walls etc).
- RoHS and CE Compliant

### 3. RJ45 Pin Configuration and Summary

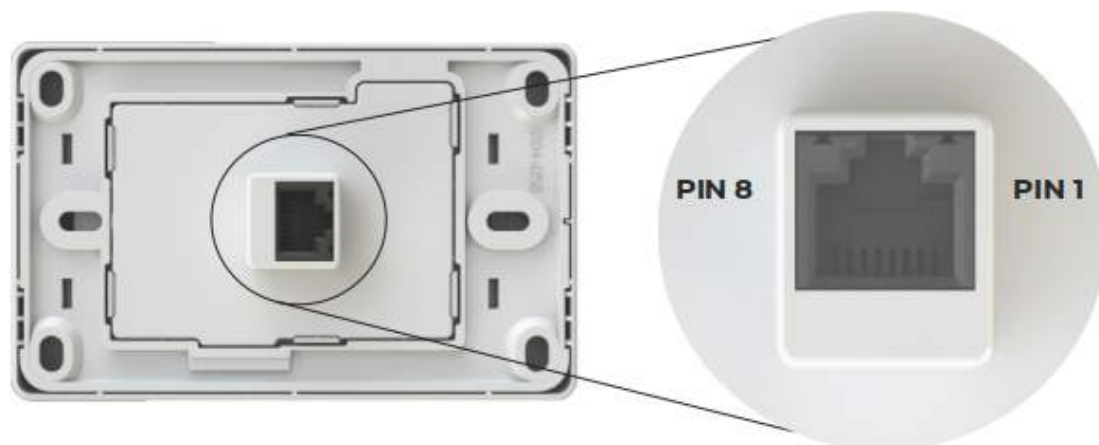

#### RJ45 Pinout

Pin	Symbol	I/O	Description
1	VIN	P	7.0V to 30VDC Input. Recommended range is 12V to 24V. This is the primary power source of the 4Discovery.
2	A	I/O	485 A Signal (non-Inverting) pulled to 3.3V internally, terminated to B with 120Ω.
3	B	I/O	485 B Signal (Inverting), pulled to GND internally, terminated to A with 120Ω.
4	GND	P	System Ground, relevant to VIN and 5V_IN
5	GND	P	System Ground, relevant to VIN and 5V_IN
6	5V_IN	P	5.0VDC Input. This is typically only used to power the 4Discovery from the 4D 485 Programmer, however, can be used to power the 4Discovery if a higher voltage power source into VIN is not available. Should be in the range of 4.5V to 5.5V, nominal 5.0V
7	TURN	I	Primarily used by the 4D 485 Programmer in conjunction with programming the 4Discovery, however, can also be from an external device that is acting as a Host when 4Discovery is programmed to be a slave. This is an input only to the 4Discovery. When 4Discovery is a Master, the slaves have to determine the direction of transmit/receive themselves using an Auto Turnaround 485 IC or circuit.
8	RESET	I	Reset signal used by the 4D 485 Programmer. Can be used by an external device if the 4Discovery needs to be reset. Active Low.

#### Note

**I** = Input, **O** = Output, **P** = Power

## 4. Hardware Interface - Pins

The 4Discovery provides both a hardware and software interface. This section describes in detail the hardware interface pins of the device.

### 4.1. Serial Ports - RS85

The 4Discovery provides one asynchronous serial port that interfaces via the RJ45 port and communicates using the RS485 protocol.

This serial port is used for both communications to various devices on the RS485 bus, and also for the programming of the 4Discovery itself, using the 4D 485 Programmer.

A MAX3430 RS485 IC is used inside the 4Discovery, to provide the RS485 interface, signals A and B.

The primary features are:

- Full-Duplex 8-bit data transmission and reception.
- Data format: 8 bits, No Parity, 1 Stop bit.
- Baud rates from 300 baud up to 250K baud.
- Single byte transmits and receives a fully buffered service. The buffered service feature runs in the background capturing and buffering serial data without the user application having to constantly poll any of the serial ports. This frees up the application to service other tasks.

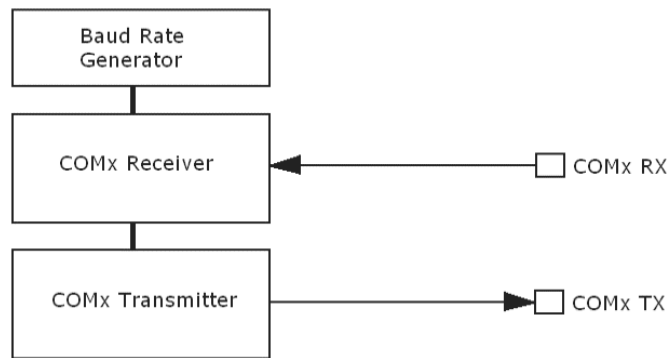

A single-byte serial transmission consists of the start bit, 8 bits of data followed by the stop bit. The start bit is always 0, while a stop bit is always 1. The LSB (Least Significant Bit, Bit 0) is sent out first following the start bit.

The figure below shows a single-byte transmission timing diagram.

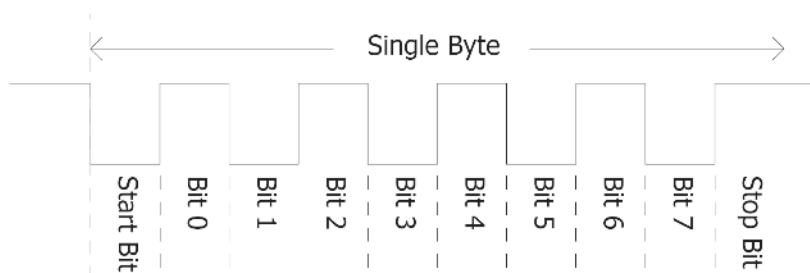

## 4.2. System Pins

### **VIN (Primary Voltage Input):** *Pin 1*

4Discovery supply voltage input pin. This pin must be supplied between 7.0VDC and 30VDC, and these must not be exceeded. Typical voltages are between 12V and 24VDC. If this pin is not used, a 5VDC source can be applied to pin 6 instead.

### **A (485 A Signal):** *Pin 2*

This is the A signal used by the 2-wire RS485 bus on the 4Discovery. This signal is internally pulled up to 3.3V to prevent a floating bus and is terminated to the B signal with a 120Ω resistor.

### **B (485 B Signal):** *Pin 3*

This is the B signal used by the 2-wire RS485 bus on the 4Discovery. This signal is internally pulled down to GND to prevent a floating bus and is terminated to the A signal with a 120Ω resistor.

### **GND (Module Ground):** *Pins 4 and 5*

Device ground pins. At least one of these pins must be connected to the ground.

### **5V\_IN (Secondary Voltage Input):** *Pin 6*

4Discovery supply voltage input pin. This pin is typically used by the 4D 485 Programmer when programming from the USB of a PC, however, it can also be used in the case a suitable voltage cannot be applied to VIN. Supply to this pin must be between 4.5V to 5.5V DC. The nominal operating voltage is 5.0 Volts.

 **Note**

Backlight brightness will be lower for voltages under 5.0V.

### **TURN (485 Turn Around Pin):** *Pin 7*

Primarily used by the 4D 485 Programmer in conjunction with programming the 4Discovery, however, can also be from an external device that is acting as Host when 4Discovery is programmed to be a slave. This is an input only to the 4Discovery. When 4Discovery is a Master, the slaves have to determine the direction of transmit/receive themselves using an Auto Turnaround 485 IC or circuit.

### **RESET (Module Master Reset):** *Pin 8*

Reset signal used by the 4D 485 Programmer. This can be used by an external device if the 4Discovery needs to be reset. Active Low.



## 5. PmmC/Firmware Programming

The 4Discovery features a 4D Systems DIABLO16 processor, which is a custom graphics processor. All functionality including the high-level commands is built into the chip. This chip-level configuration is available as a PmmC (Personality-module-micro-Code) file, which can be likened to traditional Firmware. There is also a Display Driver file, which separates specific display settings from the PmmC.

A PmmC file contains all of the low-level micro-code information (analogy of that of a soft silicon) which defines the characteristics and functionality of the device. The ability of programming the device with a PmmC file provides an extremely flexible method of customising as well as upgrading it with future enhancements.

The Display Driver contains the initialisation and parameters associated with the particular display that is to be connected to the DIABLO16 processor. The PmmC file and Display Driver file can only be programmed into the device using the RJ45 connector, using the 4D 485 Programmer with the aid of Workshop4, the 4D Systems IDE software.

You must use the 4D 485 Programmer. No other RS485 device will be able to program the 4Discovery.

## 6. Module Features

The 4Discovery is designed to accommodate a range of wall or enclosure-mounted applications. Some of the main features of the 4Discovery are listed below.

### 6.1. Display - 3.5" TFT Touch Screen

The 4Discovery is equipped with a 3.5" TFT display. Details of the display are listed below:

- Screen Size:
  - 3.5" diagonal
  - 320x480 resolution
  - 65K colours
- Viewing Area: 48.96 x 73.44mm
- Pixel Pitch: 0.153(H) x 0.153(V)mm
- Brightness: 220cd/m<sup>2</sup>
- Viewing Angle:
  - Above Centre: 65 degrees
  - Below Centre: 45 degrees
  - Left of Centre: 60 degrees
  - Right of Centre: 60 degrees
- Viewing Direction: 12 O'clock
- Contrast Ratio: 500:1
- 7 LEDs for Backlighting

#### Note

The Displays used are the highest-rated 'Grade A' Displays, which allow for 0-4 defective pixels. A defective pixel could be solid Black (Dead), White, Red, Green or Blue.

## 6.2. DIABLO16 Processor

The 4Discovery is designed around the DIABLO16 Graphics Controller from 4D-Labs.



The DIABLO16 is a smart Controller and the interface to the TFT- LCDs is almost plug-n-play. All of the data and control signals are provided by the chip to interface directly with the display.

Powerful graphics, text, images, animation and countless more features are built right inside the chip.

You can refer to the [DIABLO16 processor datasheet](#) for more information.

## 6.3. SD/SDHC Memory Cards

The 4Discovery supports micro-SD memory cards via the onboard micro-SD connector. The memory card is used for all multimedia file retrieval such as images, animations and movie clips. The memory card can also be used as general-purpose storage for data logging applications. Support is available for off-the-shelf micro-SD (up to 2GB) and high-capacity SDHC memory cards (4GB and above).



### Note

A microSD card capable of SPI is a requirement for all 4D Systems' display modules powered by Goldelox, Picaso or Diablo16 Processors. If a non-SPI compatible card is used, it will simply fail to mount, or may cause intermittent issues resulting in lockups and crashing of the application. Please refer to the 4D Systems website for microSD cards offered by 4D Systems.

The micro-SD card can be used as an update medium for the 4Discovery, in conjunction with suitable application code being written. The MicroSD card can be mounted and used to update the application(s) stored on the onboard Flash of Diablo16. This is useful to roll out updates without having to reprogram the 4Discovery. This however is not able to update the PmmC/Firmware or

Display Driver. These must still be updated via the RS485 Programmer or over the network with a suitable Host code.

The 4Discovery features a Card Detect on the microSD socket, which can be utilised by the User in their application, to determine if a microSD card is inserted or not.

#### **PA11** - Card Detect

PA11 is Active Low when a card is detected, and High when no card is detected.

## **6.4. FAT16**

The uLCD-35DT Module uses off-the-shelf standard SDHC/SD/micro-SD memory cards with up to 4GB capacity usable with FAT16 formatting. For any FAT file-related operations, before the memory card can be used it must first be formatted with the FAT16 option. The formatting of the card can be done on any PC system with a card reader. Select the appropriate drive and choose the FAT16 (or just FAT in some systems) option when formatting. The card is now ready to be used in the DIABLO16-based application.

The DIABLO16 Processor also supports high-capacity HC memory cards (4GB and above). The available capacity of SD-HC cards varies according to the way the card is partitioned and the commands used to access it.

The FAT partition is always first (if it exists) and can be up to the maximum size permitted by FAT16. Windows 7 will format FAT16 up to 4GB. Windows XP will format FAT16 up to 2GB and the Windows XP command prompt will format FAT16 up to 4GB.

Partitioning of microSD cards should be carried out using the RMPET tool, which is included with the Workshop4 IDE. This tool enables you to partition and format your microSD card in a range of ways. It also then allows you to format the card so it is ready for the 4Discovery.

## **6.5. Serial Flash Memory (Optional)**

The 4Discovery features an optional 128Mbit (16MB) of Serial Flash Memory which is connected to the following GPIO:

- **PA0** - SPI Chip Select
- **PA1** - SPI Clock
- **PA2** - SPI Data Out MOSI
- **PA3** - SPI Data In MISO

DIABLO16 has a set of built-in user functions to address SPI Flash Memory.

For more information on the SPI functions, please refer to the [Diablo16 Internal Functions Manual](#).

To order the 4Discovery-35 with Flash installed, please contact our Sales Team.

## 6.6. Real-Time Clock (Optional)

The 4Discovery features an optional Microchip MCP7940N real-time clock. This RTC is capable of Day, Month, Year, Hour, Minute, Seconds and Day of Week, with leap year compensation up to the year 2399, and both 12 and 24-hour modes.

This RTC communicates to the DIABLO16 processor over an I2C interface using the following GPIO:

- **PA13** - I2C Data SDA
- **PA12** - I2C Clock SCL

It is capable of up to 400 kHz I2C communications. For more information on the I2C functions, please refer to the [Diablo16 Internal Functions Manual](#).

To order the 4Discovery-35 with RTC installed, please contact our Sales Team.

## 6.7. Crypto Authenticate (Optional)

4Discovery features an optional Atmel Crypto Authentication security chip, which enables Diablo16 to encode messages securely so the messages cannot be intercepted and read openly by a 3rd party without difficulty.

It also gives you the ability to have a unique ID for the 4Discovery, so when using multiple on a BUS there is a hard-coded ID generated by the Crypto Authentication chip which is unique.

The Crypto Authentication chip uses the following GPIO:

- **PA14** - I2C Clock SCL
- **PA15** - I2C Data SDA

It is capable of up to 1 MHz I2C Communications. For more information on the I2C functions, please refer to the [Diablo16 Internal Functions Manual](#).

To order the 4Discovery-35 with Crypto Authentication installed, please contact our Sales Team.

## 6.8. Piezo Buzzer

The 4Discovery has an onboard Piezo buzzer, which enables feedback to the user for a range of situations, such as when the screen is touched, or if an event occurs that needs an audio alert.

The Piezo buzzer uses the AUDIO pin on the Diablo16 processor and can be controlled using the **snd\_Freq()** function. The optimal frequency to use for this buzzer is 2731Hz.

For more information on this function, please refer to the [Diablo16 Internal Functions Manual](#).

## 6.9. Universal Mounting Options

The 4Discovery has a range of ways it can be mounted. Primarily designed to be mounted into a standard light switch frame (a.k.a. Flush Box, Mounting Box), it can also be panel or enclosure mounted, or directly mounted on virtually any supportive wall surface. This includes plasterboard, wood, and even concrete.

One nice feature about the 4Discovery is only a single central hole is required to be drilled into the surface to enable the CAT5 cable to pass through and the RJ45 socket on the back of the 4Discovery to protrude into. Mounting can then be as little as 2 screws, depending on the mounting surface.

The central hole needs to be larger than 25mm (about 1") to give the RJ45 socket sufficient clearance and not bind in the hole.

There are 4 corner mounting slots, designed for countersunk self-tapping wood screws or similar. 8G Countersunk Head chipboard screws work well.

There are 2 central mounting slots, designed for the Flush/Mounting box which are commonly used for Plaster Board installations. Typically the screws that come with the Flush/Mounting box are used and are Pan Head type.

Any of these 6 mounting holes however can be used to mount the 4Discovery. Select the most appropriate ones for your target installation, and ensure the 4Discovery is securely attached to the surface in question.

Please refer to the mechanical drawing towards the end of this document, for more information regarding the mounting holes and positions.

## 6.10. Removable Front Cover

The front cover of the 4Discovery is removable to access the mounting holes beneath it. Simply clip on or unclip the cover as required.



On the front cover is a recessed area at the top left. This is countersunk slightly into the surface and is designed so a company logo sticker can be placed in this location, to customise the 4Discovery to suit the application it is being used in. Bubble Stickers work well and give a nice 3D look.

### Note

By default, starting with Revision 4.0, the plastics will be shipped without any branding in this area, and a recess. Previous revisions featured 4Discovery branding in a recess which could then be covered.



## 6.11. Removable Display subassembly

The display module itself can be removed from the mounting base, which enables full access to all of the mounting holes, specifically the 2 central slots, designed for a Flush/Mounting box.

The display module can be carefully unclipped by gently raising the two upper (or lower) clips, which will release the display module from the mounting base. Please ensure only gentle force is applied to these clips so they are not damaged.



## 7. Display Precautions

- Avoid having to display the same image/object on the screen for lengthy periods. This will cause a burn-in which is a common problem with all types of display technologies. Blank the screen after a while or dim it very low by adjusting the contrast. Better still; implement a screen saver feature.
- Moisture and water can damage the display. Moisture on the surface of a powered display may cause the electrodes to corrode. Wipe off any moisture gently or let the display dry before usage.
- Dirt from fingerprint oil and fat can easily stain the surface of the display. Gently wipe off any stains with a soft lint-free cloth.
- The performance of the display will degrade under high temperatures and humidity. Avoid such conditions when storing.
- Displays are susceptible to mechanical shock and any force exerted on the module may result in deformed zebra stripes, a cracked display cell and a broken backlight
- Always use the mounting holes on the 4Discovery when mounting the 4Discovery to a wall, enclosure or panel.
- Do not apply undue tightness to the screws when fixing the 4Discovery to the chosen wall/ enclosure, the 4Discovery case is made of plastic and may be damaged if screws are fastened too tightly.

## 8. Hardware Tools

The following hardware tools are required for full control of the 4Discovery module.

### 8.1. 4D 485 Programmer

The 4D 485 Programmer is an essential hardware tool to program, customise and test the 4Discovery module.

It is possible to change the application the 4Discovery is running, using a microSD card. This however is only possible once the 4Discovery has been programmed such that the application can update itself. This is not possible out of the box and requires an appropriate program to be written to achieve this.

The 4D 485 Programmer is used to program a new Firmware/PmmC, Display Driver and for transferring compiled Workshop4 Applications. It can even serve as an interface for communicating serial data to the PC. The 4D Programmer also supplies power to the 4Discovery so it can be programmed on the bench or in the field, as it must be disconnected from the RS485 network to be programmed with the 4D 485 Programmer and therefore needs a power source.

Connecting the 4D 485 Programmer to the 4Discovery, requires a standard CAT5 Ethernet cable, straight through (NOT cross over). You can use CAT4, CAT5, CAT5e, CAT6 etc type cables, but all that is required is 8 wires/conductors and these are straight through, not crossed, to allow correct connection between the two RJ45 plugs/connectors on the 4Discovery and the 4D 485 Programmer. The speed rating of Ethernet cables is not relevant for the 4Discovery since it uses RS485 which operates at a much slower speed than Ethernet.

The maximum length of cable between the 4Discovery and the 4D 485 Programmer, should be kept below 10m. This is due to TTL signals on the RJ45 connector that needs to be controlled by the 4D 485 Programmer. Anything longer may be feasible depending on the type of cable used, however, typically longer cables will cause voltage drops and capacitive loading which could cause programming to fail.

#### Note

The 4Discovery cannot be programmed when connected to the RS485 network. It needs to be 1:1 with the 4D 485 Programmer.



## 9. Programming Language

The 4Discovery utilises the DIABLO16 processor, which belongs to a family of processors powered by a highly optimised softcore virtual engine, EVE (Extensible Virtual Engine).

EVE is a proprietary, high-performance virtual machine with an extensive byte-code instruction set optimised to execute compiled 4DGL programs. 4DGL (4D Graphics Language) was specifically developed from the ground up for the EVE engine core. It is a high-level language that is easy to learn and simple to understand yet powerful enough to tackle many embedded graphics applications.

4DGL is a graphics-oriented language allowing rapid application development, and the syntax structure was designed using elements of popular languages such as C, Basic, Pascal and others.

Programmers familiar with these languages will feel right at home with 4DGL. It includes many familiar instructions such as `IF..ELSE..ENDIF`,

`WHILE..WEND`, `REPEAT..UNTIL`, `GOSUB..ENDSUB`, `GOTO`, `PRINT` as well as some specialised instructions `SERIN`, `SEROUT`, `GFX_LINE`, `GFX_CIRCLE` and many more.

For detailed information about the 4DGL language, please refer to the following documents:

- [4DGL Programmers Reference Manual](#)
- [Diablo16 Internal Functions Manual](#)

To assist with the development of 4DGL applications, the Workshop4 IDE combines a full-featured editor, a compiler, a linker and a downloader into a single PC-based application. It's all you need to code, test and run your applications.

4DGL is available to be written in two of the four environments offered by the Workshop4 IDE, Designer and ViSi. The other two environments, Serial and ViSi-Genie do not directly use 4DGL by the User (Except in Workshop4 Pro, for ViSi-Genie), however, it is present in the background. Serial is an application that runs, and that is written in 4DGL. ViSi-Genie automatically generates 4DGL itself based on what is configured in the GUI.

## 10. Workshop4 IDE

Workshop4 is a comprehensive software IDE that provides an integrated software development platform for all of the 4D family of processors and modules. The IDE combines the Editor, Compiler, Linker and Down-Loader to develop complete 4DGL application code. All user application code is developed within the Workshop4 IDE.

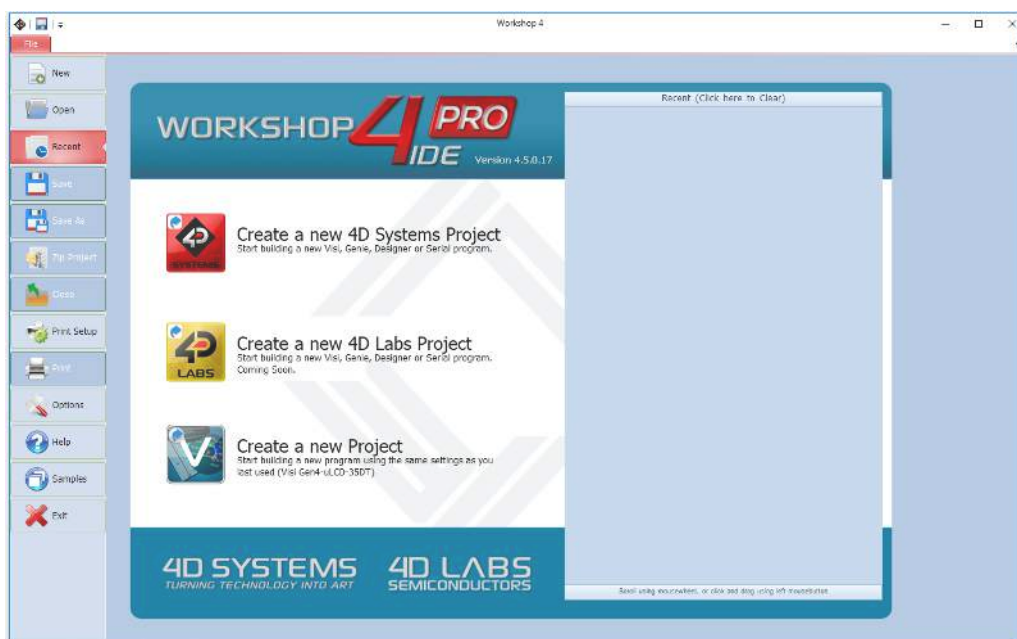

The Workshop4 IDE supports multiple development environments for the user, to cater to different user requirements and skill levels.

- The **Designer** environment enables the user to write 4DGL code in its natural form to program the 4D display module.
- A visual programming experience, suitably called **ViSi**, enables drag-and-drop type placement of objects to assist with 4DGL code generation and allows the user to visualise how the display will look while being developed.
- An advanced environment called **ViSi-Genie** doesn't require any 4DGL coding at all, it is all done automatically for you. Simply lay the display out with the objects you want, set the events to drive them and the code is written for you automatically. ViSi-Genie provides the latest rapid development experience from 4D Systems.
- A **Serial** environment is also provided to transform the display module into a slave serial module, allowing the user to control the display from any host microcontroller or device with a serial port.

For more information regarding these environments, refer to the [Workshop4 manuals](#).

The Workshop 4 IDE is available from the [4D Systems website](#).

## 10.1. ViSi-Genie Limitations with 4Discovery

While the 4Discovery is capable of being programmed using the basic ViSi-Genie Environment, some limitations need to be observed. If the 4Discovery is being programmed as a Slave Device on the RS485 network, it can only function in Polled mode, rather than Event mode due to the RS485 interface being half-duplex rather than a full duplex. 2-wire RS485 is only half duplex. If the 4Discovery is being programmed as a Master Device (Host) on the RS485 network, it can operate using Event mode, however, is limited in data that can be returned from the slaves.

When the 4Discovery is used with the basic ViSi-Genie, only a single Master/Host and a single Slave can be present on the network. This is the limitation with the ViSi-Genie protocol, as there is no way to direct the ViSi-Genie protocol to a specific Slave, and there is no way for Half Duplex RS485 to handle the responses from the slaves. If more than 1:1 is required, another Environment such as ViSi will be required.

If the basic ViSi-Genie is to be used when operating as a Slave Device, which is the typical operation for a 4D display using ViSi-Genie, when selecting the Event options on any given widget/object, "Reported Messages" cannot be used. The Host must poll each object on the 4Discovery to gain the required information. 4Discovery cannot just send information when it likes, which is the case of Reported Messages, as the 4Discovery is a Slave and therefore is only allowed to speak when spoken to.

If the basic ViSi-Genie is to be used when operating as a Host Device, the Reported Message option can be used as it can speak out to the bus as required since it is the Master of the RS485 bus. However, it is not possible to request information from Slave devices, such as the value of something, as there are no standard functions available in ViSi-Genie to request data from another device. This mode is typically only useful if the 4Discovery only features controls such as buttons, switches, sliders and knobs, which do not require data to be displayed, and only send data out to the slaves for them to do a specific function. Therefore, it has limited but still applicable applications.

Workshop4 PRO has an advanced ViSi-Genie environment with new widgets which allow 4DGL code to be executed by the ViSi-Genie environment when various situations occur, such as button presses, data being received, touchscreen interaction, etc. With Workshop4 PRO, a number of the above limitations are lifted and therefore possible.

4D Systems has ViSi-Genie libraries for the Arduino and the Raspberry Pi. The Arduino library has been updated to include support for the 4Discovery, to allow it to communicate as a Slave to an Arduino using RS485 (external hardware is required on the Arduino). It utilises the Turn Around pin on the 4Discovery to control the Transmit/Receive functionality of the RS485 transceiver. This Turn Around Pin control is required as the ViSi-Genie Protocol is defined already and therefore control of the 4Discovery's Transmit/Receive mode needs to be controlled from the Host, the Arduino. ViSi-Genie can be used with other hosts, however, these are the 2 platforms we have libraries written for.

# 11. Connecting to External Hardware

The 4Discovery is capable of acting as both an RS485 Host, and an RS485 Slave when appropriate circuitry is present on the devices being interfaced to, and appropriate software is written. It is also possible to connect multiple 4Discoveries onto a single bus at the same time. Like all Half Duplex RS485 systems though, there can only be 1 Master. All devices on the RS485 bus **MUST** communicate using the same protocol else the system will not work.

## 11.1. Master and Slaves

The 4Discovery is a Half-Duplex RS485 device, which means it operates on a 2-wire RS485 bus and there can be only a single Master device, and multiple Slave devices. Only the Master can initiate communication, and a Slave can only communicate if first spoken to. Only 1 device can talk on the bus at any given time.

The simplest way to achieve this is when building a new network, and each device on the network is programmable and capable of handling a customised protocol. With an appropriate protocol, the Master can initiate communication to one or all slaves at once (a Broadcast), and the Slaves will receive the information, process it and based on which slave the message was intended for, that Slave will reply with the information requested or an Acknowledgement of an Action taken place. In the case of a Broadcast, the Slaves should not attempt to reply at all, as only one device can reply at once and this could lead to chaos on the network (Unless an innovative protocol is derived).

If you are placing a 4Discovery into an existing RS485 system, the 4Discovery must be a Slave device to an existing Master, and an existing Protocol must be programmed into the 4Discovery.

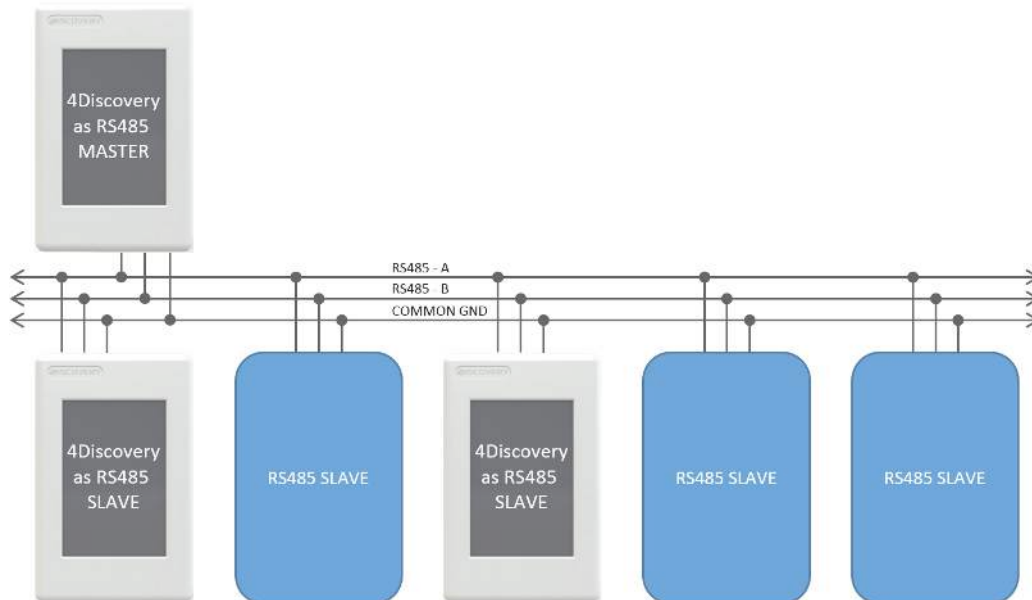

Figure 1: Typical 2-wire RS485 configuration, which includes a common ground

On the 4Discovery, there is a Turn Around pin wired directly to the RS485 transceiver, which switches the system from Transmit to Receive. This pin is also connected to a GPIO of the Diablo16 processor and is capable of being controlled by the 4Discovery to tell other devices the state of the transmit/receive on the 4Discovery.

While many use cases won't utilise the Turn Around pin, it is useful for those special systems where Automatic Direction Control is not possible, such as if an existing protocol does not support it, but the control of a GPIO is possible.

### 11.2. 4Discovery as a Host

The 4Discovery is capable of being the Master device of the RS485 network. Therefore, it needs to communicate with all Slave devices on the network and handle the replies from each of them.

The 4Discovery is fully programmable by the User when used in Designer or ViSi, and therefore every aspect of the system needs to be managed by User Code. To enable the 4Discovery to transmit out of the RS485, the Turn Around pin needs to be High, which is controlled using the PA10 GPIO on the Diablo16 processor on board the 4Discovery. To enable the 4Discovery to receive over RS485, the Turn Around pin needs to be Low.

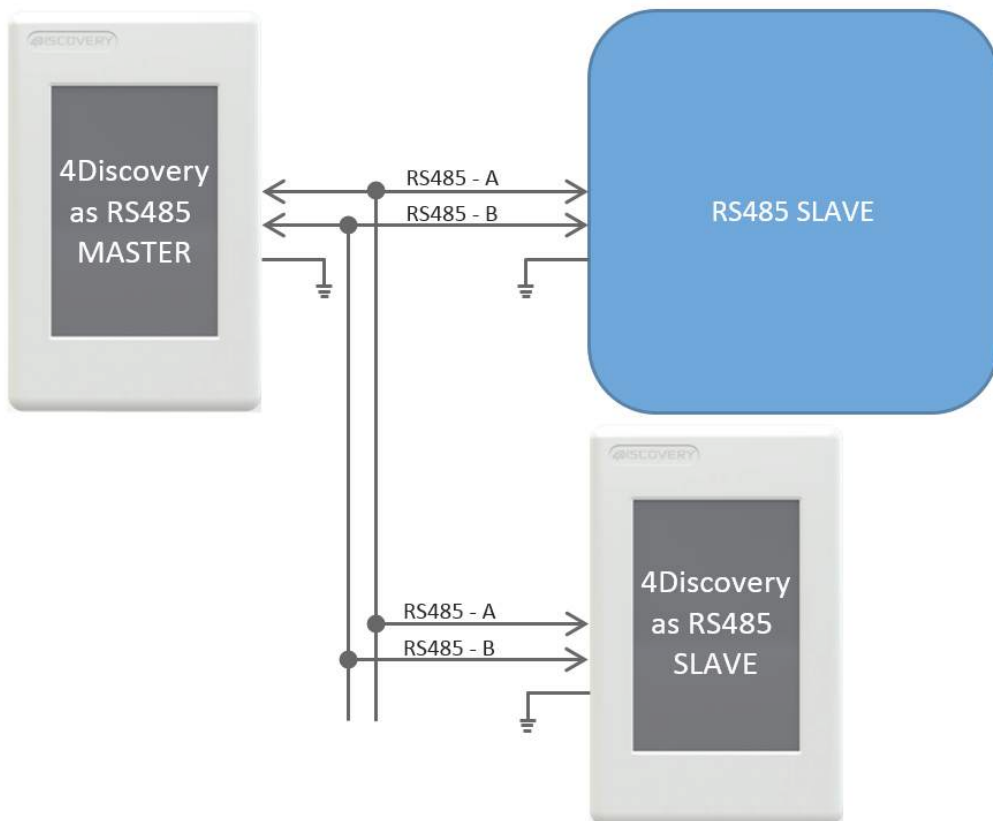

Figure 2: This shows a 4Discovery as the Master of the RS485 Bus, and there are multiple Slaves, which can include multiple 4Discoverys (as Slaves).

As mentioned in **Master and Slaves**, the 4Discovery is capable of being used in new RS485 systems, as well as existing systems. When used in new systems, the 4Discovery protocol can be more easily customised to provide the best mix of features and performance possible, compared to existing systems which typically have a protocol already defined or devices that use a fixed protocol. The 4Discovery is fully programmable so is capable of working with a large range of new and existing systems, even if the protocols are specialised. The main factor is that all devices on the RS485 bus need to take the same protocol, or else the system will not operate correctly.

If there are systems that are not capable of determining when the Slaves are 'allowed' to Transmit, the Turn Around pin may be used from the 4Discovery to indicate when the Master (4Discovery) is transmitting or receiving and may be useful to assist the Slave.

The Master could communicate to each of the Slaves individually, or all of them by doing a Broadcast, however, this is dictated by the User Protocol and how the system is set up.

Each Device on the bus needs to communicate using the same protocol, and each device must be able to control its own Transmit/Receive mode or its RS485 transceiver.

### **11.3. 4Discovery as a Slave**

To operate the 4Discovery as an RS485 Slave, the same considerations need to be made regarding the protocol used in the system, as when the 4Discovery was the Host. An appropriate Protocol is required such that the Master Device transmits out onto the bus to the slaves, either pinpointing a single Slave device, or broadcasting to all Slave devices on the Bus. Based on the Protocol, the Slaves will receive the message and if the message is not intended for them, then discard it. If the message is intended for them then wait for the end of the message and reply accordingly.

The 4Discovery is not capable of Auto Direction Control, and therefore needs to be either externally controlled by the host (as is the case when the 4Discovery is programmed using the 4D RS485 Programmer), or more commonly the 4Discovery would handle the Direction Control of its RS485 transceiver based on the data received on the RS485, dictated by the Protocol.

The PA10 GPIO on the 4Discovery is connected to the Turn Around pin on the RJ45 Jack, and it is also connected to the Transmit/Receive controls of its RS485 transceiver. When the 4Discovery is in Slave Mode, the GPIO needs to be controlled based on the data received over the RS485, to place the 4Discovery in the appropriate Transmit or Receive state based on the information received, dictated by the Users protocol.

If this is not possible, the Turn Around pin can be controlled by the Host to manually change the 4Discovery from being in Transmit or Receive mode, however, this is less desirable and should only be used in special situations. For example, if the 4Discovery is a Slave and the PA10 GPIO is Low, then the Host is currently in Transmit mode, and data could be flowing over the RS485 and should therefore be captured and processed. If the PA10 GPIO is High, then the 4Discovery has the opportunity to reply or send information to the Host if required, in response to the previous data received.

When multiple devices are on the bus, ie more than 1 slave, Designer or ViSi Environments can be used to program the 4Discovery as a Slave. If only a single slave exists and no more are going to be added, ViSi-Genie can be used. Please refer to [ViSi-Genie Limitations with 4Discovery](#) for more information.

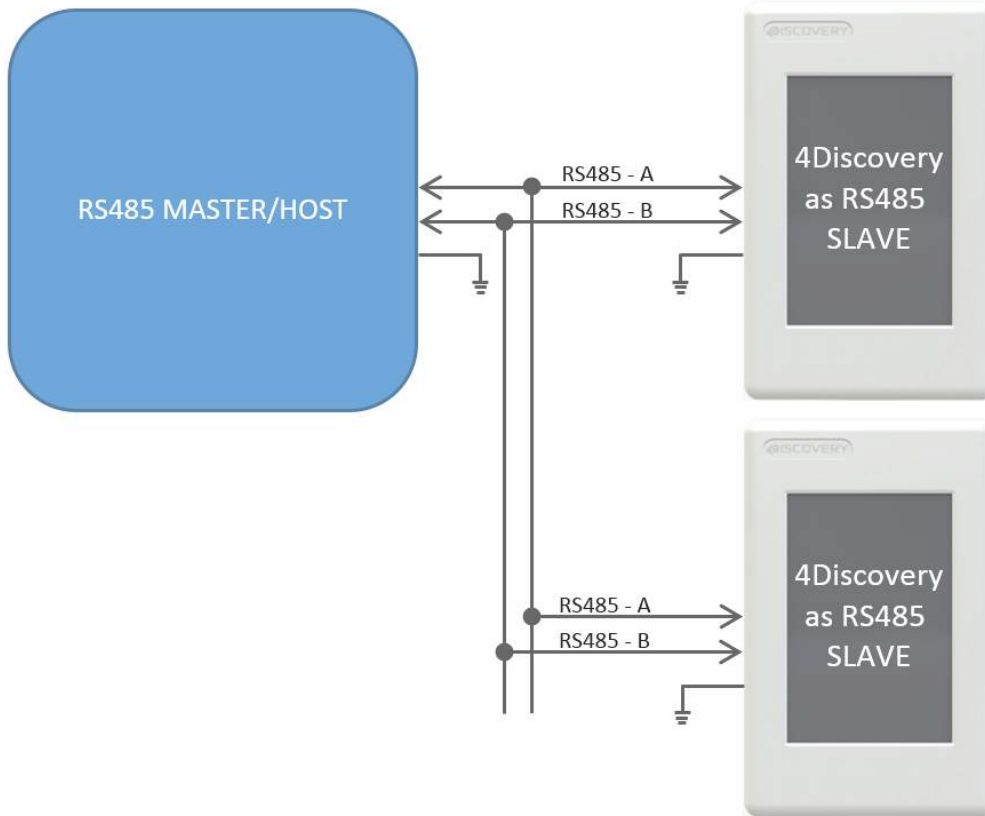

*Figure 3: This shows a situation where there are 1 or more Slaves on the network, of which 1 or more could be a 4Discovery.*

Each Slave needs to handle the changing of its own Transmit/Receive, based on the information received from the Master. Only one Slave should reply at any given time after the Master has transmitted to it. Utilizing RS485 transceivers with Auto Direction control can simplify the setup, however, a suitable protocol needs to be utilized regardless.

### 11.4. 4Discovery Multiple Masters

It is possible to implement a system that has multiple Master devices on the RS485 network, provided the protocol is written to support this.

There may be situations where multiple 4Discoveries are required in a building, all attached to the same RS485 network, and talk to the same Slaves. While this is not a typical situation in the eyes of RS485, it is possible to do if each of the devices on the RS485 can be programmed to handle this. The protocol programmed into the devices needs to be written such that all devices are in Receiving Mode by default, and only go into Transmit Mode when they are initiating a transmission. This will allow any of the 4Discoveries working as Masters to send out a message to the bus, to be received by the other units.

As with any 2-wire RS485 network, only one Master can talk at any given time. If a configuration is used where there are multiple Masters on the same RS485 bus, the programming either needs to prevent multiple Masters from speaking at the same time, or it needs to handle it if the situation arises, such as if 2 Users are working on 4Discoveries in separate locations, and are trying to send onto the bus at the same time.

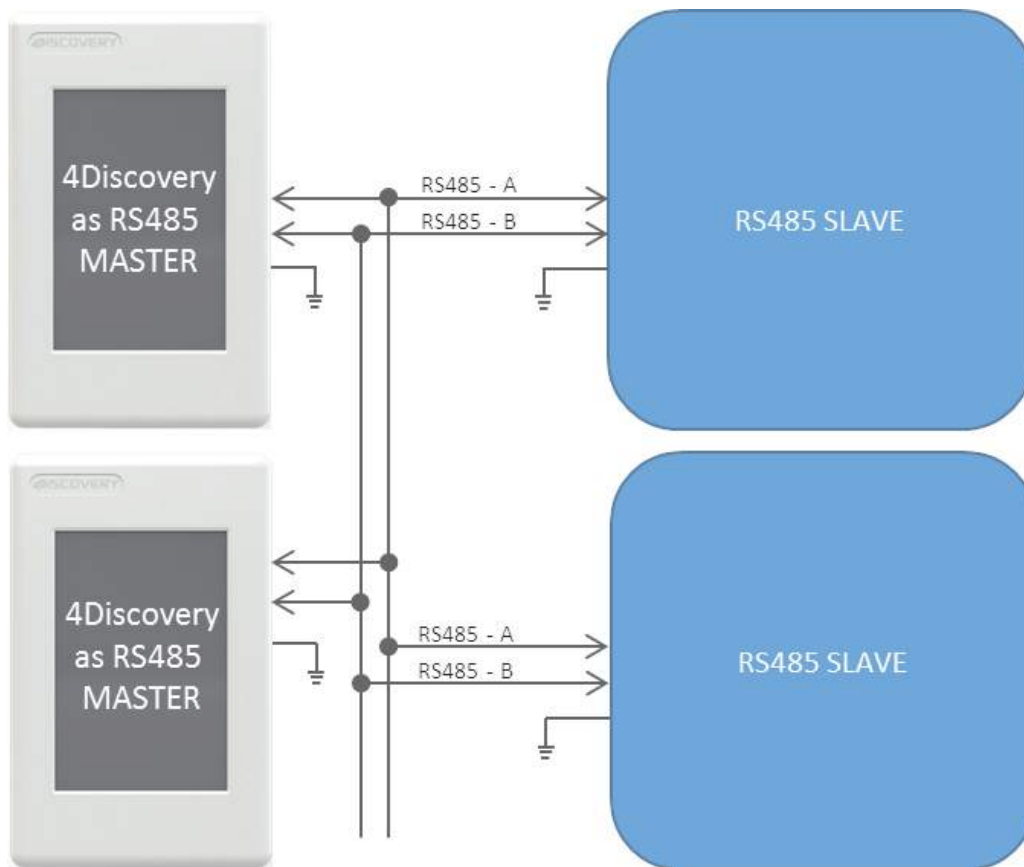

Figure 4: This shows multiple Masters on the RS485 network, with multiple Slaves

A specialised program and protocol are required to realise this setup but is useful if more than 1 4Discovery is required on the network to control the same set of equipment from multiple locations.



## 11.5. Programming 4Discovery

The only method available to program the 4Discovery directly is by using the 4D RS485 Programmer. This device programs the 4Discovery over the RS485 bus, as well as supplying it Power and controlling the Turn Around pin of the 4Discovery and the Reset signal, to appropriately program the on-board Diablo16 Processor.

There is no other programmer which can be used to program the 4Discovery. The 4D RS485 Programmer is also capable of upgrading the PmmC/Firmware of the 4Discovery and the Display Driver, along with the User Application.

An alternative method of loading a new Application on to the 4Discovery is by loading a pre-compiled program from microSD storage, onto the onboard flash of the Diablo16 processor. This can be done using the built-in functions of the Diablo16 processor and enables the 4Discovery to be updated in the field by the End User, without having to have a technician or technical person on call to program the 4Discovery using the 4D RS485 Programmer and PC. This method however cannot be used to upgrade the PmmC or Display Driver. This can only be done using the 4D RS485 Programmer. To enable the loading of precompiled programs onto the 4Discovery from the microSD card, an appropriate application needs to be written, this is not possible straight out of the box.

Here is a diagram to show the basics of how the 4Discovery interfaces with the 4D RS485 Programmer.

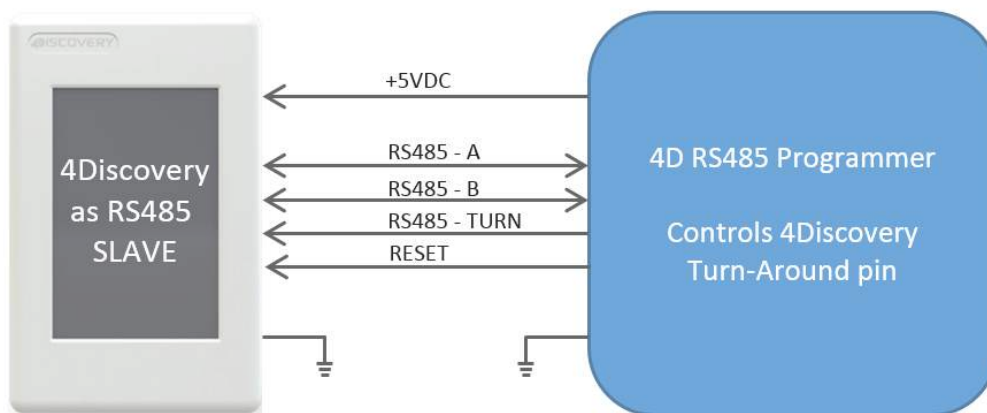

Figure 5: Programming the 4Discovery using the 4D RS485 Programmer.

The Programmer controls the 4Discovery's Turn Around Pin, allowing the programming software to dictate when the 4Discovery is listening and when it is allowed to reply to programming commands. This same setup can be used for general communications also, where there is one external Master and 4Discovery as a single Slave. It is not possible to have multiple Slaves in this situation, due to the way the Turn Around Pin is interfaced with the 4Discovery to make the 4Discovery programmable over the RJ45 connector using RS485.

Programming of the 4Discovery is only possible when the 4Discovery is disconnected from the RS485 network and is connected 1:1 with the 4D 485 Programmer. It is not possible to program it

when connected to the network, as the Reset and Turn Around pins are required to program the 4Discovery, and other devices may try to communicate on the bus when programming is occurring, which could cause corruption and the programming to fail. Reset and Turn pins are also TTL level, so the distance these should ideally be transmitted over, should be as short as possible. Please refer to [4D 485 Programmer](#), for more information.

## 11.6. Termination Resistors

On each 4Discovery is a built-in 120Ω termination resistor. This is open/deactivated by default.

The termination resistor is there to absorb reflections in the RS-485 bus, however typically is only used at each end of the bus, ie the first device and the last device. Depending how you are configuring your system with the 4Discovery, will determine if you need a termination resistor or not. In several cases, having a termination resistor present is better than not having a termination resistor at all, even if the termination is not located at the end of the bus, however, this is very subjective and system dependent.

If the lack of on-board termination is causing problems with communication, it can be enabled but requires the 4Discovery case to be carefully opened and the PCB modified. On the back of the 4Discovery is a cover, which is attached with multiple clips, and can be tricky to remove. Using a plastic tool or possibly two plastic tools, these clips can be carefully opened, and the back cover removed, exposing the circuitry inside.



Under the cover, towards the bottom, are two sets of pads with the label JP1. These two pads need to have a solder blob added to connect them. This will **enable** the 120Ω resistor. If the 120Ω resistor needs to be disabled again, these pads can be unsoldered.

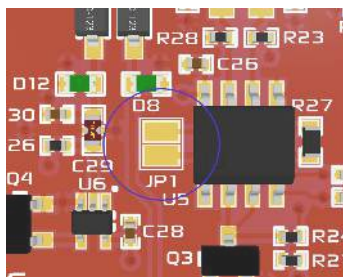

### Note

Extreme care needs to be taken when performing this modification, as too much heat or a slip of the soldering iron could result in components/displays or tracks being damaged. This should only be attempted by people who know the risks and are capable of modifying the PCB.

# 12. Mechanical Details

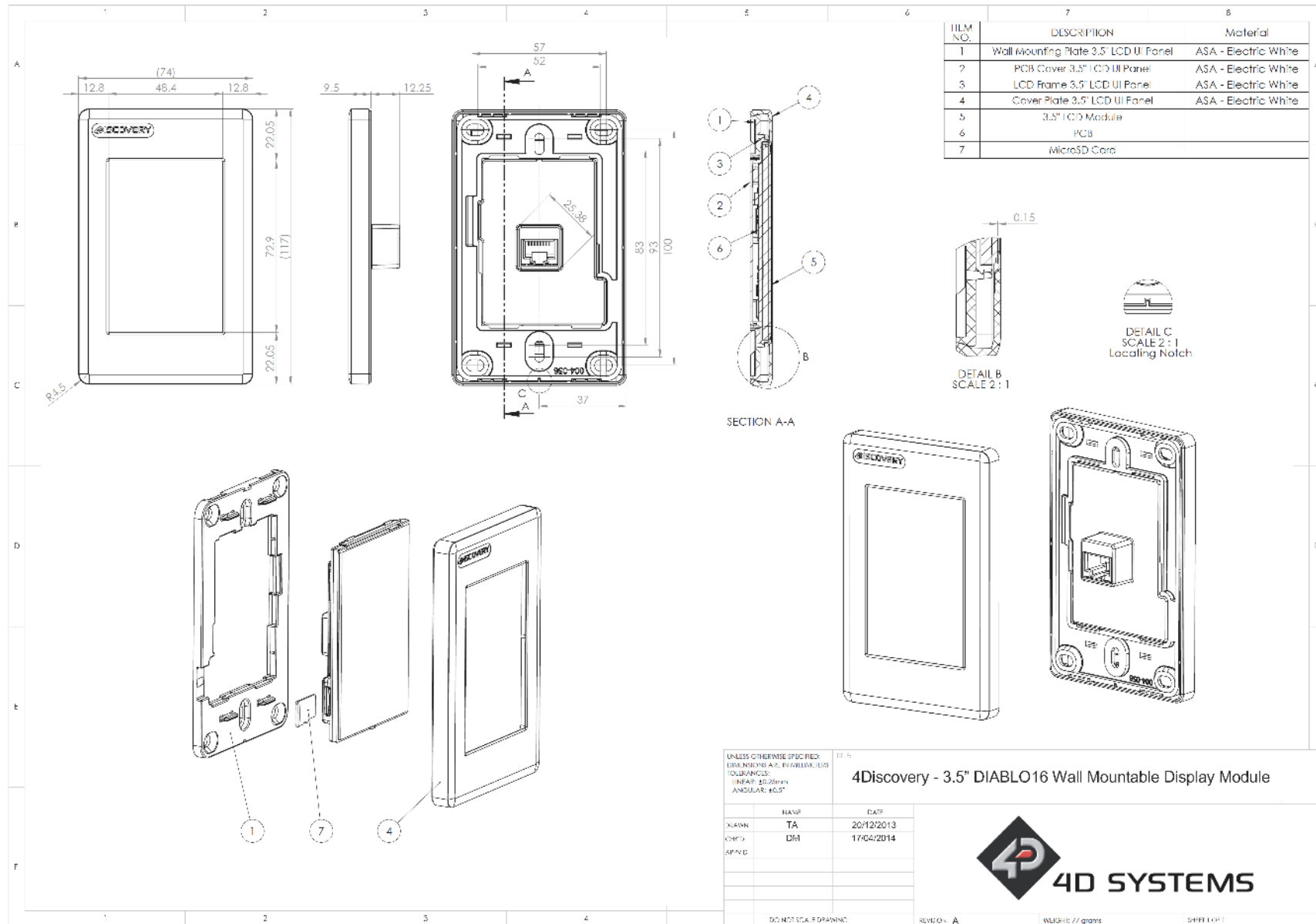

# 13. Schematic Details - HW REV 2.7

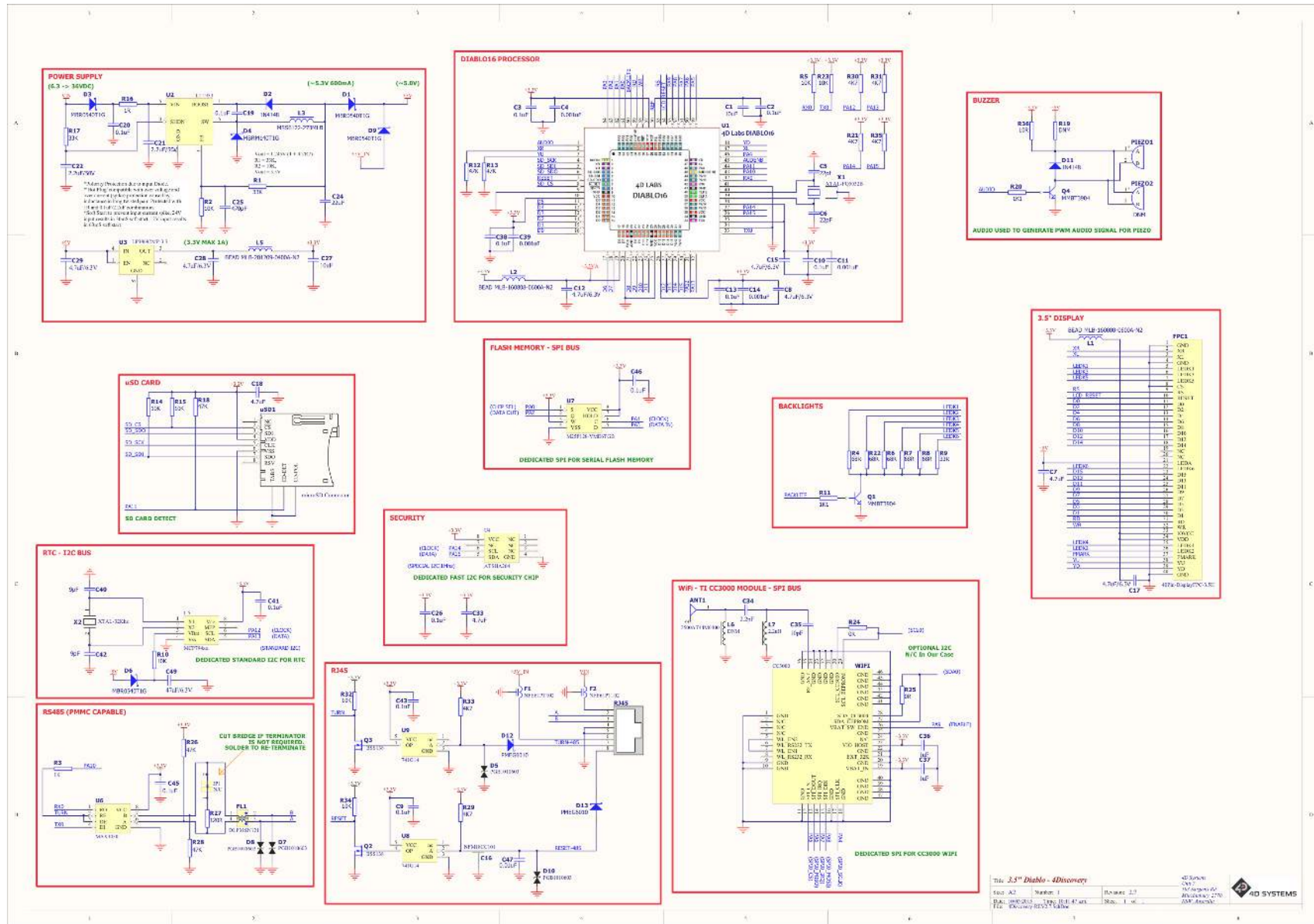

This 3.5" Diab16 - 4Discovery  
 Rev. A2    Number 1    Revision 2.7    4D Systems  
 Date: 2015-03-10    File: HW\_4D\_35    Rev: 1.0    4D Systems

# 14. Schematic Details - HW REV 4.0

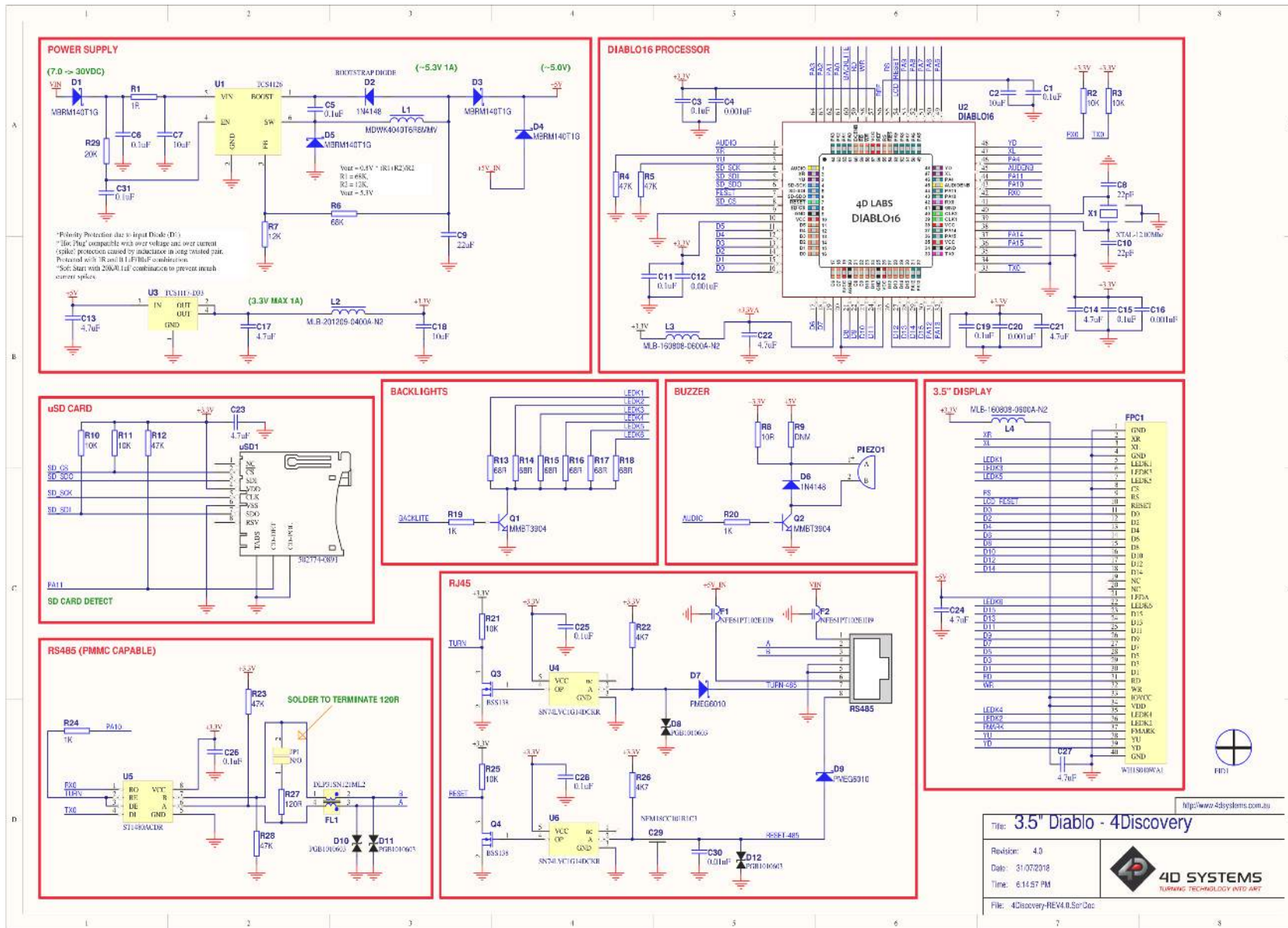



# 15. Schematic Details - HW REV 4.2

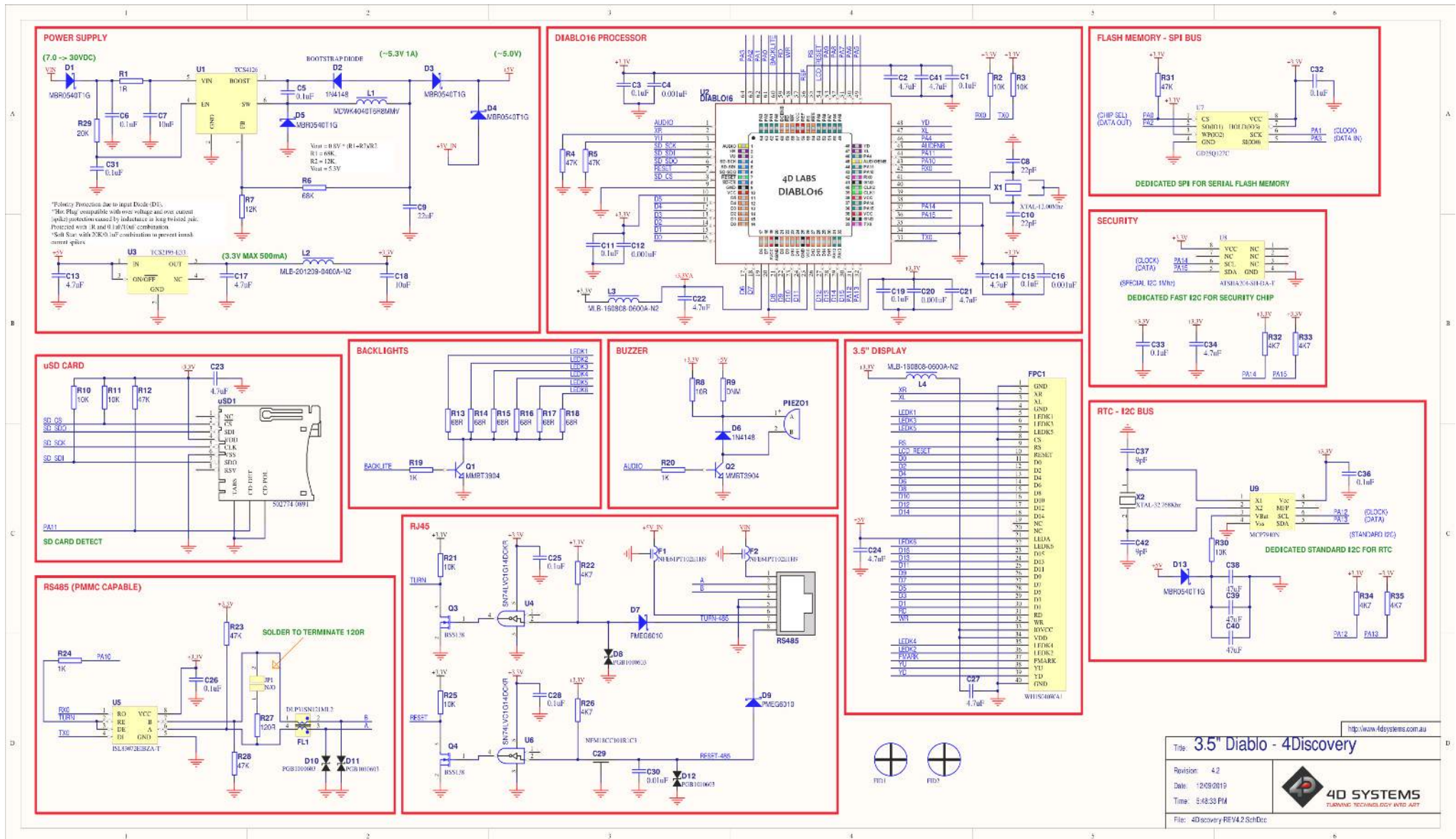

http://www.4dsystems.com.au

Title: 3.5" Diablo - 4Discovery

Revision: 4.2

Date: 12/09/2019

Time: 5:48:30 PM

File: 4Discovery-REV4.2.SchDoc

TURNING TECHNOLOGY INTO ART

## 16. Specifications

### Absolute Maximum Ratings

Operating ambient temperature	-20°C to +70°C
Storage temperature	-30°C to +80°C
Voltage on VCC with respect to GND	7.0V to 30VDC
Voltage on 5V_IN with respect to GND	4.5V to 5.5V

### Note

Stresses above those listed here may cause permanent damage to the device. This is for stress rating only and functional operation of the device at those or any other conditions above those indicated in the recommended operation listings of this specification is not implied. Exposure to maximum rating conditions for extended periods may affect device reliability.

### Recommended Operating Conditions

Parameter	Conditions	Min	Typ	Max	Units
Supply Voltage (VCC)	Stable external supply required	7.0	12.0	30.0	V
Supply Voltage(5V_IN)	Stable external supply required	4.5	5.0	5.5	V
Operating Temperature		-10	--	+60	°C
Reset Pulse	External Open Collector	20	--	--	µs
Operational Delay	Power-Up or External Reset	500	--	5000	ms

Global Characteristics Based on Operating Conditions					
Parameter	Conditions	Min	Typ	Max	Units
Supply Current (ICC)	12V, heavily depends on screen usage conditions, SD Card etc (REV 4.0)	11	120	--	mA
	5V, heavily depends on screen usage conditions, SD Card etc (REV 4.0)	23	200	--	mA
Diablo16 Flash Memory Endurance	Pmmc / Application Programming	--	1 0000	--	E/W
Diablo16 Memory Data Retention	Provided Maximum ratings are not exceeded	20	--	--	Years
Display Endurance	Hours of operation, measured to when the display is 50% original brightness	--	20000	--	H

## 17. Revision History

Hardware Revision		
Revision Number	Date	Description
2.7	01/03/2015	Limited Public Release
4.0	01/07/2018	<ul style="list-style-type: none"> <li>- Removal of CC3000 WiFi Module due to EOL</li> <li>- Removal of Crypto Authentication IC</li> <li>- Changing of some components from 0603 to 0402</li> <li>- Removal of RTC and Flash IC</li> </ul>
4.2	29/05/2019	<ul style="list-style-type: none"> <li>- Addition of optional Crypto Authentication IC</li> <li>- Addition of optional RTC</li> <li>- Addition of optional Flash IC</li> </ul>

Datasheet Revision		
Revision Number	Date	Description
2.0	09/12/2015	Initial Public Release Version
2.1	28/03/2019	Cosmetic Changes and Formatting
2.2	09/12/2015	Added discussions for Crypto Authentication IC, RTC and Flash IC
2.3	17/08/2020	Fixed some mistakes and Formatting
2.4	14/12/2022	Modified datasheet for web-based documentation