

DESCRIPTION

The SY100S341 offer eight D-type, edge-triggered flip-flops with both individual inputs for parallel operation as well as serial inputs for bidirectional shifting, and are designed for use in high-performance ECL systems. Data is clocked into the flip-flops on the rising edge of the clock.

The mode of operation is selected by two Select inputs (S0, S1) which determine if the device performs a shift, hold or parallel entry function, as described in the Truth Table. The inputs on these devices have 75KΩ pull-down resistors.

PIN CONFIGURATIONS

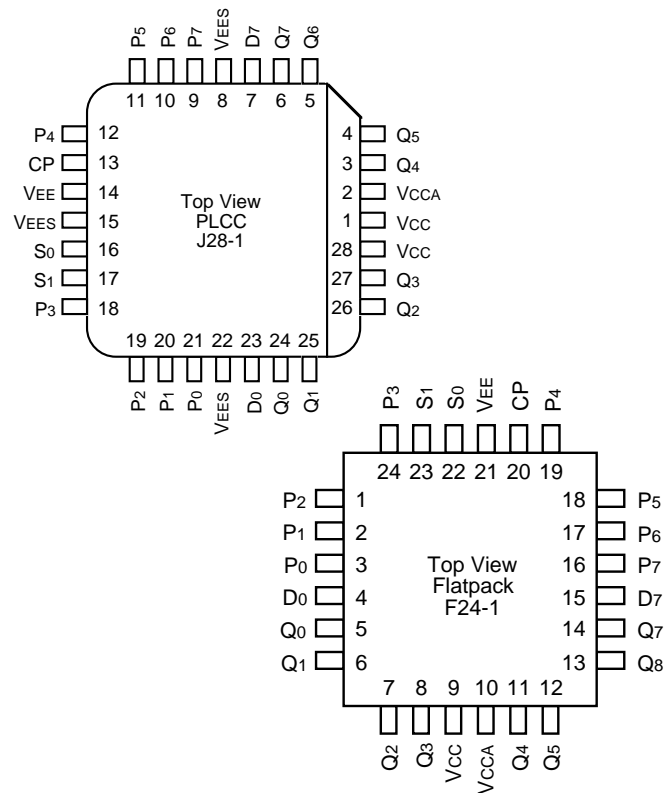

PIN NAMES

Label	Function
CP	Clock Pulse Input
S0 — S1	Select Inputs
D0 — D7	Serial Inputs
P0 — P7	Parallel Inputs
Q0 — Q7	Data Outputs
VEES	VEE Substrate
VCCA	Vcco for ECL Outputs

- Max. shift frequency of 600MHz
- Max. Clock to Q delay of 1200ps
- IEE min. of -150mA
- Industry standard 100K ECL levels
- Extended supply voltage option:
VEE = -4.2V to -5.5V
- Voltage and temperature compensation for improved noise immunity
- Internal 75KΩ input pull-down resistors
- 70% faster than Fairchild 300K at lower power
- Function and pinout compatible with Fairchild F100K
- Available in 24-pin CERPACK and 28-pin PLCC packages

BLOCK DIAGRAM

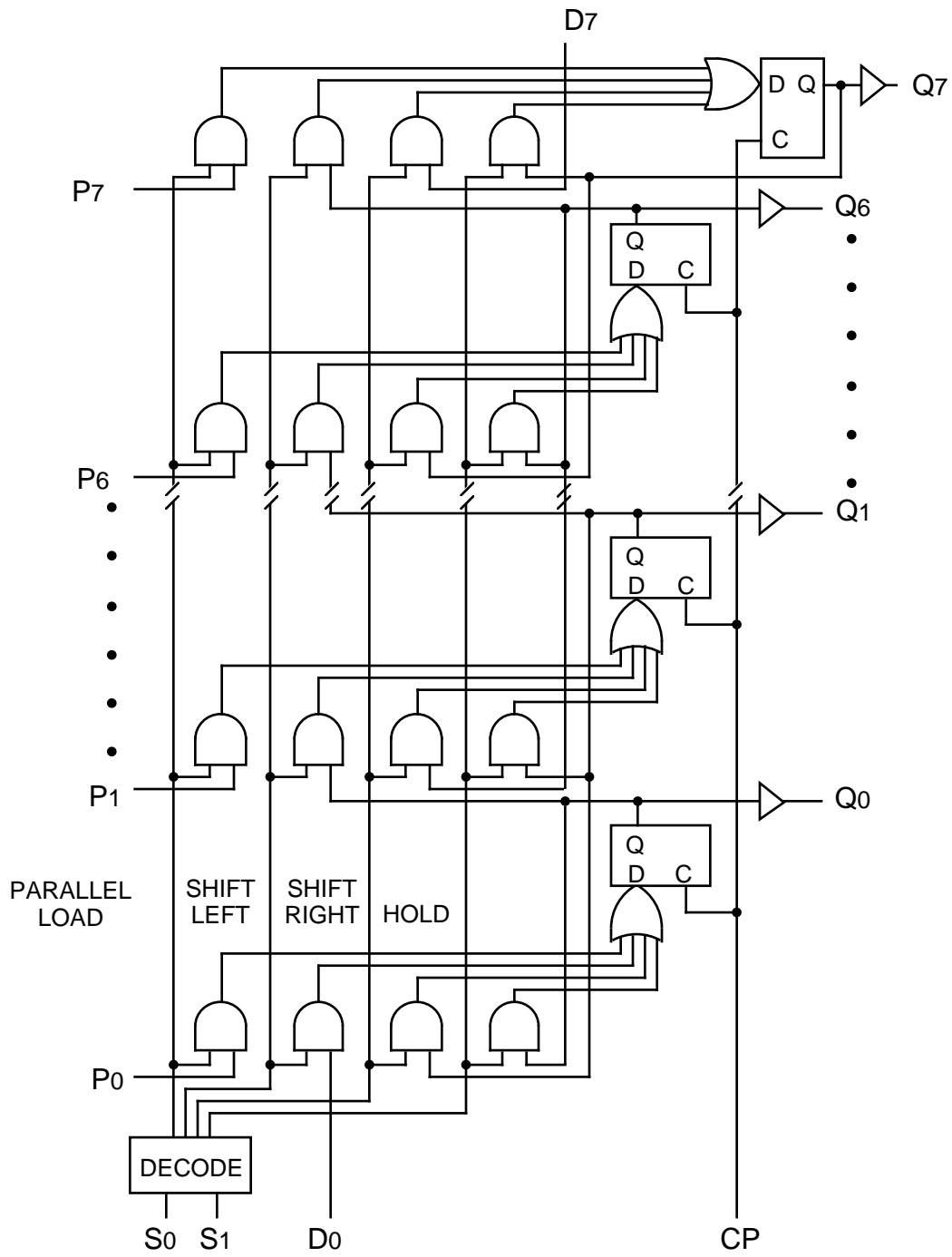

TRUTH TABLE

Function	Inputs					Outputs							
	D7	D0	S1	S0	CP	Q7	Q6	Q5	Q4	Q3	Q2	Q1	Q0
Load Register	X	X	L	L	u	P7	P6	P5	P4	P3	P2	P1	P0
Shift Left	X	L	L	H	u	Q6	Q5	Q4	Q3	Q2	Q1	Q0	L
Shift Left	X	H	L	H	u	Q6	Q5	Q4	Q3	Q2	Q1	Q0	H
Shift Right	L	X	H	L	u	L	Q7	Q6	Q5	Q4	Q3	Q2	Q1
Shift Right	H	X	H	L	u	H	Q7	Q6	Q5	Q4	Q3	Q2	Q1
Hold	X	X	H	H	X	No Change							
Hold	X	X	X	X	H	No Change							
Hold	X	X	X	X	L	No Change							

NOTE:

- 1. H = HIGH Voltage Level
- L = LOW Voltage Level
- X = Don't Care
- u = LOW-to-HIGH Transition

DC ELECTRICAL CHARACTERISTICS

V_{EE} = -4.2V to -5.5V unless otherwise specified; V_{CC} = V_{CCA} = GND

Symbol	Parameter	Min.	Typ.	Max.	Unit	Condition
I _{IH}	Input HIGH Current, All Inputs	—	—	200	μA	V _{IN} = V _{IH} (Max.)
I _{EE}	Power Supply Current	-150	-102	-71	mA	Inputs Open

AC ELECTRICAL CHARACTERISTICS

CERPACK

V_{EE} = -4.2V to -5.5V unless otherwise specified; V_{CC} = V_{CCA} = GND

Symbol	Parameter	TA = 0°C		TA = +25°C		TA = +85°C		Unit	Condition
		Min.	Max.	Min.	Max.	Min.	Max.		
f _{shift}	Shift Frequency	600	—	600	—	600	—	MHz	
t _{PLH} t _{PHL}	Propagation Delay CP to Output	450	1200	450	1200	450	1200	ps	
t _{TLH} t _{THL}	Transition Time 20% to 80%, 80% to 20%	300	900	300	900	300	900	ps	
t _s	Set-up Time D _n , P _n S _n	300 600	— —	300 600	— —	300 600	— —	ps	
t _H	Hold Time D _n , P _n S _n	300 0	— —	300 0	— —	300 0	— —	ps	
t _{pw} (H)	Pulse Width HIGH, CP	—	600	—	600	—	600	ps	

AC ELECTRICAL CHARACTERISTICS

PLCC

VEE = -4.2V to -5.5V unless otherwise specified; VCC = VCCA = GND

Symbol	Parameter	TA = 0°C		TA = +25°C		TA = +85°C		Unit	Condition
		Min.	Max.	Min.	Max.	Min.	Max.		
fshift	Shift Frequency	600	—	600	—	600	—	MHz	
tPLH tPHL	Propagation Delay CP to Output	450	1200	450	1200	450	1200	ps	
tTLH tTHL	Transition Time 20% to 80%, 80% to 20%	300	900	300	900	300	900	ps	
ts	Set-up Time								
	Dn, Pn	300	—	300	—	300	—	ps	
	Sn	600	—	600	—	600	—		
th	Hold Time								
	Dn, Pn	300	—	300	—	300	—	ps	
	Sn	0	—	0	—	0	—		
tpw (H)	Pulse Width HIGH, CP	—	600	—	600	—	600	ps	

TIMING DIAGRAMS

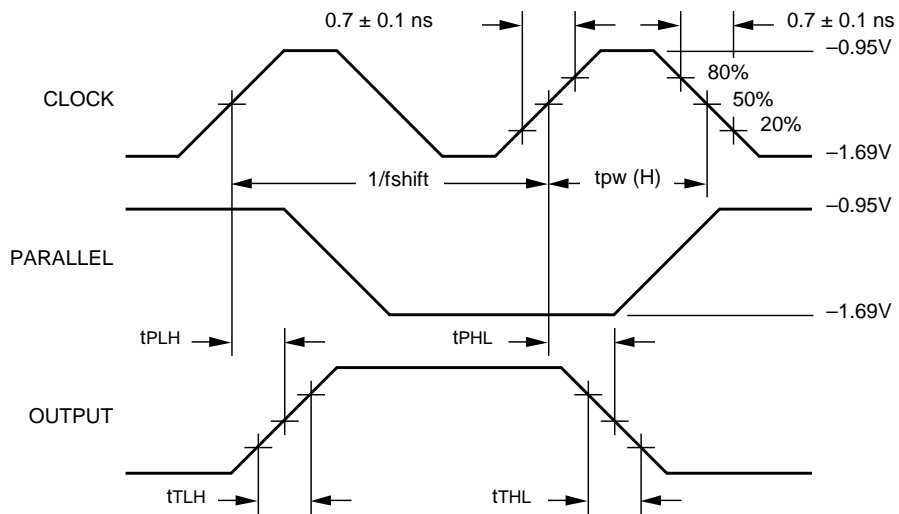

Propagation Delay and Transition Times

TIMING DIAGRAMS

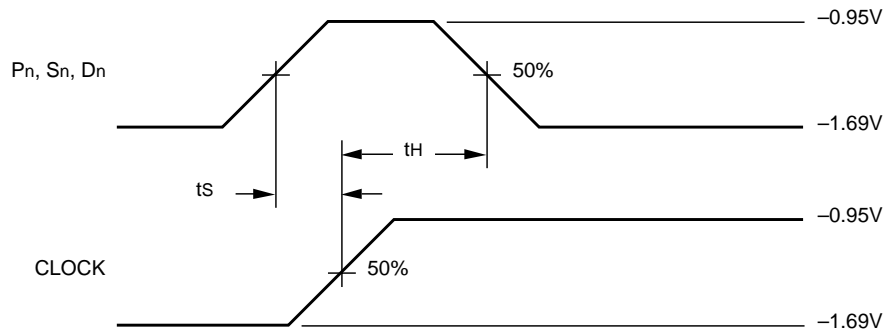

Set-up and Hold Times

NOTES:

1. $V_{EE} = -4.2V$ to $-5.5V$ unless otherwise specified; $V_{CC} = V_{CCA} = GND$.
2. t_s is the minimum time before the transition of the clock that information must be present at the data input.
3. t_H is the minimum time after the transition of the clock that information must remain unchanged at the data input.

PRODUCT ORDERING CODE

Ordering Code	Package Type	Operating Range
SY100S341FC	F24-1	Commercial
SY100S341JC	J28-1	Commercial
SY100S341JCTR	J28-1	Commercial

24 LEAD CERPACK (F24-1)

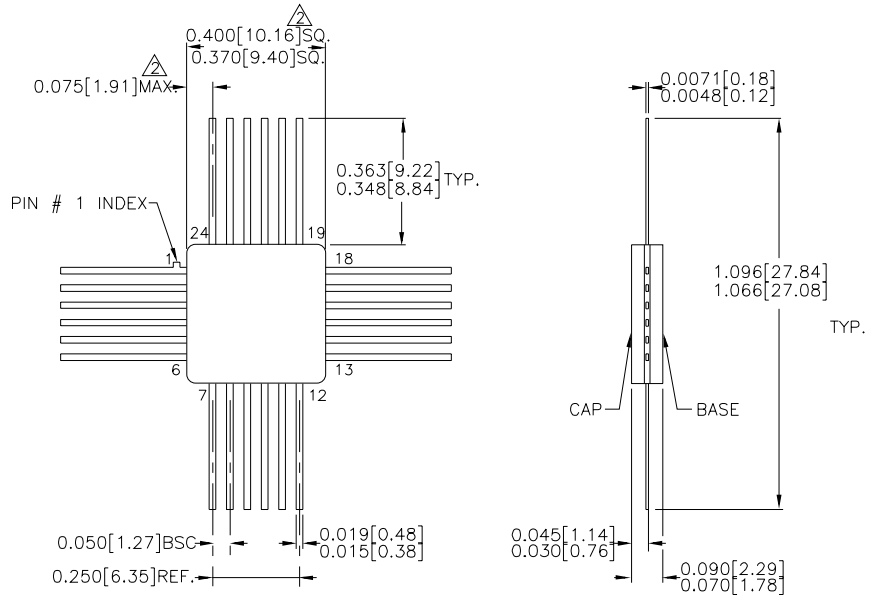

- NOTES:
1. DIMENSIONS ARE IN INCHES[MM].
 2. THIS DIMENSION INCLUDES GLASS PROTRUSION AND CAP TO BASE ALIGNMENT TOLERANCES.
 3. DIMENSIONS SHOWN ARE MAX/MIN, WHERE NOTED.

Rev. 03

28 LEAD PLCC (J28-1)

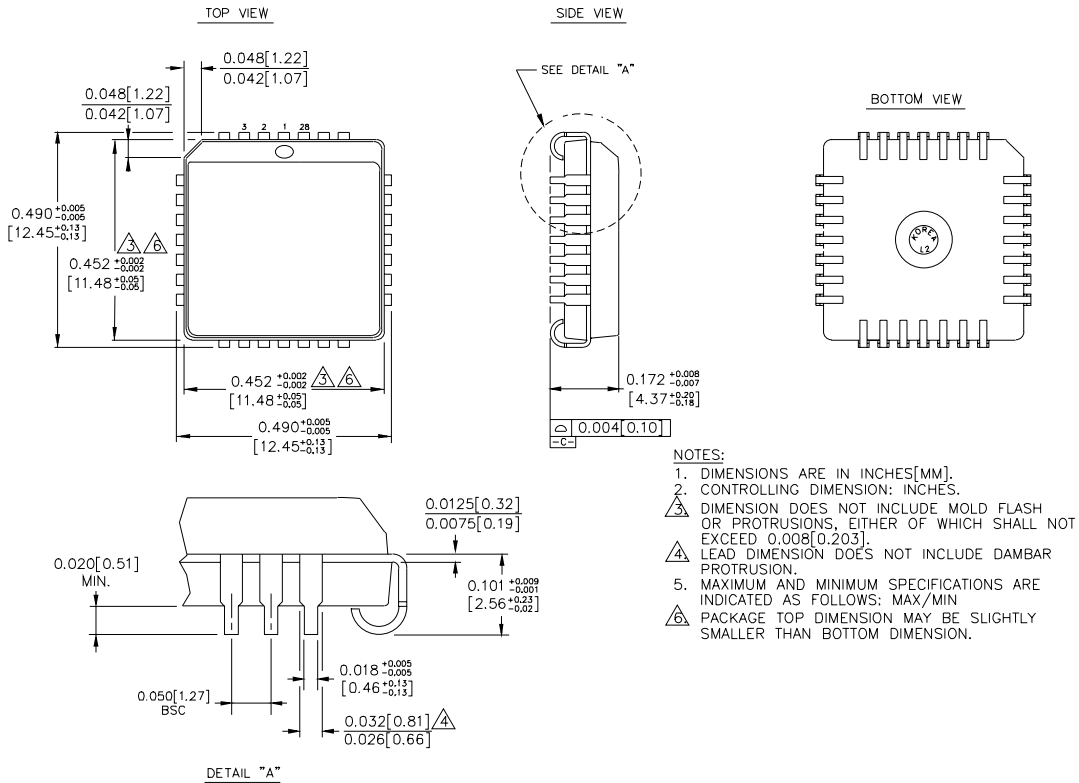

Rev. 03

MICREL-SYNERGY 3250 SCOTT BOULEVARD SANTA CLARA CA 95054 USA

TEL + 1 (408) 980-9191 FAX + 1 (408) 914-7878 WEB <http://www.micrel.com>

This information is believed to be accurate and reliable, however no responsibility is assumed by Micrel for its use nor for any infringement of patents or other rights of third parties resulting from its use. No license is granted by implication or otherwise under any patent or patent right of Micrel Inc.

© 2000 Micrel Incorporated