

DO NOT SCALE FROM THIS PRINT

DESIGNED & DIMENSIONED IN INCHES[MILLIMETERS]

PRF92-P-C-EE-086D-SD

SERIES
-92: 2.92mm

GENDER
-P: PLUG

TYPE
-C: CABLE

FINISH
-EE: 50µ" EXTRA HEAVY GOLD CENTER CONTACT, 50µ" EXTRA HEAVY GOLD OUTER CONTACT

TERMINATION
D: DIRECT SOLDER

ORIENTATION
-S: STRAIGHT

CABLE TYPE
-086D: EZ-86-LA SEMI-RIGID

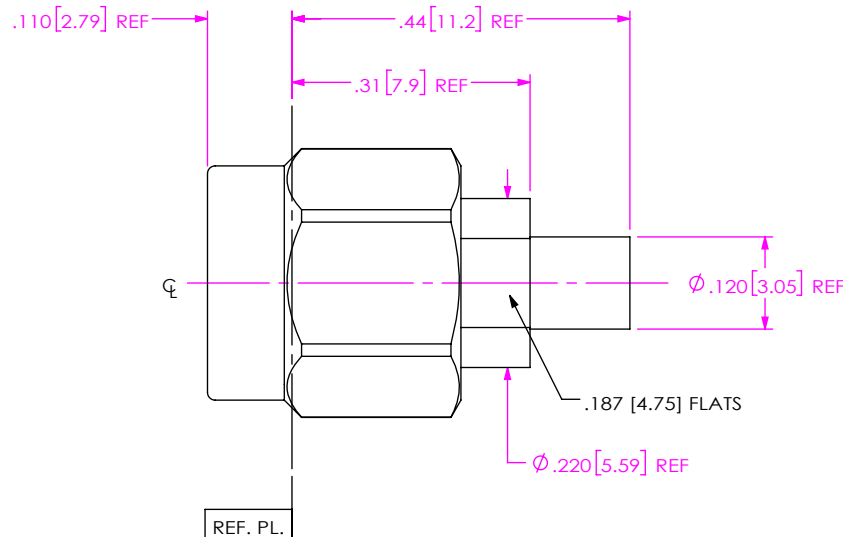
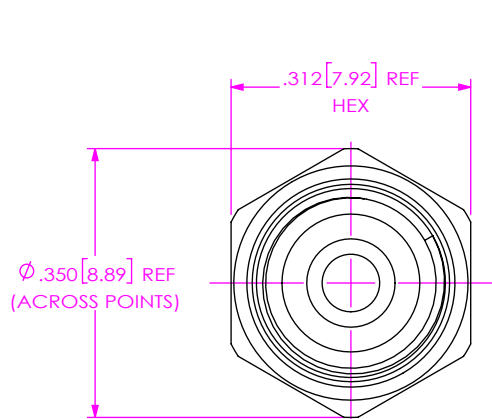

NOTES:

- MATERIAL:**
COUPLING NUT & BUSHING: STAINLESS STEEL.
BODY & CONTACT, LOCK RING: BERYLLIUM COPPER.
BEAD: ULTEM 1000.
GASKET: SILICONE RUBBER.
- FINISH:**
COUPLING NUT & BUSHING: PASSIVATED.
BODY & CONTACT: GOLD OVER NICKEL PLATE,
50 MIN GOLD OVER 50 MIN NICKEL.
- PCI P/N: 4134.

F:\DWG\MISC\MKTG\PRF92-P-C-EE-086D-SD-MKT.SLDDRW

UNLESS OTHERWISE SPECIFIED, DIMENSIONS ARE IN INCHES. TOLERANCES ARE: DECIMALS ANGLES .XX: $\pm .02 [0.5]$ 1° .XXX: $\pm .005 [0.13]$.XXXX: $\pm .0005 [0.013]$	PROPRIETARY NOTE * THIS DOCUMENT CONTAINS CONFIDENTIAL AND PROPRIETARY INFORMATION AND ALL DESIGN, MANUFACTURING, REPRODUCTION, USE, PATENT RIGHTS AND SALES RIGHTS ARE EXPRESSLY RESERVED BY SAMTEC, INC. THIS DOCUMENT SHALL NOT BE DISCLOSED, IN WHOLE OR PART, TO ANY UNAUTHORIZED PERSON OR ENTITY NOR REPRODUCED, TRANSFERRED OR INCORPORATED IN ANY OTHER PROJECT IN ANY MANNER WITHOUT THE EXPRESS WRITTEN CONSENT OF SAMTEC, INC.	 520 PARK EAST BLVD, NEW ALBANY, IN 47150 PHONE: 812-944-6733 FAX: 812-948-5047 e-Mail: info@SAMTEC.com code 55322

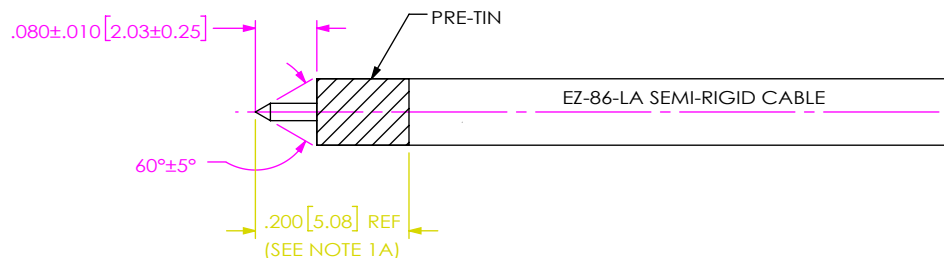

- 1A. PRE-TIN CABLE OUTER JACKET OVER APPROX. LENGTH SHOWN.
- 1B. TRIM CABLE TO EXPOSE CENTER CONDUCTOR AS SHOWN.
- 1C. POINT CENTER CONDUCTOR AS INDICATED.

IN-PROCESS 1

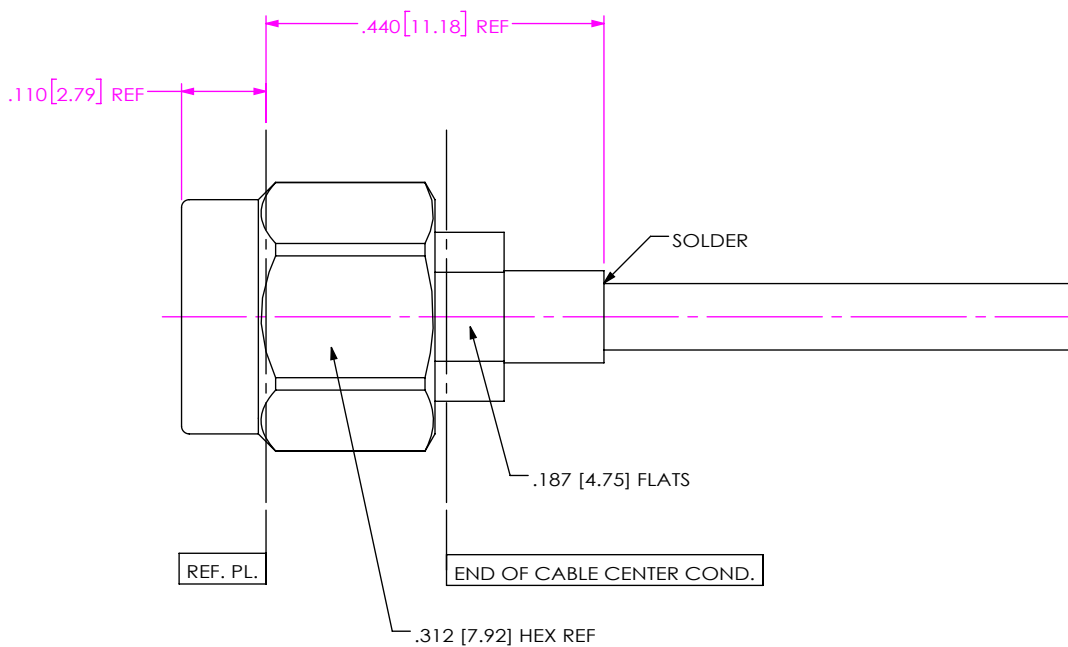

- 2A. INSERT CABLE INTO CONNECTOR UNTIL CENTER CONDUCTOR PLUGS IN AND CABLE SEATS IN CONNECTOR BORE.
- 2B. SOLDER CABLE JACKET TO BODY WHERE SHOWN APPLYING HEAT TO EXTENDED BODY TAIL.

IN-PROCESS 2

PROPRIETARY NOTE
 THIS DOCUMENT CONTAINS CONFIDENTIAL AND PROPRIETARY INFORMATION AND ALL DESIGN, MANUFACTURING, REPRODUCTION, USE, PATENT RIGHTS AND SALES RIGHTS ARE EXPRESSLY RESERVED BY SAMTEC, INC. THIS DOCUMENT SHALL NOT BE DISCLOSED, IN WHOLE OR PART, TO ANY UNAUTHORIZED PERSON OR ENTITY NOR REPRODUCED, TRANSFERRED OR INCORPORATED IN ANY OTHER PROJECT IN ANY MANNER WITHOUT THE EXPRESS WRITTEN CONSENT OF SAMTEC, INC.

samtec
 520 PARK EAST BLVD, NEW ALBANY, IN 47150
 PHONE: 812-944-6733 FAX: 812-948-5047
 e-Mail: info@SAMTEC.com code 55322

DO NOT SCALE DRAWING
 SHEET SCALE: 4:1

DESCRIPTION: 2.92MM PLUG, DIRECT SOLDER FOR EZ-86-LA SEMI-RIGID CABLE
 DWG. NO. PRF92-P-C-EE-086D-SD
 BY: EVE L 12/04/2020 SHEET 2 OF 2