

THIS DRAWING IS UNPUBLISHED. RELEASED FOR PUBLICATION .19
 © COPYRIGHT 19 BY AMP INCORPORATED. ALL RIGHTS RESERVED.

LOC	DIST	REVISIONS			
P	LTR	DESCRIPTION	DATE	DWN	APVD
	C	REV & REDRAWN; 0600-7141-98	1-99	CT	DE
	D	REV PER 0600-8403-99	1-00	JEB	DE

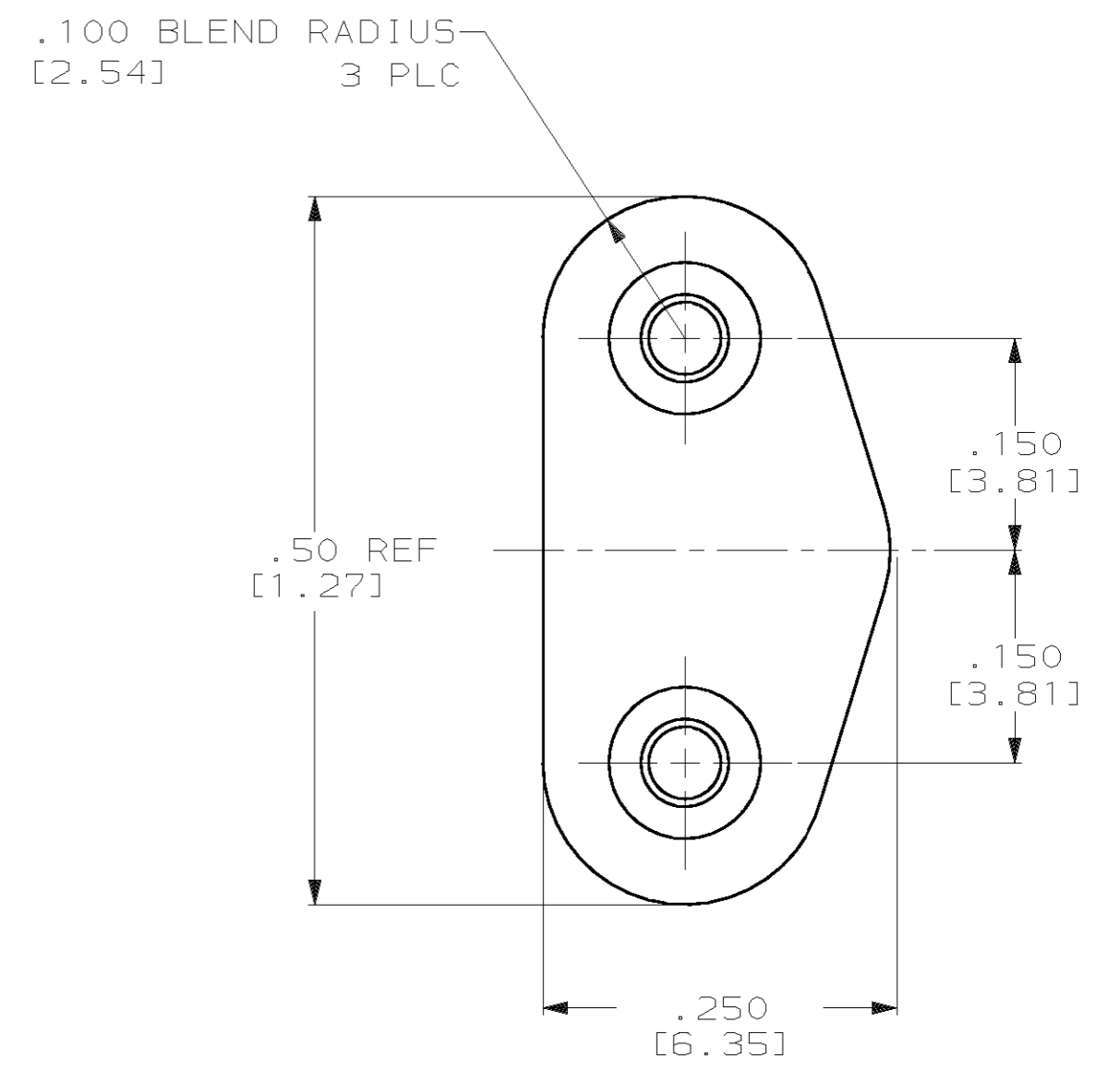
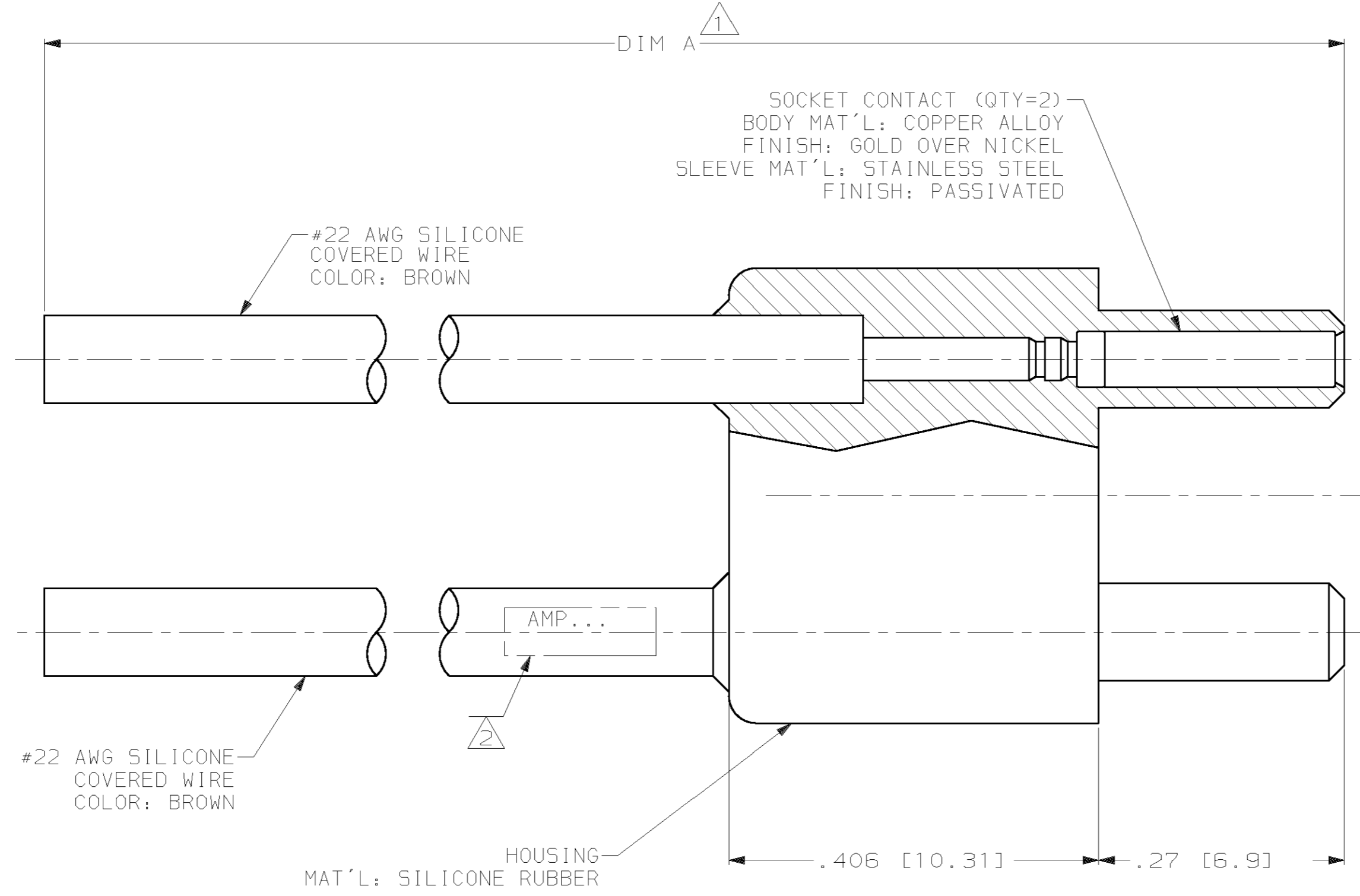

¹ TOLERANCE: UP TO 24.00 [609.6] ±.12 [3.0]
24.00 [609.6] AND UP ±1%

² AMP INFO MARKED PER MIL-STD-130.

	16.00 [406.4]	866559-5
	48.00 [1219.2]	866559-4
	24.00 [609.6]	866559-3
OBSOLETE	18.00 [457.2]	866559-2
	12.00 [304.8]	866559-1
	A DIM	PART NO.

THIS DRAWING IS A CONTROLLED DOCUMENT.		DWN C.C. THOMAS 1/26/99	AMP Incorporated Harrisburg, PA 17105-3608	
DIMENSIONS: INCHES [mm]		CHK D.EABY 1/26/99	NAME D.EABY	
TOLERANCES UNLESS OTHERWISE SPECIFIED:		APVD D.EABY 1/26/99	PRODUCT SPEC	
0 PLC ±-		APPLICATION SPEC		
1 PLC ±-		WEIGHT		
2 PLC ±.02 [0.5]		SCALE 8:1		
3 PLC ±.005 [0.13]		SHEET 1 OF 1		
4 PLC ±-		REV D		
ANGLES ±-		CUSTOMER DRAWING		
FINISH -		SIZE A2		
		CAGE CODE 00779		
		DRAWING NO. C-866559		
		RESTRICTED TO -		