



CMOS High-Speed 8-Bit ADCs with Multiplexer and Reference

MAX154/MAX158

General Description

The MAX154/MAX158 are high-speed multi-channel analog-to-digital converters (ADCs). The MAX154 has four analog input channels while the MAX158 has eight channels. Conversion time for both devices is 2.5µs. The MAX154/MAX158 also feature a 2.5V on-chip reference, forming a complete high-speed data acquisition system.

Both converters include a built-in track/hold, eliminating the need for an external track/hold. The analog input range is 0V to +5V, although the ADC operates from a single +5V supply.

Microprocessor interfaces are simplified by the ADC's ability to appear as a memory location or I/O port without the need for external logic. The data outputs use latched, three-state buffer circuitry to allow direct connection to a microprocessor data bus or system input port.

Applications

- Digital Signal Processing
- High-Speed Data Acquisition
- Telecommunications
- High-Speed Servo Control
- Audio Instrumentation

Features

- ◆ One-Chip Data Acquisition System
- ◆ Four or Eight Analog Input Channels
- ◆ 2.5µs per Channel Conversion Time
- ◆ Internal 2.5V Reference
- ◆ Built-In Track/Hold Function
- ◆ 1/2LSB Error Specification
- ◆ Single +5V Supply Operation
- ◆ No External Clock
- ◆ New Space-Saving SSOP Package

Ordering Information

PART	TEMP. RANGE	PIN-PACKAGE	ERROR (LSB)
MAX154ACNG	0°C to +70°C	24 Narrow Plastic DIP	±1/2
MAX154BCNG	0°C to +70°C	24 Narrow Plastic DIP	±1
MAX154BC/D	0°C to +70°C	Dice	±1/2
MAX154ACWG	0°C to +70°C	24 Wide SO	±1/2
MAX154BCWG	0°C to +70°C	24 Wide SO	±1
MAX154ACAG	0°C to +70°C	24 SSOP	±1/2
MAX154BCAG	0°C to +70°C	24 SSOP	±1

Ordering Information continued at end of data sheet.

Pin Configurations

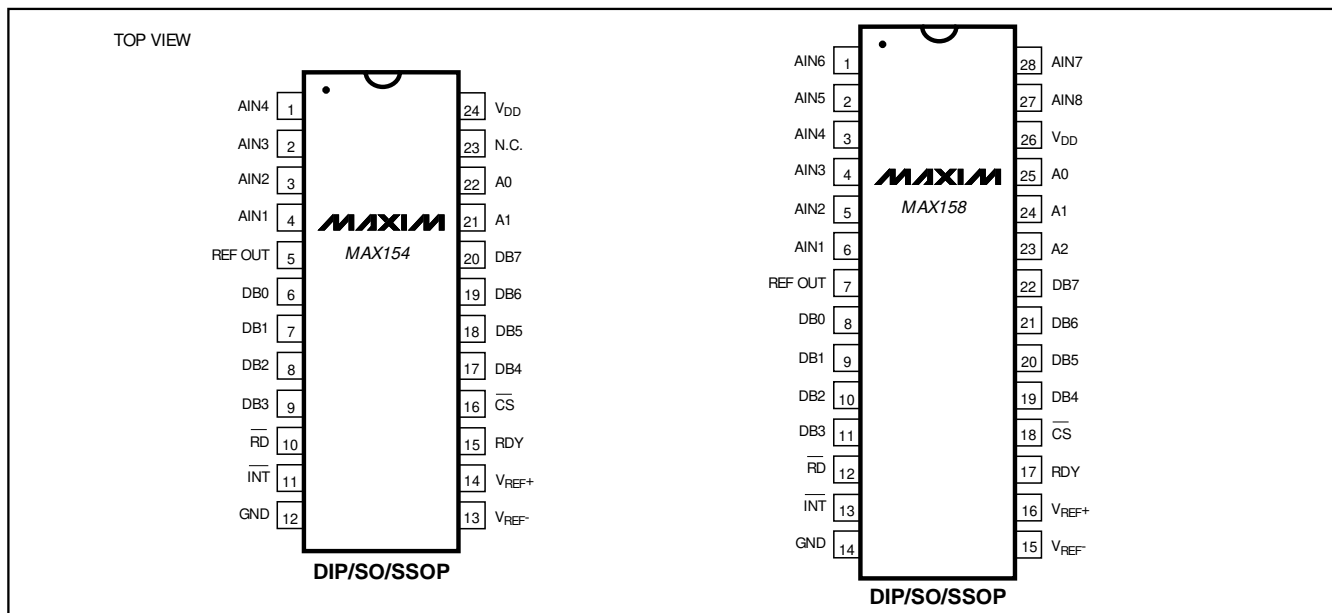

CMOS High-Speed 8-Bit ADCs with Multiplexer and Reference

ABSOLUTE MAXIMUM RATINGS

Supply Voltage, V_{DD} to GND.....0V, +10V
 Voltage at Any Other Pins.....GND -0.3V, V_{DD} +0.3V
 Output Current (REF OUT).....30mA
 Power Dissipation (any package) to +75°C450mW
 Derate above +25°C by6mW/°C

Operating Temperature Ranges

MAX15__C_.....0°C to +70°C
 MAX15__E_.....-40°C to +85°C
 MAX15__M_.....-55°C to +125°C
 Storage Temperature Range-65°C to +160°C
 Lead Temperature (soldering, 10sec)+300°C

Stresses beyond those listed under "Absolute Maximum Ratings" may cause permanent damage to the device. These are stress ratings only, and functional operation of the device at these or any other conditions beyond those indicated in the operational sections of the specifications is not implied. Exposure to absolute maximum rating conditions for extended periods may affect device reliability.

ELECTRICAL CHARACTERISTICS

(V_{DD} = +5V, V_{REF+} = +5V, V_{REF-} = GND, Mode 0, T_A = T_{MIN} to T_{MAX} , unless otherwise noted).

PARAMETER	SYMBOL	CONDITIONS	MIN	TYP	MAX	UNITS
ACCURACY						
Resolution			8			Bits
Total Unadjusted Error (Note 1)		MAX15__A_			±1/2	LSB
		MAX15__B_			±1	
No-Missing-Codes Resolution			8			Bits
Channel-to-Channel Mismatch					±1/4	LSB
REFERENCE INPUT						
Reference Resistance			1		4	kΩ
V_{REF+} Input Voltage Range			V_{REF-}		V_{DD}	V
V_{REF-} Input Voltage Range			GND		V_{REF+}	V
REFERENCE OUTPUT (Note 2)						
Output Voltage	REF OUT	T_A = +25°C	2.47	2.50	2.53	V
Load Regulation		I_L = 0mA to 10mA, T_A = +25°C		-6	-10	mV
Power-Supply Sensitivity		V_{DD} ±5%, T_A = +25°C		±1	±3	mV
Temperature Drift (Note 3)		MAX15__C_		40	70	ppm/°C
		MAX15__E_		40	70	
		MAX15__M_		60	100	
Output Noise	eN			200		μV/rms
Capacitive Load					0.01	μF
ANALOG INPUT						
Analog Input Voltage Range	A _{INR}		V_{REF-}		V_{REF+}	V
Analog Input Capacitance	C _{AIN}			45		pF
Analog Input Current	I _{AIN}	Any channel, A _{IN} = 0V to 5V			±3	μA
Slew Rate, Tracking	SR			0.7	0.157	V/μs
LOGIC INPUTS (\overline{RD}, \overline{CS}, A0, A1, A2)						
Input High Voltage	V _{INH}		2.4			V
Input Low Voltage	V _{INL}				0.8	V
Input High Current	I _{INH}				1	μA
Input Low Current	I _{INL}				-1	μA
Input Capacitance (Note 4)	C _{IN}			5	8	pF

CMOS High-Speed 8-Bit ADCs with Multiplexer and Reference

MAX154/MAX158

ELECTRICAL CHARACTERISTICS (continued)

(V_{DD} = +5V, V_{REF+} = +5V, V_{REF-} = GND, MODE 0, T_A = T_{MIN} to T_{MAX}, unless otherwise noted).

PARAMETER	SYMBOL	CONDITIONS	MIN	TYP	MAX	UNITS
LOGIC OUTPUTS						
Output High Voltage	V _{OH}	DB0-DB7, $\overline{\text{INT}}$; I _{OUT} = -360 μ A	4.0			V
Output Low Voltage	V _{OL}	DB0-DB7, $\overline{\text{INT}}$; RDY	I _{OUT} = 1.6mA		0.4	V
			I _{OUT} = 2.6mA		0.4	
Three-State Output Current		DB0-DB7, RDY; V _{OUT} = 0V to V _{DD}			± 3	μ A
Output Capacitance (Note 4)	C _{OUT}			5	8	pF
POWER-SUPPLY						
Supply Voltage	V _{DD}	5V $\pm 5\%$ for specified performance	4.75		5.25	V
Supply Current	I _{DD}	$\overline{\text{CS}} = \overline{\text{RD}} = 2.4\text{V}$			15	mA
Power Dissipation				25	75	mW
Power-Supply Sensitivity	PSS	V _{DD} = $\pm 5\%$		$\pm 1/16$	$\pm 1/4$	LSB

Note 1: Total unadjusted error includes offset, full-scale, and linearity errors.

Note 2: Specified with no external load unless otherwise noted.

Note 3: Temperature drift is defined as change in output voltage from +25°C to T_{MIN} or T_{MAX} divided by (25 - T_{MIN}) or (T_{MAX} - 25).

Note 4: Guaranteed by design.

TIMING CHARACTERISTICS (Note 5)

(V_{DD} = +5V, V_{REF+} = +5V, V_{REF-} = GND, MODE 0, T_A = T_{MIN} to T_{MAX}, unless otherwise noted).

PARAMETER	SYMBOL	CONDITIONS	T _A = +25°C			MAX15_C/E		MAX15_M		UNITS
			MIN	TYP	MAX	MIN	MAX	MIN	MAX	
$\overline{\text{CS}}$ to $\overline{\text{RD}}$ Setup Time	t _{CSS}		0			0		0		ns
$\overline{\text{CS}}$ to $\overline{\text{RD}}$ Hold Time	t _{CSH}		0			0		0		ns
Multiplexer Address Setup Time	t _{AS}		0			0		0		ns
Multiplexer Address Hold Time	t _{AH}		30			35		40		ns
$\overline{\text{CS}}$ to RDY Delay	t _{RDY}	C _L = 50pF, R _L = 5k Ω	30	40		60		60		ns
Conversion Time (Mode 0)	t _{CRD}		1.6	2.0		2.4		2.8		μ s
Data Access Time After $\overline{\text{RD}}$	t _{ACC1}	(Note 6)			85			110		ns
Data Access Time After $\overline{\text{INT}}$, Mode 0	t _{ACC2}	(Note 6)			20			60		ns
$\overline{\text{RD}}$ to $\overline{\text{INT}}$ Delay (Mode 1)	t _{INTH}	C _L = 50pF	40	75		100		100		ns
Data Hold Time	t _{DH}	(Note 7)			60			70		ns
Delay Time Between Conversions	t _P		500			500		600		ns
$\overline{\text{RD}}$ Pulse Width (Mode 1)	t _{RD}		60	600		80	500	80	400	ns

Note 5: All input control signals are specified with t_R = t_F = 20ns (10% to 90% of +5V) and timed from a 1.6V voltage level.

Note 6: Measured with load circuits of Figure 1 and defined as the time required for an output to cross 0.8V or 2.4V.

Note 7: Defined as the time required for the data lines to change 0.5V when loaded with the circuits of Figure 2.

CMOS High-Speed 8-Bit ADCs with Multiplexer and Reference

Typical Operating Characteristics

($T_A = +25^\circ\text{C}$, unless otherwise noted.)

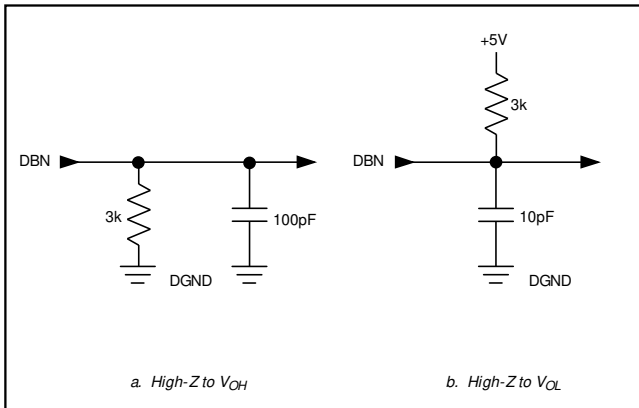
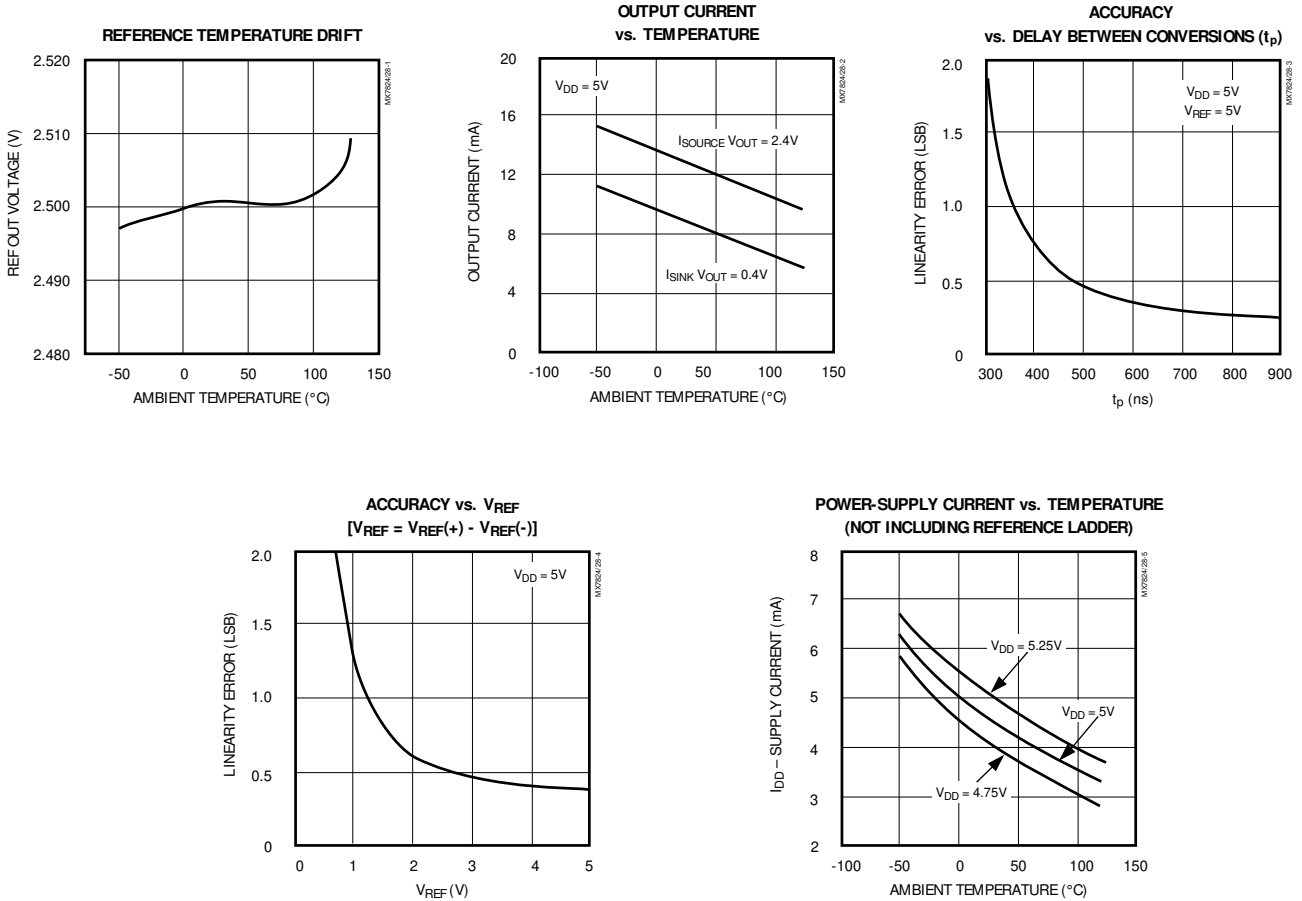

Figure 1. Load Circuits for Data-Access Time Test

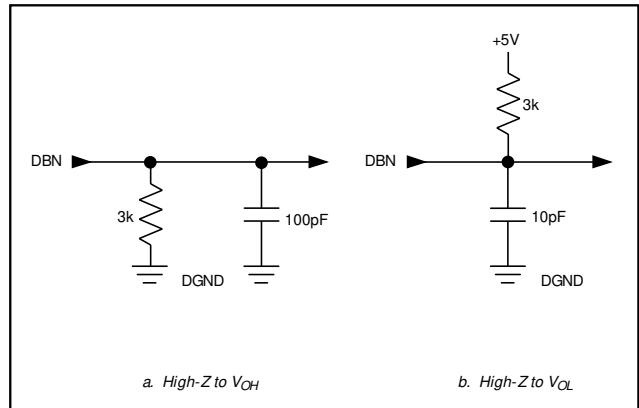

Figure 2. Load Circuits for Data-Hold Time Test

CMOS High-Speed 8-Bit ADCs with Multiplexer and Reference

Pin Descriptions

MAX154/MAX158

PIN MAX154	NAME	FUNCTION
1	AIN4	Analog Input Channel 4
2	AIN3	Analog Input Channel 3
3	AIN2	Analog Input Channel 2
4	AIN1	Analog Input Channel 1
5	REF OUT	Reference Output (2.5V) for MAX154
6	DB0	Three-State Data Output, bit 0 (LSB)
7	DB1	Three-State Data Output, bit 1
8	DB2	Three-State Data Output, bit 2
9	DB3	Three-State Data Output, bit 3
10	\overline{RD}	Read Input. \overline{RD} controls conversions and data access. See <i>Digital Interface</i> section.
11	\overline{INT}	Interrupt Output. \overline{INT} going low indicates the completion of a conversion. See <i>Digital Interface</i> section.
12	GND	Ground
13	VREF-	Lower Limit of Reference Span. Sets the zero-code voltage. Range: GND to VREF+.
14	VREF+	Upper Limit of Reference Span. Sets the full-scale input voltage. Range: VREF- to VDD.
15	RDY	Ready Output. Open-drain output with no active pull-up device. Goes low when \overline{CS} goes low and high impedance at the end of a conversion.
16	\overline{CS}	Chip-Select Input. \overline{CS} must be low for the device to be selected.
17	DB4	Three-State Data Output, bit 4
18	DB5	Three-State Data Output, bit 5
19	DB6	Three-State Data Output, bit 6
20	DB7	Three-State Data Output, bit 7 (MSB)
21	A1	Channel Address 1 Input
22	A0	Channel Address 0 Input
23	NC	No Connect
24	VDD	Power-Supply Voltage, +5V

PIN MAX158	NAME	FUNCTION
1	AIN6	Analog Input Channel 6
2	AIN5	Analog Input Channel 5
3	AIN4	Analog Input Channel 4
4	AIN3	Analog Input Channel 3
5	AIN2	Analog Input Channel 2
6	AIN1	Analog Input Channel 1
7	REF OUT	Reference Output (2.5V) for MAX158
8	DB0	Three-State Data Output, bit 0 (LSB)
9	DB1	Three-State Data Output, bit 1
10	DB2	Three-State Data Output, bit 2
11	DB3	Three-State Data Output, bit 3
12	\overline{RD}	Read Input. \overline{RD} controls conversions and data access. See <i>Digital Interface</i> section.
13	\overline{INT}	Interrupt Output. \overline{INT} going low indicates the completion of a conversion. See <i>Digital Interface</i> section.
14	GND	Ground
15	VREF-	Lower Limit of Reference Span. Sets the zero-code voltage. Range: GND to VREF+.
16	VREF+	Upper Limit of Reference Span. Sets the full-scale input voltage. Range: VREF- to VDD.
17	RDY	Ready Output. Open-drain output with no active pull-up device. Goes low when \overline{CS} goes low and high impedance at the end of a conversion.
18	\overline{CS}	Chip-Select input. \overline{CS} must be low for the device to be selected.
19	DB4	Three-State Data Output, bit 4
20	DB5	Three-State Data Output, bit 5
21	DB6	Three-State Data Output, bit 6
22	DB7	Three-State Data Output, bit 7 (MSB)
23	A2	Channel Address 2 Input
24	A1	Channel Address 1 Input
25	A0	Channel Address 0 Input
26	VDD	Power-Supply Voltage, +5V
27	AIN8	Analog Input Channel 8
28	AIN7	Analog Input Channel 7

CMOS High-Speed 8-Bit ADCs with Multiplexer and Reference

Detailed Description

Converter Operations

The MAX154/MAX158 use what is commonly called a "half-flash" conversion technique (Figure 3). Two 4-bit flash ADC converter sections are used to achieve an 8-bit result. Using 15 comparators, the upper 4-bit MS (most significant) flash ADC compares the unknown input voltage to the reference ladder and provides the upper four data bits.

An internal DAC uses the MS bits to generate an analog signal from the first flash conversion. A residue voltage representing the difference between the unknown input and the DAC voltage is then compared to the reference ladder by 15 LS (least significant) flash comparators to obtain the lower four output bits.

Operating Sequence

The operating sequence is shown in Figure 4. A conversion is initiated by a falling edge of \overline{RD} and \overline{CS} . The comparator inputs track the analog input voltage for approximately 1 μ s. After this first cycle, the MS flash result is latched into the output buffers and the LS conversion begins. \overline{INT} goes low approximately 600ns later, indicating the end of the conversion, and that the lower four bits are latched into the output buffers. The data can then be accessed using the \overline{CS} and \overline{RD} inputs.

Digital Interface

The MAX154/MAX158 use only Chip Select (\overline{CS}) and Read (\overline{RD}) as control inputs. A READ operation, taking \overline{CS} and \overline{RD} low, latches the multiplexer address inputs and starts a conversion (Table 1).

Table 1. Truth Table for Input Channel Selection

MAX154/MX7824		MAX158/MX7828			SELECTED CHANNEL
A1	A0	A2	A1	A0	
0	0	0	0	0	AIN1
0	1	0	0	1	AIN2
1	0	0	1	0	AIN3
1	1	0	1	1	AIN4
		1	0	0	AIN5
		1	0	1	AIN6
		1	1	0	AIN7
		1	1	1	AIN8

There are two interface modes, which are determined by the length of the \overline{RD} input. Mode 0, implemented by keeping \overline{RD} low until the conversion ends, is designed for microprocessors that can be forced into a WAIT state. In this mode, a conversion is started with a READ operation (taking \overline{CS} and \overline{RD} low), and data is read when the conversion ends. Mode 1, on the other hand, does not require microprocessor WAIT states. A READ operation simultaneously initiates a conversion and reads the previous conversion result.

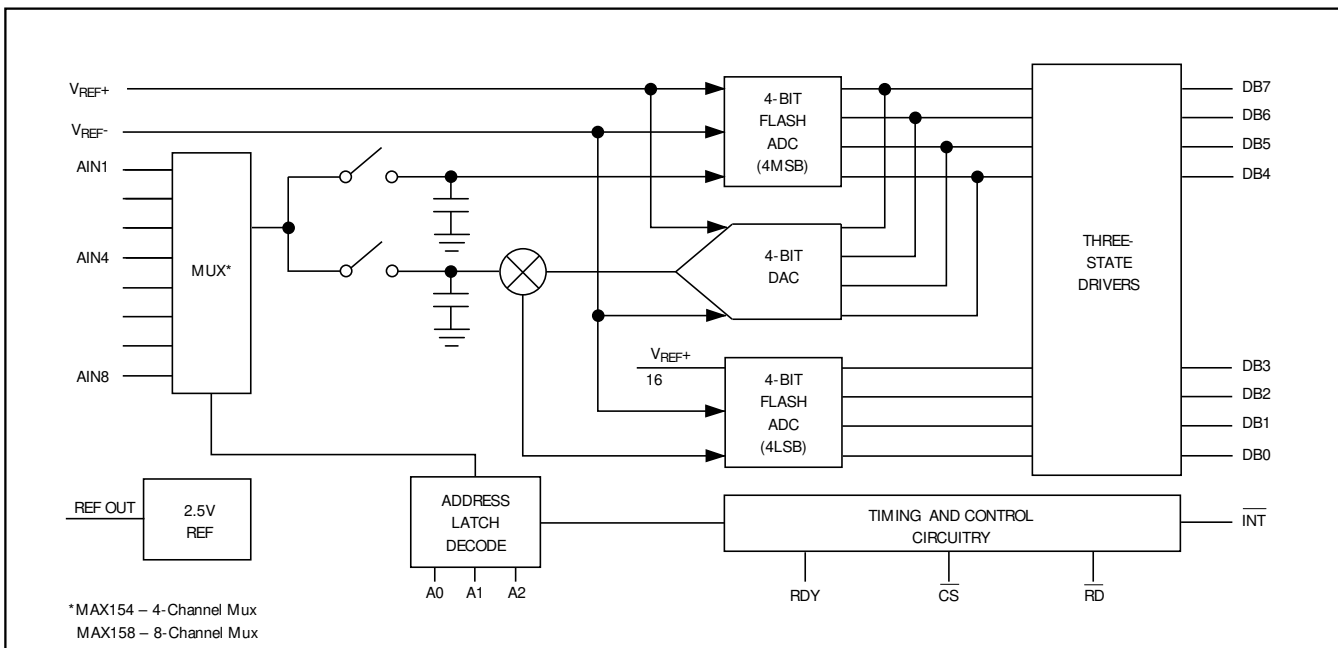

Figure 3. Functional Diagram

CMOS High-Speed 8-Bit ADCs with Multiplexer and Reference

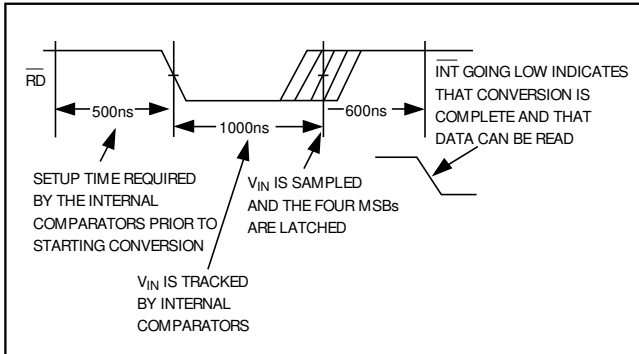

Figure 4. Operating Sequence

Interface Mode 0

Figure 5 shows the timing diagram for Mode 0 operation. This is used with microprocessors that have WAIT state capability, whereby a READ instruction is extended to accommodate slow-memory devices. Taking \overline{CS} and \overline{RD} low latches the analog multiplexer address and starts a conversion. Data outputs DB0–DB7 remain in the high-impedance condition until the conversion is complete.

There are two status outputs: Interrupt (\overline{INT}) and Ready (RDY). RDY, an open-drain output (no internal pull-up

device), is connected to the processor's READY/WAIT input. RDY goes low on the falling edge of \overline{CS} and goes high impedance at the end of the conversion, when the conversion result appears on the data outputs. If the RDY output is not required, its external pull-up resistor can be omitted. \overline{INT} goes low when the conversion is complete and returns high on the rising edge of \overline{CS} or \overline{RD} .

Interface Mode 1

Mode 1 is designed for applications where the microprocessor is not forced into a WAIT state. Taking \overline{CS} and \overline{RD} low latches the multiplexer address and starts a conversion (Figure 6). Data from the previous conversion is immediately read from the outputs (DB0–DB7).

\overline{INT} goes high at the rising edge of \overline{CS} or \overline{RD} and goes low at the end of the conversion. A second READ operation is required to read the result of this conversion. The second READ latches a new multiplexer address and starts another conversion. A delay of 2.5 μ s must be allowed between READ operations. RDY goes low on the falling edge of \overline{CS} and goes high impedance at the rising edge of \overline{CS} . If RDY is not needed, its external pull-up resistor can be omitted.

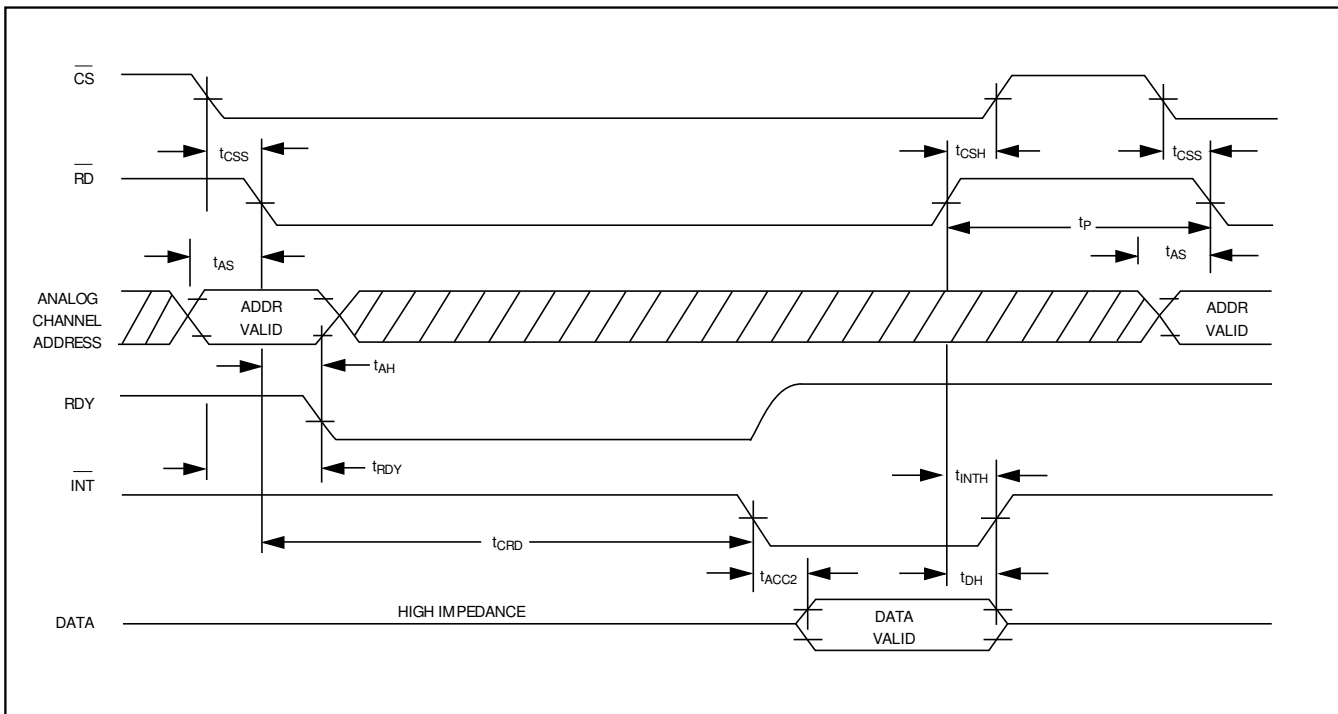

Figure 5. Mode 0 Timing Diagram

CMOS High-Speed 8-Bit ADCs with Multiplexer and Reference

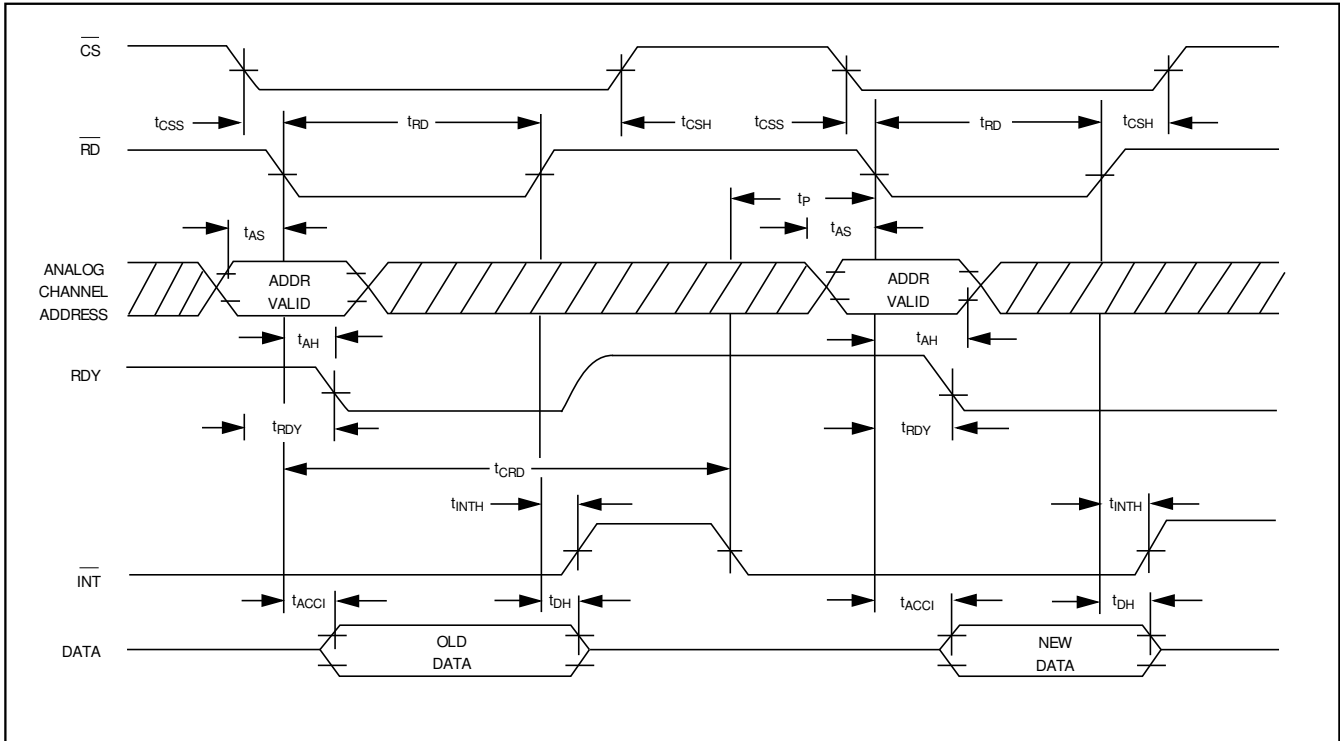

Figure 6. Mode 1 Timing Diagram

Analog Considerations

Reference and Input

The V_{REF+} and V_{REF-} inputs of the converter define the zero and the full-scale of the ADC. In other words, the voltage at V_{REF-} is equal to the input voltage that produces an output code of all zeros, and the voltage at V_{REF+} is equal to input voltage that produces an output code of all ones (Figure 7).

Figure 8 shows some possible reference configurations. A $0.01\mu\text{F}$ bypass capacitor to GND should be used to reduce the high-frequency output impedance of the internal reference. Larger capacitors should not be used, as this degrades the stability of the reference buffer. The 2.5V reference output is with respect to the GND pin.

Bypassing

A $47\mu\text{F}$ electrolytic and $0.1\mu\text{F}$ ceramic capacitor should be used to bypass the V_{DD} pin to GND. These capacitors must have minimum lead length, since excess lead length may contribute to conversion errors and instability. If the reference inputs are driven by long lines, they should be bypassed to GND with $0.1\mu\text{F}$ capacitors at the reference input pins.

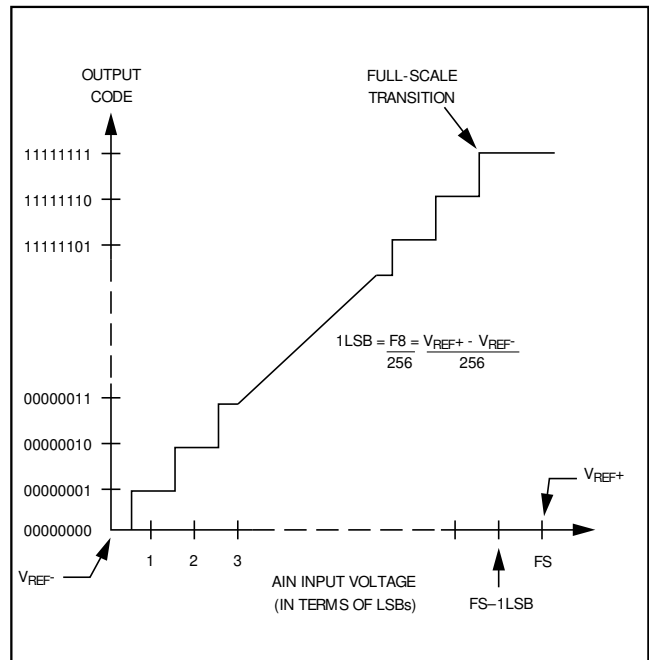

Figure 7. Transfer Function

CMOS High-Speed 8-Bit ADCs with Multiplexer and Reference

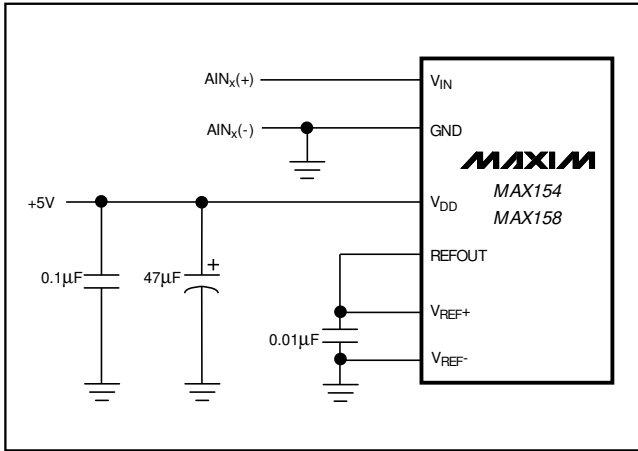

Figure 8a. Internal Reference

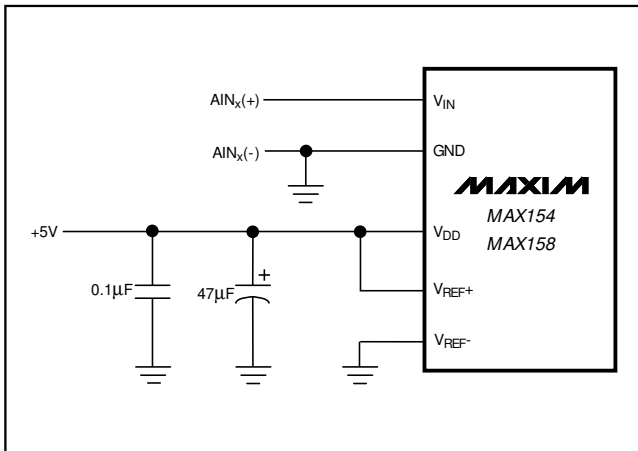

Figure 8b. Power Supply as Reference

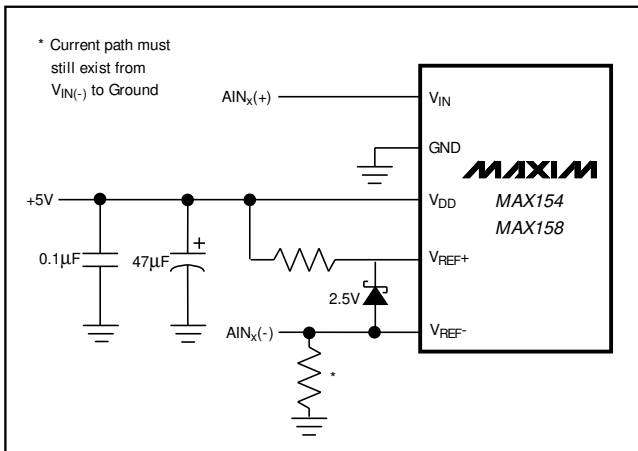

Figure 8c. Inputs Not Referenced to GND

Input Current

The converters' analog inputs behave somewhat differently from conventional ADCs. The sampled data comparators take varying amounts of current from the input, depending on the cycle they are in. The equivalent circuit of the converter is shown in Figure 9a. When the conversion starts, AIN(n) is connected to the MS and LS comparators. Thus, AIN(n) is connected to thirty-one 1pF capacitors.

To acquire the input signal in approximately 1µs, the input capacitors must charge to the input voltage through the on-resistance of the multiplexer (about 600Ω) and the comparator's analog switches (2kΩ to 5kΩ per comparator). In addition, about 12pF of stray capacitance must be charged. The input can be modeled as an equivalent RC network shown in Figure 9b. As R_S (source impedance) increases, the capacitors take longer to charge.

Since the length of the input acquisition time is internally set, large source resistances (greater than 100Ω) will cause settling errors. The output impedance of an op-amp is its open-loop output impedance divided by the loop gain at the frequency of interest. It is important that the amplifier driving the converter input have sufficient loop gain at approximately 1MHz to maintain low output impedance.

Input Filtering

The transients in the analog input caused by the sampled data comparators do not degrade the converter's performance, since the ADC does not "look" at the input when these transients occur. The comparator's outputs track the input during the first 1µs of the conversion, and are then latched. Therefore, at least 1µs will be provided to charge the ADC's input capacitance. It is not necessary to filter these transients with an external capacitor on the AIN terminals.

Sinusoidal Inputs

The MAX154/MAX158 can measure input signals with slew rates as high as 157mV/µs to the rated specifications. This means that the analog input frequency can be as high as 10kHz without the aid of an external track/hold. The maximum sampling rate is limited by the conversion time (typical t_{CRD} = 2µs) plus the time required between conversions (t_p = 500ns). It is calculated as:

$$f_{MAX} = \frac{1}{t_{CRD} + t_p} = \frac{1}{(2.0 + 0.5) \mu s} = 400kHz$$

f_{MAX} permits a maximum sampling rate of 50kHz per channel when using the MAX158 and 100kHz per channel when using the MAX154. These rates are well above the Nyquist requirement of 20kHz sampling rate for a 10kHz input bandwidth.

CMOS High-Speed 8-Bit ADCs with Multiplexer and Reference

Bipolar Input Operation

The circuit in Figure 10a can be used for bipolar input operation. The input voltage is scaled by an amplifier so that only positive voltages appear at the ADC's inputs. The analog input range is $\pm 4V$ and the output code is complementary offset binary. The ideal input/output characteristic is shown in Figure 10b.

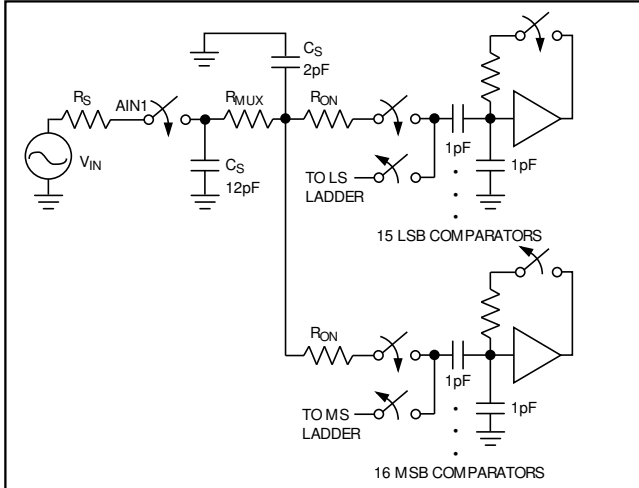

Figure 9a. Equivalent Input Circuit

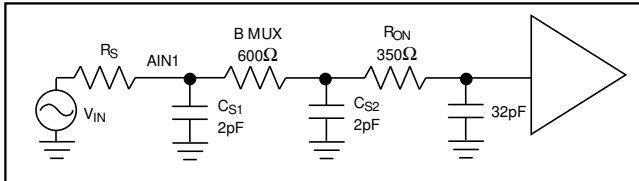

Figure 9b. RC Network Model

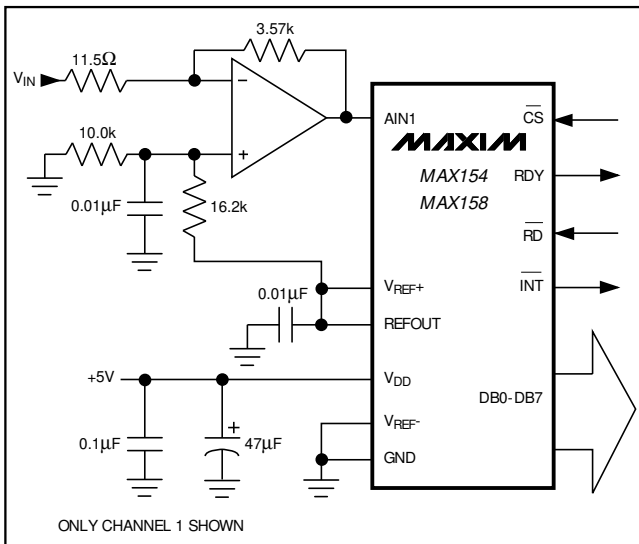

Figure 10a. Bipolar $\pm 4V$ Input Operation

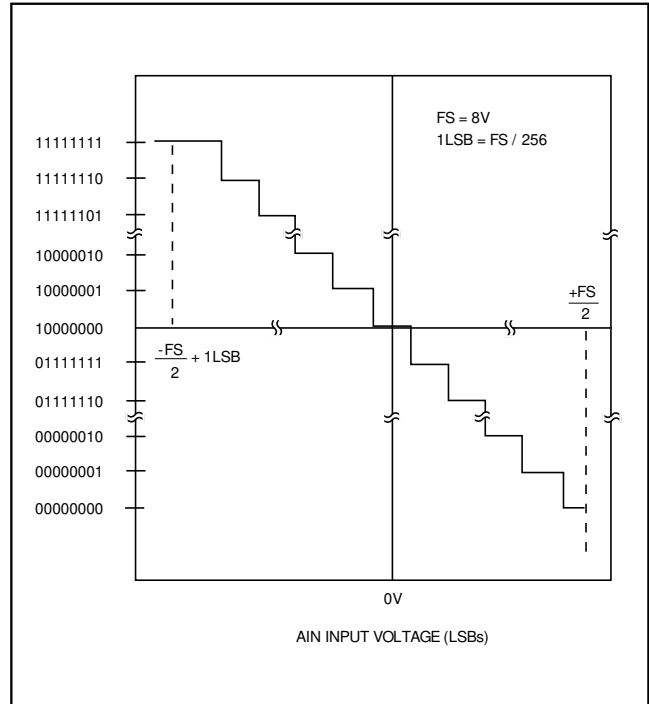

Figure 10b. Transfer Function for $\pm 4V$ Input Operation

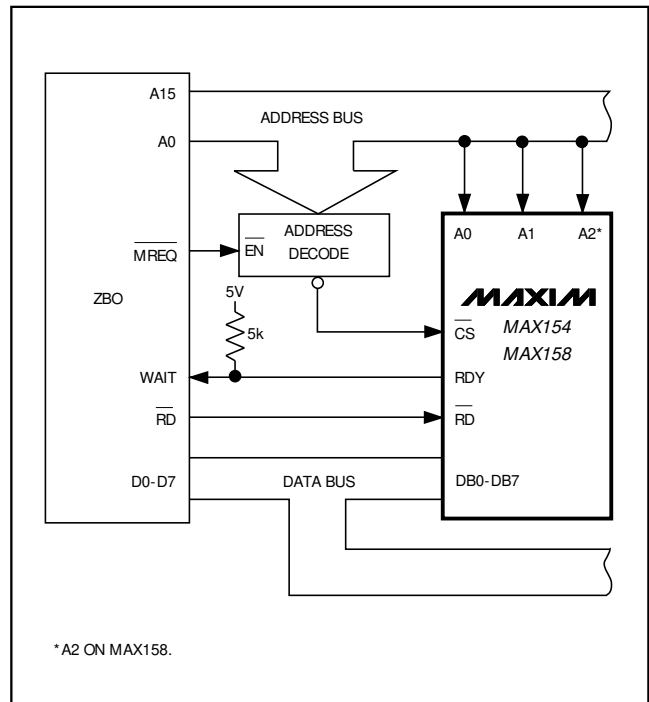

Figure 11. Simple Mode 0 Interface

CMOS High-Speed 8-Bit ADCs with Multiplexer and Reference

MAX154/MAX158

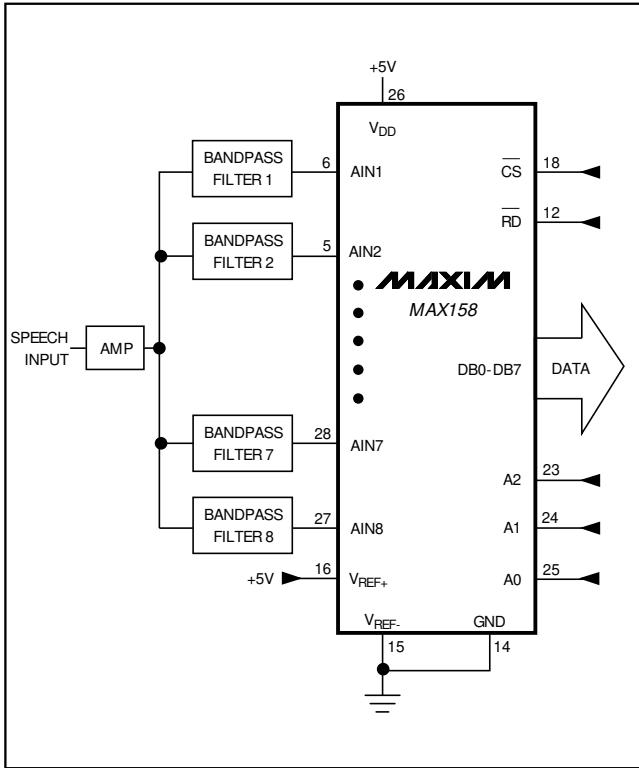

Figure 12. Speech Analysis Using Real-Time Filtering

Ordering Information (continued)

PART	TEMP. RANGE	PIN-PACKAGE	ERROR (LSB)
MAX154AENG	-40°C to +85°C	24 Plastic DIP	$\pm 1/2$
MAX154BENG	-40°C to +85°C	24 Plastic DIP	± 1
MAX154AEWG	-40°C to +85°C	24 Wide SO	$\pm 1/2$
MAX154BEWG	-40°C to +85°C	24 Wide SO	± 1
MAX154AEAG	-40°C to +85°C	24 SSOP	$\pm 1/2$
MAX154BEAG	-40°C to +85°C	24 SSOP	± 1
MAX154AMRG	-55°C to +125°C	24 CERDIP	$\pm 1/2$
MAX154BMRG	-55°C to +125°C	24 CERDIP	± 1
MAX158ACPI	0°C to +70°C	28 Plastic DIP	$\pm 1/2$
MAX158BCPI	0°C to +70°C	28 Plastic DIP	± 1
MAX158BC/D	0°C to +70°C	Dice	$\pm 1/2$
MAX158ACWI	0°C to +70°C	28 Wide SO	$\pm 1/2$
MAX158BCWI	0°C to +70°C	28 Wide SO	± 1
MAX158ACAI	0°C to +70°C	28 SSOP	$\pm 1/2$
MAX158BCAI	0°C to +70°C	28 SSOP	± 1
MAX158AEPI	-40°C to +70°C	28 Plastic DIP	$\pm 1/2$
MAX158BEPI	-40°C to +85°C	28 Plastic DIP	± 1
MAX158AEWI	-40°C to +85°C	28 Wide SO	$\pm 1/2$
MAX158BEWI	-40°C to +85°C	28 Wide SO	± 1
MAX158AEAI	-40°C to +85°C	28 SSOP	$\pm 1/2$
MAX158BEAI	-40°C to +85°C	28 SSOP	± 1
MAX158AMJI	-55°C to +125°C	28 CERDIP	$\pm 1/2$
MAX158BMJI	-55°C to +125°C	28 CERDIP	± 1

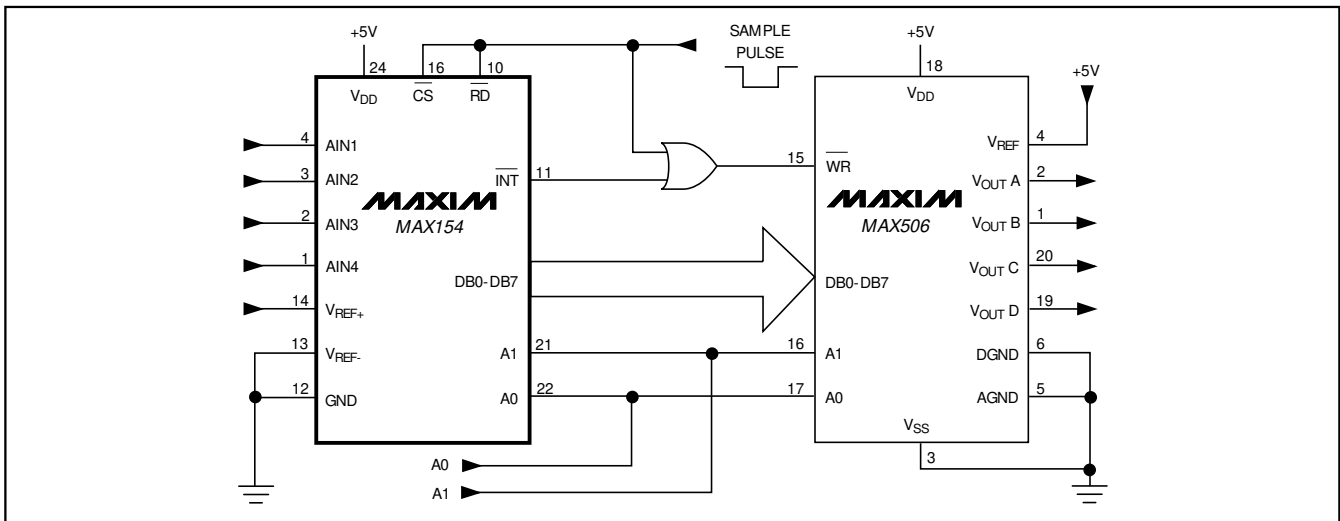
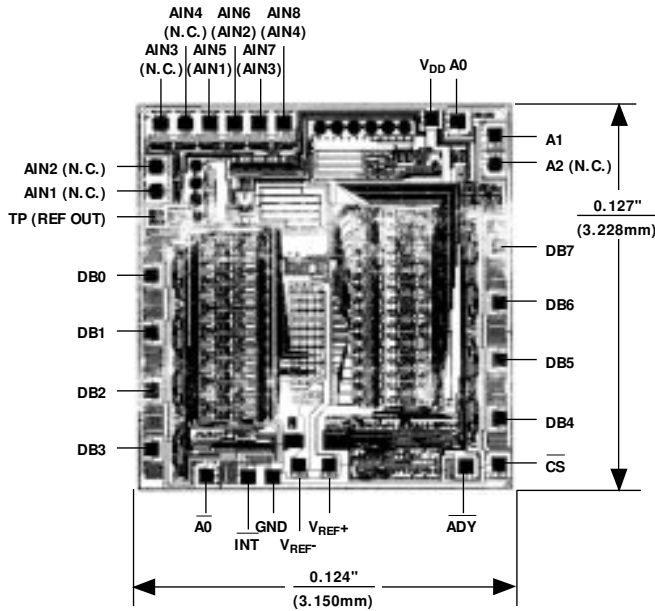

Figure 13. 4-Channel Fast Sample and Infinite Hold

CMOS High-Speed 8-Bit ADCs with Multiplexer and Reference

Chip Topography



() ARE FOR MAX154/MX7824

Package Information

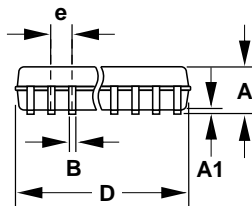
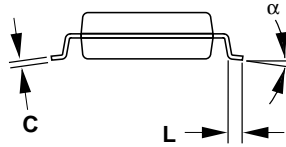
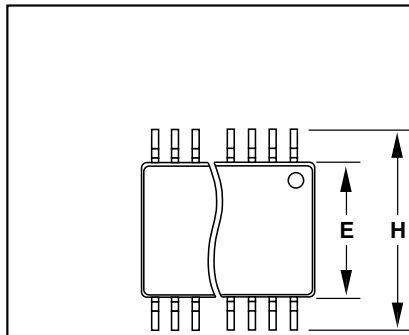

**SSOP
SHRINK
SMALL-OUTLINE
PACKAGE**

DIM	INCHES		MILLIMETERS	
	MIN	MAX	MIN	MAX
A	0.068	0.078	1.73	1.99
A1	0.002	0.008	0.05	0.21
B	0.010	0.015	0.25	0.38
C	0.004	0.008	0.09	0.20
D	SEE VARIATIONS			
E	0.205	0.209	5.20	5.38
e	0.0256 BSC		0.65 BSC	
H	0.301	0.311	7.65	7.90
L	0.025	0.037	0.63	0.95
α	0°	8°	0°	8°

DIM	PINS	INCHES		MILLIMETERS	
		MIN	MAX	MIN	MAX
D	14	0.239	0.249	6.07	6.33
D	16	0.239	0.249	6.07	6.33
D	20	0.278	0.289	7.07	7.33
D	24	0.317	0.328	8.07	8.33
D	28	0.397	0.407	10.07	10.33

21-0056A

Maxim cannot assume responsibility for use of any circuitry other than circuitry entirely embodied in a Maxim product. No circuit patent licenses are implied. Maxim reserves the right to change the circuitry and specifications without notice at any time.

12 Maxim Integrated Products, 120 San Gabriel Drive, Sunnyvale, CA 94086 (408) 737-7600

SITE
SEARCHPART NO
SEARCH

WHAT'S NEW

PRODUCTS

SOLUTIONS

DESIGN

APPNOTES

SUPPORT

BUY

COMPANY

MEMBERS

[Maxim](#) > [Products](#) > [Analog-to-Digital Converters](#)

MAX154, MAX158

CMOS High-Speed, 8-Bit ADCs with Multiplexer and Reference

[QuickView](#)[Technical Documents](#)[Ordering Info](#)[More Information](#)[All](#)

Ordering Information

Notes:

- Other options and links for purchasing parts are listed at: <http://www.maxim-ic.com/sales>.
- [Didn't Find What You Need?](#) Ask our applications engineers. Expert assistance in finding parts, usually within one business day.
- Part number suffixes: T or T&R = tape and reel; + = RoHS/lead-free; # = RoHS/lead-exempt. More: See [Full Data Sheet](#) or [Part Naming Conventions](#).
- * Some packages have variations, listed on the drawing. "PkgCode/Variation" tells which variation the product uses.

Devices: 1-93 of 93

MAX154	Free Sample	Buy	Package: TYPE PINS FOOTPRINT DRAWING CODE/VAR *	Temp	RoHS/Lead-Free? Materials Analysis
MAX154BEAG+				-40C to +85C	RoHS/Lead-Free: See data sheet
MAX154AMRG+				-55C to +125C	RoHS/Lead-Free: See data sheet
MAX154BMRG			Ceramic DIP;24 pin;256 mm Dwg: 21-0045A (PDF) Use pkgcode/variation: R24-4*	-55C to +125C	RoHS/Lead-Free: No Materials Analysis
MAX154AMRG			Ceramic DIP;24 pin;256 mm Dwg: 21-0045A (PDF) Use pkgcode/variation: R24-4*	-55C to +125C	RoHS/Lead-Free: No Materials Analysis
MAX154AMRG/883B			Ceramic DIP;24 pin;256 mm Dwg: 21-0045A (PDF) Use pkgcode/variation: R24-4*	-55C to +125C	RoHS/Lead-Free: No Materials Analysis
MAX154BMRG/883B			Ceramic DIP;24 pin;256 mm Dwg: 21-0045A (PDF) Use pkgcode/variation: R24-4*	-55C to +125C	RoHS/Lead-Free: No Materials Analysis
MAX154BC/D					RoHS/Lead-Free: See data sheet
MAX154BCNG			PDIP;24 pin;265 mm Dwg: 21-0043D (PDF) Use pkgcode/variation: N24-1*	0C to +70C	RoHS/Lead-Free: No Materials Analysis
MAX154BCNG+			PDIP;24 pin;265 mm Dwg: 21-0043D (PDF) Use pkgcode/variation: N24+1*	0C to +70C	RoHS/Lead-Free: Lead Free Materials Analysis
MAX154ACNG			PDIP;24 pin;265 mm Dwg: 21-0043D (PDF) Use pkgcode/variation: N24-1*	0C to +70C	RoHS/Lead-Free: No Materials Analysis
MAX154ACNG+			PDIP;24 pin;265 mm Dwg: 21-0043D (PDF) Use pkgcode/variation: N24+1*	0C to +70C	RoHS/Lead-Free: Lead Free Materials Analysis
MAX154AENG+			PDIP;24 pin;265 mm Dwg: 21-0043D (PDF) Use pkgcode/variation: N24+1*	-40C to +85C	RoHS/Lead-Free: Lead Free Materials Analysis
MAX154BENG+			PDIP;24 pin;265 mm Dwg: 21-0043D (PDF) Use pkgcode/variation: N24+1*	-40C to +85C	RoHS/Lead-Free: Lead Free Materials Analysis

MAX154AENG			PDIP;24 pin;265 mm Dwg: 21-0043D (PDF) Use pkgcode/variation: N24-1*	-40C to +85C	RoHS/Lead-Free: No Materials Analysis
MAX154BENG			PDIP;24 pin;265 mm Dwg: 21-0043D (PDF) Use pkgcode/variation: N24-1*	-40C to +85C	RoHS/Lead-Free: No Materials Analysis
MAX154ACWG+T			SOIC;24 pin;166 mm Dwg: 21-0042B (PDF) Use pkgcode/variation: W24+1*	0C to +70C	RoHS/Lead-Free: Lead Free Materials Analysis
MAX154BCWG+T			SOIC;24 pin;166 mm Dwg: 21-0042B (PDF) Use pkgcode/variation: W24+1*	0C to +70C	RoHS/Lead-Free: Lead Free Materials Analysis
MAX154ACWG+			SOIC;24 pin;166 mm Dwg: 21-0042B (PDF) Use pkgcode/variation: W24+1*	0C to +70C	RoHS/Lead-Free: Lead Free Materials Analysis
MAX154BCWG+			SOIC;24 pin;166 mm Dwg: 21-0042B (PDF) Use pkgcode/variation: W24+1*	0C to +70C	RoHS/Lead-Free: Lead Free Materials Analysis
MAX154ACWG			SOIC;24 pin;166 mm Dwg: 21-0042B (PDF) Use pkgcode/variation: W24-1*	0C to +70C	RoHS/Lead-Free: No Materials Analysis
MAX154BCWG-T			SOIC;24 pin;166 mm Dwg: 21-0042B (PDF) Use pkgcode/variation: W24-1*	0C to +70C	RoHS/Lead-Free: No Materials Analysis
MAX154ACWG-T			SOIC;24 pin;166 mm Dwg: 21-0042B (PDF) Use pkgcode/variation: W24-1*	0C to +70C	RoHS/Lead-Free: No Materials Analysis
MAX154BCWG			SOIC;24 pin;166 mm Dwg: 21-0042B (PDF) Use pkgcode/variation: W24-1*	0C to +70C	RoHS/Lead-Free: No Materials Analysis
MAX154BEWG-T			SOIC;24 pin;166 mm Dwg: 21-0042B (PDF) Use pkgcode/variation: W24-1*	-40C to +85C	RoHS/Lead-Free: No Materials Analysis
MAX154AEWG			SOIC;24 pin;166 mm Dwg: 21-0042B (PDF) Use pkgcode/variation: W24-1*	-40C to +85C	RoHS/Lead-Free: No Materials Analysis
MAX154AEWG+T			SOIC;24 pin;166 mm Dwg: 21-0042B (PDF) Use pkgcode/variation: W24+1*	-40C to +85C	RoHS/Lead-Free: Lead Free Materials Analysis
MAX154BEWG+T			SOIC;24 pin;166 mm Dwg: 21-0042B (PDF) Use pkgcode/variation: W24+1*	-40C to +85C	RoHS/Lead-Free: Lead Free Materials Analysis
MAX154BEWG+			SOIC;24 pin;166 mm Dwg: 21-0042B (PDF) Use pkgcode/variation: W24+1*	-40C to +85C	RoHS/Lead-Free: Lead Free Materials Analysis
MAX154AEWG+			SOIC;24 pin;166 mm Dwg: 21-0042B (PDF) Use pkgcode/variation: W24+1*	-40C to +85C	RoHS/Lead-Free: Lead Free Materials Analysis
MAX154BEWG			SOIC;24 pin;166 mm Dwg: 21-0042B (PDF) Use pkgcode/variation: W24-1*	-40C to +85C	RoHS/Lead-Free: No Materials Analysis
MAX154AEWG-T			SOIC;24 pin;166 mm Dwg: 21-0042B (PDF) Use pkgcode/variation: W24-1*	-40C to +85C	RoHS/Lead-Free: No Materials Analysis
MAX154BCAG+T			SSOP;24 pin;66 mm Dwg: 21-0056C (PDF) Use pkgcode/variation: A24+2*	0C to +70C	RoHS/Lead-Free: Lead Free Materials Analysis
MAX154ACAG-T			SSOP;24 pin;66 mm Dwg: 21-0056C (PDF) Use pkgcode/variation: A24-2*	0C to +70C	RoHS/Lead-Free: No Materials Analysis
MAX154BCAG+			SSOP;24 pin;66 mm Dwg: 21-0056C (PDF) Use pkgcode/variation: A24+2*	0C to +70C	RoHS/Lead-Free: Lead Free Materials Analysis
MAX154ACAG+T			SSOP;24 pin;66 mm Dwg: 21-0056C (PDF) Use pkgcode/variation: A24+2*	0C to +70C	RoHS/Lead-Free: Lead Free Materials Analysis
MAX154ACAG+			SSOP;24 pin;66 mm Dwg: 21-0056C (PDF) Use pkgcode/variation: A24+2*	0C to +70C	RoHS/Lead-Free: Lead Free Materials Analysis

MAX154BCAG			SSOP;24 pin;66 mm Dwg: 21-0056C (PDF) Use pkgcode/variation: A24-2*	0C to +70C	RoHS/Lead-Free: No Materials Analysis
MAX154BCAG-T			SSOP;24 pin;66 mm Dwg: 21-0056C (PDF) Use pkgcode/variation: A24-2*	0C to +70C	RoHS/Lead-Free: No Materials Analysis
MAX154ACAG			SSOP;24 pin;66 mm Dwg: 21-0056C (PDF) Use pkgcode/variation: A24-2*	0C to +70C	RoHS/Lead-Free: No Materials Analysis
MAX154AEAG+			SSOP;24 pin;66 mm Dwg: 21-0056C (PDF) Use pkgcode/variation: A24+2*	-40C to +85C	RoHS/Lead-Free: Lead Free Materials Analysis
MAX154BEAG-T			SSOP;24 pin;66 mm Dwg: 21-0056C (PDF) Use pkgcode/variation: A24-2*	-40C to +85C	RoHS/Lead-Free: No Materials Analysis
MAX154AEAG			SSOP;24 pin;66 mm Dwg: 21-0056C (PDF) Use pkgcode/variation: A24-2*	-40C to +85C	RoHS/Lead-Free: No Materials Analysis
MAX154BEAG+T				-40C to +85C	RoHS/Lead-Free: See data sheet
MAX154AEAG-T			SSOP;24 pin;66 mm Dwg: 21-0056C (PDF) Use pkgcode/variation: A24-2*	-40C to +85C	RoHS/Lead-Free: No Materials Analysis
MAX154BEAG			SSOP;24 pin;66 mm Dwg: 21-0056C (PDF) Use pkgcode/variation: A24-2*	-40C to +85C	RoHS/Lead-Free: No Materials Analysis
MAX154AEAG+T			SSOP;24 pin;66 mm Dwg: 21-0056C (PDF) Use pkgcode/variation: A24+2*	-40C to +85C	RoHS/Lead-Free: Lead Free Materials Analysis
MAX158	Free Sample	Buy	Package: TYPE PINS FOOTPRINT DRAWING CODE/VAR *	Temp	RoHS/Lead-Free? Materials Analysis
MAX158AEPI+				-40C to +85C	RoHS/Lead-Free: See data sheet
MAX158BEPI+				-40C to +85C	RoHS/Lead-Free: See data sheet
MAX158BEJI			Ceramic DIP;28 pin;606 mm Dwg: 21-0046A (PDF) Use pkgcode/variation: J28-2*	-40C to +85C	RoHS/Lead-Free: No Materials Analysis
MAX158AEJI			Ceramic DIP;28 pin;606 mm Dwg: 21-0046A (PDF) Use pkgcode/variation: J28-2*	-40C to +85C	RoHS/Lead-Free: No Materials Analysis
MAX158BMJI			Ceramic DIP;28 pin;606 mm Dwg: 21-0046A (PDF) Use pkgcode/variation: J28-2*	-55C to +125C	RoHS/Lead-Free: No Materials Analysis
MAX158AMJI			Ceramic DIP;28 pin;606 mm Dwg: 21-0046A (PDF) Use pkgcode/variation: J28-2*	-55C to +125C	RoHS/Lead-Free: No Materials Analysis
MAX158AMJI/883B			Ceramic DIP;28 pin;606 mm Dwg: 21-0046A (PDF) Use pkgcode/variation: J28-2*	-55C to +125C	RoHS/Lead-Free: No Materials Analysis
MAX158BMJI/883B			Ceramic DIP;28 pin;606 mm Dwg: 21-0046A (PDF) Use pkgcode/variation: J28-2*	-55C to +125C	RoHS/Lead-Free: No Materials Analysis
MAX158BC/D					RoHS/Lead-Free: See data sheet
MAX158BCPI+			PDIP;28 pin;593 mm Dwg: 21-0044B (PDF) Use pkgcode/variation: P28+1*	0C to +70C	RoHS/Lead-Free: Lead Free Materials Analysis
MAX158ACPI			PDIP;28 pin;593 mm Dwg: 21-0044B (PDF) Use pkgcode/variation: P28-1*	0C to +70C	RoHS/Lead-Free: No Materials Analysis
MAX158ACPI+			PDIP;28 pin;593 mm Dwg: 21-0044B (PDF) Use pkgcode/variation: P28+1*	0C to +70C	RoHS/Lead-Free: Lead Free Materials Analysis

MAX158BCPI			PDIP;28 pin;593 mm Dwg: 21-0044B (PDF) Use pkgcode/variation: P28-1*	0C to +70C	RoHS/Lead-Free: No Materials Analysis
MAX158AEPI			PDIP;28 pin;593 mm Dwg: 21-0044B (PDF) Use pkgcode/variation: P28-1*	-40C to +85C	RoHS/Lead-Free: No Materials Analysis
MAX158BEPI			PDIP;28 pin;593 mm Dwg: 21-0044B (PDF) Use pkgcode/variation: P28-1*	-40C to +85C	RoHS/Lead-Free: No Materials Analysis
MAX158BCWI+			SOIC;28 pin;193 mm Dwg: 21-0042B (PDF) Use pkgcode/variation: W28+1*	0C to +70C	RoHS/Lead-Free: Lead Free Materials Analysis
MAX158BCWI+T			SOIC;28 pin;193 mm Dwg: 21-0042B (PDF) Use pkgcode/variation: W28+1*	0C to +70C	RoHS/Lead-Free: Lead Free Materials Analysis
MAX158ACWI			SOIC;28 pin;193 mm Dwg: 21-0042B (PDF) Use pkgcode/variation: W28-1*	0C to +70C	RoHS/Lead-Free: No Materials Analysis
MAX158ACWI+			SOIC;28 pin;193 mm Dwg: 21-0042B (PDF) Use pkgcode/variation: W28+1*	0C to +70C	RoHS/Lead-Free: Lead Free Materials Analysis
MAX158ACWI+T			SOIC;28 pin;193 mm Dwg: 21-0042B (PDF) Use pkgcode/variation: W28+1*	0C to +70C	RoHS/Lead-Free: Lead Free Materials Analysis
MAX158BCWI-T			SOIC;28 pin;193 mm Dwg: 21-0042B (PDF) Use pkgcode/variation: W28-1*	0C to +70C	RoHS/Lead-Free: No Materials Analysis
MAX158BCWI			SOIC;28 pin;193 mm Dwg: 21-0042B (PDF) Use pkgcode/variation: W28-1*	0C to +70C	RoHS/Lead-Free: No Materials Analysis
MAX158ACWI-T			SOIC;28 pin;193 mm Dwg: 21-0042B (PDF) Use pkgcode/variation: W28-1*	0C to +70C	RoHS/Lead-Free: No Materials Analysis
MAX158BEWI+T			SOIC;28 pin;193 mm Dwg: 21-0042B (PDF) Use pkgcode/variation: W28+1*	-40C to +85C	RoHS/Lead-Free: Lead Free Materials Analysis
MAX158AEWI+			SOIC;28 pin;193 mm Dwg: 21-0042B (PDF) Use pkgcode/variation: W28+1*	-40C to +85C	RoHS/Lead-Free: Lead Free Materials Analysis
MAX158AEWI+T			SOIC;28 pin;193 mm Dwg: 21-0042B (PDF) Use pkgcode/variation: W28+1*	-40C to +85C	RoHS/Lead-Free: Lead Free Materials Analysis
MAX158BEWI+			SOIC;28 pin;193 mm Dwg: 21-0042B (PDF) Use pkgcode/variation: W28+1*	-40C to +85C	RoHS/Lead-Free: Lead Free Materials Analysis
MAX158AEWI			SOIC;28 pin;193 mm Dwg: 21-0042B (PDF) Use pkgcode/variation: W28-1*	-40C to +85C	RoHS/Lead-Free: No Materials Analysis
MAX158BEWI-T			SOIC;28 pin;193 mm Dwg: 21-0042B (PDF) Use pkgcode/variation: W28-1*	-40C to +85C	RoHS/Lead-Free: No Materials Analysis
MAX158AEWI-T			SOIC;28 pin;193 mm Dwg: 21-0042B (PDF) Use pkgcode/variation: W28-1*	-40C to +85C	RoHS/Lead-Free: No Materials Analysis
MAX158BEWI			SOIC;28 pin;193 mm Dwg: 21-0042B (PDF) Use pkgcode/variation: W28-1*	-40C to +85C	RoHS/Lead-Free: No Materials Analysis
MAX158BCAI+			SSOP;28 pin;82 mm Dwg: 21-0056C (PDF) Use pkgcode/variation: A28+1*	0C to +70C	RoHS/Lead-Free: Lead Free Materials Analysis
MAX158ACAI-T			SSOP;28 pin;82 mm Dwg: 21-0056C (PDF) Use pkgcode/variation: A28-1*	0C to +70C	RoHS/Lead-Free: No Materials Analysis
MAX158BCAI+T			SSOP;28 pin;82 mm Dwg: 21-0056C (PDF) Use pkgcode/variation: A28+1*	0C to +70C	RoHS/Lead-Free: Lead Free Materials Analysis
MAX158BCAI-T			SSOP;28 pin;82 mm Dwg: 21-0056C (PDF) Use pkgcode/variation: A28-1*	0C to +70C	RoHS/Lead-Free: No Materials Analysis

MAX158BCAI			SSOP;28 pin;82 mm Dwg: 21-0056C (PDF) Use pkgcode/variation: A28-1*	0C to +70C	RoHS/Lead-Free: No Materials Analysis
MAX158ACAI			SSOP;28 pin;82 mm Dwg: 21-0056C (PDF) Use pkgcode/variation: A28-1*	0C to +70C	RoHS/Lead-Free: No Materials Analysis
MAX158ACAI+T			SSOP;28 pin;82 mm Dwg: 21-0056C (PDF) Use pkgcode/variation: A28+1*	0C to +70C	RoHS/Lead-Free: Lead Free Materials Analysis
MAX158ACAI+			SSOP;28 pin;82 mm Dwg: 21-0056C (PDF) Use pkgcode/variation: A28+1*	0C to +70C	RoHS/Lead-Free: Lead Free Materials Analysis
MAX158BEAI+			SSOP;28 pin;82 mm Dwg: 21-0056C (PDF) Use pkgcode/variation: A28+1*	-40C to +85C	RoHS/Lead-Free: Lead Free Materials Analysis
MAX158BEAI+T			SSOP;28 pin;82 mm Dwg: 21-0056C (PDF) Use pkgcode/variation: A28+1*	-40C to +85C	RoHS/Lead-Free: Lead Free Materials Analysis
MAX158BEAI-T			SSOP;28 pin;82 mm Dwg: 21-0056C (PDF) Use pkgcode/variation: A28-1*	-40C to +85C	RoHS/Lead-Free: No Materials Analysis
MAX158BEAI			SSOP;28 pin;82 mm Dwg: 21-0056C (PDF) Use pkgcode/variation: A28-1*	-40C to +85C	RoHS/Lead-Free: No Materials Analysis
MAX158AEAI+			SSOP;28 pin;82 mm Dwg: 21-0056C (PDF) Use pkgcode/variation: A28+1*	-40C to +85C	RoHS/Lead-Free: Lead Free Materials Analysis
MAX158AEAI-T			SSOP;28 pin;82 mm Dwg: 21-0056C (PDF) Use pkgcode/variation: A28-1*	-40C to +85C	RoHS/Lead-Free: No Materials Analysis
MAX158AEAI			SSOP;28 pin;82 mm Dwg: 21-0056C (PDF) Use pkgcode/variation: A28-1*	-40C to +85C	RoHS/Lead-Free: No Materials Analysis
MAX158AEAI+T			SSOP;28 pin;82 mm Dwg: 21-0056C (PDF) Use pkgcode/variation: A28+1*	-40C to +85C	RoHS/Lead-Free: Lead Free Materials Analysis

Didn't Find What You Need?

- [Next Day Product Selection Assistance from Applications Engineers](#)
- [Parametric Search](#)
- [Applications Help](#)

QuickView

[Description](#)
[Key Features](#)
[Applications/Uses](#)
[Key Specifications](#)
[Diagram](#)

Technical Documents

[Data Sheet](#)
[Application Notes](#)
[Design Guides](#)
[Engineering Journals](#)
[Reliability Reports](#)
[Software/Models](#)
[Evaluation Kits](#)

Ordering Info

[Price and Availability](#)
[Samples](#)
[Buy Online](#)
[Package Information](#)
[Lead-Free Information](#)

More Information

[Related Products](#)
[Notes and Comments](#)
[Evaluation Kits](#)

Document Ref.: 19-0892; Rev 3; 1996-12-01
This page last modified: 2007-05-29

[CONTACT US: SEND US AN EMAIL](#)