



# FireWire Current Limiter and Low-Drop ORing Switch Controller

MAX5943

## General Description

The MAX5943 is a fully integrated power-management IC for FireWire® applications. This device controls two external power n-channel MOSFETs to regulate current from the input power supply to the load and performs low-voltage-drop, power-supply ORing. The MAX5943 operates over a 7.5V to 37V input range and provides inrush and output current limit in addition to a diode ORing function suitable for FireWire applications. The MAX5943 FireWire/IEEE 1394™ protective circuit (Figure 12) is UL® recognized.

The MAX5943 allows the safe insertion and removal of FireWire peripherals into a live FireWire port by providing inrush current control and an output current-limiting function. The ORing feature provides a very efficient way to protect the FireWire port when connected to another FireWire peripheral that sources a higher voltage. By turning off both external MOSFETs, the MAX5943 provides a true bidirectional load disconnect. A low-current shutdown mode disables the MAX5943, resulting in less than 10µA supply current. A pin-selectable input allows latched or autoretry fault management after a fault.

The MAX5943A features a current-limit function that actively limits the current drawn by the load with a programmable timeout. The MAX5943B–MAX5943E do not actively limit the load current but provide a circuit-breaker function. See the *Selector Guide* for the default and programmable circuit-breaker timeouts.

The MAX5943 operates over the -40°C to +85°C extended temperature range and is available in a 16-pin QSOP package.

## Applications

FireWire Desktop/Notebook Port  
FireWire Peripheral Device Current Limit  
FireWire Hub  
Hot Swap

**Typical Operating Circuit and Selector Guide appear at end of data sheet.**

FireWire is a registered trademark of Apple Computers, Inc.

IEEE 1394 is a trademark of the Institute of Electrical and Electronics Engineers trademark.

UL is a registered trademark of Underwriters Laboratories, Inc.

## Features

- ◆ Provides Safe Hot Swap for 7.5V to 37V Power Supplies
- ◆ UL-Recognized FireWire/IEEE 1394 Protective Circuit
- ◆ Low-Drop Power ORing with Ultra-Fast Turn-Off
- ◆ Programmable Active Current Limit (MAX5943A)
- ◆ Programmable Circuit Breaker (MAX5943B–MAX5943E)
- ◆ ±5% Current-Limit Sensing Accuracy
- ◆ Programmable Current-Limit/Circuit-Breaker Timeout
- ◆ Fast Current-Limit Response to Output Short-Circuit Conditions (MAX5943A)
- ◆ Drives External N-Channel Power MOSFETs
- ◆ Overcurrent Fault Status Output
- ◆ Latched or Autoretry Overcurrent Fault Management
- ◆ 10µA Shutdown Current
- ◆ ON/OFF Control Allows Undervoltage Lockout Programming
- ◆ Fast Load Disconnect Control Through ON Input

## Ordering Information

PART	TEMP RANGE	PIN-PACKAGE
MAX5943AEEE	-40°C to +85°C	16 QSOP
MAX5943BEEE	-40°C to +85°C	16 QSOP
MAX5943CEEE	-40°C to +85°C	16 QSOP
MAX5943DEEE	-40°C to +85°C	16 QSOP
MAX5943EEEE	-40°C to +85°C	16 QSOP

## Pin Configuration

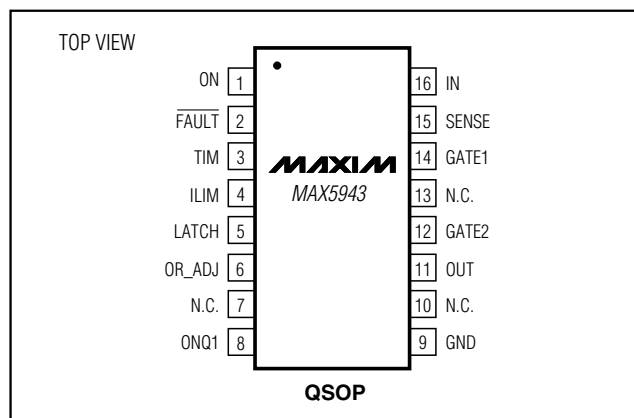

# FireWire Current Limiter and Low-Drop ORing Switch Controller

## ABSOLUTE MAXIMUM RATINGS

(Voltages referenced to GND, unless otherwise noted.)

IN	-0.3V to +80V
OUT	-0.3V to +80V
SENSE to IN	-1V to +0.3V
GATE1 to SENSE	-0.3V to +8V
GATE2 to OUT (internally clamped)	-0.3V to +8V
FAULT	-0.3V to +85V
ON, TIM, ILIM, LATCH, OR_ADJ, ONQ1	-0.3V to (IN + 0.3V)

Continuous Power Dissipation (T<sub>A</sub> = +70°C)

16-Pin QSOP (derate 8.3mW/°C above +70°C)	667mW
Operating Temperature Range	-40°C to +85°C
Maximum Junction Temperature	+150°C
Storage Temperature Range	-60°C to +150°C
ESD Rating (Human Body Model)	2000V
Lead Temperature (soldering, 10s)	+300°C

Stresses beyond those listed under "Absolute Maximum Ratings" may cause permanent damage to the device. These are stress ratings only, and functional operation of the device at these or any other conditions beyond those indicated in the operational sections of the specifications is not implied. Exposure to absolute maximum rating conditions for extended periods may affect device reliability.

## ELECTRICAL CHARACTERISTICS

(V<sub>IN</sub> = 7.5V to 37V, GND = 0V, and T<sub>A</sub> = -40°C to +85°C, unless otherwise noted. Typical values are at V<sub>IN</sub> = 12V, T<sub>A</sub> = +25°C.) (Note 1)

PARAMETER	SYMBOL	CONDITIONS	MIN	TYP	MAX	UNITS	
<b>SUPPLIES</b>							
Supply Voltage Range	V <sub>IN</sub>		7.5		37	V	
Supply Current	I <sub>IN</sub>	V <sub>ON</sub> = 3V, no load		1.3	2.3	mA	
Shutdown Current	I <sub>SD</sub>	V <sub>ON</sub> = 0.4V		5	10	μA	
IN Default Undervoltage Lockout	V <sub>UVLO</sub>	V <sub>IN</sub> rising, ON = IN	6.2	6.5	6.8	V	
IN Default Undervoltage Lockout Hysteresis				0.35		V	
ON Undervoltage Lockout Threshold	V <sub>ON_REF</sub>	V <sub>ON</sub> rising	1.20	1.24	1.275	V	
ON Undervoltage Lockout Threshold Hysteresis				70		mV	
ON Input Bias Current	I <sub>ON</sub>				1	μA	
<b>GATE2 (current-limit/circuit-breaker control)</b>							
GATE2 Pullup Current	I <sub>G2U</sub>	(Note 2)	36	45	54	μA	
GATE2 High Voltage	V <sub>G2</sub>	V <sub>GATE2</sub> - V <sub>OUT</sub>	7.5V ≤ V <sub>IN</sub> ≤ 8V	4.25	5.5	6.5	V
			8V ≤ V <sub>IN</sub> ≤ 37V	4.5	5.5	6.5	
Current-Limit/Circuit-Breaker Threshold Voltage	V <sub>TH</sub>	V <sub>IN</sub> - V <sub>SENSE</sub>	ILIM = GND	47.5	50	52.5	mV
			ILIM = floating	37	39	41	
			ILIM = IN	55	58.5	61	
Fast Pulldown Current-Limit Threshold Voltage (MAX5943A)	V <sub>THF</sub>	V <sub>IN</sub> - V <sub>SENSE</sub> (Note 3)	ILIM = GND	70	75	80	mV
			ILIM = floating	54	59	64	
			ILIM = IN	83	88	93	
GATE2 Pulldown Current (MAX5943A)	I <sub>G2D</sub>	V <sub>TH</sub> < (V <sub>IN</sub> - V <sub>SENSE</sub> ) < V <sub>THF</sub> , t < t <sub>ILIM</sub>	335	435	535	μA	
GATE2 Fast Pulldown Current (MAX5943A)	I <sub>G2DF</sub>	(V <sub>IN</sub> - V <sub>SENSE</sub> ) > V <sub>THF</sub> , V <sub>GATE2</sub> = V <sub>OUT</sub> + 4.5V	80	125	200	mA	
GATE2 Peak Pulldown Current (MAX5943A)	I <sub>G2DP</sub>	(V <sub>IN</sub> - V <sub>SENSE</sub> ) = 1V		1.0		A	

# FireWire Current Limiter and Low-Drop ORing Switch Controller

**MAX5943**

## ELECTRICAL CHARACTERISTICS (continued)

( $V_{IN} = 7.5V$  to  $37V$ ,  $GND = 0V$ , and  $T_A = -40^{\circ}C$  to  $+85^{\circ}C$ , unless otherwise noted. Typical values are at  $V_{IN} = 12V$ ,  $T_A = +25^{\circ}C$ .)  
(Note 1)

PARAMETER	SYMBOL	CONDITIONS		MIN	TYP	MAX	UNITS
GATE2 Pulldown Current During Any GATE2 Turn-Off Condition	$I_{G2OFF}$	$V_{GATE2} = V_{OUT} + 4.5V$ (Note 4)		80	125	200	mA
<b>GATE1 (ORing control)</b>							
ORing Switch Turn-On Current Threshold Voltage	$V_{OR}$	$(V_{IN} - V_{SENSE})$ rising	OR_ADJ = GND	3	5	7	mV
			OR_ADJ = floating	5.5	7.5	9.5	
			OR_ADJ = IN	8.5	10.5	12.8	
ORing Switch Turn-On Current Threshold Voltage Hysteresis		$(V_{IN} - V_{SENSE})$ falling		0.5		mV	
GATE1 Pullup Current	$I_{G1U}$	(Note 5)		36	45	54	$\mu A$
GATE1 High Voltage	$V_{G1}$	$V_{GATE1} - V_{SENSE}$	$7.5V \leq V_{IN} \leq 8V$	4.25	5.5	6.5	V
			$8V \leq V_{IN} \leq 37V$	4.5	5.5	6.5	
GATE1 Turn-Off Switch On-Resistance	$R_{G1}$	Measured between GATE1 and SENSE when $(V_{IN} - V_{SENSE}) < V_{OR}$			2	3	$\Omega$
<b>LOGIC INPUTS</b>							
ILIM, OR_ADJ Input-Logic Tristate Current Tolerance (Note 6)	$I_{IX}$	Current into or out of input for tri-state logic condition		-3		+3	$\mu A$
		Current out of input for logic low				20	
		Current into input for logic high				20	
LATCH, ONQ1 Input-Logic Low Voltage	$V_{IL}$	$V_{ON} > V_{ON\_REF}$				0.7	V
		LATCH, ONQ1 = GND, $V_{ON} > V_{ON\_REF}$				1	
LATCH, ONQ1 Input-Logic High Voltage	$V_{IH}$	$V_{ON} > V_{ON\_REF}$		1.8			V
LATCH, ONQ1 Input Current	$I_{IH}$	All voltages = $V_{IN}$ , $V_{ON} > V_{ON\_REF}$				1	$\mu A$
TIM, ILIM, LATCH, OR_ADJ, OUT, ONQ1 Shutdown Mode Input Current	$I_{IH\_SD}$	All voltages = $V_{IN}$ , $V_{ON} \leq 0.4V$				1	$\mu A$
FAULT Output Low Voltage	$V_{OL}$	Low-impedance state, $I_{\overline{FAULT}} = 5mA$			0.12	0.25	V
FAULT Output High Leakage Current	$I_{OH}$	High-impedance state, $V_{\overline{FAULT}} = 37V$				1	$\mu A$
<b>TIMING</b>							
Current-Limit Timeout (MAX5943A)	$t_{LIM}$	Current-limit mode (Note 7)	TIM = IN	1.78	2.02	2.26	ms
			$R_{TIM} = 4k\Omega$	0.87	1.04	1.21	ms
			$R_{TIM} = 50k\Omega$	9.2	11.05	12.9	ms
			TIM = floating	120	175	225	ms

# FireWire Current Limiter and Low-Drop ORing Switch Controller

## ELECTRICAL CHARACTERISTICS (continued)

( $V_{IN} = 7.5V$  to  $37V$ ,  $GND = 0V$ , and  $T_A = -40^{\circ}C$  to  $+85^{\circ}C$ , unless otherwise noted. Typical values are at  $V_{IN} = 12V$ ,  $T_A = +25^{\circ}C$ .) (Note 1)

PARAMETER	SYMBOL	CONDITIONS	MIN	TYP	MAX	UNITS	
Circuit-Breaker Timeout (MAX5943B–MAX5943E) (Note 7)	$t_{CB}$	Circuit-breaker mode, MAX5943B	TIM = IN or TIM $\geq 3.4V$	0.45	0.51	0.57	ms
			$R_{TIM} = 4k\Omega$	27	32.5	38	$\mu s$
			$R_{TIM} = 50k\Omega$	228	345	403	$\mu s$
			TIM = floating	3.75	5.5	7	ms
		Circuit-breaker mode, MAX5943C	TIM = IN or TIM $\geq 3.4V$	0.89	1.00	1.13	ms
			$R_{TIM} = 4k\Omega$	54	65	76	$\mu s$
			$R_{TIM} = 50k\Omega$	575	690	806	$\mu s$
			TIM = floating	7.5	10.9	14	ms
		Circuit-breaker mode, MAX5943D	TIM = IN	1.78	2.02	2.26	ms
			$R_{TIM} = 4k\Omega$	109	130	151	$\mu s$
			$R_{TIM} = 50k\Omega$	1.15	1.38	1.61	ms
		Circuit-breaker mode, MAX5943E	TIM = floating	15	21.9	28	ms
			TIM = IN or TIM $\geq 3.4V$	3.56	4.05	4.52	ms
			$R_{TIM} = 4k\Omega$	217	260	303	$\mu s$
			$R_{TIM} = 50k\Omega$	2.3	2.76	3.23	ms
				TIM = floating	30	44	56
Automatic Restart Delay After Current-Limit/Circuit-Breaker Timeout	$t_{OFF}$	LATCH = GND (Note 8)		128 x ( $t_{LIM}$ OR $t_{CB}$ )		ms	
GATE1 Turn-Off Time (ORing Response Time)	$t_{OR}$	From $V_{OR}$ trigger until $(V_{GATE1} - V_{IN}) < 1V$ , $C_{GATE1} = 10nF$		100		ns	
Turn-Off Response Time	$t_{ON\_OFF}$	Time from $V_{ON} < (V_{ON\_OFF} - \text{Hysteresis})$ until $(V_{GATE2} - V_{OUT}) < 1V$ , GATE2 = open (Note 9)		0.34	0.6	$\mu s$	
Minimum Delay from ON Low to Low-Current Shutdown Mode	$t_{SD}$	ON step from 1.3V to 0.4V		50		$\mu s$	

**Note 1:** All min/max parameters are tested at  $+25^{\circ}C$  and  $+85^{\circ}C$ . Limits at  $-40^{\circ}C$  are guaranteed by design.

**Note 2:** Measured at both  $V_{GATE2} = V_{OUT} = 0V$  and  $V_{GATE2} = V_{OUT} = V_{IN}$ .

**Note 3:** The typical value of parameter  $V_{THF}$  is  $1.5 \times V_{TH}$ .

**Note 4:** Current-Limit/Circuit-Breaker Timeout; IN or ON low.

**Note 5:** See the *Typical Operating Circuit*. Measured at  $V_{GATE1} = V_{SENSE}$ .

**Note 6:** The tristate ("floating") logic condition will be entered if the pin current is within these limits.

**Note 7:**  $R_{TIM}$  is connected from TIM to GND. The maximum timeout period is enforced to prevent arbitrarily long operation in current-limit mode. Therefore, the relationship between resistor value and timeout changes for large values of  $R_{TIM}$ . See Current-Limit Timeout vs.  $R_{TIM}$  in the *Typical Operating Characteristics* for nominal values.

**Note 8:** Parameter  $t_{OFF}$  is a direct multiple of  $t_{LIM}$  (or  $t_{CB}$ ), so the limits for  $t_{OFF}$  track the limits for  $t_{LIM}$  (or  $t_{CB}$ ).

**Note 9:** If the ON voltage goes below  $V_{ON\_REF} - \text{Hysteresis}$ , then GATE2 goes low immediately to disconnect power from the load quickly (within  $t_{ON\_OFF}$ ).

# FireWire Current Limiter and Low-Drop ORing Switch Controller

## Typical Operating Characteristics

( $V_{IN} = +12V$ ,  $T_A = +25^\circ C$ , unless otherwise noted.)

MAX5943

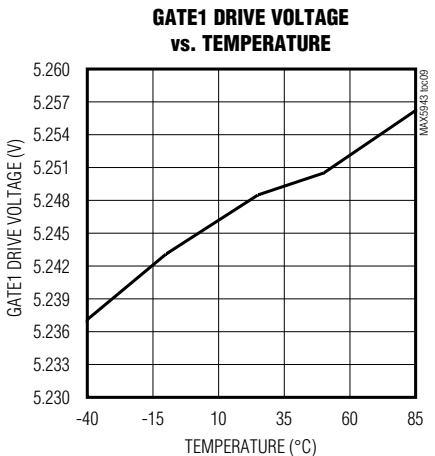
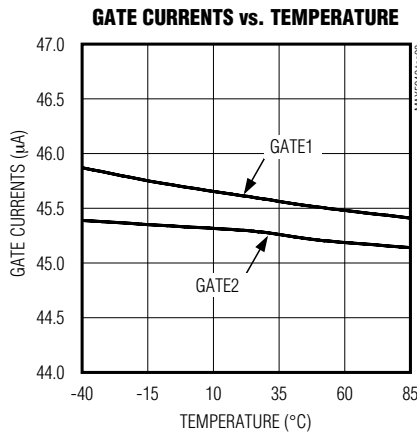
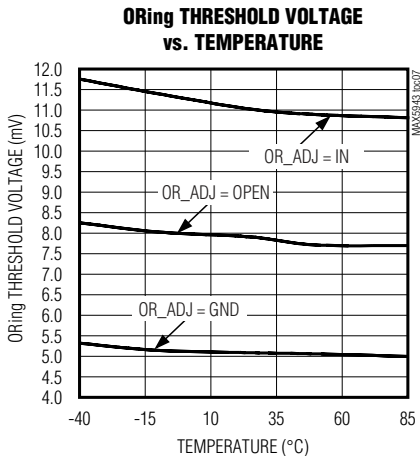
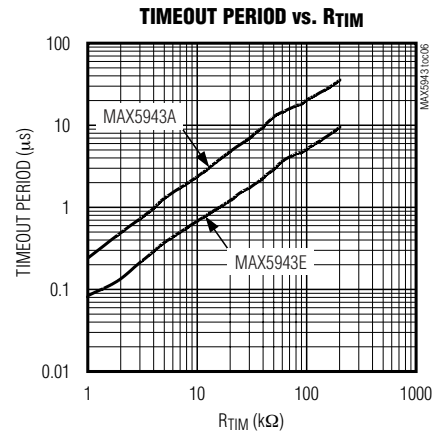
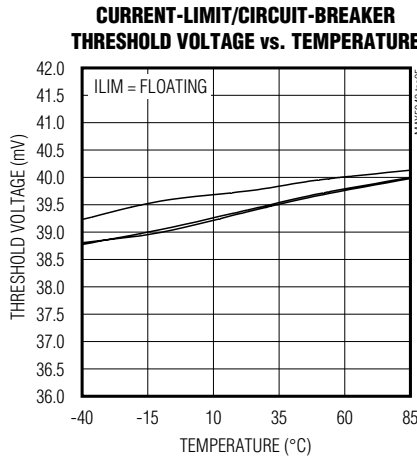
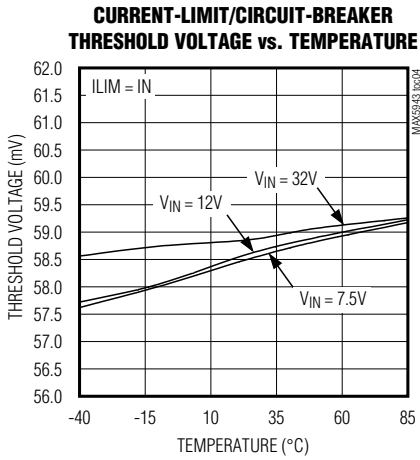
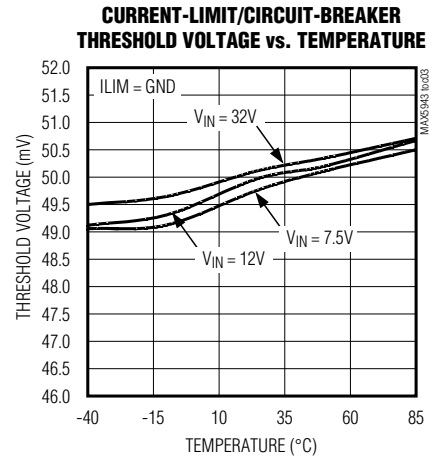
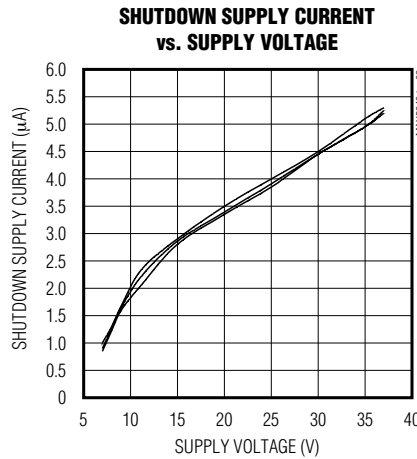
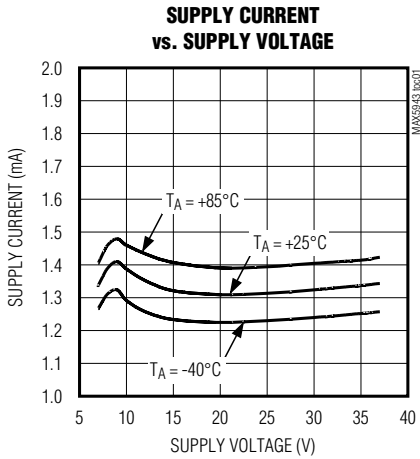

# FireWire Current Limiter and Low-Drop ORing Switch Controller

## Typical Operating Characteristics (continued)

( $V_{IN} = +12V$ ,  $T_A = +25^\circ C$ , unless otherwise noted.)

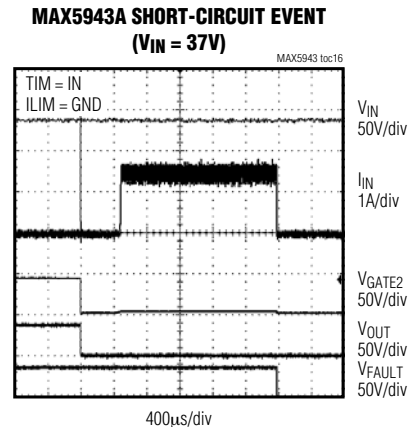
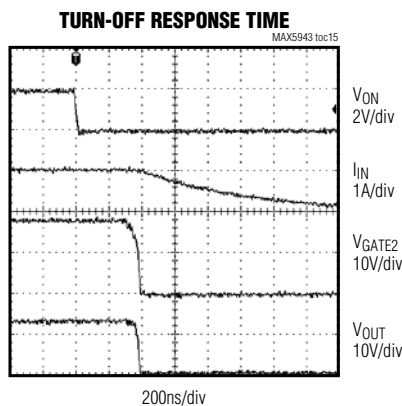
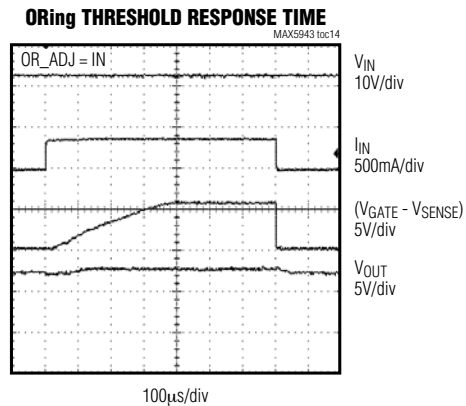
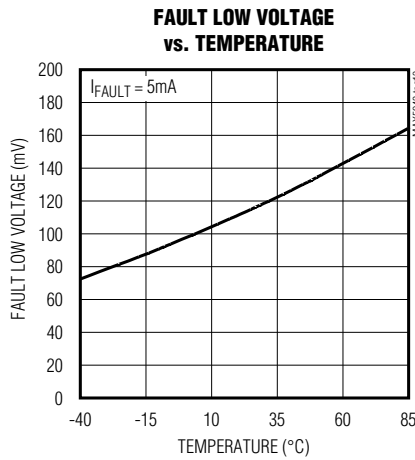
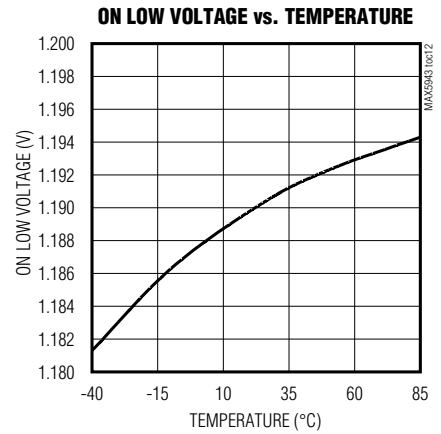
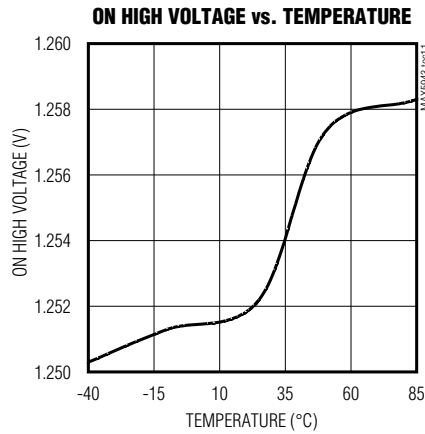
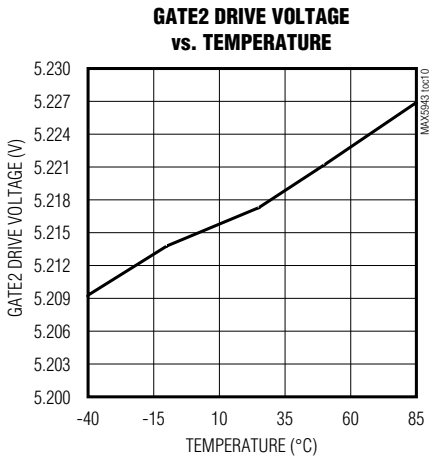

# FireWire Current Limiter and Low-Drop ORing Switch Controller

## Typical Operating Characteristics (continued)

( $V_{IN} = +12V$ ,  $T_A = +25^\circ C$ , unless otherwise noted.)

**MAX5943**

**MAX5943A SHORT-CIRCUIT EVENT**  
( $V_{IN} = 37V$ )

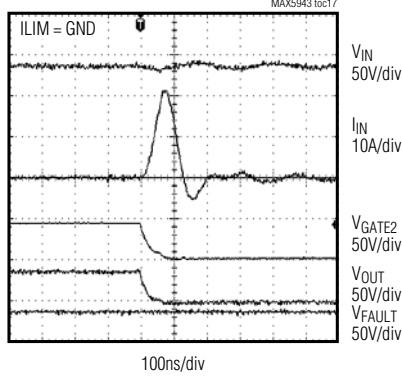

**MAX5943A SHORT-CIRCUIT RESPONSE**  
( $V_{IN} = 8V$ )

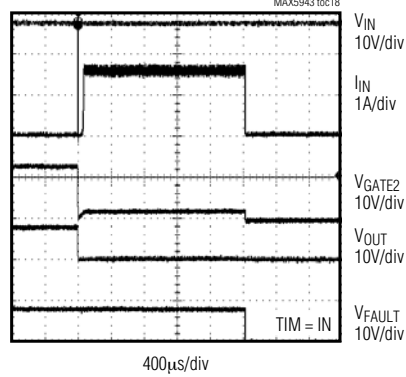

**MAX5943A SHORT-CIRCUIT RESPONSE**  
( $V_{IN} = 8V$ )

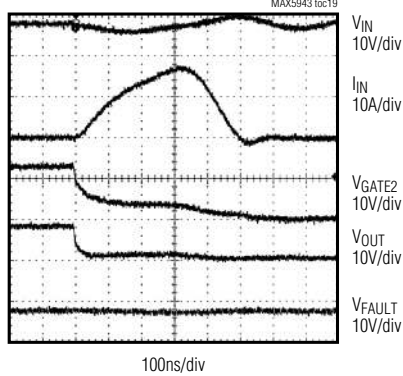

**MAX5943E SHORT-CIRCUIT RESPONSE**  
( $V_{IN} = 24V$ )

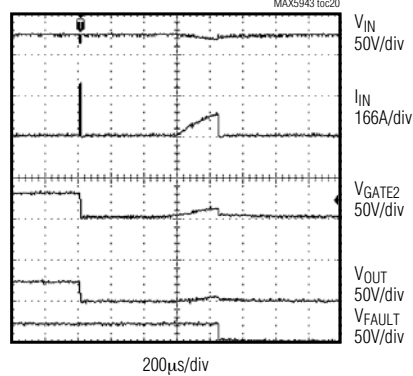

**MAX5943E SHORT-CIRCUIT RESPONSE**  
( $V_{IN} = 8V$ )

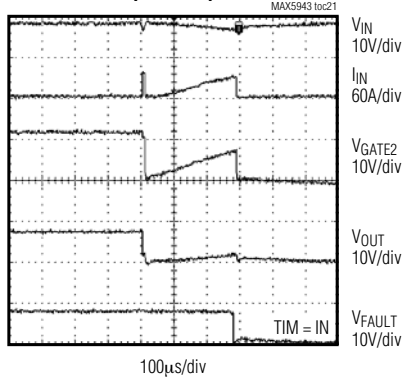

**ORing SWITCHOVER WAVEFORM**

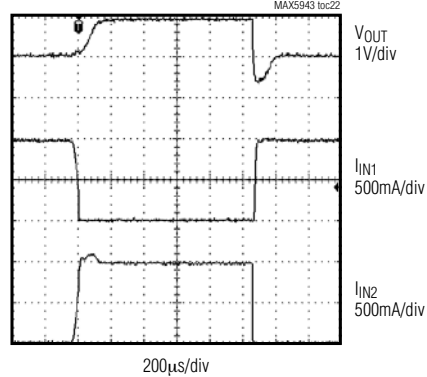

$V_{IN1} = 12V$   
 $V_{IN2} = 128V$

$V_{ON2} \text{ RISING} = 12V$   
 $C_{OUT} = 0$

# FireWire Current Limiter and Low-Drop ORing Switch Controller

## Typical Operating Characteristics (continued)

( $V_{IN} = +12V$ ,  $T_A = +25^\circ C$ , unless otherwise noted.)

**ORing SWITCHOVER WAVEFORM  
( $V_{IN2}$  RISING ABOVE  $V_{IN1}$ )**

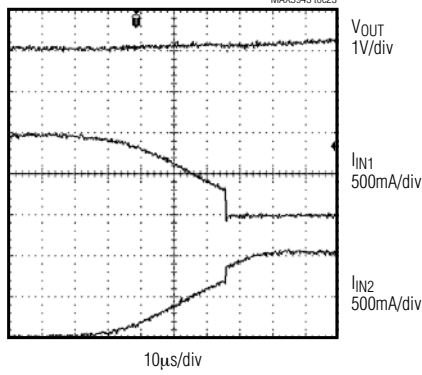

**ORing SWITCHOVER WAVEFORM  
( $V_{IN2}$  FALLING BELOW  $V_{IN1}$ )**

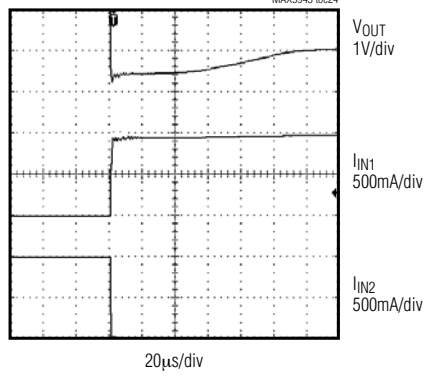

**MAX5943A HOT PLUG-IN LOAD CAPACITANCE  
INTO ACTIVE PORT (NO FAULT)**

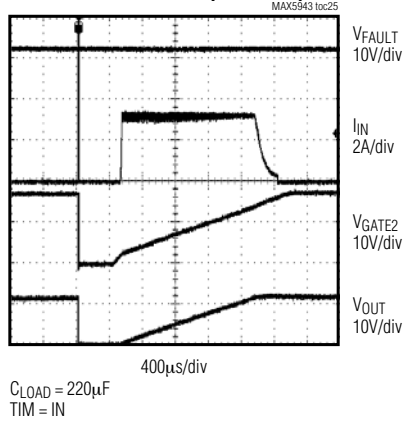

**MAX5943A HOT PLUG-IN LOAD CAPACITANCE  
INTO ACTIVE PORT (CURRENT-LIMIT TIMEOUT)**

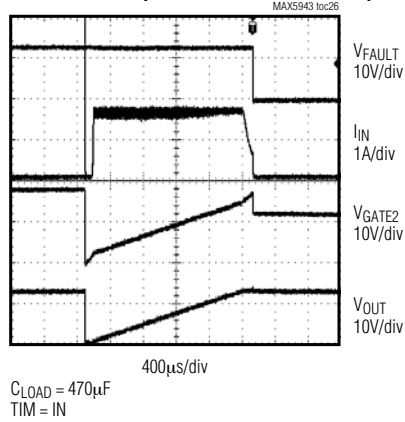



# FireWire Current Limiter and Low-Drop ORing Switch Controller

## Pin Description

MAX5943

PIN	NAME	FUNCTION
1	ON	On/Off-Control Input. ON sets the undervoltage lockout threshold and resets the part after a fault latch. Drive ON high to enable the device. Drive ON low to disable the device. Connect ON to IN for the default undervoltage lockout threshold. Connect a resistor-divider from IN to ON and GND to program the desired undervoltage lockout threshold.
2	$\overline{\text{FAULT}}$	Current-Fault, Active-Low, Open-Drain Output. $\overline{\text{FAULT}}$ asserts and latches low after a current-limit/circuit-breaker fault has exceeded the current-limit/circuit-breaker timeout period (see the <i>FAULT</i> section).
3	TIM	Current-Limit/Circuit-Breaker Timeout Adjustment Input. Connect TIM to IN for the default timeout period or connect a resistor from TIM to GND to program the current-limit/circuit-breaker timeout period.
4	ILIM	Current-Limit/Circuit-Breaker Threshold Input. Leave ILIM open for a 40mV circuit-breaker threshold, connect to GND for a 50mV circuit-breaker threshold, or connect to IN for a 60mV circuit-breaker threshold (see the <i>Current Limiting</i> section).
5	LATCH	Latch or Autoretry Fault Management Selection Input. Connect LATCH to IN to select latch-off mode after a current-limit/circuit-breaker timeout. Connect LATCH to GND for autorestart mode after a current-limit/circuit-breaker timeout.
6	OR_ADJ	ORing Switch Turn-On Current Threshold Adjustment Input. Select one of three ORing switch turn-on threshold settings: connect OR_ADJ to GND, connect OR_ADJ to IN, or leave OR_ADJ floating (see the <i>Power-Supply ORing</i> section).
7, 10, 13	N.C.	No Connection. Not internally connected.
8	ONQ1	ORing Switch Manual Turn-On Input. Drive ONQ1 low to enable power-supply ORing. Drive ONQ1 high to set GATE1 high to allow reverse current flow. ONQ1 is disabled when $V_{IN}$ is below the UVLO threshold, $V_{ON}$ is below the $V_{ON\_REF}$ threshold, and after a current/circuit-breaker fault.
9	GND	Ground
11	OUT	Output Voltage Sense. Connect to the output.
12	GATE2	Current-Limiter Switch Gate Drive Output. Connect GATE2 to the gate of the 2nd n-channel MOSFET. GATE2 is a charge pump with a 45 $\mu$ A pullup current to 5.5V (typ) above OUT when active (see the <i>Typical Operating Circuit</i> ).
14	GATE1	ORing Switch Gate-Drive Output. Connect GATE1 to the gate of the 1st n-channel MOSFET. GATE1 is a charge pump with a 45 $\mu$ A pullup current to 5.5V (typ) above SENSE when active (see the <i>Typical Operating Circuit</i> ).
15	SENSE	Current-Sense Negative Input. Connect a current-sense resistor, $R_{SENSE}$ , from IN to SENSE (see the <i>Typical Operating Circuit</i> ).
16	IN	Input Power and Current-Sense Positive Input. Connect IN to the positive terminal of the current-sense resistor and to the power source (see the <i>Typical Operating Circuit</i> ).

# FireWire Current Limiter and Low-Drop ORing Switch Controller

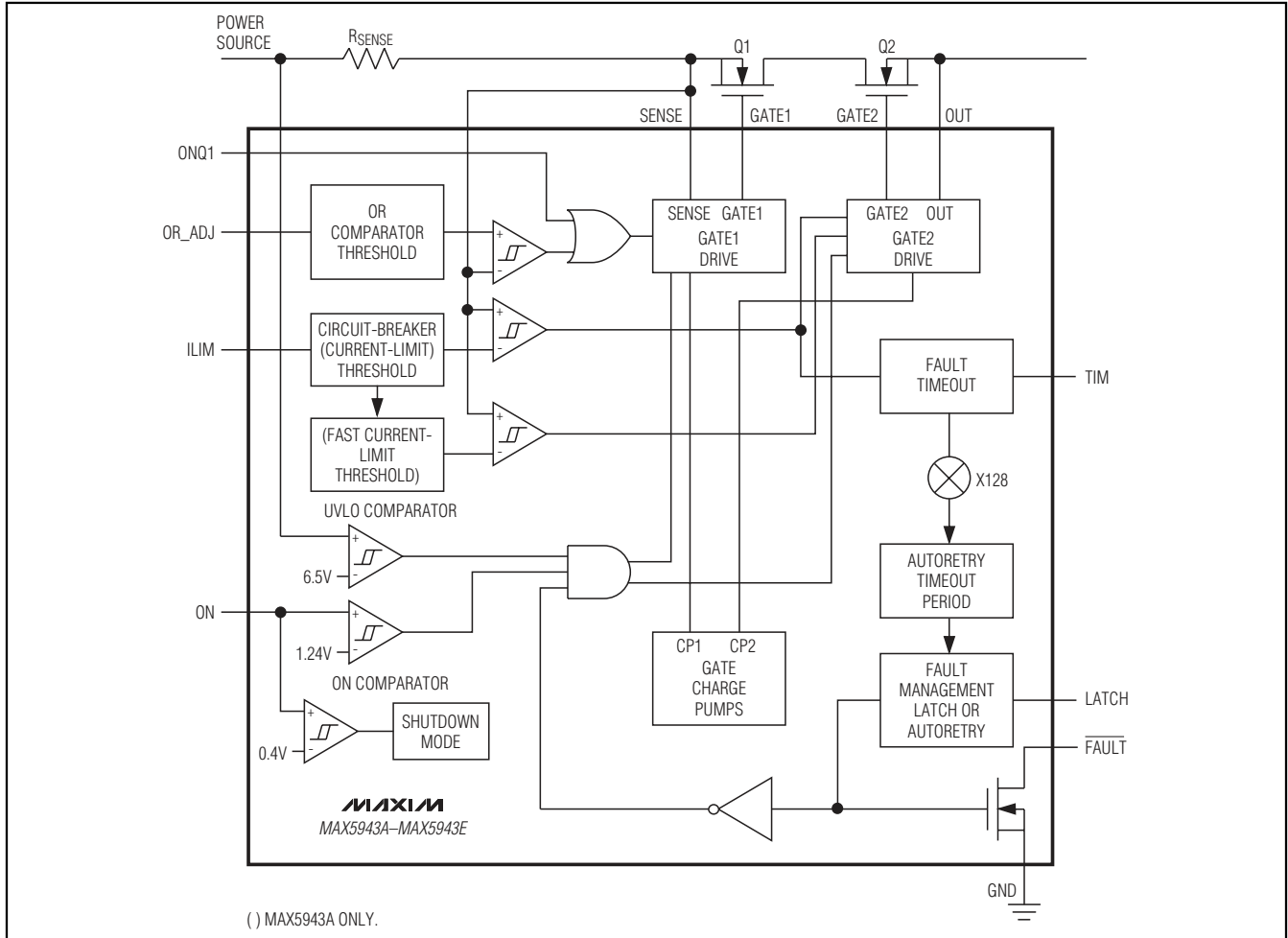

Figure 1. MAX5943 Functional Diagram

## Detailed Description

The MAX5943 performs hot-swapping, power-supply ORing, and current limiting for FireWire power-supply applications. The MAX5943 incorporates two MOSFET drivers (GATE1 and GATE2) to control two external n-channel power MOSFETs to perform low-voltage-drop power-supply ORing (GATE1) and hot swapping and current limiting (GATE2) from the input power supply to the load. A sense resistor provides accurate current-limiting/circuit-breaker function. GATE1 and GATE2 provide true load disconnect to prevent current flowing from either direction between IN and OUT.

The MAX5943 remains in low-current shutdown mode when  $V_{ON}$  is below the 0.4V threshold. Low-current shutdown mode disables the MAX5943, resulting in less than 10 $\mu$ A supply current. Shutdown places all

logic inputs in a high-impedance state allowing the inputs to be connected to IN without drawing additional current from the supply.

When the input supply voltage ( $V_{IN}$ ) is above 7.5V and  $V_{ON}$  is above the  $V_{ON\_REF}$  threshold, the MAX5943 turns on, sourcing 45 $\mu$ A current from GATE2 (current regulation) to enhance Q2 slowly. For the MAX5943A, if the voltage across the current-sense resistor,  $V_{IS}$ , is greater than the programmed current-limit threshold, the MAX5943A regulates the GATE2 voltage to limit the load current at the current-limit level so that  $V_{IS}$  is equal to  $V_{TH}$ . In normal operation,  $V_{IS}$  drops below  $V_{TH}$  and GATE2 rises to approximately 5.5V above OUT. Since the MAX5943B-MAX5943E do not regulate the load current, a capacitor can be added from GATE2 to GND to limit inrush current during startup (see the *Applications Information* section).

# FireWire Current Limiter and Low-Drop ORing Switch Controller

MAX5943

The MAX5943 current-limit/circuit-breaker timeout is programmable by connecting an external resistor from TIM to GND. The MAX5943A has a default 2ms current-limit timeout. The MAX5943B, MAX5943C, MAX5943D, and MAX5943E have 0.5ms, 1ms, 2ms, and 4ms default circuit-breaker timeouts, respectively.

GATE1 controls the MAX5943 ORing function. Initially, GATE1 is off (ONQ1 = low) and the load current conducts through the body diode of Q1. GATE1 rises to 5.5V above SENSE when  $V_{IS}$  exceeds  $V_{OR}$ , thereby enhancing Q1 and reducing the voltage drop, power dissipation, and heat generation in the power-supply path. When a voltage greater than  $V_{IN}$  is connected at OUT, the higher voltage source commences, providing current to the load. The MAX5943 rapidly turns off GATE1 upon  $V_{IS}$  falling below  $V_{OR}$  - hysteresis, thus blocking the higher voltage from back-driving  $V_{IN}$ . GATE1 also turns off when the load current drops, causing  $V_{IS}$  to fall below the  $V_{OR}$  hysteresis.

## Current Limiting/Circuit Breaker

### Current Limiting (MAX5943A Only)

The MAX5943A limits the load current by monitoring the voltage across  $R_{SENSE}$  at all times and by regulating the current to the load as necessary to keep  $V_{IS}$  to its programmable current-limit threshold voltage ( $V_{TH}$ ). Set the maximum current limit ( $I_{LIMIT}$ ) by placing the appropriate sense resistor between IN and SENSE, where  $I_{LIMIT} = V_{TH}/R_{SENSE}$ . When the load current is less than  $I_{LIMIT}$ , GATE2 rises to  $V_{G2}$  (5.5V) to fully enhance MOSFET Q2 (see the *Typical Operating Circuit*).

When the load current attempts to draw more than  $I_{LIMIT}$ , the MAX5943A's GATE2 pulldown current ( $I_{G2D}$ ) regulates the current through Q2 causing OUT to act as a constant-current source. The output current is limited to the programmed  $I_{LIMIT}$ . If the current-limit condition persists after the current-limit timeout ( $t_{LIM}$ ) period has expired, GATE2's strong pulldown current ( $I_{G2 OFF}$ ) quickly turns off GATE2 to disconnect the load from the power supply. FAULT then asserts low (Figure 2a). If the current-limit duration is less than  $t_{LIM}$ , GATE2 pulls to  $V_{G2}$  (Figure 2b). During an output short circuit or a gross overload, the load current overshoots and causes  $V_{IS}$  to exceed the fast pulldown current-limit threshold voltage ( $V_{THF}$ ). The MAX5943A responds with much stronger GATE2 pulldown currents ( $I_{G2DP}$  and/or  $I_{G2DF}$ ) to quickly bring the load current back down to the programmed current limit.

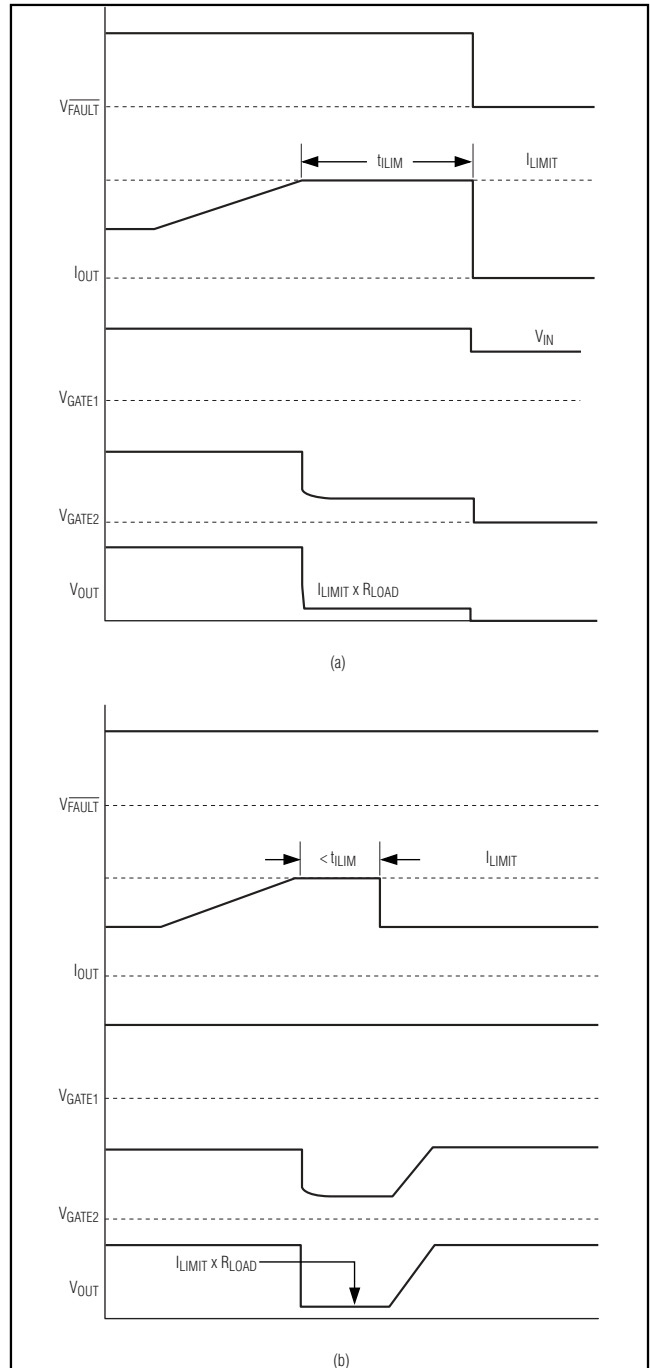

Figure 2. MAX5943A Current-Limit Timing Diagram

# FireWire Current Limiter and Low-Drop ORing Switch Controller

## MAX5943B–MAX5943E Circuit Breaker

The MAX5943B–MAX5943E provide a circuit-breaker function that protects against excessive load currents and short-circuit conditions. The load current is monitored by sensing the voltage across an external sense resistor ( $R_{SENSE}$ ) and disconnects the load from the power source when the voltage across  $R_{SENSE}$ ,  $V_{IS}$ , exceeds the programmed circuit-breaker thresholds ( $V_{TH}$ ) for longer than the circuit-breaker timeout period,  $t_{CB}$ .

Unlike the MAX5943A, when an output short circuit or overcurrent occurs, the MAX5943B–MAX5943E keep GATE2 fully enhanced. The short-circuit current is limited only by the input source impedance,  $R_{SENSE}$ , Q1's  $R_{DS(ON)}$ , Q2's  $R_{DS(ON)}$ , and any parasitic impedance in the power path. If the excessive current condition persists (as indicated by  $V_{IS} > V_{TH}$ ) for longer than  $t_{CB}$ , GATE2 turns off with a strong pulldown ( $I_{G2}$  OFF) to quickly disconnect the power source from the load and  $\overline{FAULT}$  asserts low (Figure 3).

Exercise caution when using the MAX5943B–MAX5943E. Unlike the MAX5943A, the MAX5943B–MAX5943E do not limit the load current during  $t_{CB}$ . High current during  $t_{CB}$  may cause damage to external devices connected in the power path.

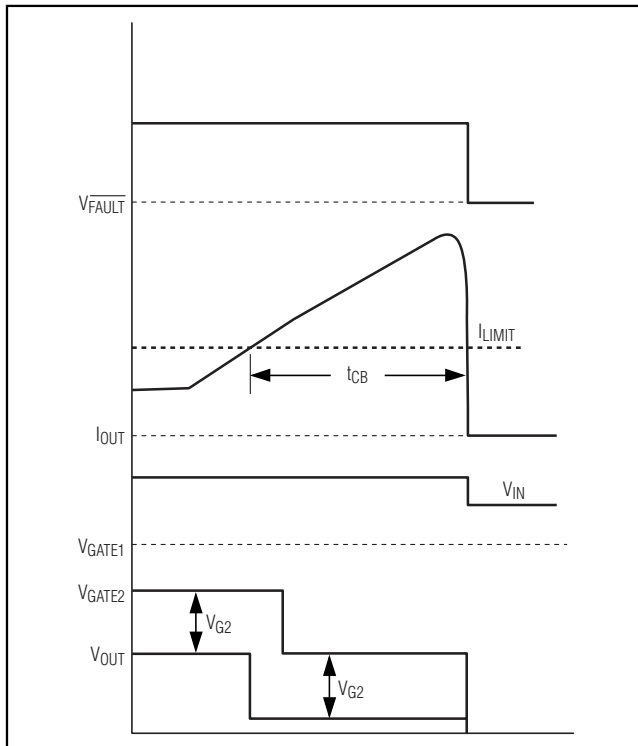

Figure 3. MAX5943B–MAX5943E Circuit-Breaker Timing Diagram

## Current-Limit/Circuit-Breaker Thresholds

The MAX5943 allows three selectable current-limit/circuit-breaker thresholds ( $V_{TH}$ ). Choose the voltage threshold by connecting ILIM to the appropriate level; see Table 1.

Table 1. Current-Limit/Circuit-Breaker Trip Threshold Level

ILIM CONNECTION	$V_{TH}$ (mV)
Open	40
GND	50
IN	60

## Current-Limit/Circuit-Breaker Timeout Period ( $t_{LIM}/t_{CB}$ )

The MAX5943's current-limit/circuit-breaker timeout function disconnects power from the load if the current-limit or circuit-breaker threshold voltage exceeds its maximum limit for a programmable amount of time. Connect TIM to IN for the MAX5943 default timeout periods (see Table 2).

Adjust the fault timeout period ( $t_{LIM}/t_{CB}$ ) by connecting a resistor ( $R_{TIM}$ ) from TIM to GND (see the *Typical Operating Characteristics*). Calculate the fault-limit timeout period using the following equation:

$$t_{LIM} \text{ (ms)} = t_{CB} \text{ (ms)} = 0.25 \times \frac{R_{TIM} \text{ (k}\Omega\text{)}}{K}$$

where  $R_{TIM}$  is in  $k\Omega$ ,  $t_{LIM}/t_{CB}$  is in ms, and  $K = 1$  for MAX5943A,  $K = 32$  for MAX5943B,  $K = 16$  for MAX5943C,  $K = 8$  for MAX5943D, and  $K = 4$  for the MAX5943E.

Table 2. MAX5943 Timeout Periods

PART	DEFAULT TIMEOUT, TIM = IN (ms)	PROGRAMMABLE TIMEOUT RANGE ( $4k\Omega < R_{TIM} < 50k\Omega$ )	MAXIMUM TIMEOUT, TIM = FLOATING (ms)
MAX5943A	2	1.04ms to 11.05ms	175
MAX5943B	0.5	32.5 $\mu$ s to 345 $\mu$ s	4.8
MAX5943C	1	65 $\mu$ s to 690 $\mu$ s	9.6
MAX5943D	2	130 $\mu$ s to 1.38ms	19.2
MAX5943E	4	260 $\mu$ s to 2.76ms	38.4

# FireWire Current Limiter and Low-Drop ORing Switch Controller

**MAX5943**

Timing accuracy is guaranteed for  $R_{TIM}$  ranging from  $4k\Omega$  to  $50k\Omega$ . Large  $R_{TIM}$  values can be used, which reduces timing accuracy. A maximum timeout period is enforced to prevent arbitrarily long operation in current-limit/circuit-breaker conditions.

Long durations in current-limit/circuit-breaker mode may produce excessive heating and electrical stresses in  $R_{SENSE}$ , Q1, Q2, and any other components in the power path. Use component values rated to handle electrical stresses during the timeout period.

### Power-Supply ORing (ONQ1 = Low)

GATE1 controls the MAX5943 ORing function. The MAX5943 accomplishes a very-low-voltage-drop diode ORing function using an n-channel power MOSFET, Q1. Initially, GATE1 is off (ONQ1 = low) and the load current conducts through the body diode of Q1 (Figure 4). GATE1 rises to 5.5V above SENSE when  $V_{IS}$  exceeds  $V_{OR}$ , enhancing Q1. Q1's low  $R_{DS(ON)}$  provides a very-low-voltage drop across its source to drain, reducing voltage drop, power dissipation, and heat generation in the power-supply path created by a traditional diode.

The MAX5943 continuously monitors the load current by the voltage drop,  $V_{IS}$ , across the current-sensing resistor. Q1 turns off rapidly when  $V_{IS}$  decreases below  $V_{OR}$  minus its hysteresis.

Set the MAX5943 ORing threshold ( $V_{OR}$ ) by connecting OR\_ADJ to GND for a 5mV threshold, or to IN for a 10mV threshold, or leave it open for a 7.5mV threshold. Connect ONQ1 to GND for normal ORing function. Drive ONQ1 high to force Q1 on, regardless of the load current condition, as long as the voltages at IN and ON exceed  $V_{UVLO}$  and  $V_{ON\_REF}$ , respectively, and the device is not in a current fault shutdown.

When a higher voltage supply is connected at OUT (Figure 5), the sense voltage drops below the programmable ORing threshold. The MAX5943 immediately turns off Q1, blocking reverse current flow from OUT to IN. The power is then routed from the higher supply input to the load (Figure 6).

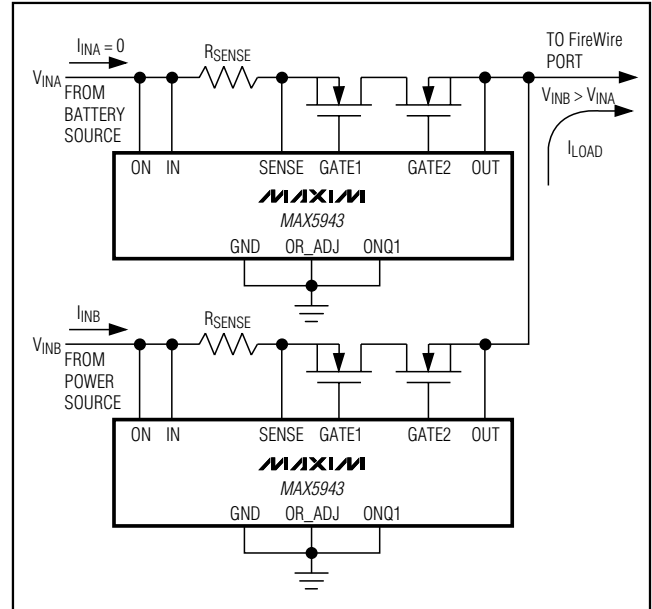

Figure 5. MAX5943 ORing Controller Rerouting Load Current

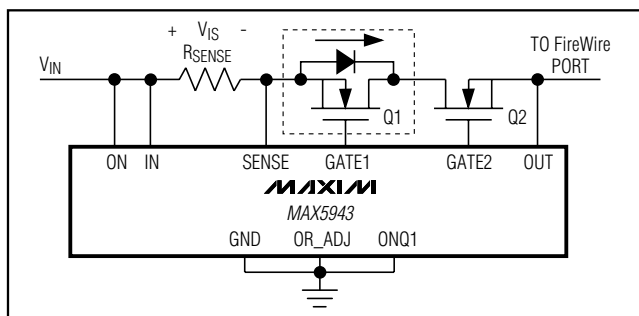

Figure 4. Q1 Current Path During Initial Startup

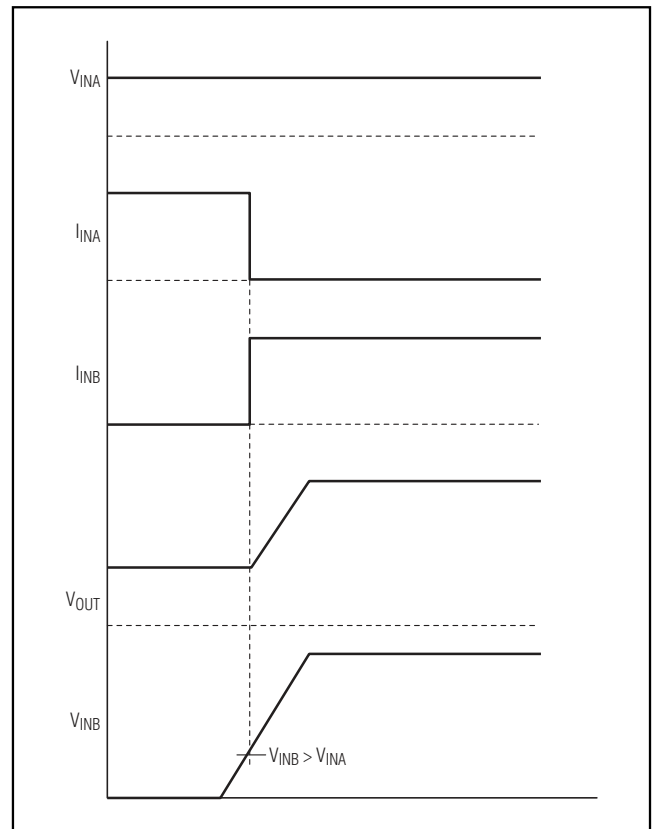

Figure 6. MAX5943 Power Switch Over ORing Timing Diagram

# FireWire Current Limiter and Low-Drop ORing Switch Controller

## Reverse Current Override (ONQ1 = High)

Drive ONQ1 high to disable the power-supply ORing function. Disabling the MAX5943 ORing function allows reverse current flow through the power-supply system. When ONQ1 is high, GATE1 remains fully enhanced as long as  $V_{IN}$  is greater than  $V_{UVLO}$ ,  $V_{ON}$  is above the  $V_{ON\_REF}$  threshold, and the MAX5943 is not in a current-limit or circuit-breaker fault condition. The MAX5943 reverse-current flow feature permits a higher voltage source connected to one port to route power to another port, as long as the voltage at IN remains above the minimum 7.5V operating range (see Figure 7).

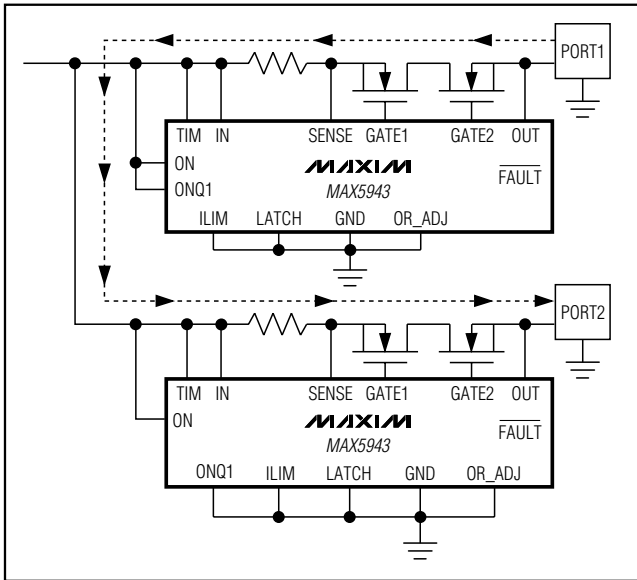

Figure 7. MAX5943 Operating in Reverse-Current Mode (Routing Power from Port 1 to Port 2)

## Undervoltage Lockout

The MAX5943 operates from 7.5V to 37V and has a default 6.5V undervoltage lockout threshold. The external MOSFETs remain off as long as  $V_{IN} > 6.5V$  and  $V_{ON} < V_{ON\_REF}$ . The turn-on threshold is programmable by connecting a resistor-divider at ON. When  $V_{ON} > 1.24V$  and  $V_{IN} > 7.5V$ , GATE2 is enhanced to 5.5V, with respect to OUT and the MAX5943 goes into normal operation.

Program the MAX5943's turn-on voltage using the following formula:

$$R1 = \left( \frac{V_{TURN\_ON}}{1.24} - 1 \right) \times R2$$

where  $V_{TURN\_ON}$  is the desired turn-on voltage of the MAX5943. Choose an  $R2$  value in the 1k $\Omega$  range to minimize error due to the ON bias current.

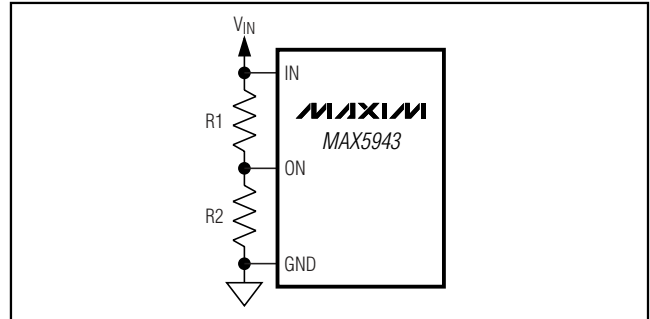

Figure 8. Setting the MAX5943 Turn-On Voltage

When operating the MAX5943, ON must remain above its 1.24V threshold. If  $V_{ON}$  falls below its 1.24V threshold, the power-supply MOSFETs (Q1 and Q2) turn off immediately (less than 1 $\mu$ s). This allows the power supply to disconnect in the event of a fault condition detected by the system, such as shorting of the output to a different power-supply voltage or a FireWire signal pin. If possible transient conditions exist at the main power-supply line (IN), place an RC filter at ON to reject transient voltage dips and to prevent unnecessary power-supply interruptions.

The MAX5943 remains in low-current shutdown mode when  $V_{ON}$  is below the 0.4V threshold. Low-current shutdown mode disables the MAX5943 resulting in less than 10 $\mu$ A supply current. Shutdown places all logic inputs in a high-impedance state allowing the inputs to be connected to IN without drawing additional current from the supply. An internal delay,  $t_{SD}$ , allows Q1 and Q2 to be turned off before the MAX5943 enters low-current shutdown mode.

## Fault Status Output (FAULT)

$\overline{FAULT}$  is a high-voltage open-drain output that pulls low when a current-limit/circuit-breaker fault shutdown has occurred.  $\overline{FAULT}$  remains low until the next startup cycle.

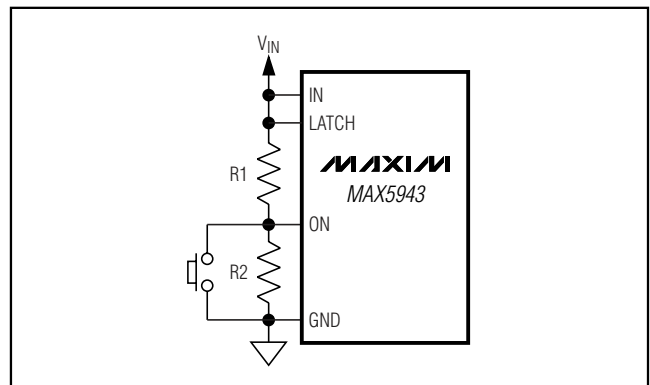

Figure 9. Resetting MAX5943 After a Latched Fault Condition

# FireWire Current Limiter and Low-Drop ORing Switch Controller

## Fault Management

The MAX5943 offers either latch or autoretry fault management configurable by the LATCH input. Connect LATCH to IN for latch fault management or connect LATCH to GND for autoretry fault management. In latch fault management, FAULT latches low, GATE1 and GATE2 latch off indefinitely. Cycle ON low and then high to unlatch and restart the MAX5943. However, the MAX5943 will not enter a startup cycle until tOFF has expired. Figure 9 illustrates a way to reset the MAX5943 after a fault using a pushbutton switch.

In autoretry fault management, the MAX5943\_attempt to restart after a tOFF of 128 x tLIM (or 128 x tCB) limiting the duty cycle of the MOSFETs to 1/129 under continuous fault conditions. FAULT deasserts every time a restart attempt is made.

## Applications Information

### Startup Consideration

#### MAX5943A

During startup, a large capacitor at OUT may result in a charging current equivalent to the current limit. Choose a current-limit timeout that will allow a successful startup. The timeout can be approximated using the following equation:

$$t_{LIM} > \frac{C_{OUT} \times V_{IN}}{I_{LIMIT} - I_{LOAD}}$$

where I<sub>LIMIT</sub> is the programmed current limit, C<sub>OUT</sub> is the capacitor at OUT, V<sub>IN</sub> is the supply voltage, and I<sub>LOAD</sub> is the load current during startup. With IN = 12V, C<sub>OUT</sub> = 330μF, I<sub>LIMIT</sub> = 1.5A, and I<sub>LOAD</sub> = 0, the MAX5943 commences by charging the output capacitor with 1.5A for approximately 2.7ms. Therefore, the MAX5943A current-limit timeout period (t<sub>LIM</sub>) should be greater than 2.7ms for a successful startup. Otherwise, the MAX5943A powers up in fault management mode by exceeding the current-limit timeout period.

#### MAX5943B–MAX5943E

The MAX5943B–MAX5943E do not control the inrush current during startup. Inrush current control can be implemented by placing a resistor and capacitor at GATE2 (Figure 10) to slowly ramp up the gate voltage, thus limiting the inrush current. The inrush current can be approximated using the following formula:

$$I_{INRUSH} = \frac{C_{OUT}}{C_{GATE2}} \times I_{G2U} + I_{LOAD}$$

Where I<sub>G2U</sub> is GATE2's 45μA sourcing current and I<sub>LOAD</sub> is the load current at startup.

To prevent the MAX5943B–MAX5943E from starting up in a fault condition set:

$$I_{INRUSH} < \frac{V_{TH}}{R_{SENSE}}$$

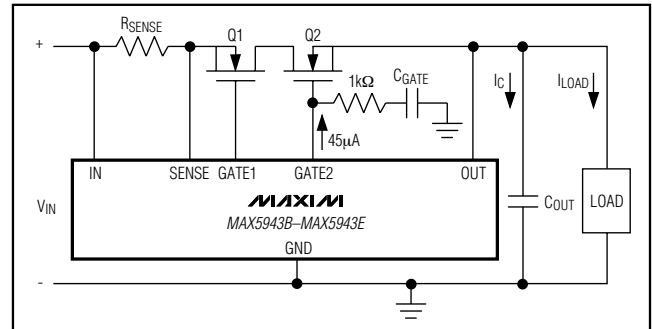

Figure 10. Controlling the MAX5943B–MAX5943E Inrush Current

### Optimizing for Short-Circuit Conditions

#### Choosing RSENSE

Select a sense resistor that causes the circuit-breaker voltage drop at a current-limit/circuit-breaker level above the maximum normal operating current. Typically, set the overload current at 1.2 to 1.5 times the full load current.

Choose the sense-resistor power rating to accommodate an overcurrent condition:

$$P_{RSENSE} = I_{LIMIT}^2 \times R_{SENSE}$$

where P<sub>RSENSE</sub> is the power dissipated across R<sub>SENSE</sub> during a current-limit/circuit-breaker fault.

Under short-circuit conditions, it is imperative that the appropriate sense resistor is utilized. Operating the MAX5943B–MAX5943E at high input voltages can cause very large currents during the circuit-breaker timeout period. The peak current will be limited by the saturation current of Q2 or the series resistance in the power path (R<sub>TOTAL</sub>).

Using a 30mΩ on-resistance MOSFET at GATE1 and GATE2 and a 30mΩ sense resistor results in a short-circuit current approximately equal to:

$$I_{SC} = V_{IN}/R_{TOTAL}$$

where:

$$\begin{aligned} R_{TOTAL} &= R_{SENSE} + 2 \times (R_{ON}) \\ &= 30m\Omega + 2 \times (30m\Omega) = 90m\Omega \end{aligned}$$

For example, an input voltage of 20V produces a current at approximately 222A (or I<sub>SAT</sub> of Q2, whichever is less) in the power path for the circuit-breaker timeout period. Choose an R<sub>SENSE</sub> capable of handling the high power dissipation during a short-circuit event.

# FireWire Current Limiter and Low-Drop ORing Switch Controller

## MOSFET Selection

Select external MOSFETs according to the application current level. The MOSFETs' on-resistance ( $R_{DS(ON)}$ ) should be chosen low enough to have minimum voltage drop at full load to limit the MOSFET power dissipation. High  $R_{DS(ON)}$  also causes large output ripple if there is a pulsating load. Determine the device power rating to accommodate startup, a short-circuit condition, and when the device is in autoretry mode.

During normal operation, the external MOSFETs dissipate little power. The power dissipated in normal operation is:

$$P = I_{LOAD}^2 \times R_{DS(ON)}$$

The most power dissipation occurs during a short-circuit event, resulting in high power dissipated in Q2 (Figure 11) during the timeout period for the MAX5943A, where the power dissipated across Q2 is:

$$P_{Q2} = (V_{IN} - V_{IS} - V_{Q1}) \times I_{LIMIT}$$

For the MAX5943B–MAX5943E, a short-circuit event results in high power dissipated in both Q1 and Q2 during the timeout period (Figure 13) where the total power dissipated in either MOSFET is:

$$P = I_{SC}^2 \times R_{DS(ON)}$$

where:

$$I_{SC} = V_{IN}/R_{EQ}$$

and

$$R_{EQ} = R_{SENSE} + R_{DS(ON1)} + R_{DS(ON2)}$$

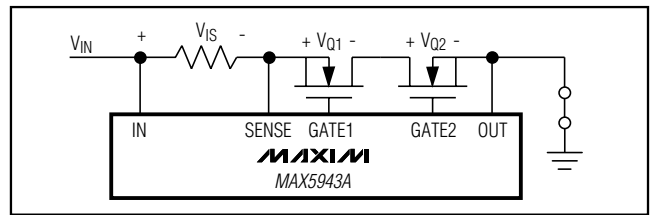

Figure 11. Power Dissipated Across MOSFETs During a Short-Circuit Fault for MAX5943A

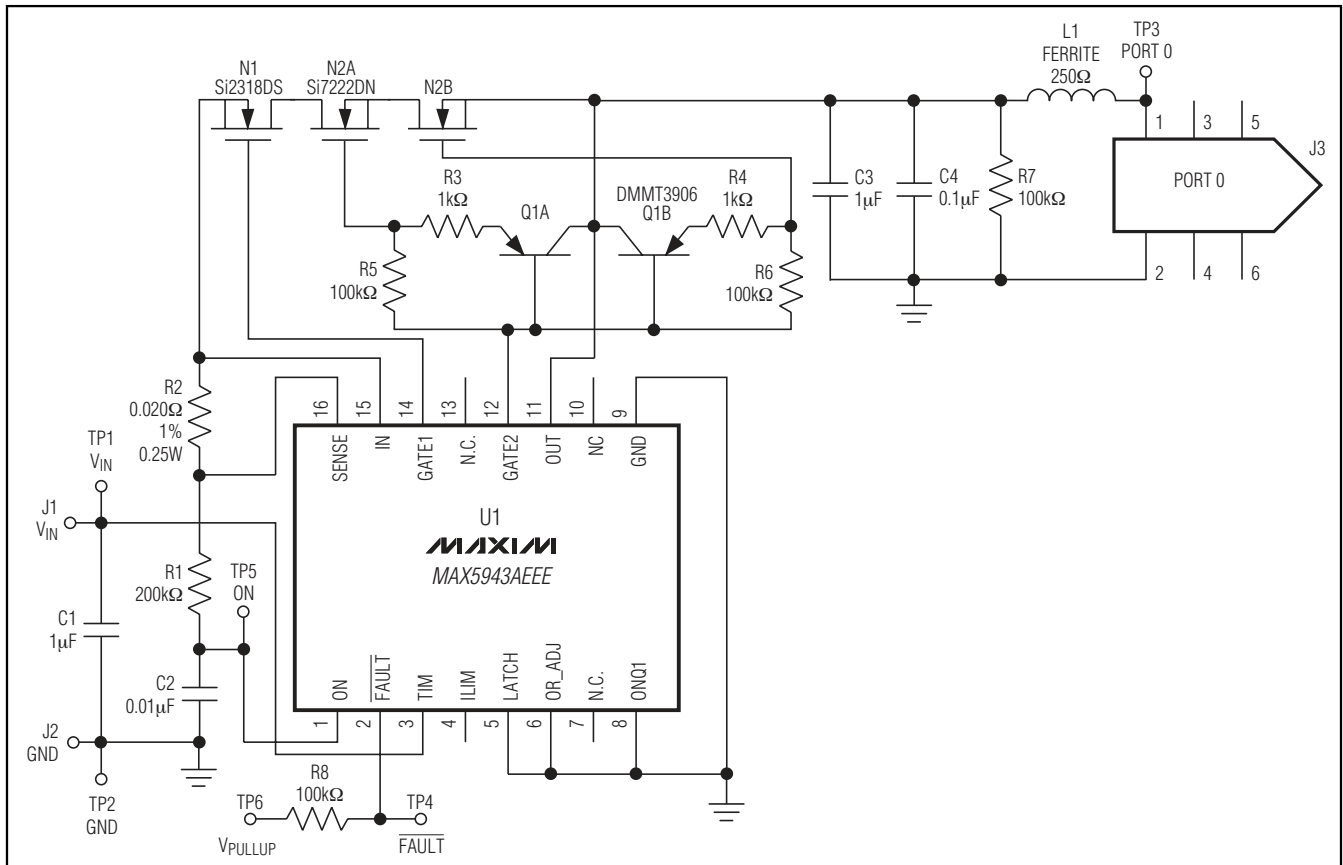

Figure 12. UL-Recognized Single-Port FireWire Protective Circuit



# FireWire Current Limiter and Low-Drop ORing Switch Controller

The programmable timeout of the MAX5943 allows the use of MOSFETs with low power ratings. A MOSFET typically withstands single-shot pulses with higher dissipation than the specified package rating.

A single-port FireWire protective circuit employing the MAX5943A has been UL recognized as a result of extensive safety testing by Underwriters Laboratories. It is the circuits themselves, not any individual component

thereof, that are UL recognized. The circuit is further described in Application Note 3984—*UL Recognized, IEEE 1394 Single- and Dual-Port FireWire Protective Circuits* available at [www.maxim-ic.com/appnotes.cfm/appnote\\_number/3984](http://www.maxim-ic.com/appnotes.cfm/appnote_number/3984).

The circuit provides:

- 2.5A (adjustable) current limiting to the load at initial connection or in overload fault condition
- 2ms (adjustable) current-limit timeout before load disconnect for excessive load current
- Automatic-restart attempts after a fault shutdown condition
- <0.8% current-limited duty cycle in continuous fault condition
- 6.5V undervoltage shutdown protection
- Low-drop ORing in multiple power-source applications, and
- Fault reporting

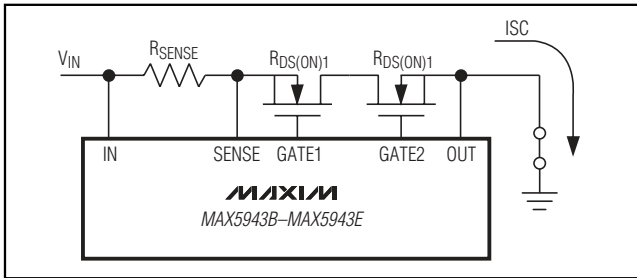

Figure 13. Power Dissipated Across MOSFETs During a Short-Circuit Fault for MAX5943B-MAX5943E

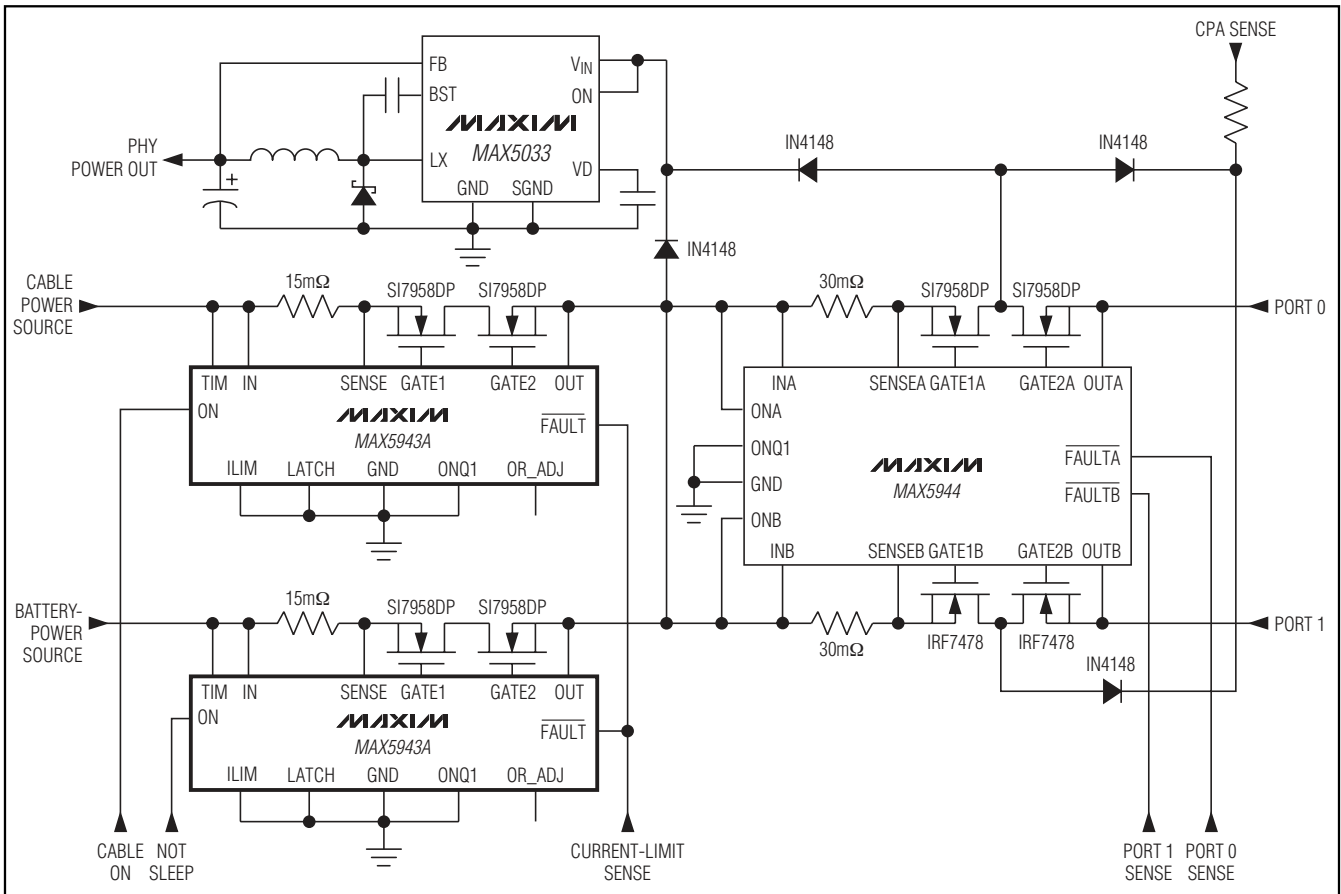

Figure 14. Two-Port FireWire Power Provider Using MAX5943A and MAX5944

# FireWire Current Limiter and Low-Drop ORing Switch Controller

## FireWire Power Management

The MAX5943 serves to regulate and protect FireWire power over a system interface. The MAX5943 programmable features make it suitable for both power provider and power receiver applications. Figure 14 shows a high-end two-port FireWire power management system using two MAX5943As and a dual-channel MAX5944 FireWire current-limiting IC.

## Transient Protection

If IN or OUT experiences a fast voltage transient, the drain-to-gate parasitic capacitance of Q1 and/or Q2 may be sufficient to briefly enhance one of the transistors, allowing current glitch. If the circuit is subjected to large transients, connect capacitors from the gate to source across the appropriate MOSFET, preventing the parasitic capacitance from turning on the device.

**Caution:** The additional gate-to-source capacitance causes the turn-off time of the MOSFETs to increase due to the additional charge of the capacitor. Use the minimum capacitor value to prevent currents from flowing in hot-plug situations.

## Typical Operating Circuit

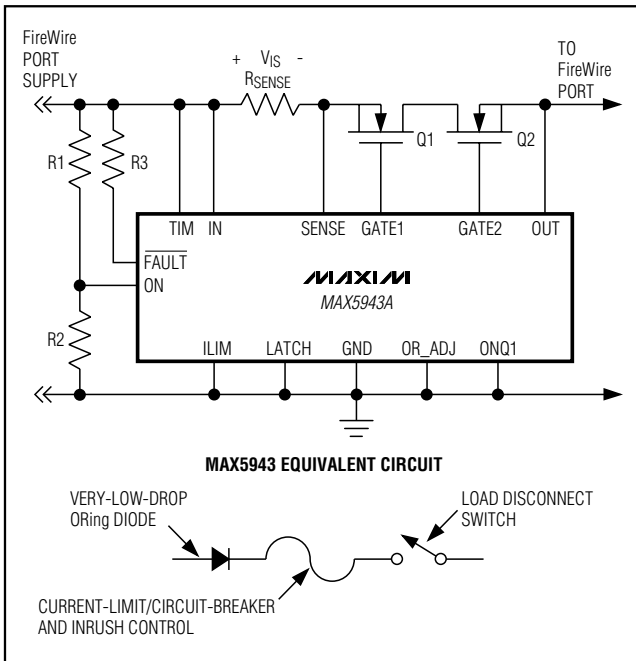

## Typical Application Circuit

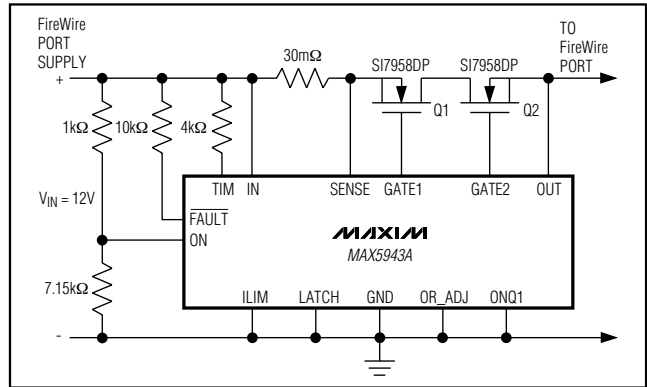

## Selector Guide

PART	CURRENT LIMITER/CIRCUIT BREAKER	DEFAULT TIMEOUT (ms)	PROGRAMMABLE TIMEOUT RANGE
MAX5943A	Current limit	2	1.04ms to 11.05ms
MAX5943B	Circuit breaker	0.5	32.5μs to 345μs
MAX5943C	Circuit breaker	1	65μs to 690μs
MAX5943D	Circuit breaker	2	130μs to 1.38ms
MAX5943E	Circuit breaker	4	260μs to 2.76ms

## Chip Information

TRANSISTOR COUNT: 2324

PROCESS: BiCMOS

# FireWire Current Limiter and Low-Drop ORing Switch Controller

## Package Information

(The package drawing(s) in this data sheet may not reflect the most current specifications. For the latest package outline information go to [www.maxim-ic.com/packages](http://www.maxim-ic.com/packages).)

MAX5943

QSOP-EPS

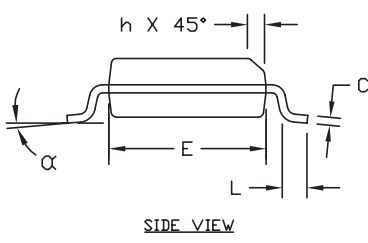
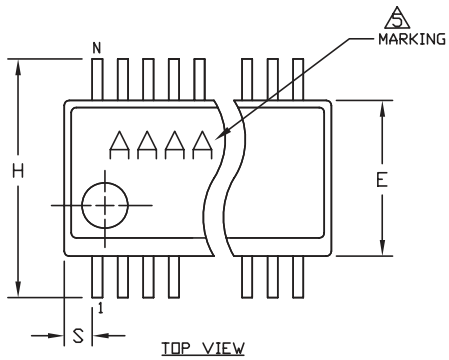

DIM	INCHES		MILLIMETERS	
	MIN	MAX	MIN	MAX
A	.053	.069	1.35	1.75
A1	.004	.010	.102	.254
A2	.049	.065	1.245	1.651
B	.008	.012	0.20	0.30
C	.0075	.0098	0.191	0.249
D	SEE VARIATIONS			
E	.150	.157	3.81	3.99
e	.025 BSC		0.635 BSC	
H	.230	.244	5.84	6.20
h	.010	.016	0.25	0.41
L	.016	.035	0.41	0.89
N	SEE VARIATIONS			
alpha	0°	8°	0°	8°

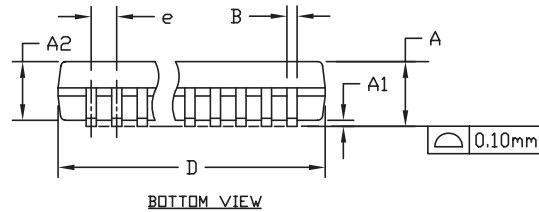

VARIATIONS:

DIM	INCHES		MILLIMETERS		N	PKG CODES
	MIN.	MAX.	MIN.	MAX.		
D	.189	.196	4.80	4.98	16	E16-1, E16M-1, E16-3F, E16-4, E16-5, E16-6, E16-8F
S	.0020	.0070	0.05	0.18		
D	.337	.344	8.56	8.74	20	E20-1, E20-2
S	.0500	.0550	1.270	1.397		
D	.337	.344	8.56	8.74	24	E24-1, E24-2, E24-3F
S	.0250	.0300	0.635	0.762		
D	.386	.393	9.80	9.98	28	E28-1, E28M-1, E28-2
S	.0250	.0300	0.635	0.762		

NOTES:

1. D & E DO NOT INCLUDE MOLD FLASH OR PROTRUSIONS.
2. MOLD FLASH OR PROTRUSIONS NOT TO EXCEED .006" PER SIDE.
3. CONTROLLING DIMENSIONS: INCHES.
4. MEETS JEDEC MO137.
5. MARKING SHOWN IS FOR PKG. ORIENTATION ONLY.
6. ALL DIMENSIONS APPLY TO BOTH LEADED (-) AND PkFREE (+) PKG. CODES.

-DRAWING NOT TO SCALE-

TITLE:  
PACKAGE OUTLINE  
QSOP .150", .025" LEAD PITCH

APPROVAL	DOCUMENT CONTROL NO. 21-0055	REV. G	1/1
----------	---------------------------------	-----------	-----

# FireWire Current Limiter and Low-Drop ORing Switch Controller

## Revision History

REVISION NUMBER	REVISION DATE	DESCRIPTION	PAGES CHANGED
0	8/04	Initial release	—
1	1/05	Corrected Table 2 and Figures 10, 11, and 12	12, 15, 16, 17
2	10/07	Added FireWire/IEEE and UL information, inserted new Figure 12, and updated Package Outline	1, 16, 17, 18, 20

Maxim cannot assume responsibility for use of any circuitry other than circuitry entirely embodied in a Maxim product. No circuit patent licenses are implied. Maxim reserves the right to change the circuitry and specifications without notice at any time.

20 \_\_\_\_\_ **Maxim Integrated Products, 120 San Gabriel Drive, Sunnyvale, CA 94086 408-737-7600**