

RF-Hardened, Low-Noise Microphone with Bottom Port and Analog Output

GENERAL DESCRIPTION

The ICS-40180* is an analog MEMS microphone with high SNR and enhanced RF immunity. The ICS-40180 includes a MEMS microphone element, an impedance converter, and an output amplifier.

Other high-performance specifications include a linear response up to 124 dB SPL, tight ± 1 dB sensitivity tolerance, and enhanced immunity to both radiated and conducted RF interference.

The ICS-40180 is available in a small, 3.5 mm \times 2.65 mm \times 0.98 mm, surface-mount package.

**Protected by U.S. Patents 7,449,356; 7,825,484; 7,885,423; and 7,961,897. Other patents are pending.*

APPLICATIONS

- Smartphones
- Tablet Computers
- Wearable Devices
- Still and Video Cameras
- Bluetooth Headsets
- Notebook PCs
- Security and Surveillance

FEATURES

- High 65 dBA SNR
- -38 dBV Sensitivity
- ± 1 dB Sensitivity Tolerance
- Non-Inverted Signal Output
- Extended Frequency Response from 60 Hz to 20 kHz
- Enhanced RF Immunity
- 124 dB SPL Acoustic Overload Point
- Low Current Consumption: 190 μ A
- Single-Ended Analog Output
- High -78 dBV PSR
- 3.5 \times 2.65 \times 0.98 mm Surface-Mount Package
- Compatible with Sn/Pb and Pb-Free Solder Processes
- RoHS/WEEE Compliant

FUNCTIONAL BLOCK DIAGRAM

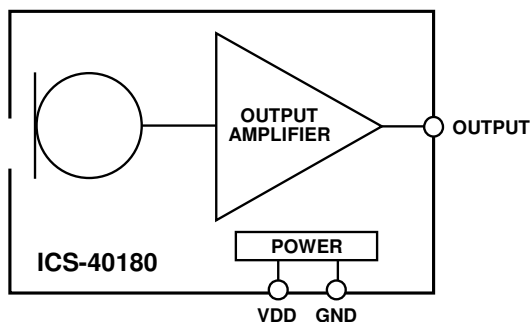

ORDERING INFORMATION

| PART | TEMP RANGE | PACKAGING |
|-----------------|--|-------------------|
| ICS-40180 | -40°C to $+85^{\circ}\text{C}$ | 13" Tape and Reel |
| EV_IC3-40180-FX | — | |

TABLE OF CONTENTS

| | |
|--|----|
| General Description | 1 |
| Applications | 1 |
| Features | 1 |
| Functional Block Diagram | 1 |
| Ordering Information..... | 1 |
| Table of Contents..... | 2 |
| Specifications | 3 |
| Table 1. Electrical Characteristics | 3 |
| Absolute Maximum Ratings..... | 4 |
| Table 2. Absolute Maximum Ratings | 4 |
| ESD Caution | 4 |
| Soldering Profile..... | 5 |
| Table 3. Recommended Soldering Profile*..... | 5 |
| Pin Configuration And Function Descriptions..... | 6 |
| Table 4. Pin Function Descriptions..... | 6 |
| Typical Performance Characteristics..... | 7 |
| Applications Information | 8 |
| Codec Connection..... | 8 |
| Supporting Documents | 9 |
| Evaluation Board User Guide..... | 9 |
| Application Notes | 9 |
| PCB Design And Land Pattern Layout | 10 |
| PCB Material And Thickness | 10 |
| Handling Instructions..... | 11 |
| Pick And Place Equipment | 11 |
| Reflow Solder..... | 11 |
| Board Wash..... | 11 |
| Outline Dimensions..... | 12 |
| Ordering Guide | 12 |
| Revision History | 13 |
| Compliance Declaration Disclaimer | 14 |

SPECIFICATIONS

TABLE 1. ELECTRICAL CHARACTERISTICS

T_A = 25°C, V_{DD} = 1.5 to 3.63 V, unless otherwise noted. Typical specifications are not guaranteed.

| PARAMETER | CONDITIONS | MIN | TYP | MAX | UNITS | NOTES |
|-------------------------------------|---|--------------|-------|------|---------|-------|
| PERFORMANCE | | | | | | |
| Directionality | | Omni | | | | |
| Output Polarity | | Non-Inverted | | | | |
| Sensitivity | 1 kHz, 94 dB SPL | -39 | -38 | -37 | dBV | |
| Signal-to-Noise Ratio (SNR) | 20 Hz to 20 kHz, A-weighted | | 65 | | dBA | |
| Equivalent Input Noise (EIN) | 20 Hz to 20 kHz, A-weighted | | 29 | | dBA SPL | |
| Dynamic Range | Derived from EIN and maximum acoustic input | | 95 | | dB | |
| Frequency Response | Low frequency -3 dB point | | 60 | | Hz | 1 |
| | High frequency -3 dB point | | >20 | | kHz | |
| Total Harmonic Distortion (THD) | 105 dB SPL | | 0.3 | 1 | % | |
| Power-Supply Rejection (PSR) | 217 Hz, 100 mVp-p square wave superimposed on V _{DD} = 1.8 V | | -78 | | dBV | |
| Power Supply Rejection Ratio (PSRR) | 1 kHz, 100 mVp-p sine wave superimposed on V _{DD} = 1.8 V | | -46 | | dB | |
| Acoustic Overload Point | 10% THD | | 124 | | dB SPL | |
| POWER SUPPLY | | | | | | |
| Supply Voltage (V _{DD}) | | 1.5 | | 3.63 | V | |
| Supply Current (I _s) | V _{DD} = 1.8 V | | 190 | 240 | μA | |
| | V _{DD} = 3.3 V | | 210 | 260 | μA | |
| OUTPUT CHARACTERISTICS | | | | | | |
| Output Impedance | | | 350 | | Ω | |
| Output DC Offset | | | 0.7 | | V | |
| Maximum Output Voltage | 124 dB SPL input | | 0.398 | | V rms | |
| Noise Floor | 20 Hz to 20 kHz, A-weighted, rms | | -103 | | dBV | |

Note 1: See Figure 3 and Figure 4.

ABSOLUTE MAXIMUM RATINGS

Stress above those listed as Absolute Maximum Ratings may cause permanent damage to the device. These are stress ratings only and functional operation of the device at these conditions is not implied. Exposure to the absolute maximum ratings conditions for extended periods may affect device reliability.

TABLE 2. ABSOLUTE MAXIMUM RATINGS

| PARAMETER | RATING |
|-----------------------------|---|
| Supply Voltage (V_{DD}) | -0.3 V to +3.63 V |
| Sound Pressure Level | 160 dB |
| Mechanical Shock | 10,000 <i>g</i> |
| Vibration | Per MIL-STD-883 Method 2007, Test Condition B |
| Temperature Range | |
| Biased | -40°C to +85°C |
| Storage | -55°C to +150°C |

ESD CAUTION



ESD (electrostatic discharge) sensitive device. Charged devices and circuit boards can discharge without detection. Although this product features patented or proprietary protection circuitry, damage may occur on devices subjected to high energy ESD. Therefore proper ESD precautions should be taken to avoid performance degradation or loss of functionality.

SOLDERING PROFILE

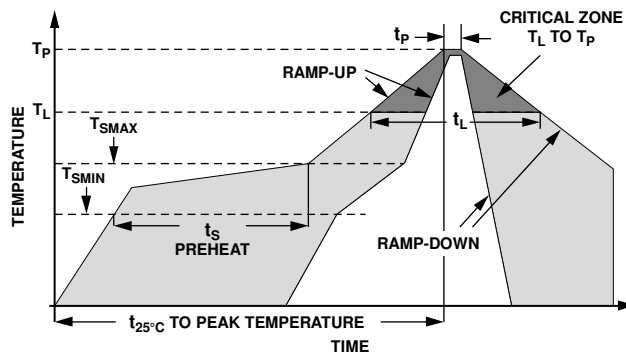

Figure 1. Recommended Soldering Profile Limits

TABLE 3. RECOMMENDED SOLDERING PROFILE*

| PROFILE FEATURE | | Sn63/Pb37 | Pb-Free |
|---|--|------------------|------------------|
| Average Ramp Rate (T_L to T_P) | | 1.25°C/sec max | 1.25°C/sec max |
| Preheat | Minimum Temperature (T_{SMIN}) | 100°C | 100°C |
| | Minimum Temperature (T_{SMIN}) | 150°C | 200°C |
| | Time (T_{SMIN} to T_{SMAX}), t_S | 60 sec to 75 sec | 60 sec to 75 sec |
| Ramp-Up Rate (T_{SMAX} to T_L) | | 1.25°C/sec | 1.25°C/sec |
| Time Maintained Above Liquidous (t_L) | | 45 sec to 75 sec | ~50 sec |
| Liquidous Temperature (T_L) | | 183°C | 217°C |
| Peak Temperature (T_P) | | 215°C +3°C/-3°C | 260°C +0°C/-5°C |
| Time Within +5°C of Actual Peak Temperature (t_P) | | 20 sec to 30 sec | 20 sec to 30 sec |
| Ramp-Down Rate | | 3°C/sec max | 3°C/sec max |
| Time +25°C ($t_{25^\circ C}$) to Peak Temperature | | 5 min max | 5 min max |

**The reflow profile in Table 3 is recommended for board manufacturing with InvenSense MEMS microphones. All microphones are also compatible with the J-STD-020 profile*

PIN CONFIGURATION AND FUNCTION DESCRIPTIONS

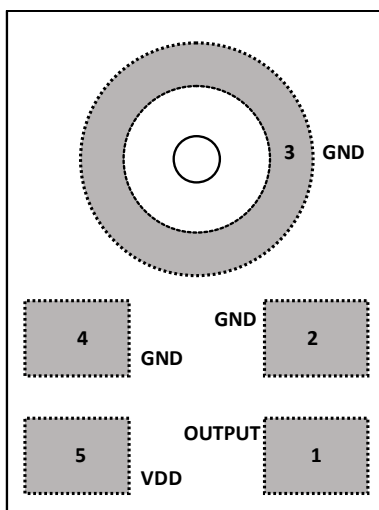

**Figure 2. Pin Configuration
Top View (Terminal Side Down)
Not to Scale**

TABLE 4. PIN FUNCTION DESCRIPTIONS

| PIN | NAME | FUNCTION |
|-----|--------|----------------------|
| 1 | OUTPUT | Analog Output Signal |
| 2 | GND | Ground |
| 3 | GND | Ground |
| 4 | GND | Ground |
| 5 | VDD | Power Supply |

TYPICAL PERFORMANCE CHARACTERISTICS

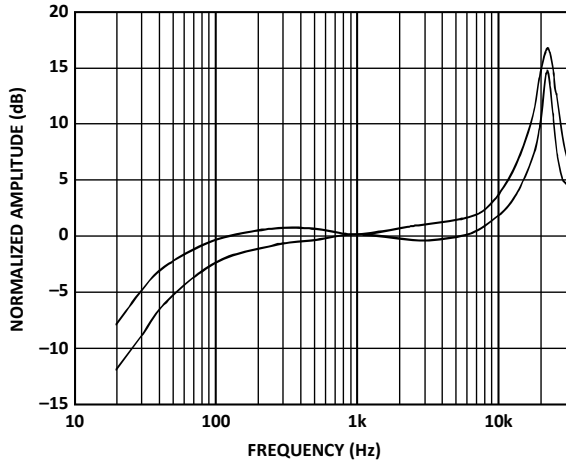

Figure 3. Frequency Response Mask

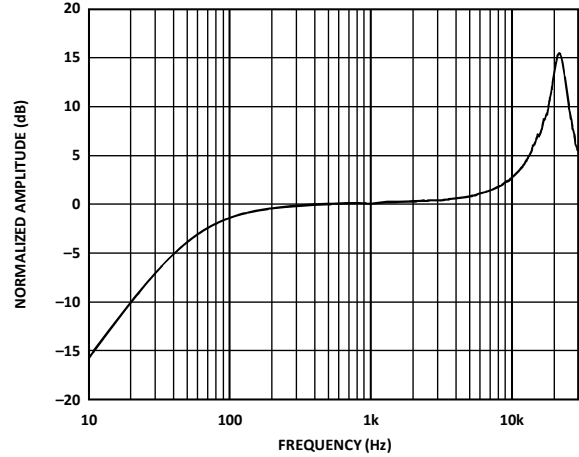

Figure 4. Typical Frequency Response (Measured)

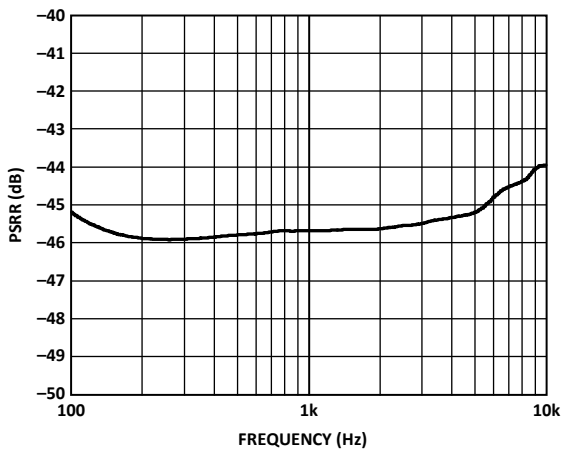

Figure 5. PSR vs. Frequency, 100 mV p-p Swept Sine Wave

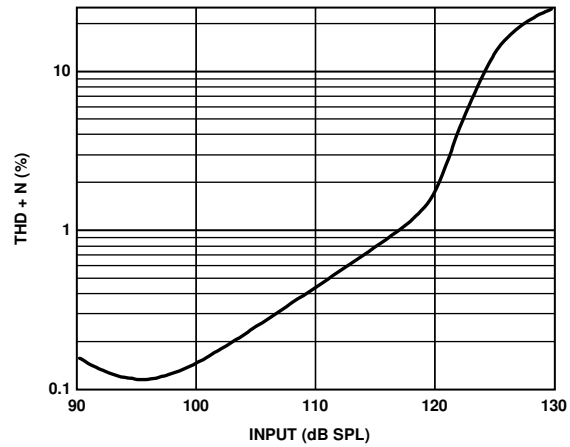

Figure 6. Total Harmonic Distortion + Noise (THD+N) vs. Input SPL

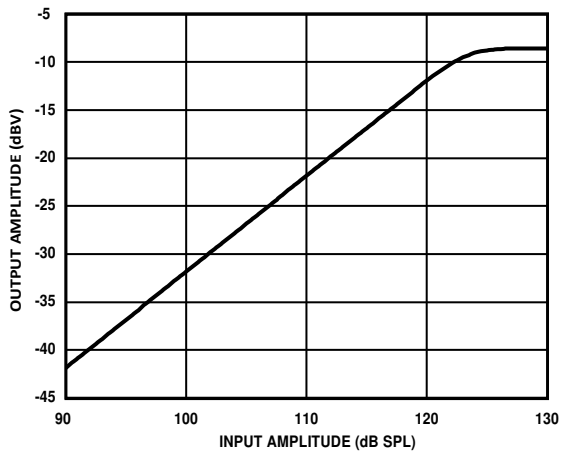

Figure 7. Linearity

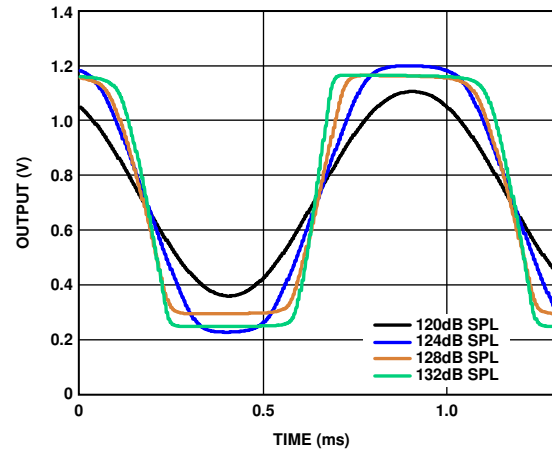

Figure 8. Clipping Characteristics

APPLICATIONS INFORMATION

CODEC CONNECTION

The ICS-40180 output can be connected to a dedicated codec microphone input (see Figure 9) or to a high input impedance gain stage. A 0.1 μF ceramic capacitor placed close to the ICS-40180 supply pin is used for testing and is recommended to adequately decouple the microphone from noise on the power supply. A DC blocking capacitor is required at the output of the microphone. This capacitor creates a high-pass filter with a corner frequency at

$$f_c = 1/(2\pi \times C \times R)$$

where *R* is the input impedance of the codec.

A minimum value of 2.2 μF is recommended in Figure 9 because the input impedance of some codecs can be as low as 2 kΩ at their highest PGA gain setting, which results in a high-pass filter corner frequency at 37 Hz. Figure 10 shows the ICS-40180 connected to an op amp configured as a noninverting preamplifier.

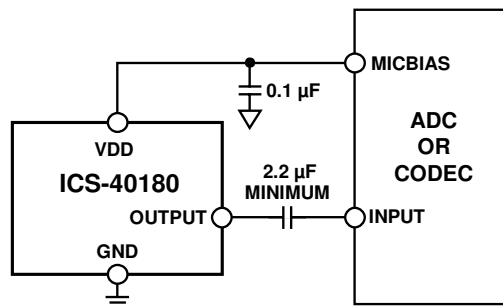

Figure 9. ICS-40180 Connected to a Codec

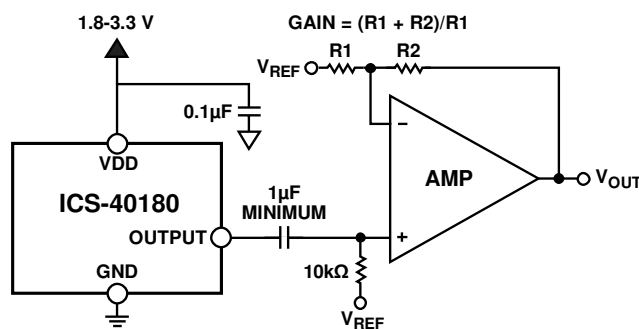

Figure 10. ICS-40180 Connected to an Op Amp

SUPPORTING DOCUMENTS

For additional information, see the following documents.

EVALUATION BOARD USER GUIDE

UG-325, *Analog Output MEMS Microphone Flex Evaluation Board*

APPLICATION NOTES

AN-100, *MEMS Microphone Handling and Assembly Guide*

AN-1003, *Recommendations for Mounting and Connecting the InvenSense Bottom-Ported MEMS Microphones*

AN-1112, *Microphone Specifications Explained*

AN-1124, *Recommendations for Sealing InvenSense Bottom-Port MEMS Microphones from Dust and Liquid Ingress*

AN-1140, *Microphone Array Beamforming*

AN-1165, *Op Amps for Microphone Preamp Circuits*

AN-1181, *Using a MEMS Microphone in a 2-Wire Microphone Circuit*

PCB DESIGN AND LAND PATTERN LAYOUT

Below is the lay out the PCB land pattern for the ICS-40180, at a 1:1 ratio to the solder pads on the microphone package, (see Figure 11.) Take care to avoid applying solder paste to the sound hole in the PCB. Figure 12 shows a suggested solder-paste stencil pattern layout. The response of the ICS-40180 is not affected by the PCB hole size, as long as the hole is not smaller than the sound port of the microphone (0.25 mm, or 0.01 inch, in diameter). A 0.5 mm to 1 mm (0.020 inch to 0.040 inch) diameter for the hole is recommended.

Align the hole in the microphone package with the hole in the PCB. The exact degree of the alignment does not affect the performance of the microphone as long as the holes are not partially or completely blocked.

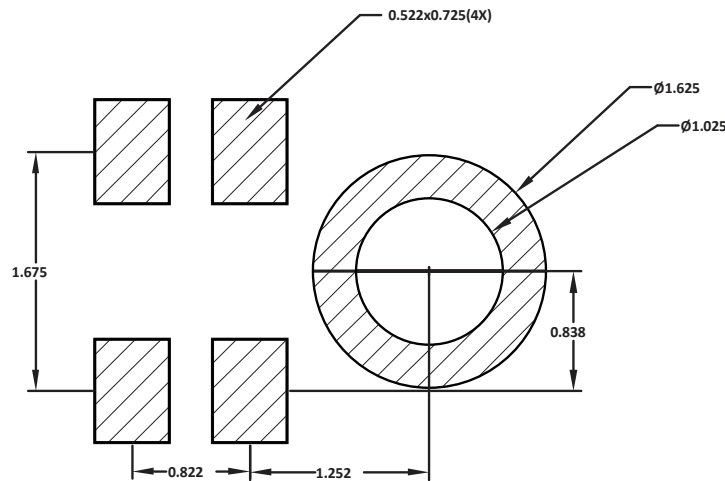

Figure 11. Recommended PCB Land Pattern Layout

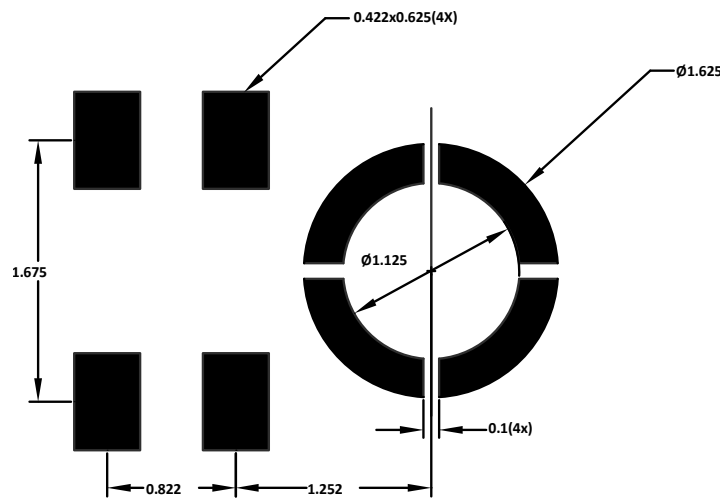

Figure 12. Recommended Solder Paste Stencil Pattern Layout

PCB MATERIAL AND THICKNESS

The performance of the ICS-40180 is not affected by PCB thickness. The ICS-40180 can be mounted on either a rigid or flexible PCB. A flexible PCB with the microphone can be attached directly to the device housing with an adhesive layer. This mounting method offers a reliable seal around the sound port while providing the shortest acoustic path for good sound quality.

HANDLING INSTRUCTIONS

PICK AND PLACE EQUIPMENT

The MEMS microphone can be handled using standard pick-and-place and chip shooting equipment. Take care to avoid damage to the MEMS microphone structure as follows:

- Use a standard pickup tool to handle the microphone. Because the microphone hole is on the bottom of the package, the pickup tool can make contact with any part of the lid surface.
- Do not pick up the microphone with a vacuum tool that makes contact with the bottom side of the microphone. Do not pull air out of or blow air into the microphone port.
- Do not use excessive force to place the microphone on the PCB.

REFLOW SOLDER

For best results, the soldering profile must be in accordance with the recommendations of the manufacturer of the solder paste used to attach the MEMS microphone to the PCB. It is recommended that the solder reflow profile not exceed the limit conditions specified in Figure 1 and Table 3.

BOARD WASH

When washing the PCB, ensure that water does not make contact with the microphone port. Do not use blow-off procedures or ultrasonic cleaning.

OUTLINE DIMENSIONS

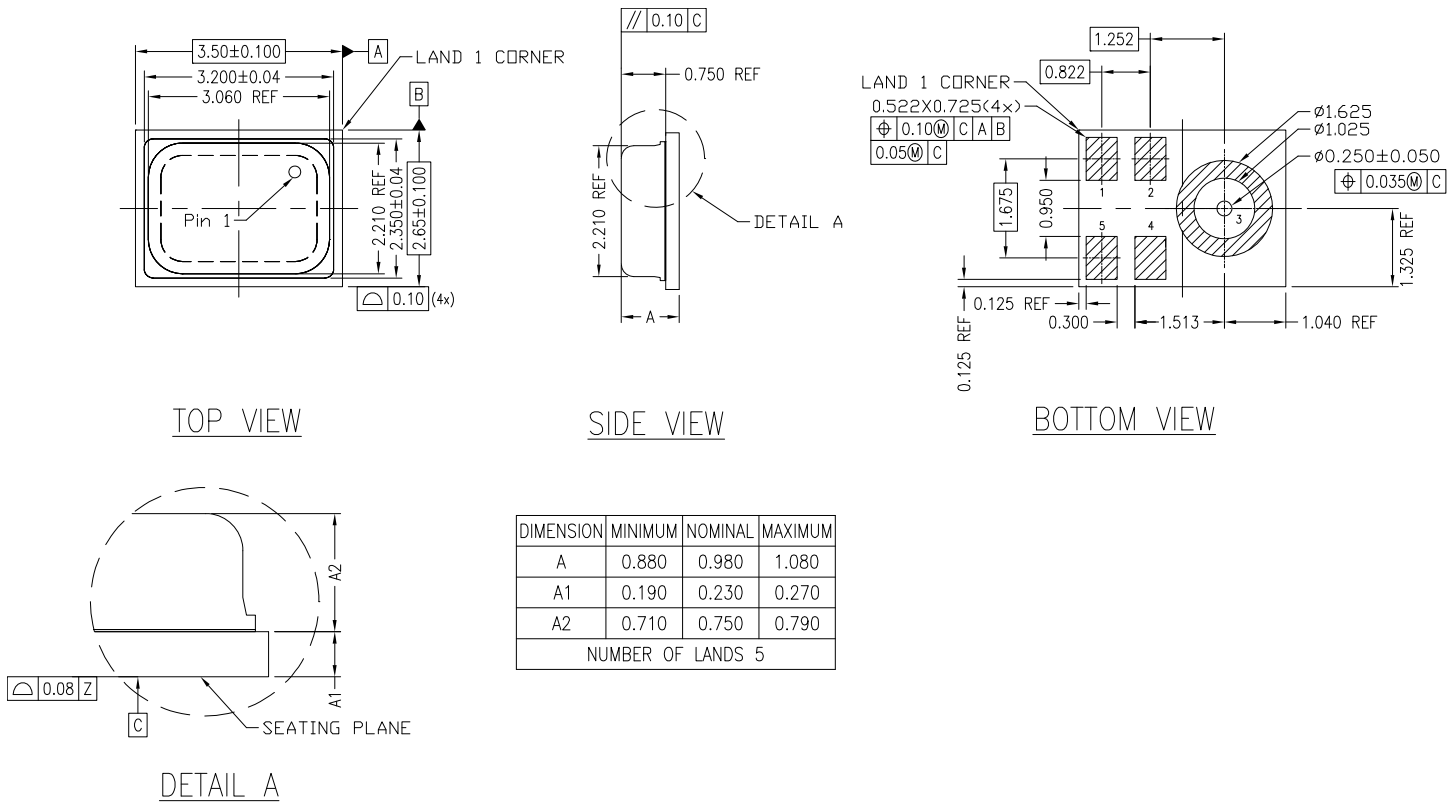

Figure 13. 5-Terminal Chip Array Small Outline No-Lead Cavity [LGA_CAV]
3.5 × 2.65 × 0.98 mm Body

Dimensions shown in millimeters

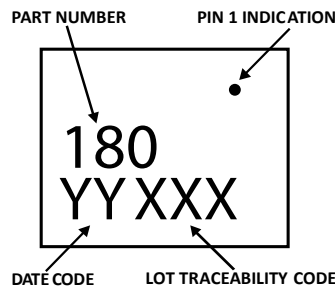

Figure 14. Package Marking Specification (Top View)

ORDERING GUIDE

| PART | TEMP RANGE | PACKAGE | QUANTITY | PACKAGING |
|-----------------|----------------|---------------------------|----------|-------------------|
| ICS-40180 | -40°C to +85°C | 5-Terminal LGA_CAV | 10,000 | 13" Tape and Reel |
| EV_ICs-40180-FX | — | Flexible Evaluation Board | — | |

REVISION HISTORY

| REVISION DATE | REVISION | DESCRIPTION |
|---------------|----------|--|
| 10/7/2014 | 1.0 | Initial Release |
| 11/17/2014 | 1.1 | Updated <i>General Description</i> information |
| 04/03/2015 | 1.2 | Corrected PSRR spec and replaced Figure 5 |

COMPLIANCE DECLARATION DISCLAIMER

InvenSense believes the environmental and other compliance information given in this document to be correct but cannot guarantee accuracy or completeness. Conformity documents substantiating the specifications and component characteristics are on file. InvenSense subcontracts manufacturing, and the information contained herein is based on data received from vendors and suppliers, which has not been validated by InvenSense.

This information furnished by InvenSense is believed to be accurate and reliable. However, no responsibility is assumed by InvenSense for its use, or for any infringements of patents or other rights of third parties that may result from its use. Specifications are subject to change without notice. InvenSense reserves the right to make changes to this product, including its circuits and software, in order to improve its design and/or performance, without prior notice. InvenSense makes no warranties, neither expressed nor implied, regarding the information and specifications contained in this document. InvenSense assumes no responsibility for any claims or damages arising from information contained in this document, or from the use of products and services detailed therein. This includes, but is not limited to, claims or damages based on the infringement of patents, copyrights, mask work and/or other intellectual property rights.

Certain intellectual property owned by InvenSense and described in this document is patent protected. No license is granted by implication or otherwise under any patent or patent rights of InvenSense. This publication supersedes and replaces all information previously supplied. Trademarks that are registered trademarks are the property of their respective companies. InvenSense sensors should not be used or sold in the development, storage, production or utilization of any conventional or mass-destructive weapons or for any other weapons or life threatening applications, as well as in any other life critical applications such as medical equipment, transportation, aerospace and nuclear instruments, undersea equipment, power plant equipment, disaster prevention and crime prevention equipment.

©2015 InvenSense, Inc. All rights reserved. InvenSense, MotionTracking, MotionProcessing, MotionProcessor, MotionFusion, MotionApps, DMP, AAR and the InvenSense logo are trademarks of InvenSense, Inc. Other company and product names may be trademarks of the respective companies with which they are associated.



©2015 InvenSense, Inc. All rights reserved.