

Graphics Display Truly 5.7" 640 x 480 Board Information Sheet

Features

- 5.7" VGA (640 x 480) TFT display with 24-bit parallel RGB interface and 4-wire resistive touch interface
- Resistive touch controller (AR1020) interfaced to the MCU through the SPI module
- Additional direct interface to MCU for 4-wire resistive touch signals

Getting Started

To get started, a display controller board with a display connector, such as the Graphics Controller PICtail™ Plus Epson S1D13517 Board (AC164127-7), is required. For details, refer to the related documentation (DS51948).

The Graphics Display Truly 5.7" 640 x 480 Board can be used with a display controller board in conjunction with the Graphics Library for Microchip microcontrollers. The Microchip Graphics Library and other firmware examples can be downloaded from <http://www.microchip.com/graphics>. Please refer to the "Getting Started" topic in the Microchip Graphics Library Help file in the Microchip Application Library (MAL) for information on using the board.

Board Settings

- Jumpers J1, J2, J3, and J4, select between the AR1020 touch controller interface and direct MCU interface for touch signals. J1-4 on positions 2-3 select the MCU interface, and on positions 2-1, selects the AR1020 touch interface (on positions 2-3 by default).
- Jumper J5 connects the interrupt signal, PEN_INT, from the display connector to the LED anode, which is used as a visual indication utility (closed by default)

TABLE 1: SIGNAL INTERFACE FOR DISPLAY CONNECTOR

Pin #	Symbol	Level	Description	Pin #	Symbol	Level	Description
A2, B2, A12, B12, A32, B32	GND	GND	Ground	A16	R5	I	Red Data
A3,A4	3.3V	3.3V	Power Supply	B15	R6	I	Red Data
A6	LEFT/X-	I/O	Touch Panel Left	A15	R7	I	Red Data
B6	TOP/Y-	I/O	Touch Panel Top	B25	G0	I	Green Data
A7	RIGHT/X+	I/O	Touch Panel Right	A25	G1	I	Green Data
B7	BOTTOM/Y+	I/O	Touch Panel Bottom	A22	G2	I	Green Data
A8	PEN_INT	O	Led Drive/SPI Interrupt From Touch Controller	B21	G3	I	Green Data
A9	SCK	I	Spi Clock	A21	G4	I	Green Data
B9	MOSI	I	Spi Input	B17	G5	I	Green Data
A10	MISO	O	Spi Output	A17	G6	I	Green Data
B10	CS	I	Spi Chip Select	B16	G7	I	Green Data
B11	BKLT_PWM	I	Pwm Input For Backlight Driver	B26	B0	I	Blue Data
A13	SHIFT	I	Pixel Shift Signal	A26	B1	I	Blue Data
B13	DEN	I	Data Enable	B23	B2	I	Blue Data
A14	FRAME	I	Frame Pulse	A23	B3	I	Blue Data
B14	LINE	I	Line Pulse	B22	B4	I	Blue Data
B24	R0	I	Red Data	A19	B5	I	Blue Data
A24	R1	I	Red Data	B18	B6	I	Blue Data
B20	R2	I	Red Data	A18	B7	I	Blue Data
A20	R3	I	Red Data	A1, B1, B3, B4, B8, A11, A29-31, B29-B31	NC	—	Not Connected
B19	R4	I	Red Data	B27	SPENA	—	LCD SPI Chip Select
A27	RESET	I	Glass Reset	B28	SPDA	I	LCD SPI Data
A28	SPCK	I	LCD SPI Clock				

Americas

Atlanta - 678-957-9614
 Boston - 774-760-0087
 Chicago - 630-285-0071
 Cleveland - 216-447-0464
 Dallas - 972-818-7423
 Detroit - 248-538-2250
 Kokomo - 765-864-8360
 Los Angeles - 949-462-9523
 Phoenix - 480-792-7200
 Santa Clara - 408-961-6444
 Toronto - 905-673-0699

Asia/Pacific

Australia - Sydney - 61-2-9868-6733
 China - Beijing - 86-10-8528-2100
 China - Chengdu - 86-28-8665-5511
 China - Chongqing - 86-23-8980-9588
 China - Hong Kong SAR - 852-2401-1200
 China - Nanjing - 86-25-8473-2460
 China - Qingdao - 86-532-8502-7355
 China - Shanghai - 86-21-5407-5533
 China - Shenyang - 86-24-2334-2829
 China - Shenzhen - 86-755-8203-2660
 China - Wuhan - 86-27-5980-5300
 China - Xiamen - 86-592-2388138
 China - Xian - 86-29-8833-7252
 China - Zhuhai - 86-756-3210040
 India - Bangalore - 91-80-3090-4444
 India - New Delhi - 91-11-4160-8631
 India - Pune - 91-20-2566-1512
 Japan - Yokohama - 81-45-471-6166
 Korea - Daegu - 82-53-744-4301
 Korea - Seoul - 82-2-554-7200
 Malaysia - Kuala Lumpur - 60-3-6201-9857
 Malaysia - Penang - 60-4-227-8870
 Philippines - Manila - 63-2-634-9065
 Singapore - 65-6334-8870
 Taiwan - Hsin Chu - 886-3-6578-300
 Taiwan - Kaohsiung - 886-7-213-7830
 Taiwan - Taipei - 886-2-2500-6610
 Thailand - Bangkok - 66-2-694-1351

Europe

Austria - Weis - 43-7242-2244-39
 Denmark - Copenhagen - 45-4450-2828
 France - Paris - 33-1-69-53-63-20
 Germany - Munich - 49-89-627-144-0
 Italy - Milan - 39-0331-742611
 Netherlands - Drunen - 31-416-690399
 Spain - Madrid - 34-91-708-08-90
 UK - Wokingham - 44-118-921-5869

08/04/10



MICROCHIP

Microchip Technology Inc. • 2355 West Chandler Blvd. • Chandler, AZ 85224-6199

www.microchip.com

The Microchip name and logo, the Microchip logo, and MPLAB are registered trademarks of Microchip Technology Incorporated in the U.S.A. and other countries. All other trademarks mentioned herein are property of their respective companies.

© 2011, Microchip Technology Incorporated, Printed in the U.S.A. All Rights Reserved. 08/10

DS00000A

Graphics Display Truly 5.7" 640 x 480 Board Information Sheet

Schematics (Sheet 1 of 2)

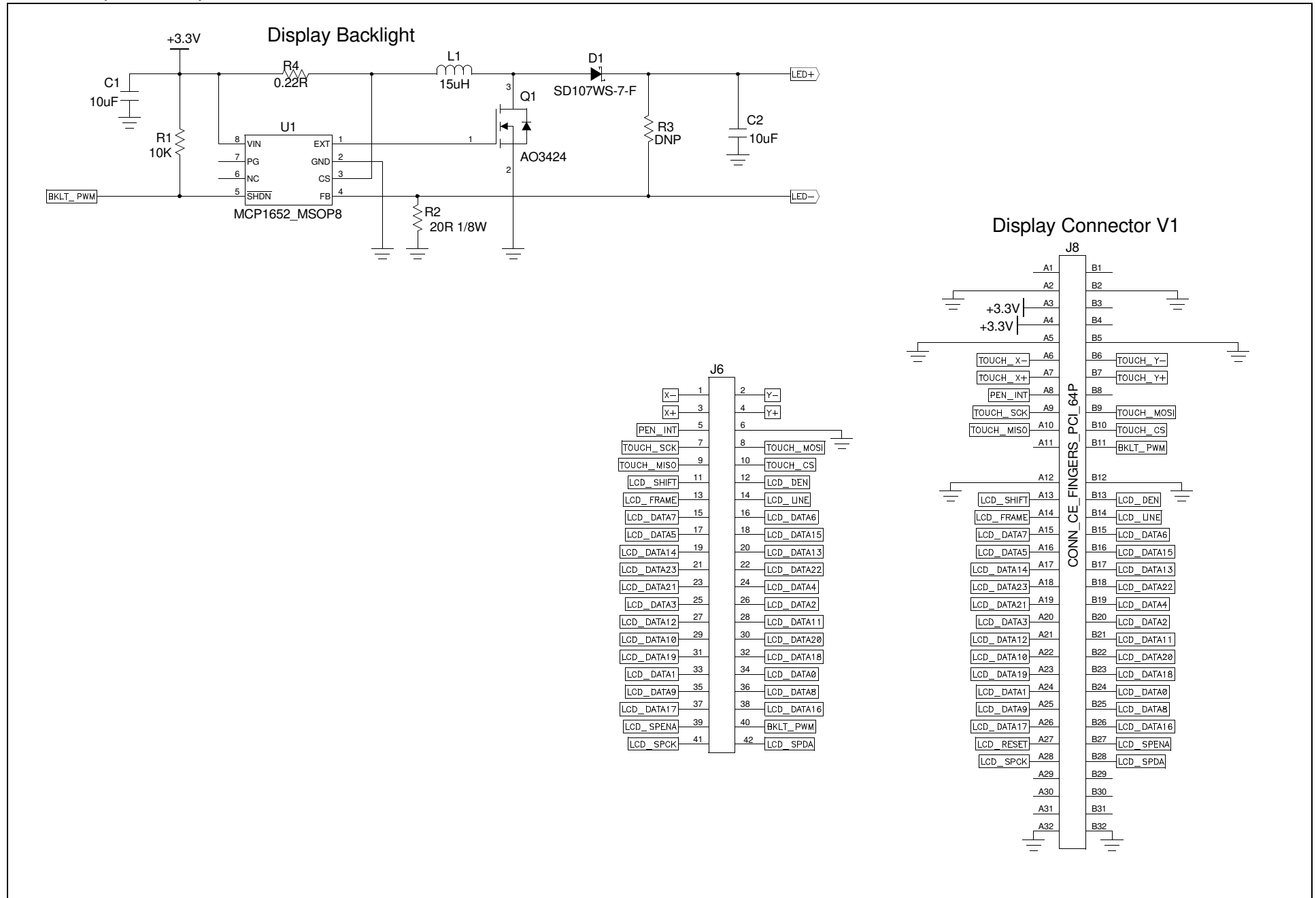

Graphics Display Truly 5.7" 640 x 480 Board Information Sheet

Schematics (Sheet 2 of 2)

