

LOC	DIST	REV	DESCRIPTION	DATE	OWN	APVD
ES	00	A2	CORRECT DRAFT ERROR	09APR2013	OL	SZ

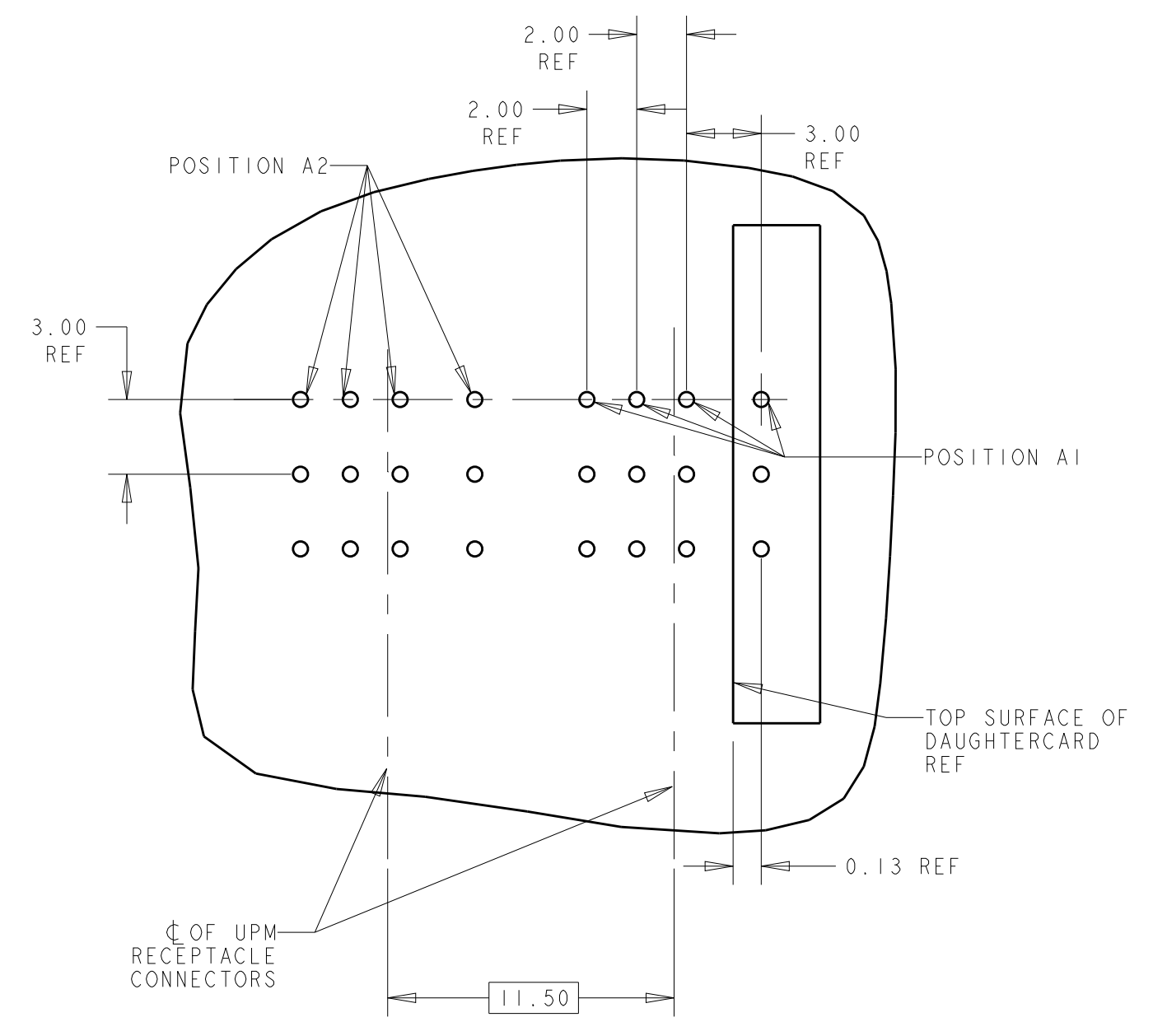

MATING VERTICAL UPM RECEPTACLE PCB LAYOUT 3

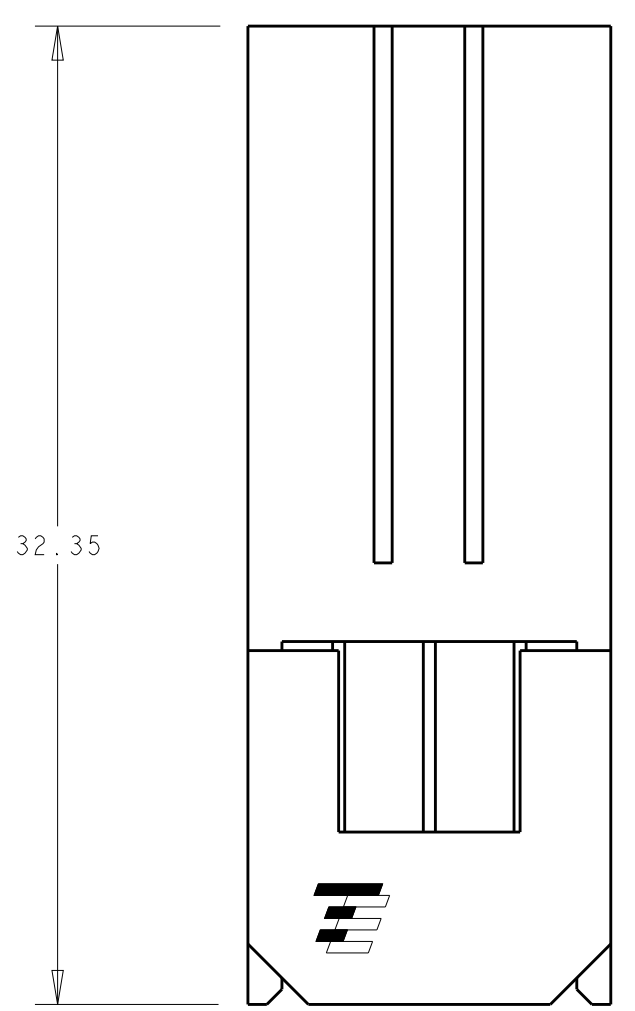

- 1 MATERIAL: HOUSING: POLYESTER. COLOR: BLACK, UL 94 V-0  
CONTACT: COPPER ALLOY.
- 2 FINISH: CONTACT MATING AREA: 0.00076 mm MIN GOLD PLATE OVER 0.00127 mm MIN NICKEL, OR 0.0005 mm MIN GOLD OVER 0.00064 mm PALLADIUM-NICKEL OVER 0.00127 mm MIN NICKEL.  
COMPLIANT TAIL AREA: 0.0005 mm MIN MATTE TIN PLATE OVER 0.00127 mm NICKEL UNDERPLATE.
- 3 TAILS OF MATING UPM STYLE RECEPTACLE ARE OFFSET BY 0.75 mm FROM TAILS OF THIS CONNECTOR. SEE CUSTOMER DRAWING 120992 FOR RECEPTACLE EXAMPLE. SEE APPLICATION SPEC 114-1103 FOR MORE DETAILED DESCRIPTION OF THE TAIL OFFSETS.
- 4 PC BOARD HOLE SPECIFICATIONS:  
 DRILLED HOLE SIZE: 0.700±0.02 mm  
 FINISHED HOLE SIZE: 0.60±0.05 mm  
 PLATING THICKNESS:  
 0.025 - 0.050 mm COPPER  
 0.004 - 0.010 mm HASL TIN  
 0.0005 mm MIN IMMERSION TIN  
 0.0002 - 0.0005 mm OSP  
 0.0001mm MIN IMMERSION SILVER  
 0.0001-0.0005 mm IMMERSION GOLD OVER 0.004-0.005 mm NICKEL
- 5 DATUM AND BASIC DIMENSION ESTABLISHED BY CUSTOMER.
- 6 MINIMUM REQUIRED PC BOARD THICKNESS IS 1.44mm.
- 7 CONTACT AREA LUBRICATED WITH BELLCORE APPROVED LUBRICANT. TECHNICAL REFERENCE GR-1217-CORE, ISSUE 1 NOVEMBER 1995.
- 8 POSITION A1 IS AT MATERIAL ID.

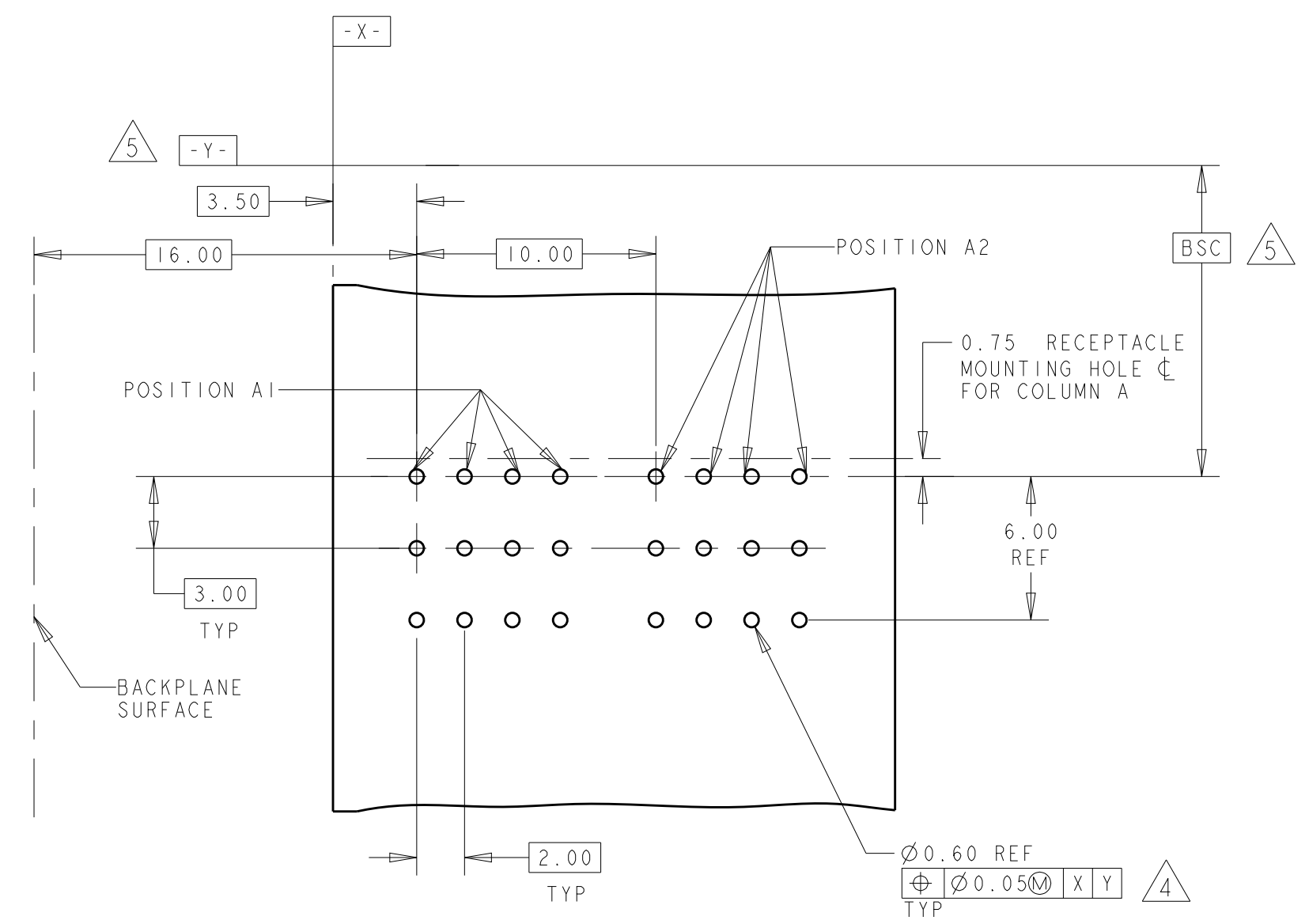
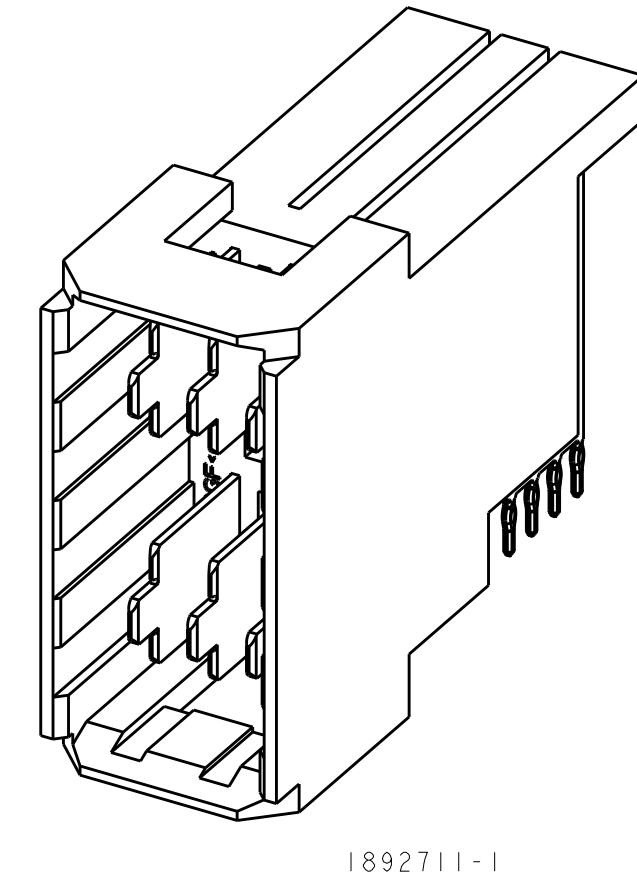
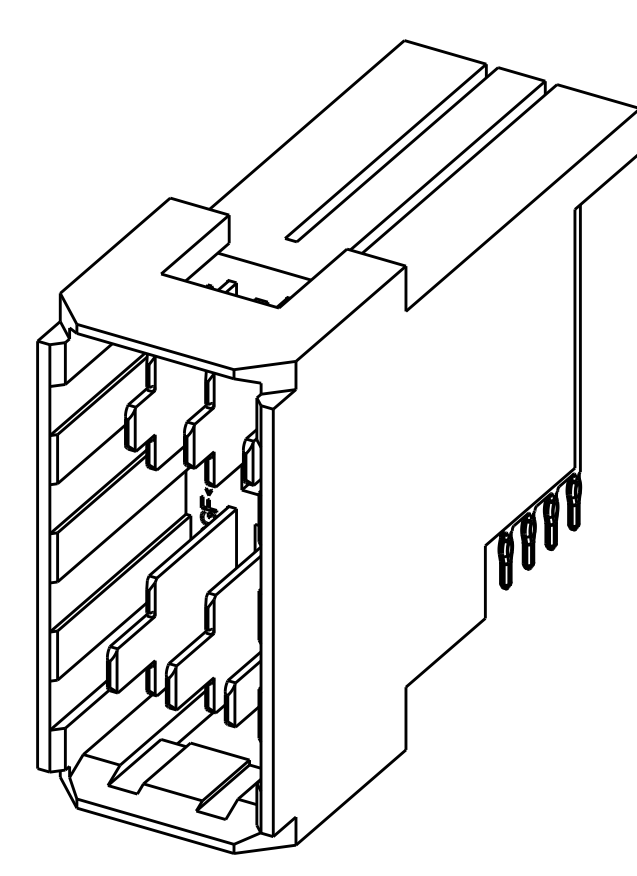

RECOMMENDED PCB LAYOUT 6

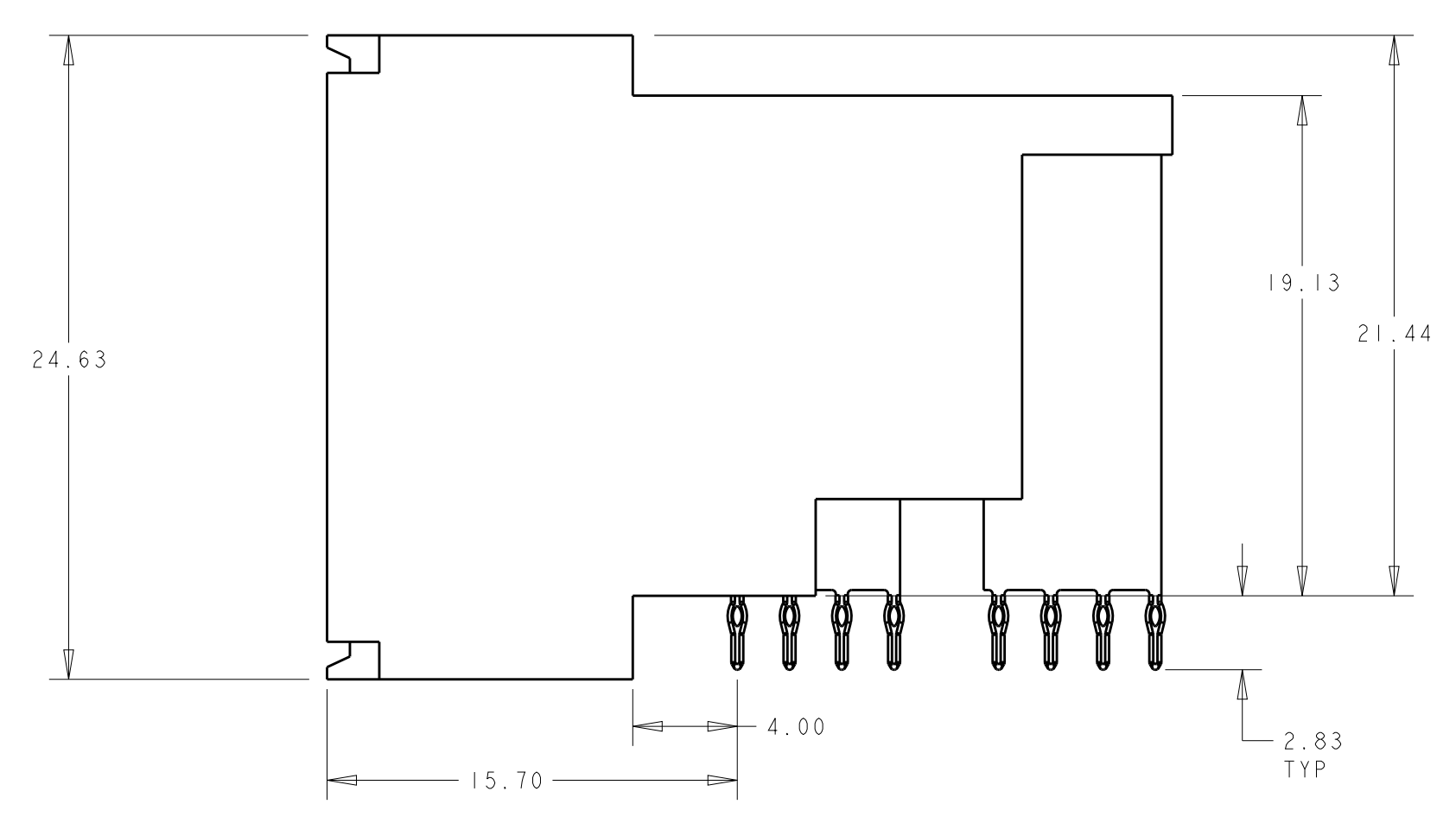
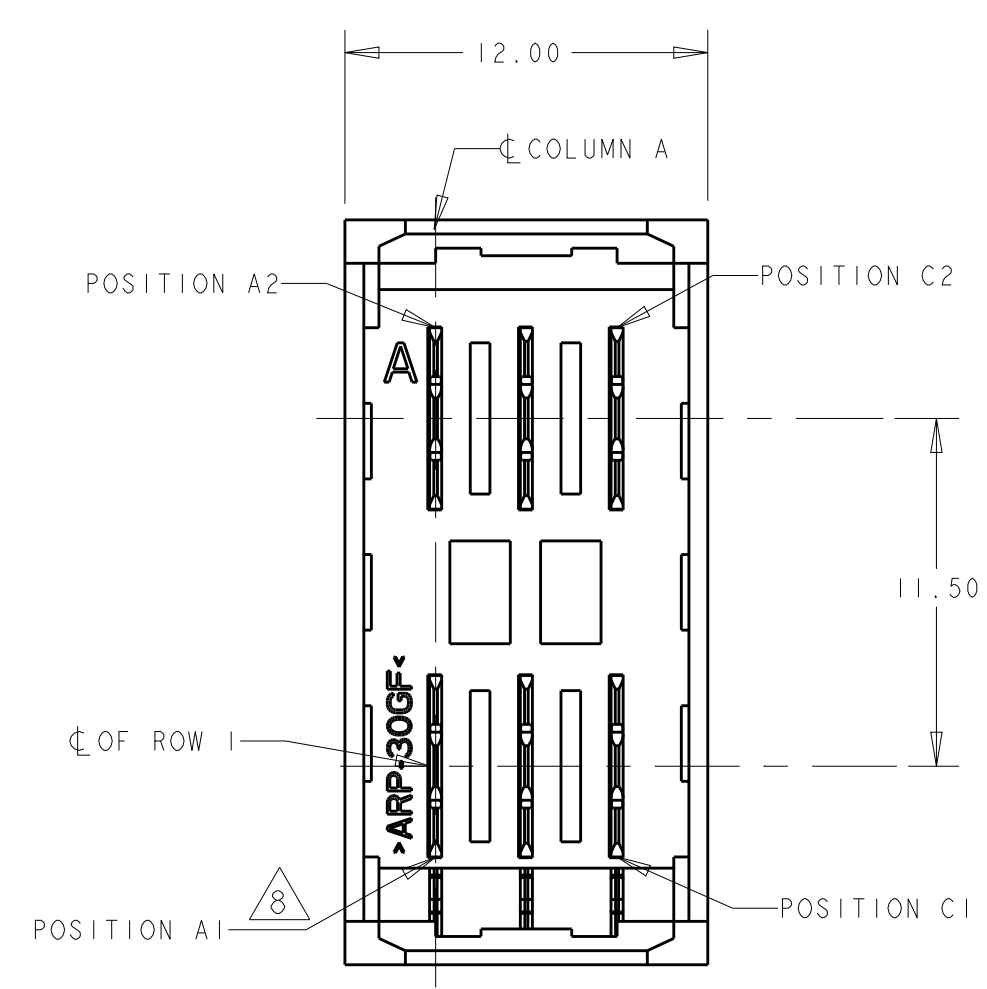

BI	C1	A1, A2, B2, C2	1892711-3
-	A1, B1, C1	A2, B2, C2	1892711-2
-	-	ALL	1892711-1
POSITION LOADED WITH 7.7 REF SHORT PIN		POSITION LOADED WITH 10.92 REF LONG PIN	POSITION LOADED WITH 9.32 REF MIDDLE PIN
PART NO		PART NO	

DIMENSIONS: mm 0 PLC ±.25 1 PLC ±.25 2 PLC ±.25 3 PLC ±.25 4 PLC ±.25 ANGLES ±1°	TOLERANCES UNLESS OTHERWISE SPECIFIED: FINISH 2	DWN: LORANDO LI CHK: SUNY ZHAO APVD: STEVEN YAO DATE: 23JUN2009	Tyco Electronics Shanghai, P.R. China. 200233
MATERIAL 1		NAME: ASSEMBLY, RIGHT ANGLE HEADER, MINIPAK HDE, 2X3 POSITION	
WEIGHT: -		SIZE: CAGE CODE DRAWING NO: A100779C=1892711	
Customer Drawing		SCALE: 5:1 SHEET 1 OF 1 REV: A2	