

FCI CONFIDENTIAL

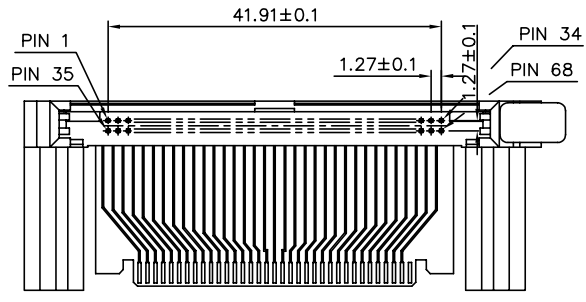

This document is the property of and embodies CONFIDENTIAL and PROPRIETARY information of FCI. No part of this information shown on this document may be used in any way or disclosed to others without the written consent of FCI. Copyright FCI.

PRODUCT NO.
74031-118CA/118CALF
74031-118MCALF

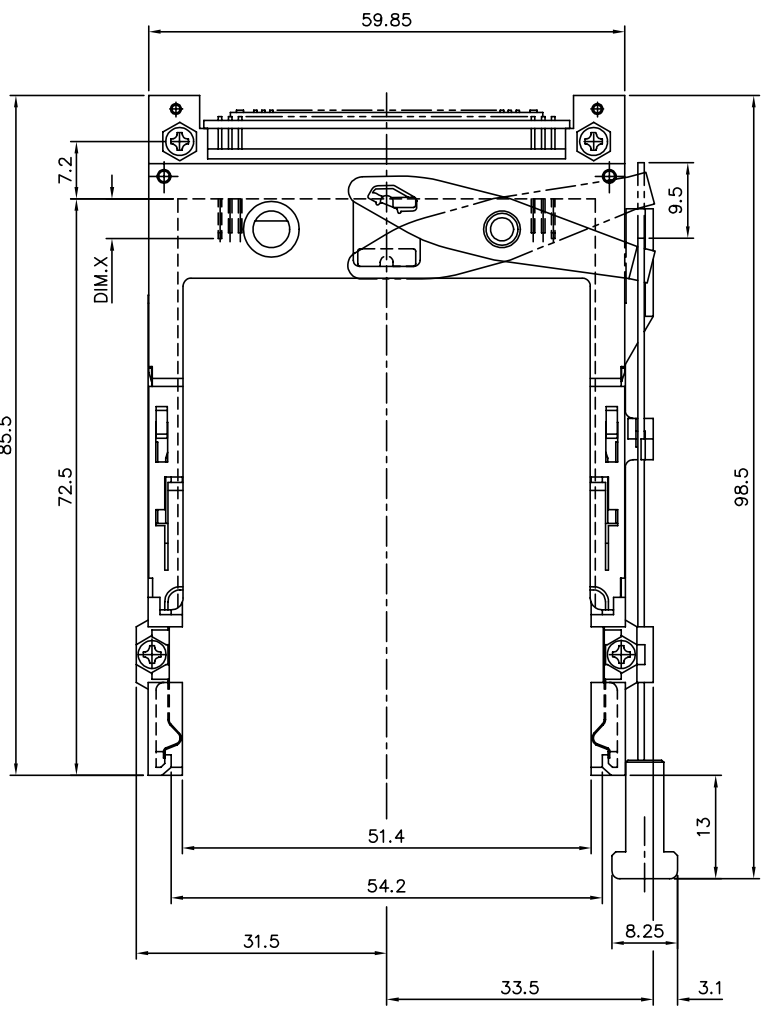
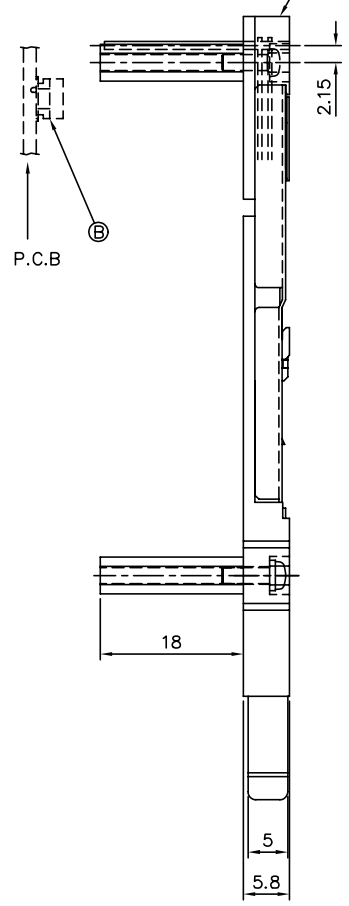

**NOTES:**

1. 8mm MIN. CARD EJECT.
2. EJECT TRAVEL: 9.5mm
3. PUSH ROD LOCATION AND P.C.B. SIDE ARE AS APPEARS INSTALLED.
4. MATERIAL
  - 4.1 HEADER ASS'Y
    - HOUSING: HIGH TEMPERATURE THERMOPLASTIC UL94V-0 BLACK
    - PIN : COPPY ALLOY
    - PCB : FR4
  - 4.2 MECHANISM ASS'Y
    - PLASTIC : GUIDE: HIGH TEMPERATURE THERMOPLASTIC UL94V-0 BLACK
    - : BUTTON: HIGH TEMPERATURE THERMOPLASTIC UL94V-0 BLACK
    - PLATE AND PUSH ROD : STAINLESS
    - EMI CONTACT: PHOSPHOR BRONZE
    - STAND-OFF : BRASS
5. FINISH (PIN)
  - UNDER PLATING : 0.5 um MIN. Ni
  - CONTACT AREA : 0.076 um MIN. GOLD

SPECIAL COST PLATING IS 0.25um GOLD

  - SOLDER TAIL : 2.5 um MIN. Sn-Pb ( FOR TIN LEAD OPTION)
  - 2.5 um MIN. PURE TIN (FOR LEAD FREE OPTION)
  - STAND-OFF : 3 um MIN. Ni.
6. DIM "X"
 

4.25±0.1	3.5±0.1	5.0±0.1
OTHERS	36,67	1,17,34,35,51,68
7. RECOMMENDED M2 SCREW LENGTH( l ): 5.0mm MIN.~15.0mm MAX.
8. IF LEAD FREE P.N.THE HOUSING WILL WITHSTAND EXPOSURE TO 260°C PEAK TEMPERATURE FOR 10 SECONDS IN A WAVE SOLDER APPLICATION WITH A 1.00MM MINIMUM THICK CIRCUIT BOARD.
9. IF LEAD FREE P/N.THE PRODUCT MEETS EUROPEAN UNION DIRECTIVES AND OTHER COUNTRY REGULATIONS AS DESCRIBED IN GS-22-008
10. LEAD FREE P/N PACKAGING MEETS GS-14-920 SPECIFICATION
11. PRODUCT SPEC: 110-263

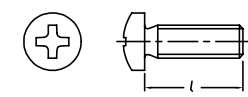

**ORDERING INFORMATION**

NAME	PART NO.	Q'TY
Ⓐ EJECT HEADER ASS'Y	74031-118CA/118CALF	1
Ⓑ MATING RECEPTACLE	91931-31169/31169LF/31169LF	1

mat'l. code		surface	tolerance	projection	product family													
		ISO 1302	ISO 406 ISO 1101	1101	PCMCIA													
ltr	ecn	no	dr	date	tolerances unless otherwise specified													
A	T70299	W	L	09/08/97	angles													
B	T90062	W	L	02/24/99	linear													
C	T00304	W	L	10/09/00	±2'													
D	T03-0254	W	L	06/25/03	dr													
E	N05-0125	W	B	05/10/05	engr													
F	N06-0110	M	Z	06/22/06	chr													
G	ELX-N-011413	ZK		04/25/12	appa													
		Jack Wang		06/05/06														
sheet		revision	G	G	G	G	G											
index		sheet	1	2	3	4	5											



FCI CONFIDENTIAL



This document is the property of and embodies CONFIDENTIAL and PROPRIETARY information of FCI. No part of this information shown on this document may be used in any way or disclosed to others without the written consent of FCI.  
Copyright FCI.

PART NUMBER
74031-118CA/118CALF
74031-118MCALF

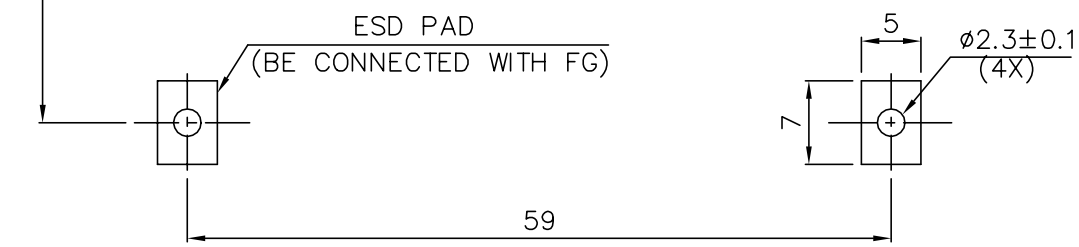
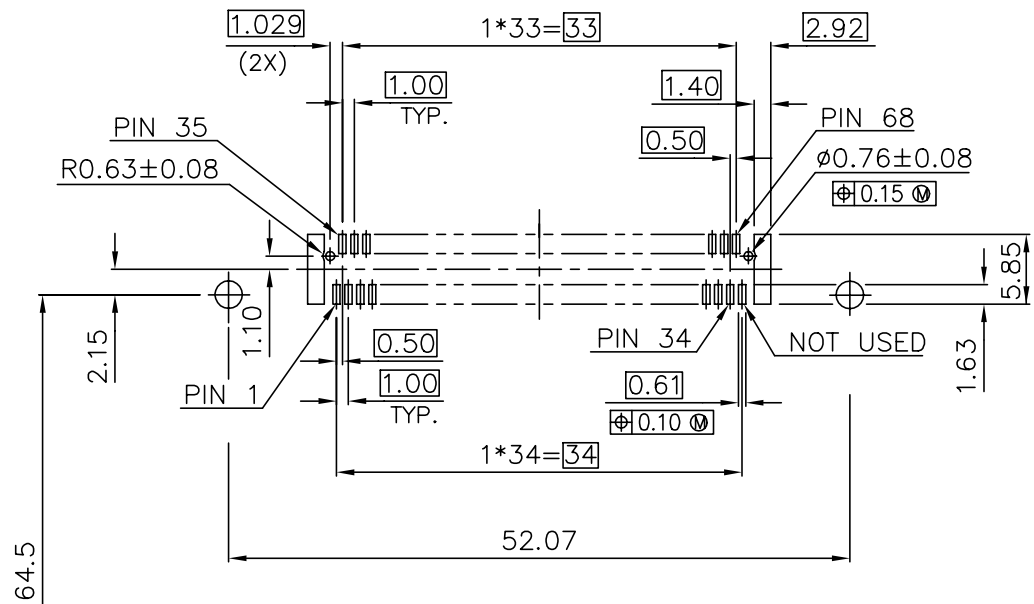

BOARD VIEW FROM CONNECTOR MOUNTED SIDE  
TOP OF BOARD IN APPLICATION

mat'l. code	surface	tolerance	projection	product family
	ISO 1302	ISO 406 ISO 1181	ISO 1181	PCMCIA
ltr ecn no dr date	tolerances unless otherwise specified			title
G	angles	.X±.3	linear	68 POS EJECTOR HEADER HSG
	±2'	.XX±.13	scale	
		.XXX±.051	MM	
dr	Mike Zhou	06/05/06	FCI	dwg no
enr	Mike Zhou	06/05/06		sheet 2 of 5
chr	Mike Zhou	06/05/06		size
app	Jack Wang	06/05/06		A4
sheet index	revision sheet			type CUSTOMER Drawing

FCI CONFIDENTIAL

FCI  
FCIconnect.com

This document is the property of and embodies CONFIDENTIAL and PROPRIETARY information of FCI. No part of this information shown on this document may be used in any way or disclosed to others without the written consent of FCI.  
Copyright FCI.

PRODUCT NO.  
74031-080DA  
74031-080DALF

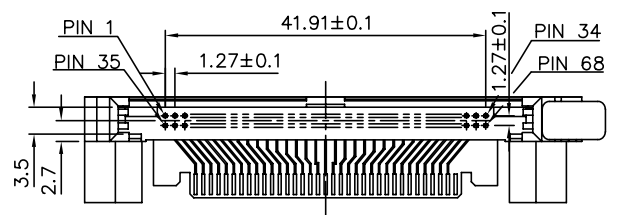
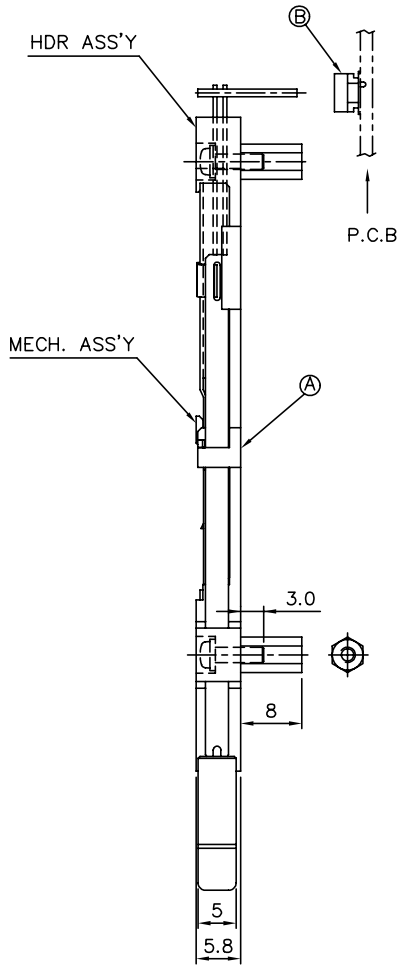
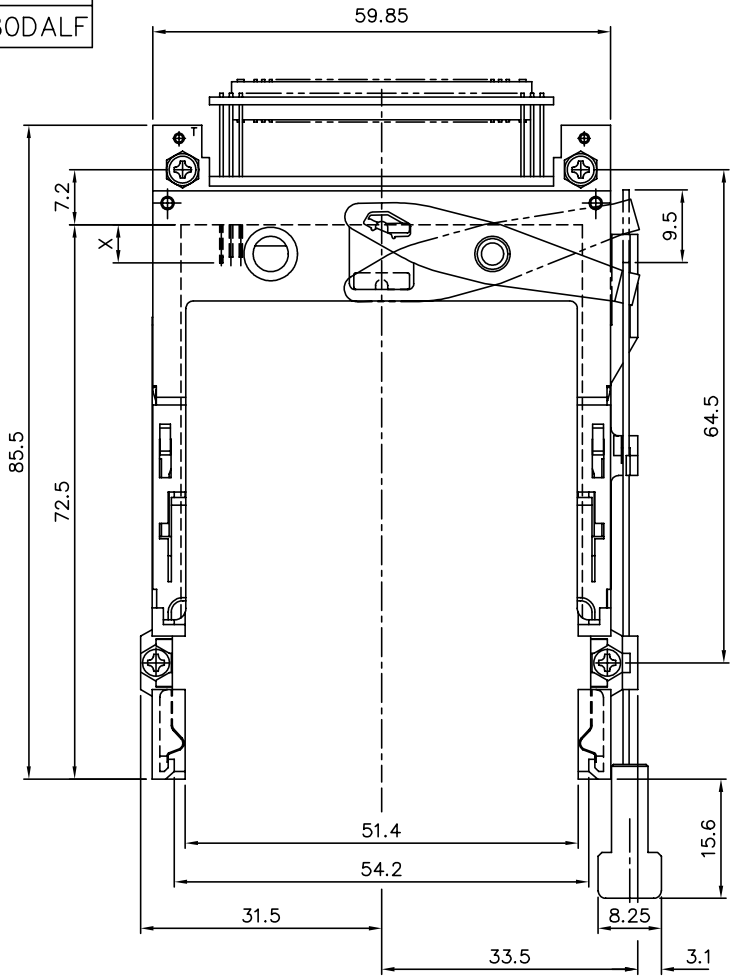

ABOVE P.C.B.  
(RIGHT PUSH-ROD)

NOTES:

- 8mm MIN. CARD EJECT.
- EJECT TRAVEL: 9.5mm
- PUSH ROD LOCATION AND P.C.B. SIDE ARE AS APPEARS INSTALLED.
- MATERIAL
  - HEADER ASS'Y
    - PLASTIC : HOUSING ...HIGH TEMPERATURE THERMOPLASTIC UL94V-0 BLACK
    - PIN : PHOSPHOR BRONZE
    - PCB : FR4
  - MECHANISM ASS'Y
    - PLASTIC : GUIDE: HIGH TEMPERATURE THERMOPLASTIC UL94V-0 BLACK
    - : BUTTON: HIGH TEMPERATURE THERMOPLASTIC UL94V-0 BLACK
    - PLATE AND PUSH ROD : STAINLESS
    - EMI CONTACT: PHOSPHOR BRONZE
    - STAND-OFF : BRASS
- FINISH (PIN)
  - UNDER PLATING : 0.5 um MIN. Ni
  - CONTACT AREA : 0.076 um MIN. GOLD
  - SOLDER TAIL : 2.5 um MIN. Sn-Pb ( FOR TIN LEAD OPTION)
  - : 2.5 um MIN. PURE TIN (FOR LEAD FREE OPTION)
  - STAND-OFF : 3 um MIN. Ni.
- DIM "X"
 

4.25±0.1	3.5±0.1	5.0±0.1
OTHERS	36,67	1,17,34,35,51,68
- IF LEAD FREE P/N.THE HOUSING WILL WITHSTAND EXPOSURE TO 260°C PEAK TEMPERATURE FOR 10 SECONDS IN A WAVE SOLDER APPLICATION WITH A 1.00MM MINIMUM THICK CIRCUIT BOARD.
- IF LEAD FREE P/N.THE PRODUCT MEETS EUROPEAN UNION DIRECTIVES AND OTHER COUNTRY REGULATIONS AS DESCRIBED IN GS-22-008
- LEAD FREE P/N PACKAGING MEETS GS-14-920 SPECIFICATION
- PRODUCT SPEC: 110-263

ORDERING INFORMATION

NAME	PART NO.	Q'TY
(A) EJECT HEADER ASS'Y	74031-080DA/080DALF	1
(B) MATING RECEPTACLE	91931-31169/31169LF	1

mat'l. code	surface ISO 1302	tolerance ISO 406 ISO 1101	projection 1:1	product family PCMCIA
ltr ecn no dr date	tolerances unless otherwise specified			title 68 POS EJECTOR HEADER HSG (FOR 5.0V)
g	angles ±2'	linear ±0.3	MM	dwg no 74031
	dr Mike Zhou 06/05/06	engr Mike Zhou 06/05/06	chr Mike Zhou 06/05/06	sheet 3 of 5 size A4
	appd Jack Wang 06/05/06			type CUSTOMER Drawing
sheet index	revision sheet			

FCI CONFIDENTIAL

FCI  
FCIconnect.com

This document is the property of and embodies CONFIDENTIAL and PROPRIETARY information of FCI. No part of this information shown on this document may be used in any way or disclosed to others without the written consent of FCI.  
Copyright FCI.

PRODUCT NO.  
74031-180DA/180DALF

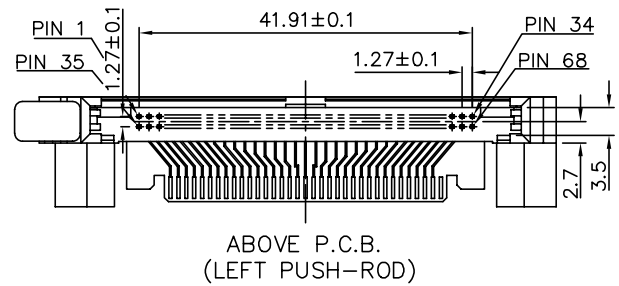
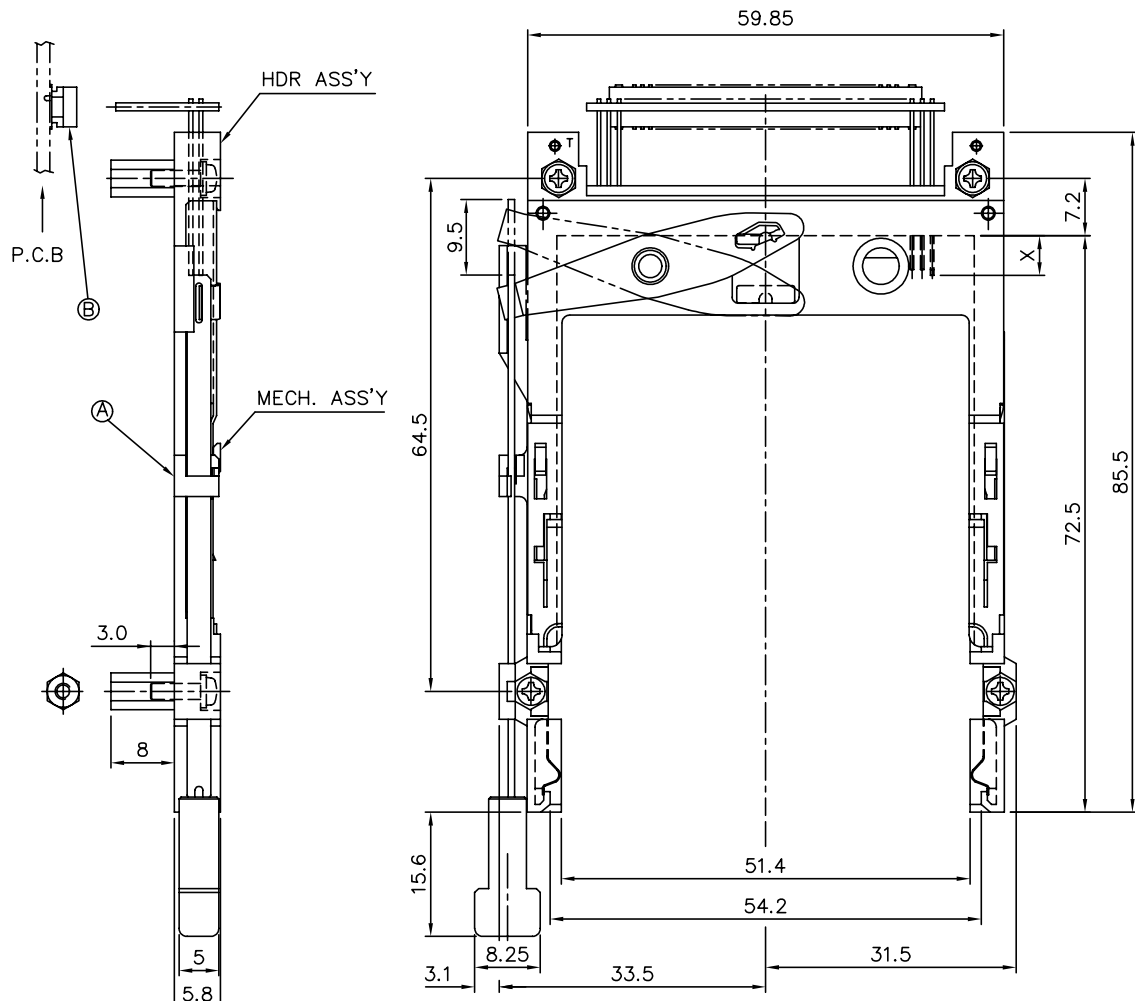

NOTES:

- 8mm MIN. CARD EJECT.
- EJECT TRAVEL: 9.5mm
- PUSH ROD LOCATION AND P.C.B. SIDE ARE AS APPEARS INSTALLED.
- MATERIAL
  - HEADER ASS'Y
    - PLASTIC : HOUSING ...HIGH TEMPERATURE THERMOPLASTIC UL94V-0 BLACK
    - PIN : PHOSPHOR BRONZE
    - PCB : FR4
  - MECHANISM ASS'Y
    - PLASTIC : GUIDE: HIGH TEMPERATURE THERMOPLASTIC UL94V-0 BLACK
    - : BUTTON: HIGH TEMPERATURE THERMOPLASTIC UL94V-0 BLACK
    - PLATE AND PUSH ROD : STAINLESS
    - EMI CONTACT: PHOSPHOR BRONZE
    - STAND-OFF : BRASS
- FINISH (PIN)
  - UNDER PLATING : 0.5 um MIN. Ni
  - CONTACT AREA : 0.076 um MIN. GOLD
  - SOLDER TAIL : 2.5 um MIN. Sn-Pb ( FOR TIN LEAD OPTION)
  - : 2.5 um MIN. PURE TIN (FOR LEAD FREE OPTION)
  - STAND-OFF : 3 um MIN. Ni.
- DIM "X"
 

4.25±0.1	3.5±0.1	5.0±0.1
OTHERS	36,67	1,17,34,35,51,68
- IF LEAD FREE P.N.THE HOUSING WILL WITHSTAND EXPOSURE TO 260°C PEAK TEMPERATURE FOR 10 SECONDS IN A WAVE SOLDER APPLICATION WITH A 1.00MM MINIMUM THICK CIRCUIT BOARD.
- IF LEAD FREE P/N.THE PRODUCT MEETS EUROPEAN UNION DIRECTIVES AND OTHER COUNTRY REGULATIONS AS DESCRIBED IN GS-22-008
- LEAD FREE P/N PACKAGING MEETS GS-14-920 SPECIFICATION
- PRODUCT SPEC: 110-263

ORDERING INFORMATION

NAME	PART NO.	Q'TY
(A) EJECT HEADER ASS'Y	74031-180DA/180DALF	1
(B) MATING RECEPTACLE	91931-31169/31169LF	1

mat'l. code	surface ISO 1302	tolerance ISO 406 ISO 1101	projection MM	product family PCMCIA
ltr ecn no dr date	tolerances unless otherwise specified			title 68 POS EJECTOR HEADER HSG (FOR 5.0V)
g	angles ±2'	linear ±0.3	scale	dwg no 74031
dr	Mike Zhou	06/05/06		sheet 4 of 5 size A4
enr	Mike Zhou	06/05/06		type CUSTOMER Drawing
chr	Mike Zhou	06/05/06		
appd	Jack Wang	06/05/06		
sheet index	revision sheet			

FCI CONFIDENTIAL

FCI

This document is the property of and embodies CONFIDENTIAL and PROPRIETARY information of FCI. No part of the information shown on this document may be used in any way or disclosed to others without the written consent of FCI. Copyright FCI.

PRODUCT NO.
74031-080DA
74031-180DA
74031-080DALF
74031-180DALF

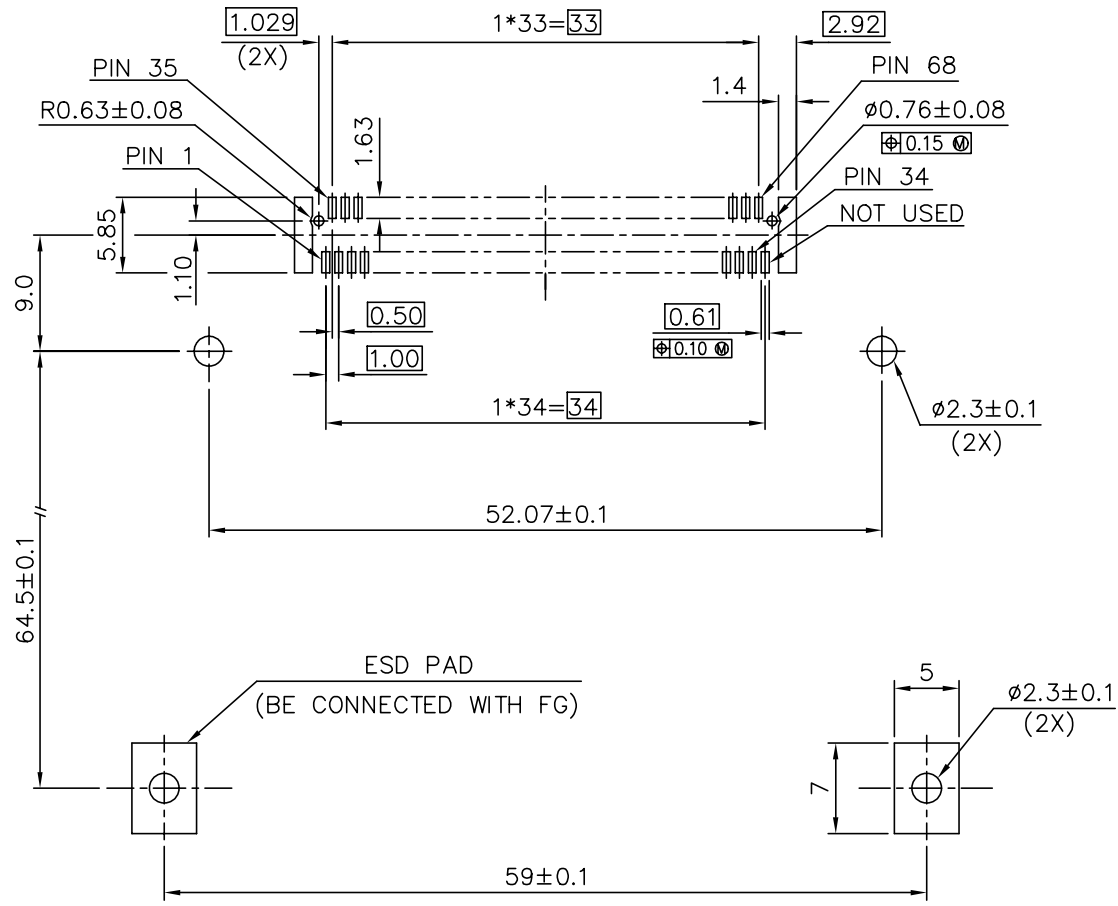

4 CARD INSERTION DIRECTION

mat'l. code	surface	tolerance	projection	product family
	ISO 1302	ISO 406 ISO 1101		PCMCIA
ltr ecn no dr date	tolerances unless otherwise specified			title
G	±0.3			EJECTOR HEADER ASS'Y 68POS. SMT, TYPE 1/2/3
	angles	linear	MM	
	±2°		scale	
dr	Mike Zhou	06/05/06	FCI	dwg no
engr	Mike Zhou	06/05/06		sheet 5 of 5
chr	Mike Zhou	06/05/06		size
appd	Jack Wang	06/05/06		A4
sheet index	revision sheet			type CUSTOMER Drawing