

【 1. 適用範囲 SCOPE 】

本仕様書は、\_\_\_\_\_ 殿 に納入する

\_\_\_\_\_ 1.5mm ピッチ 電線対基板 コネクタ ( 1列品 ) \_\_\_\_\_ について規定する。

This specification covers the 1.5 mm PITCH WIRE TO BOARD CONNECTOR (SINGLE TYPE) series

【 2. 製品名称及び型番 PRODUCT NAME AND PART NUMBER 】

製品名称 Product Name	製品型番 Part Number
プラグ ターミナル Plug Terminal	5 0 2 5 7 9 - 0 * 0 0 5 0 3 4 2 9 - 0 0 0 0
プラグ ハウジング(ポジティブロック付き) Plug Housing (With Positive Lock)	5 0 2 5 7 8 - * * * *
ライトアングル リセ アセンブリ Right Angle Receptacle Assembly	5 0 3 1 7 5 - * * * *

\* : 図面参照 Refer to the drawing.

【 3. 定格及び適用電線 RATINGS AND APPLICABLE WIRES 】

項目 Item	規格 Standard	
最大許容電圧 Rated Voltage (MAX.)	100 V	
最大許容電流 及び 適用電線 Rated Current ( MAX. ) and Applicable wires	AWG#24	2.0A
	AWG#26	1.5A
	AWG#28	1.0A
	AWG#30	1.0A
使用温度範囲 Ambient Temperature Range (Operating and Non-operating)	-40°C ~ + 105°C*1 低温において氷結しないこと Not freeze to low temperature	

\*1 : 通電による温度上昇分も含む。 Including terminal temperature rise.

REV.	J			
SHEET	1-16			
REVISE ON PC ONLY			TITLE:	
<b>J</b>	変更 REVISED J2015-1447 '15/09/17 T.AKAIKE		1.5mm PITCH WIRE TO BOARD CONNECTOR SINGLE DIP R/A TYPE <b>製品仕様書</b>	
	DESCRIPTION		THIS DOCUMENT CONTAINS INFORMATION THAT IS PROPRIETARY TO MOLEX INC. AND SHOULD NOT BE USED WITHOUT WRITTEN PERMISSION	
DESIGN CONTROL	J	STATUS	WRITTEN BY: N.NISHI	CHECKED BY: SMARUYA
			APPROVED BY: S.ICHIKAW	DATE : YR/MO/DAY 2008/10/22

DOCUMENT NUMBER <b>PS-503175-001</b>	FILE NAME PS-503175-001.docx	SHEET 1 OF 16
---	---------------------------------	------------------

項目 Item	規格 Standard	
推奨保管条件 Recommended Storage condition	温度 Temperature	+5°C~+35°C
	湿度 Humidity	60% R.H. Max. 但し結露しないこと No condensation permitted.
	保管期間 Term of Storage	出荷後6ヶ月（未開封の場合） 6 months after the product is stocked. (unopened package)

REVISE ON PC ONLY		TITLE:	
<b>J</b>	SEE SHEET 1 OF 16	1.5mm PITCH WIRE TO BOARD CONNECTOR SINGLE DIP R/A TYPE	
		<b>製品仕様書</b>	
REV.	DESCRIPTION	THIS DOCUMENT CONTAINS INFORMATION THAT IS PROPRIETARY TO MOLEX INC. AND SHOULD NOT BE USED WITHOUT WRITTEN PERMISSION	
DOCUMENT NUMBER <b>PS-503175-001</b>		FILE NAME PS-503175-001.docx	SHEET 2 OF 16
EN-037(2015-09 rev.4)			

【 4 . 性能 PERFORMANCE 】

4 - 1 .電氣的性能 Electrical performance

項 目 Item		条 件 Test Condition	規 格 Requirement
4-1-1	接 触 抵 抗 Contact Resistance	コネクタを嵌合させ、開放電圧 20mV以下、短絡電流 10mA にて測定する。 (JIS C5402 5.4)  Mate connectors and measured by dry circuit, 20mV MAX., 10mA. (JIS C5402 5.4)	20 milliohms MAX.
4-1-2	絶 縁 抵 抗 Insulation Resistance	コネクタを嵌合させ、隣接するターミナル間及びターミナル、アース間に、DC 250Vを印加し測定する。 (JIS C5402 5.2/MIL-STD-202 試験法 302)  Mate connectors and apply 250V DC between adjacent terminal or ground. (JIS C5402 5.2/MIL-STD-202 Method 302)	500 Megohms MIN.
4-1-3	耐 電 圧 Dielectric Strength	コネクタを嵌合させ、隣接するターミナル間及びターミナル、アース間に、AC(rms) 500V (実効値) を1分間 印加する。感度電流 2mA (JIS C5402 5.1/MIL-STD-202 試験法 301)  Mate connectors and apply 500V AC(rms) for 1 minute between adjacent terminal or ground. Trip current 2mA. (JIS C5402 5.1/MIL-STD-202 Method 301)	異常なきこと No Breakdown
4-1-4	圧着部接触抵抗 Contact Resistance on Crimped Portion	ターミナルに適合電線を圧着し、開放電圧20mV以下、短絡電流 10mA にて測定する。  Crimp the applicable wire to the terminal, measured by dry circuit, 20mV MAX., 10mA.	5 milliohms MAX.

REVISE ON PC ONLY		TITLE:	
<b>J</b>	SEE SHEET 1 OF 16	1.5mm PITCH WIRE TO BOARD CONNECTOR SINGLE DIP R/A TYPE	
		<b>製品仕様書</b>	
REV.	DESCRIPTION	THIS DOCUMENT CONTAINS INFORMATION THAT IS PROPRIETARY TO MOLEX INC. AND SHOULD NOT BE USED WITHOUT WRITTEN PERMISSION	
DOCUMENT NUMBER <b>PS-503175-001</b>		FILE NAME PS-503175-001.docx	SHEET 3 OF 16
EN-037(2015-09 rev.4)			

4-2. 機械的性能 Mechanical Performance

項目 Item		条件 Test Condition		規格 Requirement
4-2-1	挿入力及び抜去力 Insertion and Withdrawal Force	手挿抜にて挿入、抜去を行う。 Insert and withdraw connectors with hand.		第6項参照 Refer to paragraph 6
4-2-2	圧着部引張強度 Crimping Pull out Force	圧着されたターミナルを治具に 固定し、電線を軸方向に 毎分25±3mmの速さで引張る。 (JIS C5402 6.8)  Fix the crimped terminal, apply axial pull out force on the wire at the speed rate of 25±3mm/minute. (JIS C5402 6.8)	AWG#24	29.4N{3.0kgf}MIN.
			AWG#26	19.6N{2.0kgf}MIN.
			AWG#28	9.8N{1.0kgf}MIN.
			AWG#30	4.9N{0.5kgf}MIN.
4-2-3	ターミナル挿入力 Terminal Insertion Force	圧着されたターミナルをハウジングに挿入する。 Insert the crimped terminal into the housing.		9.8N { 1.0kgf } MAX.
4-2-4	プラグターミナル 保持力 Plug Terminal Retention Force	プラグハウジングに装着されたプラグターミナルを 毎分 25±3mm の速さで引張る。  Apply axial pull out force at the speed rate of 25±3mm/minute on the plug terminal assembled in the plug housing.		9.8N { 1.0kgf } MIN.
4-2-5	リセターミナル 保持力 Rec. Terminal Retention Force	リセハウジングに装着されたターミナルを 毎分 25±3mm の速さで軸方向に引張る。  Apply axial pull out force at the speed rate of 25±3mm/minute on the rec. terminal assembled in the rec. housing.		2.94N {0.3 kgf} MIN.
4-2-6	ハウジングロック強度 (ポジティブロック) Housing Lock Strength ( Positive Lock )	ハウジングを嵌合し、軸方向に毎分25±3mmの 速さで引張る。  Mated connectors, and apply axial pull out force at the speed rate of 25±3mm/minute.		19.6N {2.0 kgf} MIN.

REVISE ON PC ONLY		TITLE: 1.5mm PITCH WIRE TO BOARD CONNECTOR SINGLE DIP R/A TYPE <b>製品仕様書</b>
<b>J</b>	SEE SHEET 1 OF 16	
REV.	DESCRIPTION	THIS DOCUMENT CONTAINS INFORMATION THAT IS PROPRIETARY TO MOLEX INC. AND SHOULD NOT BE USED WITHOUT WRITTEN PERMISSION

DOCUMENT NUMBER  
**PS-503175-001**

FILE NAME  
PS-503175-001.docx

SHEET  
4 OF 16

## 4-3. その他 Environmental Performance and Others

項目 Item		条件 Test Condition	規格 Requirement	
4-3-1	挿抜寿命 Repeated Insertion / Withdrawal	1分間 10回 以下の速さで、手挿抜にて挿入、抜去を30回 繰返す。 When mated up to 30 cycles repeatedly by the rate of 10 cycles per minute with hand.	接触抵抗 Contact Resistance	40 milliohms MAX.
4-3-2	温度上昇 Temperature Rise	コネクタを嵌合させ、最大許容電流を通電しコネクタの温度上昇分を測定する。 (UL 498) Carrying rated current load. (UL 498)	温度上昇 Temperature Rise	30 °C MAX.
4-3-3	耐振動性 Vibration	DC 1mA 通電状態にて、嵌合軸を含む互いに垂直な3方向に 掃引割合10~55~10 Hz/分、全振幅 1.52mm の振動を各2時間 加える。 (MIL-STD-202 試験法 201) Mate connectors and subject to the following vibration conditions, for a period of 2 hours in each of 3 mutually perpendicular axes, passing DC 1mA during the test. Amplitude : 1.52mm P-P Frequency : 10~55~10 Hz in 1 minute. Duration : 2 hours in each X.Y.Z.axes. (MIL-STD-202 Method 201)	外観 Appearance	異常なきこと No Damage
			接触抵抗 Contact Resistance	40 milliohms MAX.
			瞬断 Discontinuity	1 microsecond MAX.
4-3-4	耐衝撃性 Mechanical Shock	DC 1mA 通電状態にて、嵌合軸を含む互いに垂直な 6方向 に 490m/s <sup>2</sup> {50G}、作用時間 11msの衝撃を 各3回 加える。 (JIS C0041/MIL-STD-202 試験法 213) Mate connectors and subject to the following shock conditions. 3 shocks shall be applied along 3 mutually perpendicular axes, passing DC 1 mA current during the test. (Total of 18 shocks) Test pulse : Half Sine Peak value : 490 m/s <sup>2</sup> (50 G) Duration : 11 ms (JIS C0041/MIL-STD-202 Method 213)	外観 Appearance	異常なきこと No Damage
			接触抵抗 Contact Resistance	40 milliohms MAX.
			瞬断 Discontinuity	1 microsecond MAX.

REVISE ON PC ONLY

**J**

SEE SHEET 1 OF 16

TITLE:

 1.5mm PITCH WIRE TO BOARD CONNECTOR  
SINGLE DIP R/A TYPE

**製品仕様書**

THIS DOCUMENT CONTAINS INFORMATION THAT IS PROPRIETARY TO MOLEX INC. AND SHOULD NOT BE USED WITHOUT WRITTEN PERMISSION

REV.

DESCRIPTION

 DOCUMENT NUMBER  
**PS-503175-001**

FILE NAME

PS-503175-001.docx

SHEET

5 OF 16

項 目 Item		条 件 Test Condition	規 格 Requirement	
4-3-5	耐 熱 性 Heat Resistance	コネクタを嵌合させ、105±2°C の雰囲気中に96時間放置後取り出し、1時間室温に放置する。 (JIS C60068-2-2/MIL-STD-202 試験法 108)  Mate connectors and expose to 105±2°C for 96 hours. Upon completion of the exposure period, the test specimens shall be conditioned at ambient room conditions for 1 hour , after which the specified measurements shall be performed. (JIS C60068-2-2/MIL-STD-202 Method 108)	外 観 Appearance	異常なきこと No Damage
			接 触 抵 抗 Contact Resistance	40 milliohms MAX
4-3-6	耐 寒 性 Cold Resistance	コネクタを嵌合させ、-40±3°C の雰囲気中に96時間 放置後取り出し、1時間 室温に放置する。(JIS C60068-2-1)  Mate connectors and expose to -40±3°C for 96 hours. Upon completion of the exposure period, the test specimens shall be conditioned at ambient room conditions for 1 hour, after which the specified measurements shall be performed. (JIS C60068-2-1)	外 観 Appearance	異常なきこと No Damage
			接 触 抵 抗 Contact Resistance	40 milliohms MAX.
4-3-7	耐 湿 性 Humidity	コネクタを嵌合させ、40±2°C、相対湿度90~95% の雰囲気中に 96時間 放置後取り出し、1時間 室温に放置する。 (JIS C60068-2-3/MIL-STD-202 試験法 103)  Mate connectors and expose to 40±2°C, relative humidity 90 to 95% for 96 hours. Upon completion of the exposure period, the test specimens shall be conditioned at ambient room conditions for 1 to 2 hours, after which the specified measurements shall be performed. (JIS C60068-2-3/MIL-STD-202 Method 103)	外 観 Appearance	異常なきこと No Damage
			接 触 抵 抗 Contact Resistance	40 milliohms MAX.
			絶 縁 抵 抗 Insulation Resistance	100 Megohm MIN.
			耐 電 圧 Dielectric Strength	4-1-3項満足のこと Must meet 4-1-3

REVISE ON PC ONLY

**J**

SEE SHEET 1 OF 16

TITLE:

1.5mm PITCH WIRE TO BOARD CONNECTOR  
SINGLE DIP R/A TYPE

**製品仕様書**

THIS DOCUMENT CONTAINS INFORMATION THAT IS PROPRIETARY TO MOLEX INC. AND SHOULD NOT BE USED WITHOUT WRITTEN PERMISSION

REV.

DESCRIPTION

DOCUMENT NUMBER  
**PS-503175-001**

FILE NAME

PS-503175-001.docx

SHEET

6 OF 16

項 目 Item		条 件 Test Condition	規 格 Requirement	
4-3-8	温度サイクル Temperature Cycling	コネクタを嵌合させ、 $-40\pm 3^{\circ}\text{C}$ に 30分、 $+105\pm 2^{\circ}\text{C}$ に 30分 これを1サイクルとし、5サイクル 繰返す。 但し、温度移行時間は 5分以内 とする。 試験後1~2時間 室温に放置する。 (JIS C0025)  Mate connectors and subject to the following conditions for 5 cycles. Upon completion of the exposure period, the test specimens shall be conditioned at ambient room conditions for 1 to 2hours, after which the specified measurements shall be performed. 5 cycles of : a) $-40\pm 3^{\circ}\text{C}$ 30 minutes b) $+105\pm 2^{\circ}\text{C}$ 30 minutes (JIS C0025)	外 観 Appearance	異常なきこと No Damage
			接 触 抵 抗 Contact Resistance	40 milliohms MAX.
4-3-9	塩 水 噴 霧 Salt Spray	コネクタを嵌合させ、 $35\pm 2^{\circ}\text{C}$ にて $5\pm 1\%$ 重量比の塩水を $48\pm 4$ 時間噴霧し、試験後常温で水洗いした後、室温で乾燥させる。 (JIS C60068-2-11/MIL-STD-202 試験法101)  Mate connectors and expose to the following salt mist conditions. Upon completion of the exposure period, salt deposits shall be removed by a gentle wash or dip in running water, after which the specified measurements shall be performed. NaCl solution Concentration                      : $5\pm 1\%$ Spray time                            : $48\pm 4$ hours Ambient temperature : $35\pm 2^{\circ}\text{C}$ (JIS 60068-2-11/MIL-STD-202 Method 101)	外 観 Appearance	著しいサビの なきこと。 No Damage
			接 触 抵 抗 Contact Resistance	40 milliohms MAX.
4-3-10	耐亜硫酸ガス SO <sub>2</sub> Gas	コネクタを嵌合させ、 $40\pm 2^{\circ}\text{C}$ にて $50\pm 5\text{ppm}$ の亜硫酸ガス中に24時間放置する。  Mated connectors and expose to the conditions of $50\pm 5\text{ppm}$ SO <sub>2</sub> gas ambient temperature $40\pm 2^{\circ}\text{C}$ for 24 hours.	外 観 Appearance	異常なきこと No Damage
			接 触 抵 抗 Contact Resistance	40 milliohms MAX.

REVISE ON PC ONLY

**J**

SEE SHEET 1 OF 16

TITLE:

1.5mm PITCH WIRE TO BOARD CONNECTOR  
SINGLE DIP R/A TYPE

**製品仕様書**

REV.

DESCRIPTION

THIS DOCUMENT CONTAINS INFORMATION THAT IS PROPRIETARY TO MOLEX INC. AND SHOULD NOT BE USED WITHOUT WRITTEN PERMISSION

DOCUMENT NUMBER  
**PS-503175-001**

FILE NAME  
PS-503175-001.docx

SHEET  
7 OF 16

項 目 Item		条 件 Test Condition	規 格 Requirement	
4-3-11	耐アンモニア性 Ammonia gas	コネクタを嵌合させ、濃度28%のアンモニア水を入れた容器中に40分間放置する。 (1Lに対して25mLの割合)  Mated connectors and expose to the conditions of NH3 gas evaporating from 28% Ammonia solution for 40 minutes.	外 観 Appearance	割れ、ヒビ等の 破損なきこと without damage such as cracks or other breaks
			接 触 抵 抗 Contact Resistance	40 milliohms MAX.
4-3-12	半田付け性 Solderability	ターミナルまたはピンをフラックスに浸し、本体の取付け基準面より1.6mm迄、245±3°Cの半田に3±0.5秒浸す。  Soldering Time : 3±0.5 sec. Solder Temperature: 245±3°C	濡れ性 Solder Wetting	浸漬面積の 90%以上 90% of immersed area must show no voids, pin holes.
4-3-13	半田耐熱性 Resistance to Soldering Heat	ディップの場合 <u>Soldering bath method</u> ターミナルまたはピンを本体の取付け基準面より1.6mm迄、260±5°Cの半田に5±0.5秒浸す。 Soldering Time : 5±0.5 sec. Solder Temperature: 260±5°C	外 観 Appearance	端子ガタ、割れ等 異状なきこと No Damage
		(手半田時) <u>Soldering iron method</u> 370~400°Cの半田ゴテにて最大5秒加熱する。但し、端ピンに異常な加圧のないこと。  Solder Time : 5 sec. MAX. Solder Temperature: 370~400°C However, without too much pressure to the terminal pin		

( ) :参考規格 Reference Standard  
{ } :参考単位 Reference Unit

REVISE ON PC ONLY		TITLE:	
<b>J</b>	SEE SHEET 1 OF 16	1.5mm PITCH WIRE TO BOARD CONNECTOR SINGLE DIP R/A TYPE	
		<b>製品仕様書</b>	
REV.	DESCRIPTION	THIS DOCUMENT CONTAINS INFORMATION THAT IS PROPRIETARY TO MOLEX INC. AND SHOULD NOT BE USED WITHOUT WRITTEN PERMISSION	
DOCUMENT NUMBER <b>PS-503175-001</b>		FILE NAME PS-503175-001.docx	SHEET 8 OF 16
EN-037(2015-09 rev.4)			



【 5. 外觀形状、寸法及び材質 PRODUCT SHAPE, DIMENSIONS AND MATERIALS 】

- 1. 製品寸法 Dimensions of product  
     図面参照 Refer to the drawing.

<b>J</b>	REVISE ON PC ONLY	SEE SHEET 1 OF 16	TITLE: 1.5mm PITCH WIRE TO BOARD CONNECTOR SINGLE DIP R/A TYPE	
	REV.		DESCRIPTION	製品仕様書
DOCUMENT NUMBER <b>PS-503175-001</b>			FILE NAME PS-503175-001.docx	SHEET 9 OF 16
EN-037(2015-09 rev.4)				

**【 6. 挿入力及び抜去力 INSERTION / WITHDRAWAL FORCE 】**

極 数 No. of CKT	単位 UNIT	挿入力 (最大値) Insertion (MAX.)			抜去力 (最小値) Withdrawal (MIN.)		
		初回 1st	6 回目 6th	30 回目 30th	初回 1st	6 回目 6th	30 回目 30th
2	N {kgf}	6.5 { 0.66 }	7.0 { 0.72 }	11.0 { 1.12 }	0.4 { 0.04 }	0.4 { 0.04 }	0.4 { 0.04 }
3	N {kgf}	9.7 { 0.99 }	10.5 { 1.07 }	15.1 { 1.54 }	0.6 { 0.06 }	0.6 { 0.06 }	0.6 { 0.06 }
4	N {kgf}	12.9 { 1.32 }	14.0 { 1.43 }	18.3 { 1.87 }	0.8 { 0.08 }	0.8 { 0.08 }	0.8 { 0.08 }
5	N {kgf}	16.2 { 1.65 }	17.5 { 1.79 }	21.8 { 2.22 }	1.0 { 0.10 }	1.0 { 0.10 }	1.0 { 0.10 }
6	N {kgf}	19.4 { 1.98 }	21.5 { 2.20 }	24.8 { 2.53 }	1.2 { 0.12 }	1.2 { 0.12 }	1.2 { 0.12 }
7	N {kgf}	22.6 { 2.31 }	24.5 { 2.50 }	28.6 { 2.92 }	1.4 { 0.14 }	1.4 { 0.14 }	1.4 { 0.14 }
8	N {kgf}	25.9 { 2.64 }	28.0 { 2.86 }	32.3 { 3.30 }	1.6 { 0.16 }	1.6 { 0.16 }	1.6 { 0.16 }
9	N {kgf}	29.1 { 2.97 }	31.5 { 3.22 }	35.9 { 3.66 }	1.8 { 0.18 }	1.8 { 0.18 }	1.8 { 0.18 }
10	N {kgf}	32.3 { 3.30 }	35.4 { 3.61 }	39.4 { 4.02 }	2.0 { 0.20 }	2.0 { 0.20 }	2.0 { 0.20 }
11	N {kgf}	35.6 { 3.63 }	38.9 { 3.97 }	42.9 { 4.38 }	2.2 { 0.22 }	2.2 { 0.22 }	2.2 { 0.22 }
12	N {kgf}	38.8 { 3.96 }	42.5 { 4.33 }	46.3 { 4.72 }	2.4 { 0.24 }	2.4 { 0.24 }	2.4 { 0.24 }
13	N {kgf}	42.0 { 4.29 }	46.4 { 4.73 }	49.6 { 5.06 }	2.5 { 0.26 }	2.5 { 0.26 }	2.5 { 0.26 }
14	N {kgf}	45.3 { 4.62 }	49.6 { 5.06 }	52.8 { 5.39 }	2.7 { 0.28 }	2.7 { 0.28 }	2.7 { 0.28 }
15	N {kgf}	48.5 { 4.95 }	53.1 { 5.42 }	56.6 { 5.78 }	2.9 { 0.30 }	2.9 { 0.30 }	2.9 { 0.30 }

※ロックを解除して測定 Released lock, and measure.

{ } :参考単位 Reference Unit

REVISE ON PC ONLY		TITLE:	
<b>J</b>	SEE SHEET 1 OF 16	1.5mm PITCH WIRE TO BOARD CONNECTOR SINGLE DIP R/A TYPE	
		<b>製品仕様書</b>	
REV.	DESCRIPTION	THIS DOCUMENT CONTAINS INFORMATION THAT IS PROPRIETARY TO MOLEX INC. AND SHOULD NOT BE USED WITHOUT WRITTEN PERMISSION	
DOCUMENT NUMBER <b>PS-503175-001</b>		FILE NAME PS-503175-001.docx	SHEET 10 OF 16

【7. 注記 NOTES】

1. 本製品のプラスチック部に黒点、気泡等が確認される場合や色合いが異なる場合（経年変化によるハウジングの変色を含む）がありますが、製品性能に影響はありません。  
There is no influence in the product performance though the black spot or bubble etc. might be confirmed to the plastic part of this product and the shade might be different (discoloration by secular distortion etc.).
2. 本製品は錫めっきを使用しているため、外観に摺動痕がつく場合が御座いますが、製品性能に影響はありません。  
The wound of friction might adhere to externals because the tin plating is used for the tail and nail. But there is no influence in the product performance.
3. 本製品のハウジング及びメッキ表面に多少の傷が確認される場合がありますが、製品性能に問題ありません。  
A few scratch may be confirmed to the surface of the housing and the plating of this product, however, There is no problem in the product performance.
4. 環境指令への適合 COMPLIANCE WITH ENVIRONMENTAL DIRECTIVE  
ELV及びRoHS適合品  
ELV and RoHS Compliant
5. 本製品のプラスチック部に紫外線により変色する場合がありますが、製品性能に問題ありません。  
Discoloration of the plastic part of this product can result from exposure to ultraviolet light. There is no problem in the product performance.
6. 梱包品の推奨保管条件を超えた場合は外観、半田付け性を確認の上ご使用下さい。  
Please use it after confirming externals and soldering when the storage condition of packing goods is over recommended storage condition.

REVISE ON PC ONLY		TITLE:	
<b>J</b>	SEE SHEET 1 OF 16	1.5mm PITCH WIRE TO BOARD CONNECTOR SINGLE DIP R/A TYPE	
	REV.	DESCRIPTION	製品仕様書 THIS DOCUMENT CONTAINS INFORMATION THAT IS PROPRIETARY TO MOLEX INC. AND SHOULD NOT BE USED WITHOUT WRITTEN PERMISSION
DOCUMENT NUMBER <b>PS-503175-001</b>		FILE NAME PS-503175-001.docx	SHEET 11 OF 16
EN-037(2015-09 rev.4)			

【 8. 取り扱い上の注意事項 INSTRUCTION UPON USAGE 】

1. コネクタの詳細な取り扱いにつきましては、別紙の 1.5 W/B CONN. SINGLE のコネクタ取り扱い説明書 (AS-502578-001 日本版、AS-502578-002 英語版)を参照して下さい。  
Please refer to the manual of the 1.5 W/B connector. SINGLE series for the detailed handling of the connector. (AS-502578-001 Jananese version、AS-502578-002 English version)

- ① 嵌合時にリセハウジングの矢印で示す部位を押し嵌合して下さい。  
電線やハウジングのロック部を押した場合、これらが破損する恐れがありますのでお避け下さい。  
Please push the part directed by FIG.1 at the time of mate.  
It may damage, when electric wires or lock part of the receptacle housing are pushed.



図 1  
FIG.1

- ② コネクタの嵌合を取り外す際は、必ずロックを解除して行って下さい。  
電線はまとめて軽くつかみ、指の平全体で、ロック解除用バーをロック保護壁と共に押してロックを解除し、ゆっくり引き抜いてください。  
When unmated connectors, positive locks shall be released.

2. 弊社の推奨基板パターン寸法を変更して設計を行なう際は、致命的な不良の原因にもなりますのであらかじめご相談下さい。  
In the case of changing our recommended board pattern size and designing, please consult in advance because it may cause a fatal defect.

REVISE ON PC ONLY		TITLE:	
<b>J</b>	SEE SHEET 1 OF 16	1.5mm PITCH WIRE TO BOARD CONNECTOR SINGLE DIP R/A TYPE	
	REV.	DESCRIPTION	製品仕様書 THIS DOCUMENT CONTAINS INFORMATION THAT IS PROPRIETARY TO MOLEX INC. AND SHOULD NOT BE USED WITHOUT WRITTEN PERMISSION
DOCUMENT NUMBER <b>PS-503175-001</b>		FILE NAME PS-503175-001.docx	SHEET 12 OF 16
EN-037(2015-09 rev.4)			

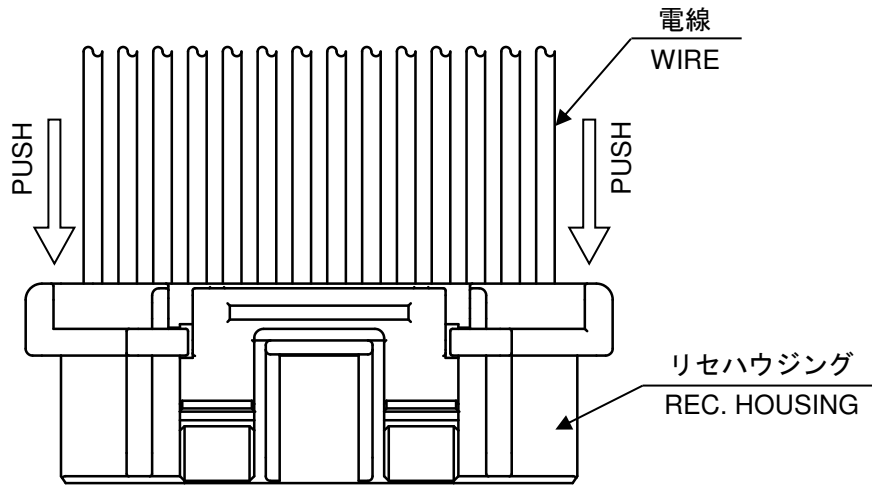
3. 平坦度の実装性能は、実装基板の反りの影響を含まないものと致します。  
Mounting performance of coplanarity shall not contain the influence of the warpage of the mounting board.
4. 本品の平坦度保証につきましては、実装前での保証のみであり、空リフロー中および空リフロー後での平坦度につきましては、保証の限りではありません。  
The coplanarity assurance of this product is a guarantee alone before mounting, and the coplanarity during and after the empty reflow is not guaranteed.
5. 実装後において手半田コテによるリペアーを行なう際は、必ず仕様書掲載の条件以内で行なって下さい。条件を超えて実施した場合、端子の抜け、接点ギャップの変化、モールドの変形、溶融等が原因により破損の原因になります。  
Please conduct it under the condition of the specifications when repairing by hand soldering iron after mounting. In the case of practicing beyond the condition, the backlash, the change in the contact gap, the deformation of the mold and the melting, etc. may cause a damage.
6. ディップ条件によっては端子メッキ部にヨリ等が発生する場合がありますが、製品性能には影響はございません。  
Strand, etc. may be generated on the terminal plating part according to the dip condition, however, there is no influence in the product performance.
7. ディップ条件によっては樹脂部に変色が発生する場合がありますが、製品性能には影響はございません。  
Discoloration may be generated in the resin part according to the dip condition, however, there is no influence in the product performance.
8. ディップ条件によっては色落ちする場合がありますので、あらかじめご確認下さい。  
Color fall may be generated according to the dip condition, please consult in advance.
9. 本製品をご使用時に取り付けられた電線・プリント基板の共振や、機器の回転構造や可動部分の動作によりコネクタ嵌合部（接点部）が常に動いてしまう状態での御使用は避けて下さい。接触部の摺動磨耗等による接触不良の原因となります。従って、機器内で電線・プリント基板を固定し、共振を抑える等の処置をお願い致します。  
Please do not use the connector in a condition where the wire, the printed circuit board, or the contact area is experiencing a sympathetic vibration of wires and printed circuit board, and constant movement of devices. This may cause a defect in the contact due to the contact area being worn down. Therefore, please fix wires and printed circuit board on the chassis, and reduces sympathetic vibration.

REVISE ON PC ONLY		TITLE:	
<b>J</b>	SEE SHEET 1 OF 16	1.5mm PITCH WIRE TO BOARD CONNECTOR SINGLE DIP R/A TYPE	
		<b>製品仕様書</b>	
REV.	DESCRIPTION	THIS DOCUMENT CONTAINS INFORMATION THAT IS PROPRIETARY TO MOLEX INC. AND SHOULD NOT BE USED WITHOUT WRITTEN PERMISSION	
DOCUMENT NUMBER <b>PS-503175-001</b>		FILE NAME PS-503175-001.docx	SHEET 13 OF 16
EN-037(2015-09 rev.4)			

- 1 0. 基板実装前後に端子に触らないでください。  
Please do not touch the terminals before or after reflowing the connector onto the printed circuit board.
- 1 1. コネクタ嵌合状態で基板の持ち運び等コネクタに負荷が掛かる作業は行わないようにしてください。コネクタ破損等の原因となる場合が有ります。  
Please do not do work that the load hangs in the connector like the carrying of the substrate etc. with the connector engages. There is a case where it causes the connector damage etc.
- 1 2. 基板実装後に基板を直接積み重ねない様に注意してください。  
Please do not stack the printed circuit board directly after mounted the connector on it.
- 1 3. 半田こてによる手修正を行なう際、過度の半田やフラックスを使用しないで下さい。半田上がりやフラックス上がりにより接触、機能不良に至る場合があります。  
When conducting manual repairs using a soldering iron, please do not use more solder and flux than needed. This may cause solder wicking and flux wicking issues, and it will eventually cause a contact defect and functional issues.
- 1 4. 実装機によってコネクタに負荷が加わると変形、破損する場合がありますので事前にご確認下さい。  
If there is accidental contact with the connector while it is going through the reflow machine, there may be deformation or damage caused to the connector. Please check to prevent this.
- 1 5. コネクタのみで基板を支えることは避け、コネクタ以外での基板固定対策を行ってください。  
Please do not use the connector alone to provide mechanical support for the printed circuit board (PCB). Please ensure that there is a fixed structure on the phone chassis or other component support for the PCB.
- 1 6. 嵌合後、コネクタピッチ方向、スパン方向及び回転方向への負荷がかかるような動作またはセットはしないでください。コネクタ破壊やはんだクラックを引き起こします。  
After mated the connector, please do not allow the printed circuit boards to apply pressure on the connector in either the pitch direction or the span direction. It may cause damage to the connector and may crack the soldering.
- 1 7. 本製品及び加工工程品（仕掛品）や加工品（ハーネス等）の梱包及び輸送・保管時にはコネクタに負荷が加わらないようご注意ください。変形、破損などの原因となり、コネクタの性能不良の原因となります。  
Please try to prevent any external forces or shock from being applied to the connector while the cable assembly is in process, when it is being packaged, or while it is in transportation. This may cause deformation and damage to the connector and cause a defect in the product's performance.
- 1 8. ハーネス加工品及びコネクタ嵌合後の電線の引き回しの際、引張りによる力が加わりますと、接点部、結線部（圧着部）やロック部（端子ロック部）が損傷を受け、接触不良の原因となります。電線の引回し配線をされる場合、コネクタに無理な外力が加わらないように、電線に緩みを持たせ、余裕を持たせる処置をして下さい。  
The cable assembly should not have a constant stress or pulling force applied on it when it is in the mated condition. This phenomenon may damage the contact area or wiring area (crimping). Therefore, when designing the wire positioning, please ensure that there is enough length of wire to avoid stress on the connector.

REVISE ON PC ONLY		TITLE:	
<b>J</b>	SEE SHEET 1 OF 16	1.5mm PITCH WIRE TO BOARD CONNECTOR SINGLE DIP R/A TYPE	
		<b>製品仕様書</b>	
REV.	DESCRIPTION	THIS DOCUMENT CONTAINS INFORMATION THAT IS PROPRIETARY TO MOLEX INC. AND SHOULD NOT BE USED WITHOUT WRITTEN PERMISSION	
DOCUMENT NUMBER <b>PS-503175-001</b>		FILE NAME PS-503175-001.docx	SHEET 14 OF 16
EN-037(2015-09 rev.4)			

19. コネクタに適用できる電線は、原則として錫メッキつき付軟銅撚り線です。その他の電線の使用については別途ご確認ください。  
The applicable wire for this connector, in principle, is tin-plated copper stranded wire. Please consult us and evaluate it in advance when using other wires.
20. プラグハウジング (502578-\*\*0\*) に端子 (502579-0\*00、503429-0000) を挿入する際、図2に示した正規の方向から端子が突き当たるまで挿入して下さい。又、挿入後軽く電線を引張って端子が抜け出さないか確認下さい。  
When inserting the terminal (502579-0\*00, 503429-0000) into the receptacle housing (502578-\*\*0\*), please ensure that the terminal is inserted completely and touches the end of the receptacle housing. Please insert the terminal in the correct direction as showing in figure 2. Also, please pull the wire lightly after inserting the terminal to ensure that the terminal is fully inserted and can not be pulled out.

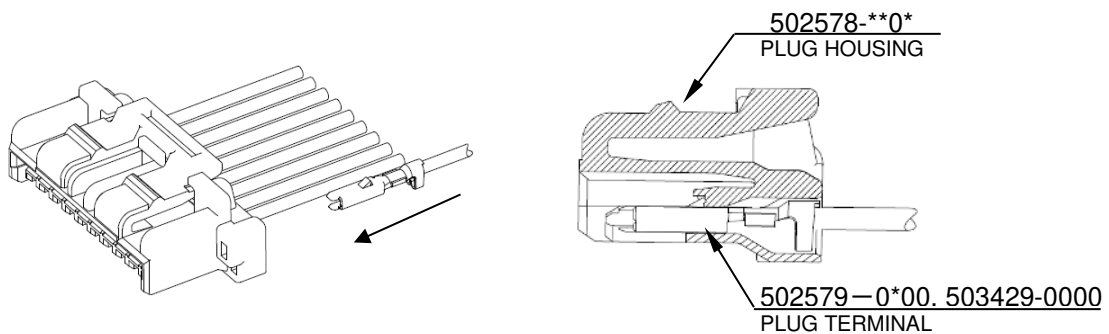

<図2 端子挿入方向>

<図3 端子装着状態>

21. 治具等を使用し、圧着端子を抜いた場合には、ランスが変形し強度が低下し端子を再装着後の端子保持力が極端に低下します。そのため、圧着端子のリペアの際には新しいハウジングを必ず使用して下さい。  
When extracting a crimp terminal from the housing using a jig, it may deform the housing lance and therefore reduce the terminal retention force after re-inserting of the terminal. Therefore, please ensure to use a new housing after repairing the crimp terminals.
22. 本製品をご使用時には、1 PIN当りの定格以上の電流を複数の回路に分岐しての使用は避けて下さい。  
When using this product, please ensure that the specification for rated current per circuit is followed. Do not allow the sum of the current used on several circuits to exceed the maximum allowable current.
23. 活電状態の電気回路で、挿入、抜去ができることを前提に作られていません。スパーク等による危険の発生、性能不良につながりますので、活電状態での挿入、抜去はしないで下さい。  
This product is not designed for the mating and unmating of the connectors to be performed under the condition of an active electrical circuit. It may cause a spark and product defect if the connectors are mated and unmated in this way.

REVISE ON PC ONLY		TITLE:	
<b>J</b>	SEE SHEET 1 OF 16	1.5mm PITCH WIRE TO BOARD CONNECTOR SINGLE DIP R/A TYPE	
		<b>製品仕様書</b>	
REV.	DESCRIPTION	THIS DOCUMENT CONTAINS INFORMATION THAT IS PROPRIETARY TO MOLEX INC. AND SHOULD NOT BE USED WITHOUT WRITTEN PERMISSION	
DOCUMENT NUMBER <b>PS-503175-001</b>		FILE NAME PS-503175-001.docx	SHEET 15 OF 16
EN-037(2015-09 rev.4)			

