



**Please note that Cypress is an Infineon Technologies Company.**

The document following this cover page is marked as “Cypress” document as this is the company that originally developed the product. Please note that Infineon will continue to offer the product to new and existing customers as part of the Infineon product portfolio.

**Continuity of document content**

The fact that Infineon offers the following product as part of the Infineon product portfolio does not lead to any changes to this document. Future revisions will occur when appropriate, and any changes will be set out on the document history page.

**Continuity of ordering part numbers**

Infineon continues to support existing part numbers. Please continue to use the ordering part numbers listed in the datasheet for ordering.



**AN INFINEON TECHNOLOGIES COMPANY**

**THIS SPEC IS OBSOLETE**

Spec No: 002-08493

Spec Title: S6AE101A ENERGY HARVESTING PMIC FOR  
WIRELESS SENSOR NODE

Replaced by: NONE

# Energy Harvesting PMIC for Wireless Sensor Node

The S6AE101A is a power management IC (PMIC) for energy harvesting that is built into circuits of solar cells connected in series, output power control circuits, output capacitor storage circuits, and power switching circuits of primary batteries. Super-low-power operation is possible using a consumption current of only 250 nA and startup power of only 1.2  $\mu$ W. As a result, even slight amounts of power generation can be obtained from compact solar cells under low-brightness environments of approximately 100 lx. The S6AE101A stores power generated by solar cells to an output capacitor using built-in switch control, and it turns on the power switching circuit while the capacitor voltage is within a preset maximum and minimum range for supplying energy to a load. If the power generated from solar cells is not enough, energy can also be supplied in the same way as solar cells from connected primary batteries for auxiliary power. Also, an over voltage protection (OVP) function is built into the input pins of the solar cells, and the open voltage of solar cells is used by this IC to prevent an overvoltage state. The S6AE101A is provided as a battery-free wireless sensor node solution that is operable by super-compact solar cells.

## Features

- Input power selection control: Solar cell or primary battery
- Operated by solar cells without the need for primary batteries
- Storage of energy from power supply to storage capacitors
- Output power gating control, output voltage regulation
- Operation input voltage range
  - Solar cell power : 2.0V to 5.5V
  - Primary battery power : 2.0V to 5.5V
- Adjustable output voltage range : 1.1V to 5.2V
- Low-consumption current : 250 nA
- Minimum input power at startup : 1.2  $\mu$ W
- Input overvoltage protection : 5.4V
- Compact SON-10 package : 3 mm  $\times$  3 mm

## Block Diagram

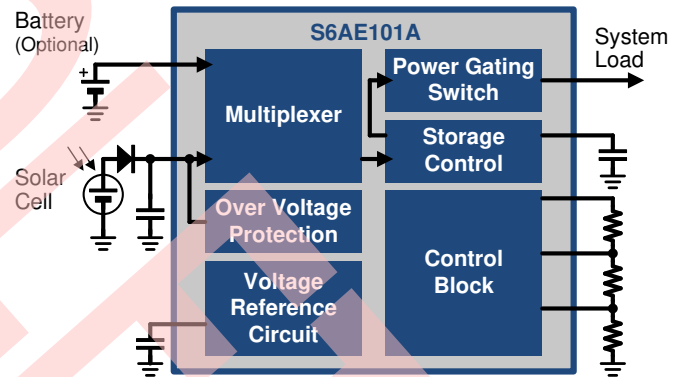

## Applications

- Energy harvesting power system with a very small solar cell
- Bluetooth® Smart sensor
- Wireless HVAC sensor
- Wireless lighting control
- Security system
- Smart home / Building / Industrial wireless sensor

## Contents

Features.....	1
Applications.....	1
Block Diagram.....	1
1. Pin Assignment.....	3
2. Pin Descriptions.....	3
3. Architecture Block Diagram.....	4
4. Absolute Maximum Ratings.....	5
5. Recommended Operating Conditions.....	5
6. Electrical Characteristics.....	6
7. Functional Description.....	7
7.1 Power Supply Control.....	7
7.2 Power Gating.....	14
7.3 Discharge.....	14
7.4 Over Voltage Protection (OVP Block).....	14
8. Application Circuit Example and Parts list.....	15
9. Application Note.....	16
9.1 Setting the Operation Conditions.....	16
9.2 PCB Layout.....	17
10. Development Support.....	17
11. Reference Data.....	18
12. Usage Precaution.....	20
13. RoHS Compliance Information.....	20
14. Ordering Information.....	20
15. Package Dimensions.....	21
16. Major Changes.....	22
Document History.....	22
Sales, Solutions, and Legal Information.....	23

## 1. Pin Assignment

Figure 1-1 Pin Assignment

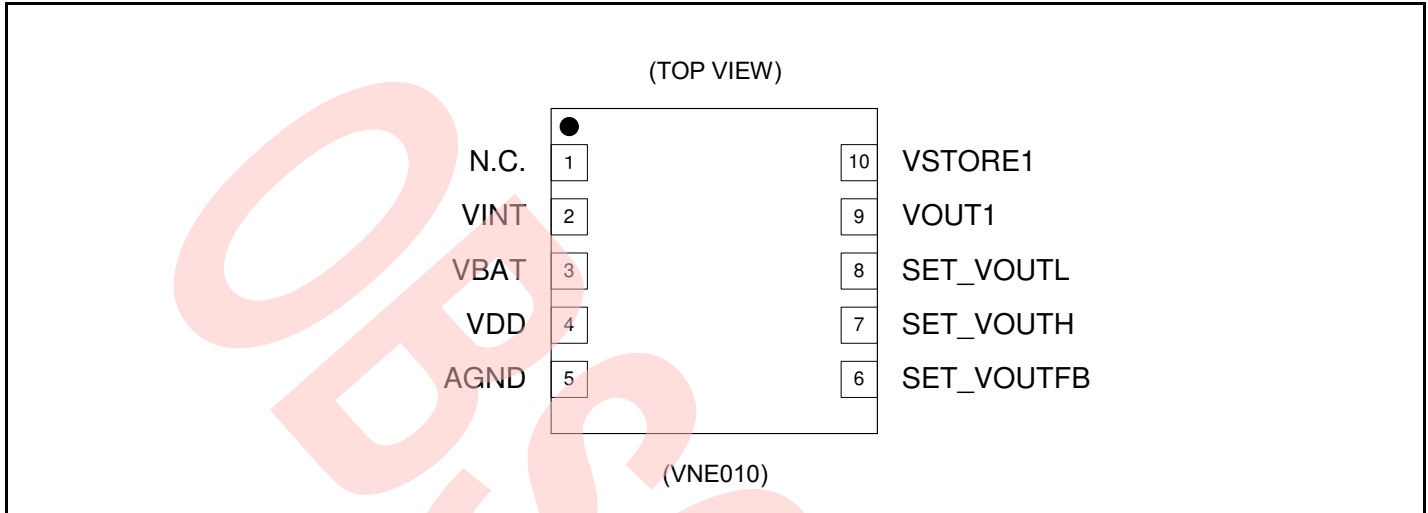

## 2. Pin Descriptions

Table 2-1 Pin Descriptions

Pin No.	Pin Name	I/O	Description
1	N.C	-	Non connection pin (Leave this pin open)
2	VINT	O	Internal circuit storage output pin
3	VBAT	I	Primary battery input pin (when being not used, leave this pin open )
4	VDD	I	Solar cell input pin (when being not used, leave this pin open )
5	AGND	-	Ground pin.
6	SET_VOUTFB	O	Reference voltage output pin (for connecting resistor)
7	SET_VOUTH	I	VOUT1 output voltage setting pin (for connecting resistor)
8	SET_VOUTL	I	VOUT1 output voltage setting pin (for connecting resistor)
9	VOUT1	O	Output voltage pin
10	VSTORE1	O	Storage output pin

Figure 2-1 I/O Pin Equivalent Circuit Diagram

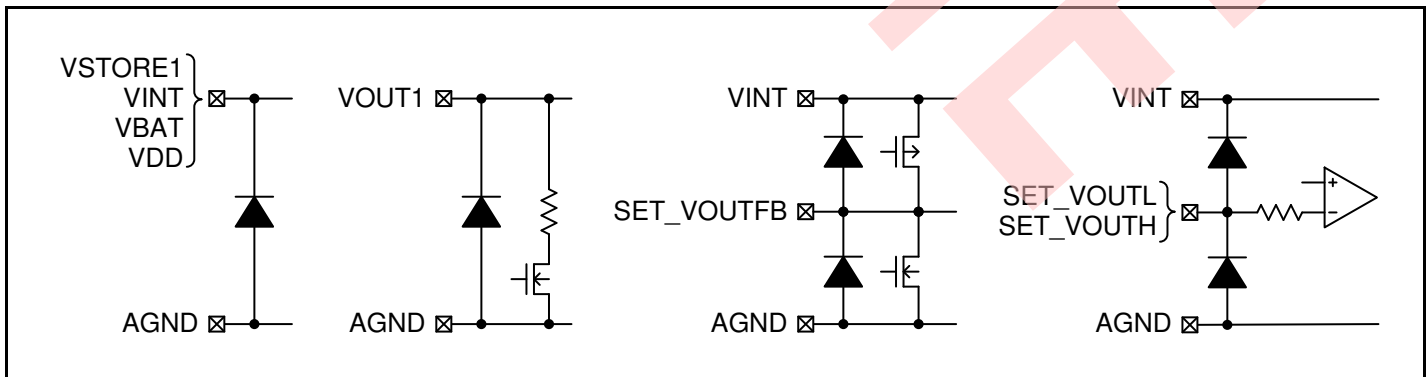

### 3. Architecture Block Diagram

Figure 3-1 Architecture Block Diagram

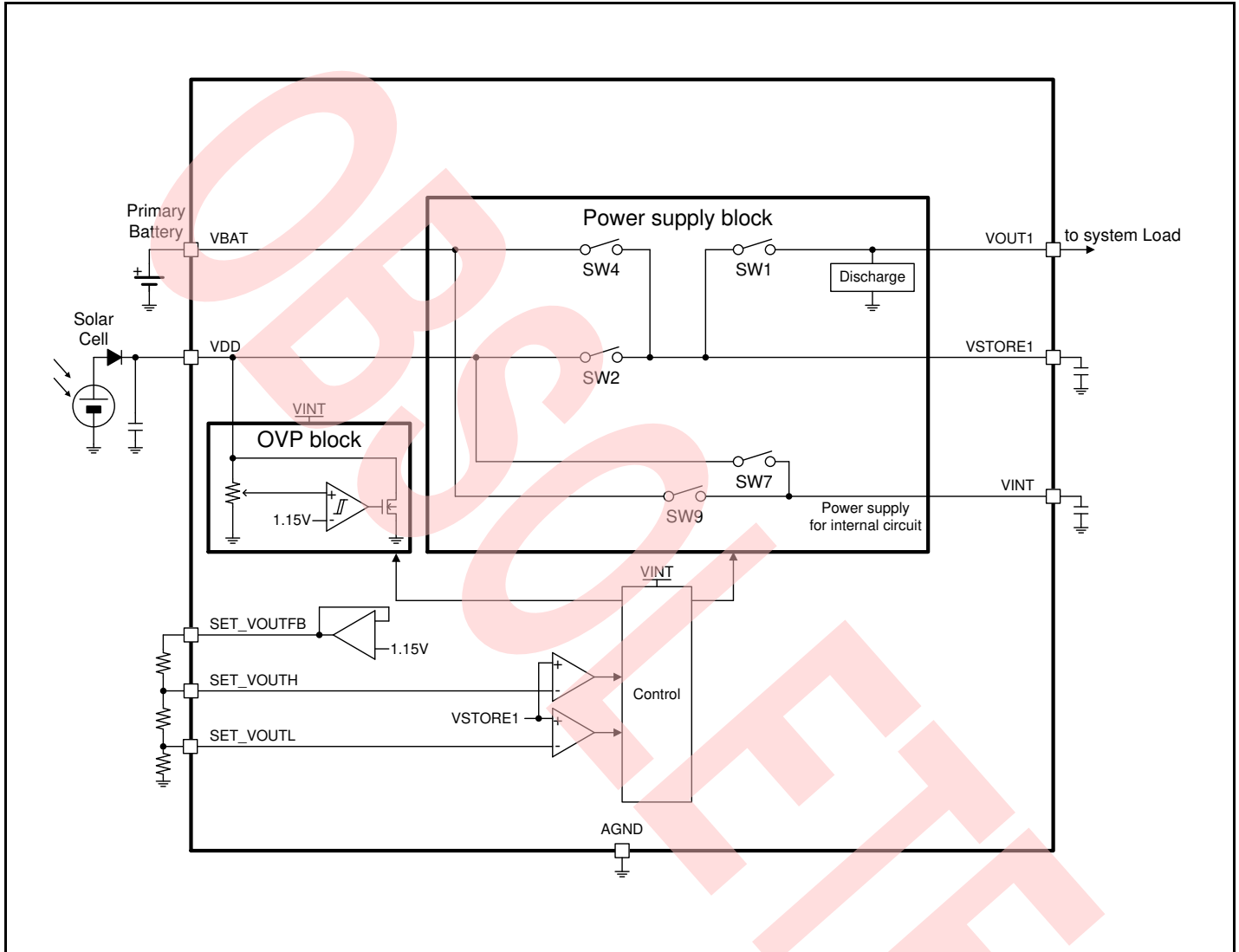

#### 4. Absolute Maximum Ratings

Parameter	Symbol	Condition	Rating		Unit
			Min	Max	
Power supply voltage (*1)	V <sub>MAX</sub>	VDD, VBAT pin	-0.3	+6.9	V
Signal input voltage(*1)	V <sub>INPUTMAX</sub>	SET_VOUTH, SET_VOUTL pin	-0.3	V <sub>VDD</sub>	V
VDD slew rate	V <sub>SLOPE</sub>	VDD pin	-	0.1	mV/μs
Power dissipation (*1)	P <sub>D</sub>	Ta ≤+ 25°C	-	1200 (*2)	mW
Storage temperature	T <sub>STG</sub>	-	-55	+125	°C

\*1: When GND=0V

\*2: θja (wind speed 0m/s): +58°C/W

**Warning:**

1. Semiconductor devices may be permanently damaged by application of stress (including, without limitation, voltage, current or temperature) in excess of absolute maximum ratings. Do not exceed any of these ratings.

#### 5. Recommended Operating Conditions

Parameter	Symbol	Condition	Value			Unit	
			Min	Typ	Max		
Power supply voltage 1 (*1)	V <sub>VDD</sub>	VDD pin	2.0	3.3	5.5	V	
Power supply voltage 2 (*1)	V <sub>VBAT</sub>	VBAT pin	2.0	3.0	5.5	V	
Signal input voltage (*1)	V <sub>INPUT</sub>	SET_VOUTH, SET_VOUTL pin	-	-	VINT pin voltage	V	
VOUT1 setting resistance	R <sub>VOUT</sub>	Sum of R1, R2, R3	10	-	50	MΩ	
VDD capacitance	C1	VDD pin	10	-	-	μF	
VINT capacitance	C2	VINT pin	1	-	-	μF	
VSTORE1 capacitance	C3	VSTORE1 pin	100	-	-	μF	
VOUT maximum setting voltage	V <sub>SYSH</sub>	VSTORE1 pin	1.3	-	5.2	V	
VOUT minimum setting voltage	V <sub>SYSL</sub>	VSTORE1 pin	V <sub>SYSH</sub> ≥ 1.7V	1.1	-	V <sub>SYSH</sub> × 0.90	V
			V <sub>SYSH</sub> < 1.7V	1.1	-	V <sub>SYSH</sub> × 0.85	V
Operating ambient temperature	Ta	-	-40	-	+85	°C	

\*1: When GND = 0V

**Warning:**

1. The recommended operating conditions are required in order to ensure the normal operation of the semiconductor device. All of the device's electrical characteristics are warranted when the device is operated under these conditions.
2. Any use of semiconductor devices will be under their recommended operating condition.
3. Operation under any conditions other than these conditions may adversely affect reliability of device and could result in device failure.
4. No warranty is made with respect to any use, operating conditions or combinations not represented on this data sheet. If you are considering application under any conditions other than listed herein, please contact sales representatives beforehand.

## 6. Electrical Characteristics

The electrical characteristics excluding the effect of external resistors and external capacitors are shown in below.

**Table 6-1 Electrical Characteristics (System Overall)**

(Unless specified otherwise, these are the electrical characteristics under the recommended operating environment.)

Parameter	Symbol	Condition	Value			Unit	
			Min	Typ	Max		
Minimum Input power in start-up	$W_{START}$	VDD pin, $T_a = +25^\circ\text{C}$ , $V_{VOUTH}$ setting =3V, By applying 0.4 $\mu\text{A}$ to VDD, when VOUT1 reaches $3\text{V} \times 95\%$ after the point when VDD reaches 3V.	-	-	1.2	$\mu\text{W}$	
Consumption current 1	$I_{QIN1}$	VDD pin input current, VDD=3V, Open VBAT pin, SW2 = OFF, $T_a = +25^\circ\text{C}$ , SET_VOUTFB resistance = 50 M $\Omega$ , VOUT1 Load = 0 mA	-	250	390	nA	
Power detection voltage	$V_{DETH}$	VDD, VBAT, VINT pin	1.0	1.4	2.0	V	
Power undetection voltage	$V_{DETL}$	VDD, VBAT, VINT pin	0.9	1.3	1.9	V	
Power detection hysteresis	$V_{DETHYS}$	VDD, VBAT, VINT pin	-	0.1	-	V	
VOUT maximum voltage	$V_{VOUTH}$	VSTORE1 pin, VOUT1 Load=0 mA	$V_{SYSH} \geq 2\text{V}$	$V_{SYSH} \times 0.950$	$V_{SYSH}$	$V_{SYSH} \times 1.050$	V
			$V_{SYSH} < 2\text{V}$	$V_{SYSH} \times 0.935$	$V_{SYSH}$	$V_{SYSH} \times 1.065$	V
Input power reconnect voltage	$V_{VOUTM}$	VSTORE1 pin, VOUT1 Load=0 mA	$V_{SYSH} \geq 2\text{V}$	$V_{VOUTH} \times 0.90250$	$V_{VOUTH} \times 0.95$	$V_{VOUTH} \times 0.99750$	V
			$V_{SYSH} < 2\text{V}$	$V_{VOUTH} \times 0.88825$	$V_{VOUTH} \times 0.95$	$V_{VOUTH} \times 1.01175$	V
VOUT minimum voltage	$V_{VOUTL}$	VSTORE1 pin, VOUT1 Load=0 mA	$V_{SYSL} \geq 2\text{V}$	$V_{SYSL} \times 0.950$	$V_{SYSL}$	$V_{SYSL} \times 1.050$	V
			$V_{SYSL} < 2\text{V}$	$V_{SYSL} \times 0.935$	$V_{SYSL}$	$V_{SYSL} \times 1.065$	V
OVP detection voltage	$V_{OVPH}$	VDD pin	5.2	5.4	5.5	V	
OVP release voltage	$V_{OVPL}$	VDD pin	5.1	5.3	5.4	V	
OVP detection hysteresis	$V_{OVPHYS}$	VDD pin	-	0.1	-	V	
OVP protection current	$I_{OVP}$	VDD pin input current	6	-	-	mA	

**Table 6-2 Electrical Characteristics (Switch)**

$V_{DD} \geq 3\text{V}$ ,  $V_{BAT} \geq 3\text{V}$ ,  $V_{INT} \geq 3\text{V}$ ,  $V_{VOUTL} \geq 3\text{V}$ ,  $V_{STORE1} \geq V_{VOUTL}$

(Unless specified otherwise, these are the electrical characteristics under the recommended operating environment.)

Parameter	Symbol	Condition	Value			Unit
			Min	Typ	Max	
On resistance 1	$R_{ON1}$	SW1, In connection of VSTORE1 pin and VOUT1 pin	-	1.5	2.5	$\Omega$
On resistance 2	$R_{ON2}$	SW2, In connection of VDD pin and VSTORE1 pin	-	5	10	k $\Omega$
On resistance 4	$R_{ON4}$	SW4, In connection of VDD pin and VSTORE1 pin	-	5	10	k $\Omega$
Discharge resistance	$R_{DIS}$	VOUT1 pin	-	1	2	k $\Omega$



## 7. Functional Description

### 7.1 Power Supply Control

This IC can operate by two input power supplies, namely, the solar cell voltage VDD and the primary battery voltage VBAT. The voltages at the VDD pin and VBAT pin are monitored, and selection control of the input power supply is performed based on this voltage state (Figure 7-1).

The input power (solar cell or primary battery) is temporarily stored to a capacitor connected to the VSTORE1 pin. When the voltage of the VSTORE1 pin reaches a certain threshold value or higher, the power switching switch (SW1) connects VSTORE1 and VOUT1.

**Table 7-1 Input Power Supply Selection Control**

VDD Voltage (Solar Cell)	VBAT Voltage (Primary Battery)	Operation
$V_{DETH}$ (1.55V) or higher	$V_{DETH}$ (1.55V) or higher	VDD input power supply is performed
	$V_{DETL}$ (1.45V) or less	VDD input power supply is performed
$V_{DETL}$ (1.45V) or less	$V_{DETH}$ (1.55V) or higher	VBAT input power supply is performed
	$V_{DETL}$ (1.45V) or less	All paths are disconnected

**Figure 7-1 Input Power Selection Control**

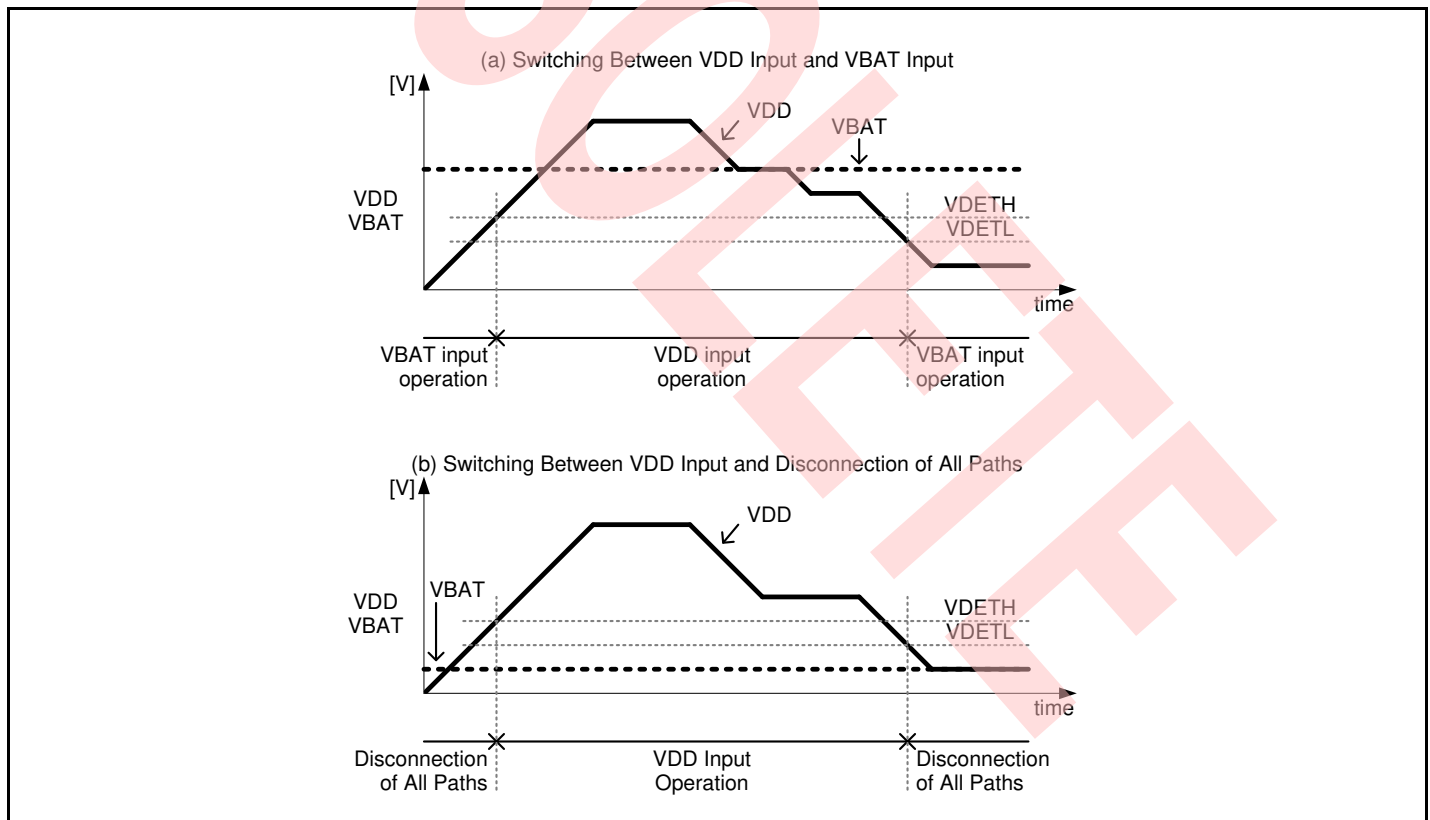

## 1. VDD input voltage operation

This section describes operation when the VDD pin is set as the input power (Figure 7-2).

- [1] When the voltage of the VDD pin reaches the power detection voltage ( $V_{DETH} = 1.55V$ ) or higher, the switch (SW2) connects VDD and VSTORE1 (path S1). Also, when the voltage of the VDD pin falls to the power undetection voltage ( $V_{DETL} = 1.45V$ ) or less, SW2 disconnects the path S1.
- [2] When the voltage of the VSTORE1 pin reaches the threshold value ( $V_{VOUTH}$ ) or higher that was set by the SET\_VOUTH pin, SW2 disconnects the path S1. Also, the VOUT switch (SW1) connects VSTORE1 and VOUT1 (path S2).
- [3] When the voltage of the VSTORE1 pin falls to the input power reconnect voltage ( $V_{VOUTM}$ ) or less, SW2 connects the path S1 (path S1+S2).
- [4] In addition, when the voltage falls to the threshold value ( $V_{VOUTL}$ ) or less that was set by the SET\_VOUTL pin, SW1 disconnects the path S2.
- [5] When SW1 disconnects the path S2, the discharge function is activated.

**Figure 7-2 VDD Pin Input Power Operation**

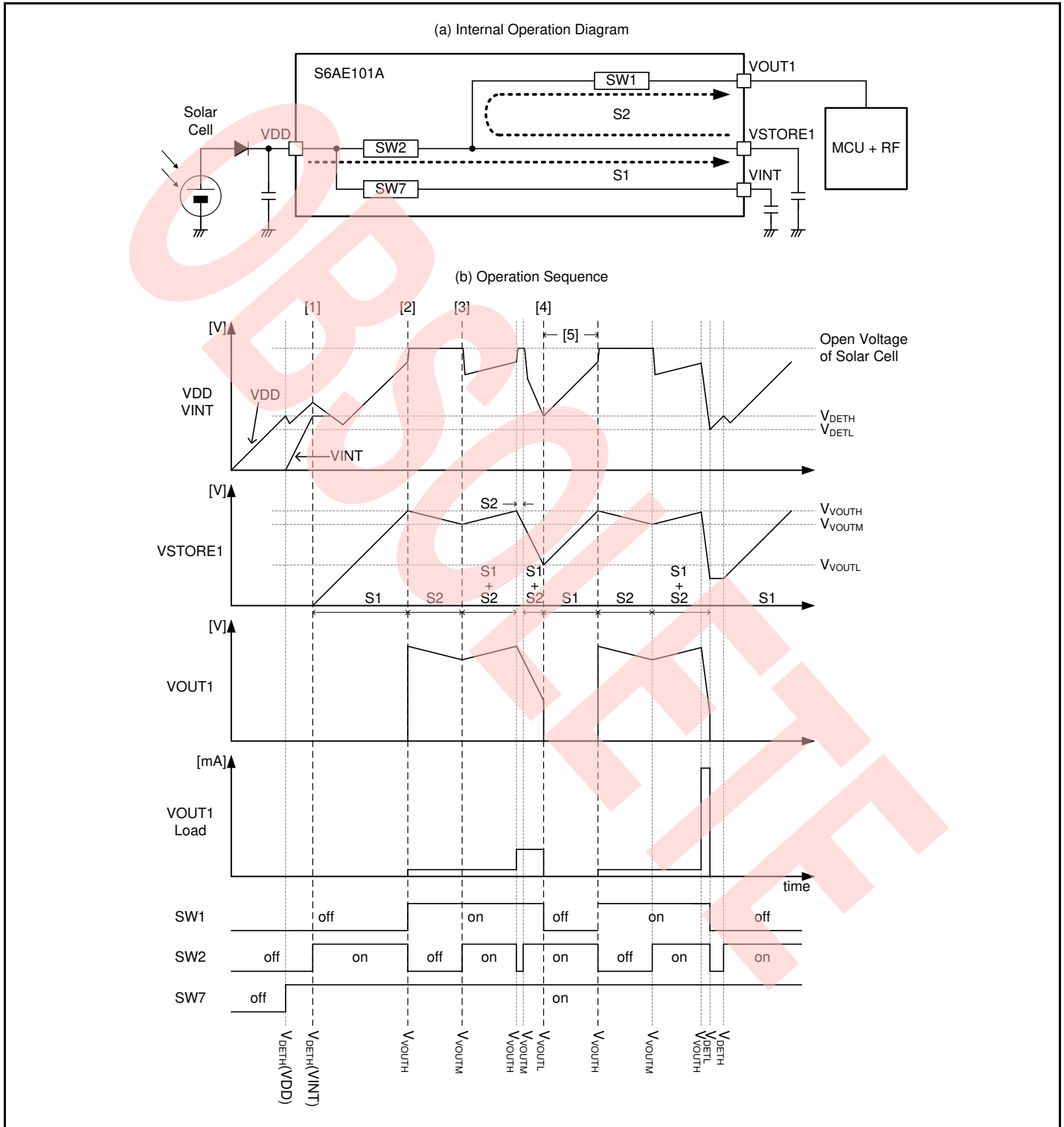

## 2. VBAT input voltage operation

This section describes operation when the VBAT pin is set as the input power (Figure 10-3).

- [1] When the voltage of the VBAT pin reaches the power detection voltage ( $V_{DETH} = 1.55V$ ) or higher, the switch (SW2) connects VBAT and VSTORE1 (path S3). Also, when the voltage of the VDD pin falls to the power undetection voltage ( $V_{DETL} = 1.45V$ ) or less, SW4 disconnects the path S3.
- [2] When the voltage of the VSTORE1 pin reaches the threshold value ( $V_{VOUTH}$ ) or higher that was set by the SET\_VOUTH pin, SW4 disconnects the path S3. Also, the VOUT switch (SW1) connects VSTORE1 and VOUT1 (path S2).
- [3] When the voltage of the VSTORE1 pin falls to the input power reconnect voltage ( $V_{VOUTM}$ ) or less, SW4 connects the path S3 (path S3+S2).
- [4] In addition, when the voltage falls to the threshold value ( $V_{VOUTL}$ ) or less that was set by the SET\_VOUTL pin, SW1 disconnects the path S2.
- [5] When SW1 disconnects the path S2, the discharge function is activated.

**Figure 7-3 VBAT Pin Input Power Operation**

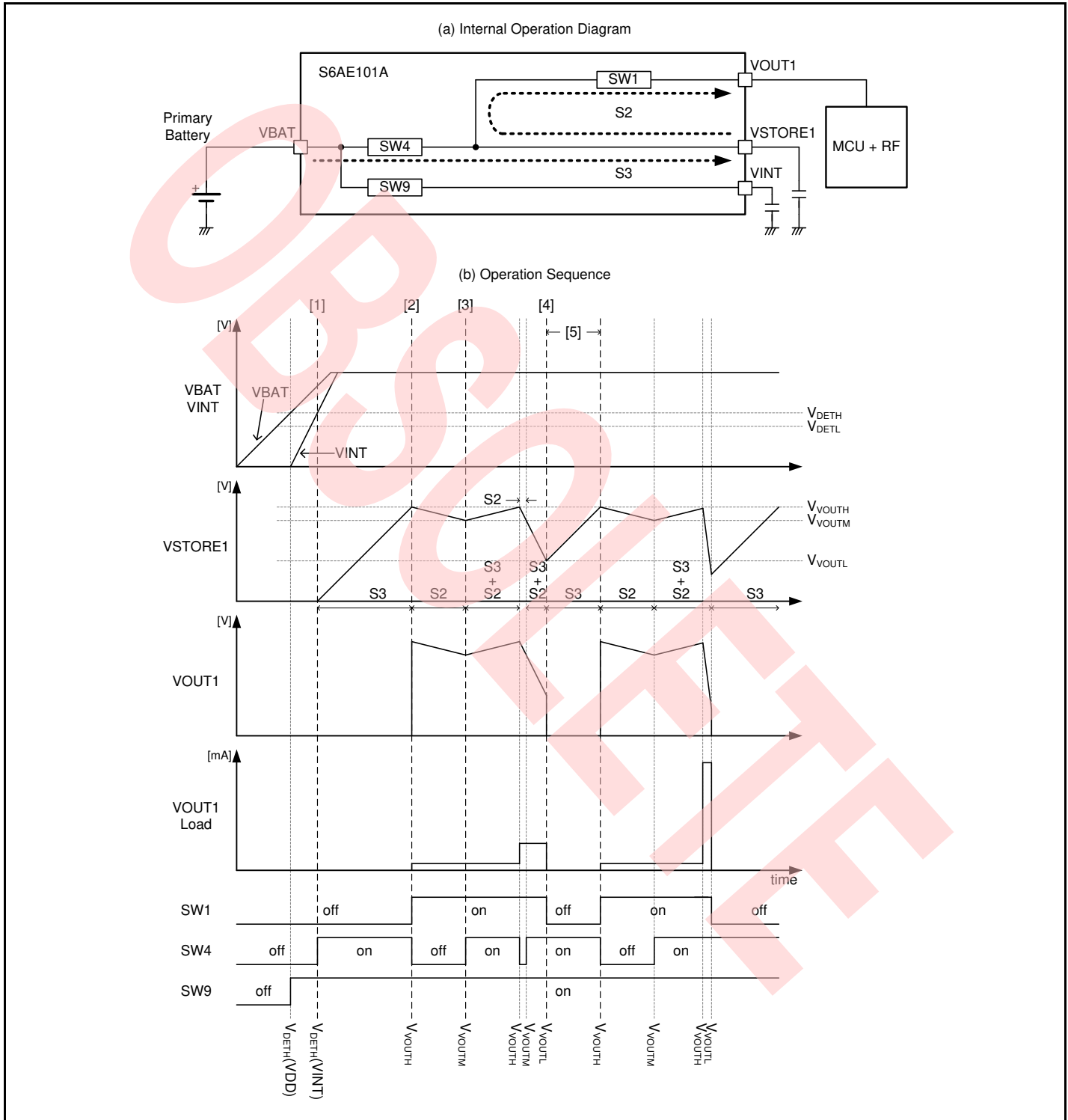

### 3. Input power supply switching

This section describes the input power switching operation (Figure 7-4).

- [1] If the voltages of the VDD pin and VBAT pin increase from a state where both are less than the power detection voltage ( $V_{DETH} = 1.55V$ ) so that the voltage of the VDD pin reaches the power detection voltage ( $V_{DETH} = 1.55V$ ) or higher, and operation switches to VDD input power operation back from the stage of disconnecting all paths.
- [2] When the voltage of the VBAT pin increases to the power detection voltage ( $V_{DETH} = 1.55V$ ) or higher, if the power from the solar cell is reduced, and when the voltage of the VDD pin falls to the power undetection voltage ( $V_{DETL} = 1.45V$ ) or less, operation switches from VDD input power operation to VBAT input power operation.
- [3] When the amount of power supplied from the solar cell increases, and the voltage of the VDD pin reaches the power detection voltage ( $V_{DETH} = 1.55V$ ) or higher, operation switches back to VDD input power operation. After switching, operation is performed based on VDD input power operation.

**Figure 7-4 Input Power Switching**

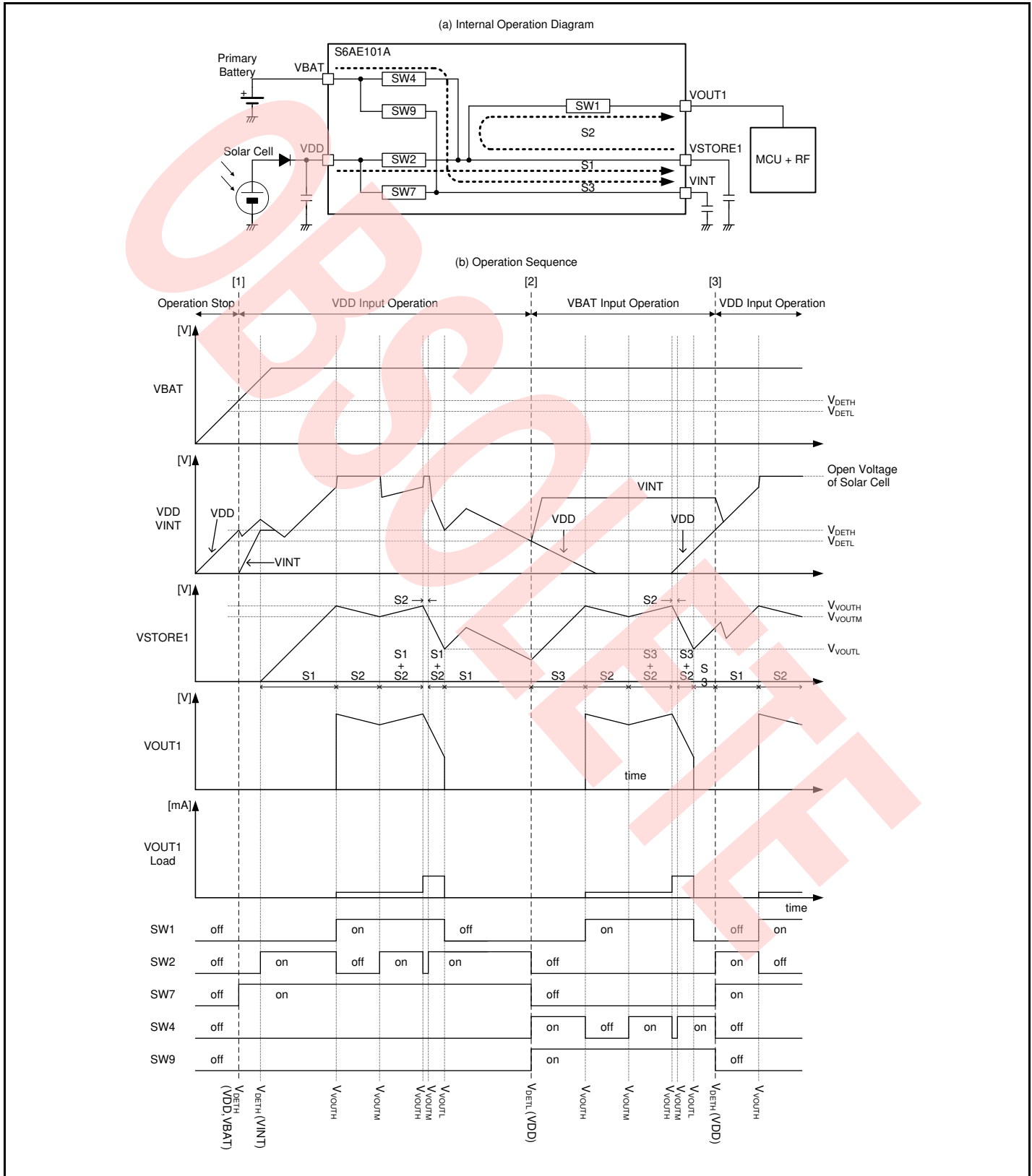

### 7.2 Power Gating

This IC has a power gating function for the external system. Once it is detected that the voltage of the VSTORE1 pin has reached the VOUT maximum voltage ( $V_{VOUTH}$ ), the VSTORE1 pin and VOUT pin are connected by an internal switch until the VOUT minimum voltage ( $V_{VOUTL}$ ) is reached.

Figure 7-5 Power Gating Operation

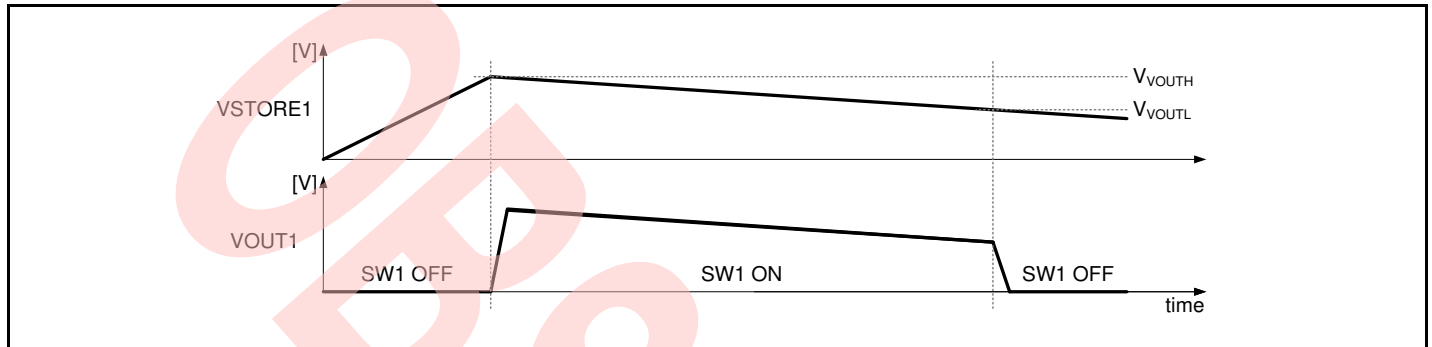

### 7.3 Discharge

This IC includes a VOUT1 pin discharge function.

When SW1 disconnects the VSTORE1 and VOUT1 path, the discharge circuit is activated between the VOUT1 pin and GND. The power of the VOUT1 pin is discharged to the GND level.

### 7.4 Over Voltage Protection (OVP Block)

This IC includes an input overvoltage protection (OVP) function for the VDD pin voltage.

When the VDD pin voltage reaches the OVP detection voltage ( $V_{OVPH}=5.4V$ ) or higher, the OVP current ( $I_{OVP}$ ) from the VDD pin is drawn in for limiting the increase in the VDD pin voltage for preventing damage to the IC. Also, when the OVP release voltage ( $V_{OVPL}=5.3V$ ) or less is reached, drawing-in of the OVP current is stopped.

Figure 7-6 OVP Operation

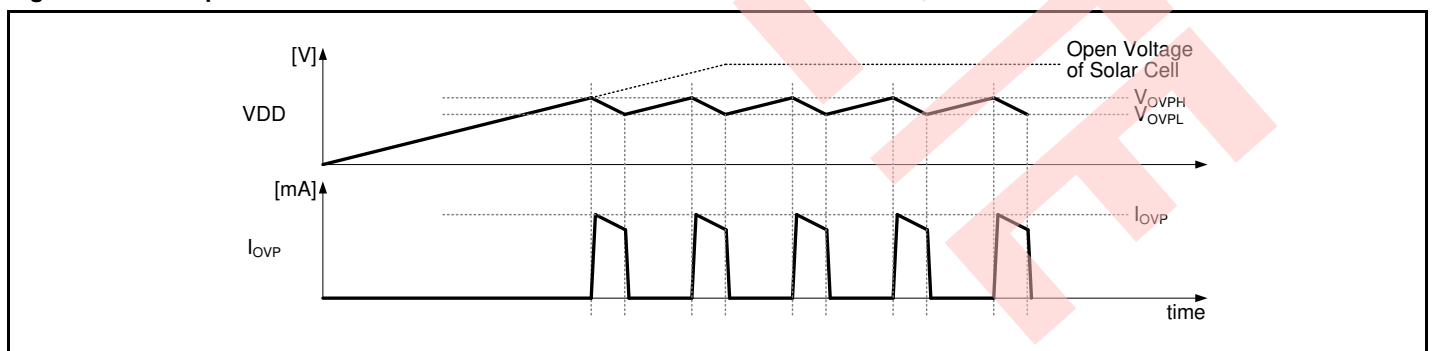



## 8. Application Circuit Example and Parts list

Figure 8-1 Application Circuit Example

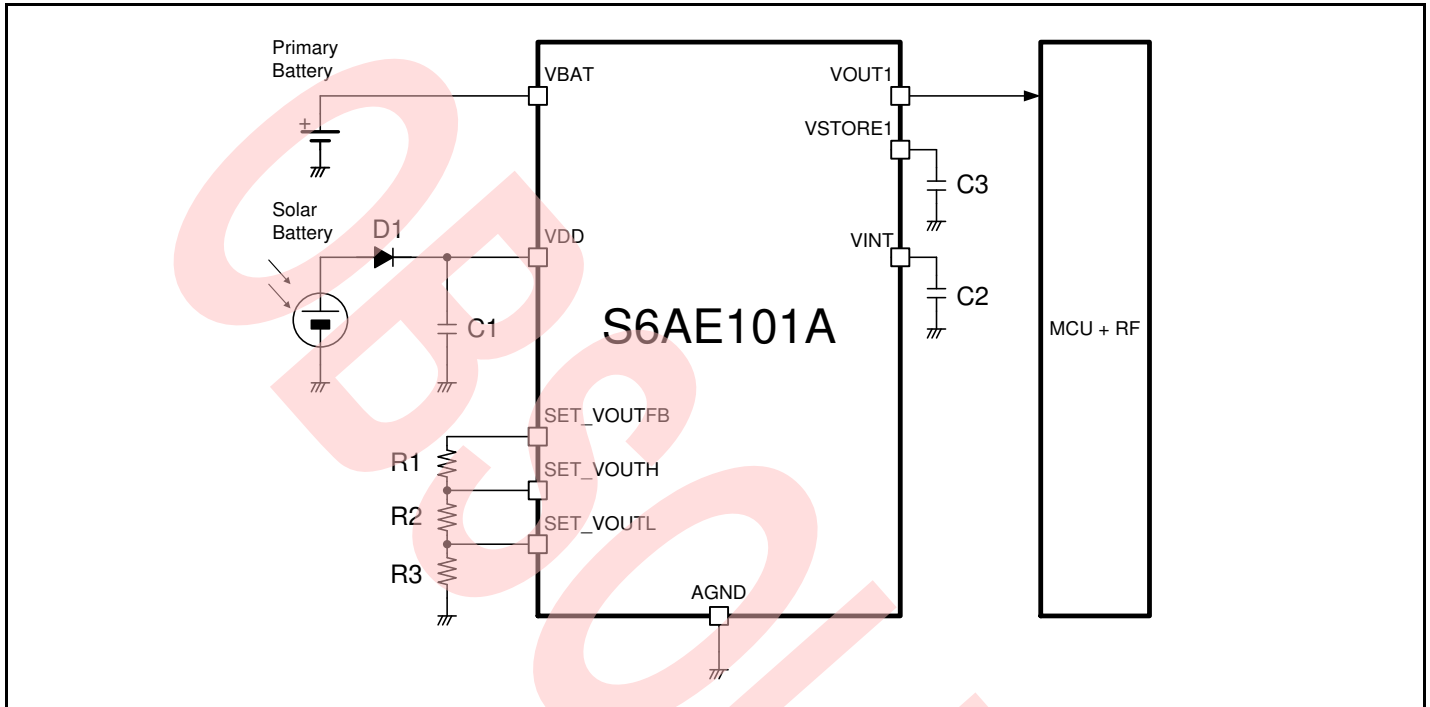

Table 8-1 Parts List

Symbol	Item	Value	Remarks
C1	Ceramic capacitor	10 $\mu$ F	-
C2	Ceramic capacitor	1 $\mu$ F	-
C3	Ceramic capacitor	100 $\mu$ F	-
R1	Resistor	6.8 M $\Omega$ (*1)	-
R2	Resistor	2.7 M $\Omega$ (*1)	-
R3	Resistor	9.1 M $\Omega$ (*1)	-
D1	Diode	-	-

\*1: Setting of VOUT maximum voltage:  $V_{VOUTH} \approx 3.3V$ , VOUT minimum voltage:  $V_{VOUTL} \approx 2.6V$ .

## 9. Application Note

### 9.1 Setting the Operation Conditions

#### Setting of output voltage (VOUT1)

The resistor connecting the SET\_VOUTH pin and SET\_VOUTL pin can be changed to set the VOUT1 output voltage of this IC. This is because the VOUT maximum voltage ( $V_{VOUTH}$ ) and VOUT minimum voltage ( $V_{VOUTL}$ ) are set based on the connected resistance. The SET\_VOUTFB pin outputs a reference voltage for setting the VOUT maximum voltage and VOUT minimum voltage. Resistor voltage division can be performed on this reference voltage outside the IC for creating a voltage applied to the SET\_VOUTH pin and SET\_VOUTL pin.

**Figure 9-1 Setting of output voltage (VOUT1)**

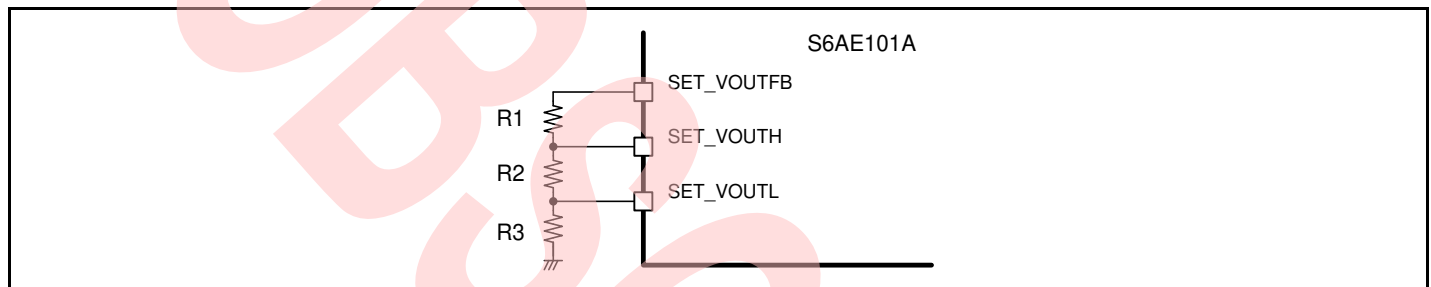

The VOUT maximum voltage ( $V_{VOUTH}$ ) and VOUT minimum voltage ( $V_{VOUTL}$ ) can be calculated using the formulas below.

VOUT maximum voltage

$$V_{VOUTH}[V] = \frac{57.5 \times (R2 + R3)}{11.1 \times (R1 + R2 + R3)}$$

VOUT minimum voltage

$$V_{VOUTL}[V] = \frac{57.5 \times R3}{11.1 \times (R1 + R2 + R3)}$$

The characteristics when the total value for R1, R2, and R3 is from 10 MΩ to 50 MΩ are shown in "6. Electrical Characteristics".

## 9.2 PCB Layout

### Take into account the following points when designing the layout.

- Try to route the wiring for the diode (D1) and input capacitor (C1) for connecting the solar cell on the top layer as much as possible, and avoid implementing a connection using a through hole.
- For the AGND pin of S6AE101A, provide a through hole nearby, and connect it to the GND plane.
- Locate the capacitor (C2) for the internal power as near as possible to the VINT pin.
- Locate the resistors (R1, R2, R3) for setting the output voltage in a grid-type configuration with small loops, and locate them as near as possible to each pin (SET\_VOUTFB, SET\_VOUTH, SET\_VOUTL). Also, removing the GND plane under the parts can be effective in preventing malfunctions due to the leakage current.
- To prevent a leakage current, locate and route the storage capacitor (C3) as far as possible from patterns that are different from the electrical potential of VSTORE1 (such as the GND line). Generally, the insulation resistor of printed circuit boards is extremely high, and normally, the passing of leakage current through the board does not pose a problem. However, in certain rare cases, the surface of the board may have a low insulation resistance, and when using these boards, a leakage current that cannot be ignored may occur.

Figure 9-2 PCB Layout Example

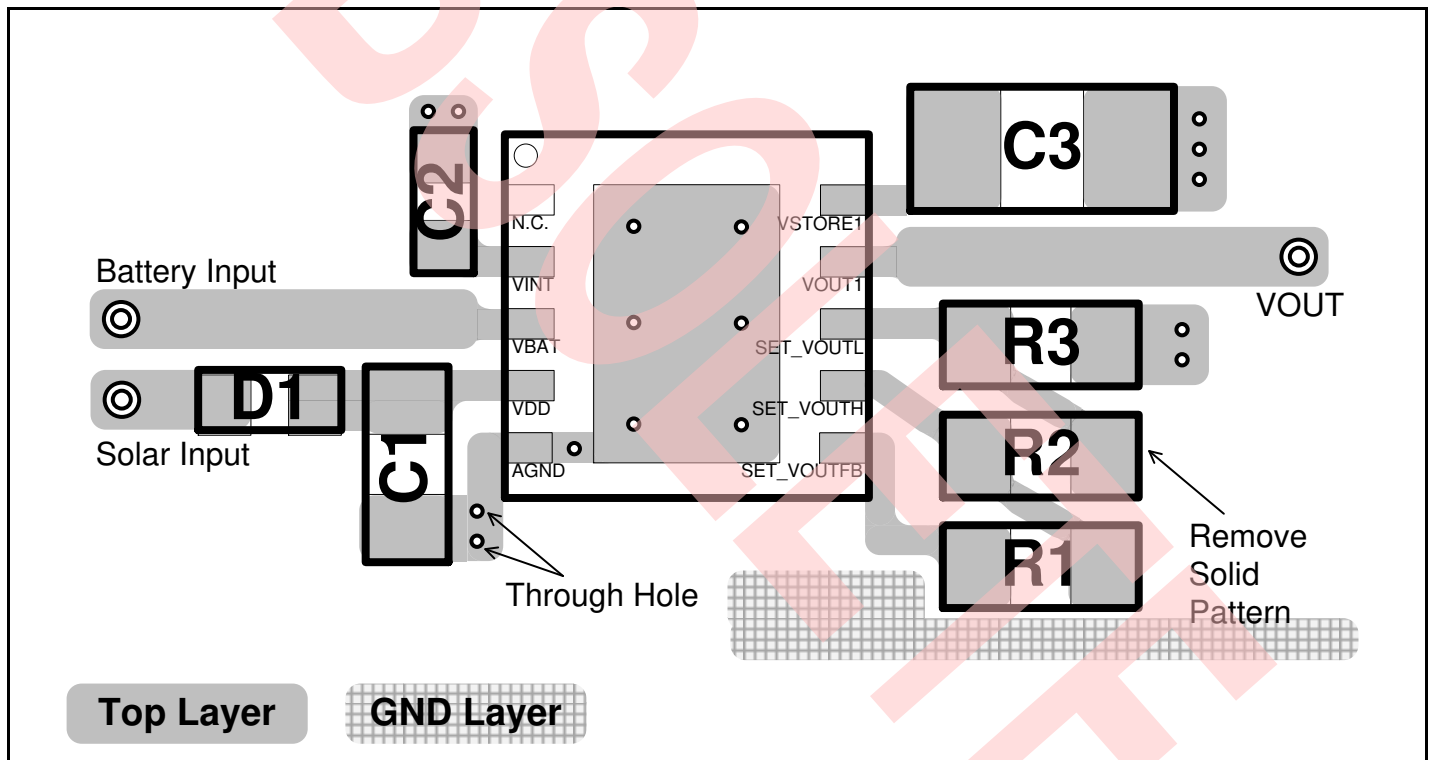

## 10. Development Support

This IC has a set of documentation, such as application notes, development tools, and online resources to assist you during your development process. Visit [www.cypress.com/energy-harvesting](http://www.cypress.com/energy-harvesting) to find out more.

## 11. Reference Data

For the circuit diagram of the reference data, Refer to "Figure 8-1 Application Circuit Example".

Figure 11-1 Reference Data

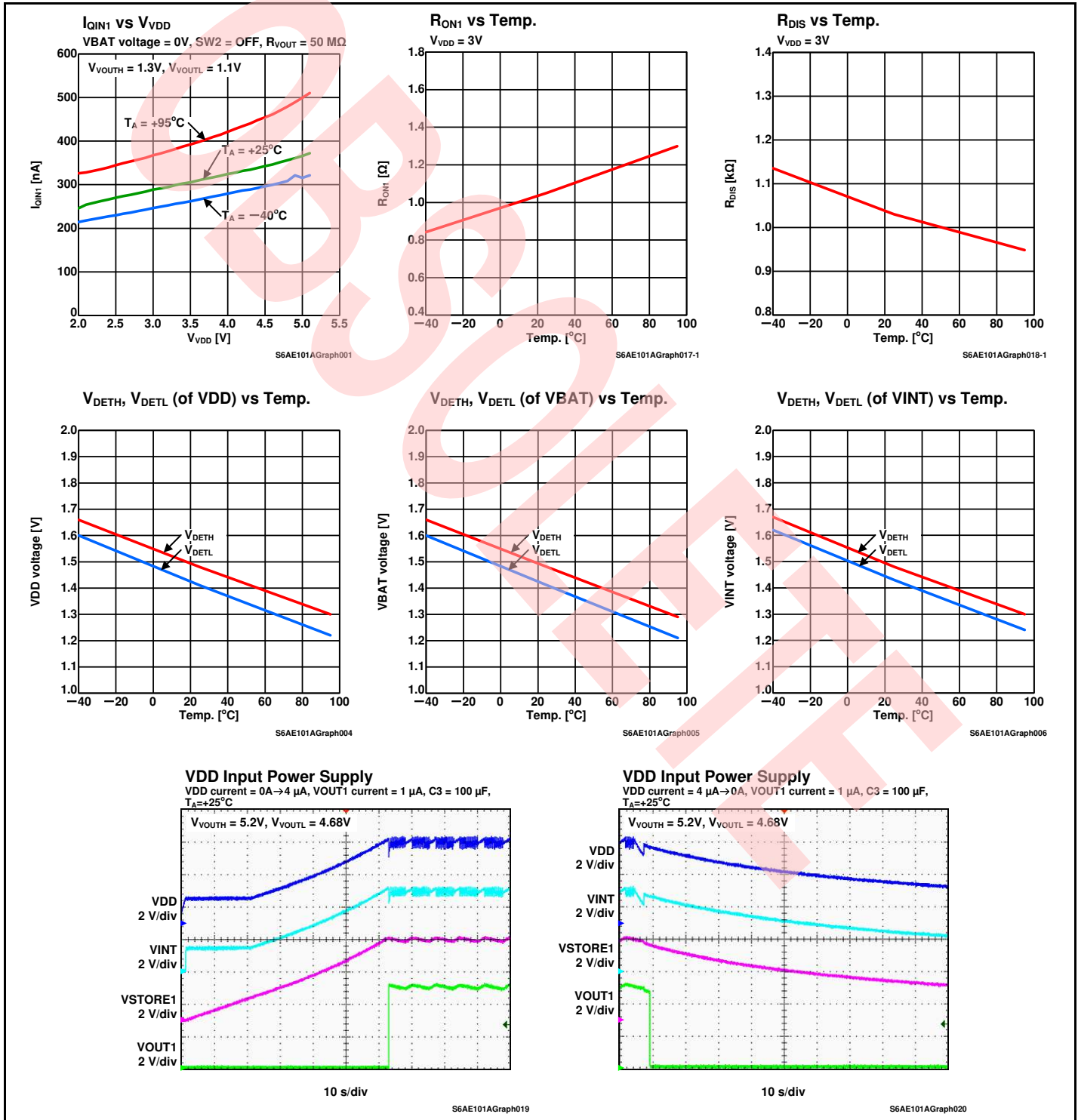

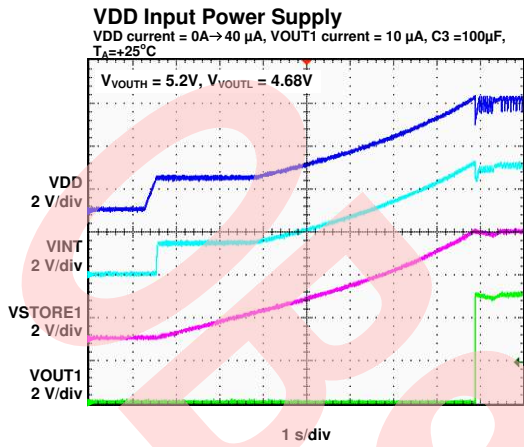

S6AE101AGraph021

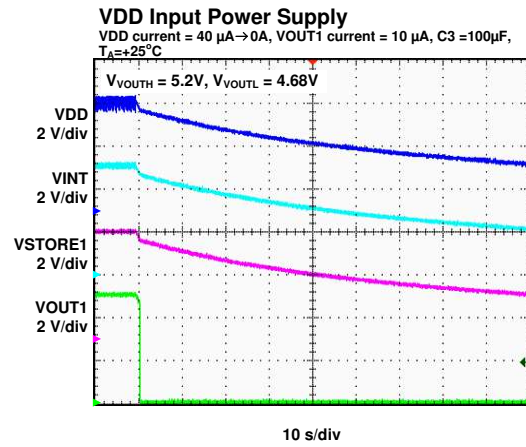

S6AE101AGraph022

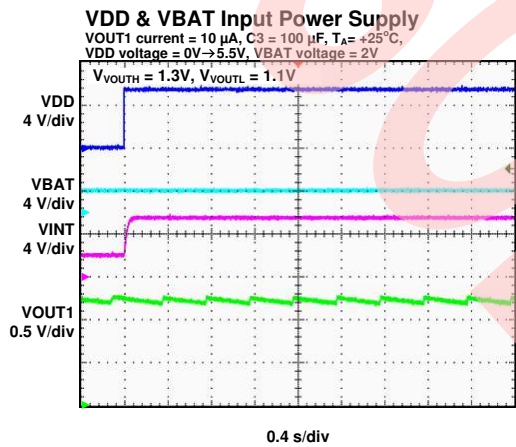

S6AE101AGraph027

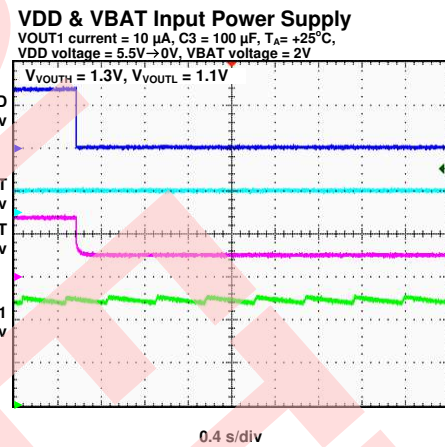

S6AE101AGraph028

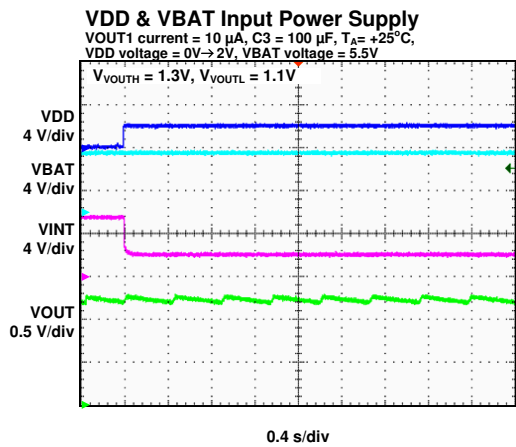

S6AE101AGraph029

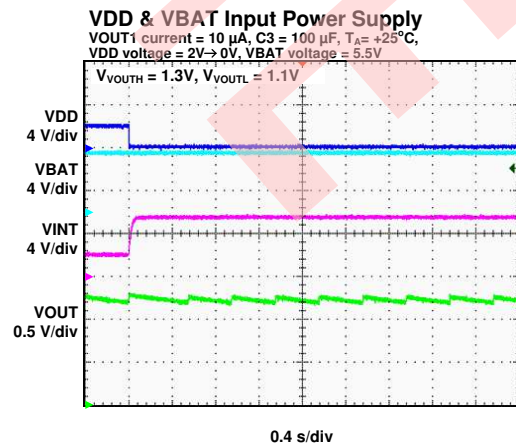

S6AE101AGraph030

## 12. Usage Precaution

Printed circuit board ground lines should be set up with consideration for common impedance.

### Take appropriate measures against static electricity.

- Containers for semiconductor materials should have anti-static protection or be made of conductive material.
- After mounting, printed circuit boards should be stored and shipped in conductive bags or containers.
- Work platforms, tools, and instruments should be properly grounded.
- Working personnel should be grounded with resistance of 250 kΩ to 1 MΩ in serial body and ground.

### Do not apply negative voltages.

The use of negative voltages below -0.3 V may make the parasitic transistor activated to the LSI, and can cause malfunctions.

## 13. RoHS Compliance Information

This product has observed the standard of lead, cadmium, mercury, Hexavalent chromium, polybrominated biphenyls (PBB), and polybrominated diphenyl ethers (PBDE).

## 14. Ordering Information

Table 14-1 Ordering Part Number

Part number (MPN)	Package
S6AE101A0DGNAB000	10-pin plastic SON (0.5mm pitch) (VNE010)

MPN: Marketing Part Number

Figure 14-1 Ordering Part Number Definitions

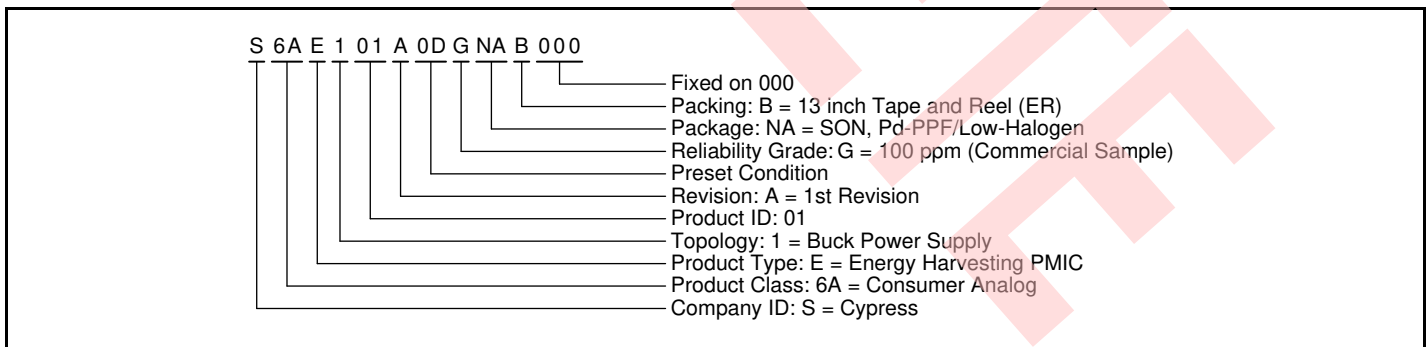

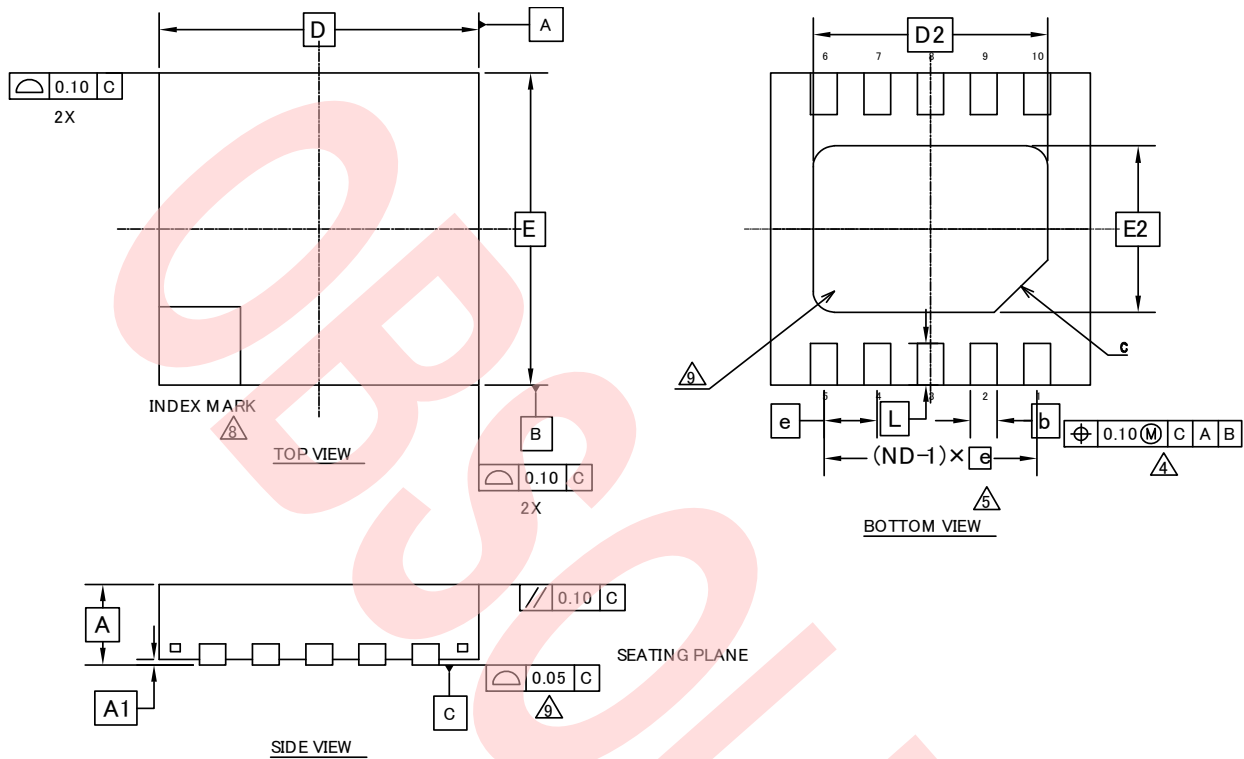
**15. Package Dimensions**

SYMBOL	DIMENSIONS		
	MIN.	NOM.	MAX.
A	—	—	0.90
A1	0.00	—	0.05
D	3.00 BSC		
E	3.00 BSC		
b	0.20	0.25	0.30
D2	2.20 BSC		
E2	1.60 BSC		
e	0.50 BSC		
c	0.50 REF		
L	0.30	0.40	0.50

**NOTES:**

- ALL DIMENSIONS ARE IN MILLIMETERS.
- DIMENSIONING AND TOLERANCING CONFORMS TO ASME Y14.5-1994.
- N IS THE TOTAL NUMBER OF TERMINALS.
- DIMENSION "b" APPLIES TO METALLIZED TERMINAL AND IS MEASURED BETWEEN 0.15 AND 0.30mm FROM TERMINAL TIP IF THE TERMINAL HAS THE OPTIONAL RADIUS ON THE OTHER END OF THE TERMINAL THE DIMENSION "b" SHOULD NOT BE MEASURED IN THAT RADIUS AREA.
- ND REFER TO THE NUMBER OF TERMINALS ON DORE SIDE.
- MAX. PACKAGE WARPAGE IS 0.05mm.
- MAXIMUM ALLOWABLE BURRS IS 0.076mm IN ALL DIRECTIONS.
- PIN #1 ID ON TOP WILL BE LOCATED WITHIN INDICATED ZONE.
- BILATERAL COPLANARITY ZONE APPLIES TO THE EXPOSED HEAT SINK SLUG AS WELL AS THE TERMINALS.

002-10864 \*\*

 PACKAGE OUTLINE, 10 LEAD DFN  
 3.0X3.0X0.9 MM VNE010 2.2X1.6MM EPAD (SAW N) REV\*\*

## 16. Major Changes

Spancion Publication Number: S6AE101A\_DS405-00026

Page	Section	Change Results
Preliminary 0.1		
-	-	Initial release

**NOTE:** Please see “[Document History](#)” about later revised information.

## Document History

Document Title: **S6AE101A Energy Harvesting PMIC for Wireless Sensor Node**

Document Number: **002-08493**

Revision	ECN	Orig. of Change	Submission Date	Description of Change
**	-	TAOA	04/27/2015	New Spec.
*A	5054369	TAOA	12/17/2015	Added <a href="#">Block Diagram</a> Updated <a href="#">5. Recommended Operating Conditions</a> Updated <a href="#">6. Electrical Characteristics</a> Updated <a href="#">Table 8-1 Parts List</a> Updated <a href="#">9.1 Setting the Operation Conditions</a> : Changed the formulas for the VOUT maximum voltage and VOUT minimum voltage.
*B	5103619	HIXT	01/25/2016	Added <a href="#">Figure 2-1 I/O Pin Equivalent Circuit Diagram</a> Updated <a href="#">Figure 3-1 Architecture Block Diagram</a> Added <a href="#">10. Development Support</a> Added <a href="#">11. Reference Data</a>
*C	5738855	GNKK	05/16/2017	Updated the Cypress logo.
*D	6364689	EIFU	10/25/2018	Remove Easy DesignSim comment
*E	7622363	ATTS	01/27/2022	Obsolete document. Completing Sunset Review.



## Sales, Solutions, and Legal Information

### Worldwide Sales and Design Support

Cypress maintains a worldwide network of offices, solution centers, manufacturer's representatives, and distributors. To find the office closest to you, visit us at [Cypress Locations](#).

#### Products

Arm® Cortex® Microcontrollers	<a href="http://cypress.com/arm">cypress.com/arm</a>
Automotive	<a href="http://cypress.com/automotive">cypress.com/automotive</a>
Clocks & Buffers	<a href="http://cypress.com/clocks">cypress.com/clocks</a>
Interface	<a href="http://cypress.com/interface">cypress.com/interface</a>
Internet of Things	<a href="http://cypress.com/iot">cypress.com/iot</a>
Memory	<a href="http://cypress.com/memory">cypress.com/memory</a>
Microcontrollers	<a href="http://cypress.com/mcu">cypress.com/mcu</a>
PSoC	<a href="http://cypress.com/psoc">cypress.com/psoc</a>
Power Management ICs	<a href="http://cypress.com/pmic">cypress.com/pmic</a>
Touch Sensing	<a href="http://cypress.com/touch">cypress.com/touch</a>
USB Controllers	<a href="http://cypress.com/usb">cypress.com/usb</a>
Wireless Connectivity	<a href="http://cypress.com/wireless">cypress.com/wireless</a>

#### PSoC® Solutions

[PSoC 1](#) | [PSoC 3](#) | [PSoC 4](#) | [PSoC 5LP](#) | [PSoC 6 MCU](#)

#### Cypress Developer Community

[Community](#) | [Projects](#) | [Videos](#) | [Blogs](#) | [Training](#)  
| [Components](#)

#### Technical Support

[cypress.com/support](http://cypress.com/support)

Arm and Cortex are registered trademarks of Arm Limited (or its subsidiaries) in the US and/or elsewhere.

© Cypress Semiconductor Corporation, 2015-2022. This document is the property of Cypress Semiconductor Corporation and its subsidiaries, including Spansion LLC ("Cypress"). This document, including any software or firmware included or referenced in this document ("Software"), is owned by Cypress under the intellectual property laws and treaties of the United States and other countries worldwide. Cypress reserves all rights under such laws and treaties and does not, except as specifically stated in this paragraph, grant any license under its patents, copyrights, trademarks, or other intellectual property rights. If the Software is not accompanied by a license agreement and you do not otherwise have a written agreement with Cypress governing the use of the Software, then Cypress hereby grants you a personal, non-exclusive, nontransferable license (without the right to sublicense) (1) under its copyright rights in the Software (a) for Software provided in source code form, to modify and reproduce the Software solely for use with Cypress hardware products, only internally within your organization, and (b) to distribute the Software in binary code form externally to end users (either directly or indirectly through resellers and distributors), solely for use on Cypress hardware product units, and (2) under those claims of Cypress's patents that are infringed by the Software (as provided by Cypress, unmodified) to make, use, distribute, and import the Software solely for use with Cypress hardware products. Any other use, reproduction, modification, translation, or compilation of the Software is prohibited.

TO THE EXTENT PERMITTED BY APPLICABLE LAW, CYPRESS MAKES NO WARRANTY OF ANY KIND, EXPRESS OR IMPLIED, WITH REGARD TO THIS DOCUMENT OR ANY SOFTWARE OR ACCOMPANYING HARDWARE, INCLUDING, BUT NOT LIMITED TO, THE IMPLIED WARRANTIES OF MERCHANTABILITY AND FITNESS FOR A PARTICULAR PURPOSE. No computing device can be absolutely secure. Therefore, despite security measures implemented in Cypress hardware or software products, Cypress does not assume any liability arising out of any security breach, such as unauthorized access to or use of a Cypress product. In addition, the products described in these materials may contain design defects or errors known as errata which may cause the product to deviate from published specifications. To the extent permitted by applicable law, Cypress reserves the right to make changes to this document without further notice. Cypress does not assume any liability arising out of the application or use of any product or circuit described in this document. Any information provided in this document, including any sample design information or programming code, is provided only for reference purposes. It is the responsibility of the user of this document to properly design, program, and test the functionality and safety of any application made of this information and any resulting product. Cypress products are not designed, intended, or authorized for use as critical components in systems designed or intended for the operation of weapons, weapons systems, nuclear installations, life-support devices or systems, other medical devices or systems (including resuscitation equipment and surgical implants), pollution control or hazardous substances management, or other uses where the failure of the device or system could cause personal injury, death, or property damage ("Unintended Uses"). A critical component is any component of a device or system whose failure to perform can be reasonably expected to cause the failure of the device or system, or to affect its safety or effectiveness. Cypress is not liable, in whole or in part, and you shall and hereby do release Cypress from any claim, damage, or other liability arising from or related to all Unintended Uses of Cypress products. You shall indemnify and hold Cypress harmless from and against all claims, costs, damages, and other liabilities, including claims for personal injury or death, arising from or related to any Unintended Uses of Cypress products.

Cypress, the Cypress logo, Spansion, the Spansion logo, and combinations thereof, WICED, PSoC, CapSense, EZ-USB, F-RAM, and Traveo are trademarks or registered trademarks of Cypress in the United States and other countries. For a more complete list of Cypress trademarks, visit [cypress.com](http://cypress.com). Other names and brands may be claimed as property of their respective owners.