

REVISIONS			
REV	DESCRIPTION, ECN, EAR NO.	DATE	APP'D
A	PROPOSAL	MAR 21,16	L.CHAN
B	UPDATED HOUSING POST	MAY 28,21	KELVIN.T

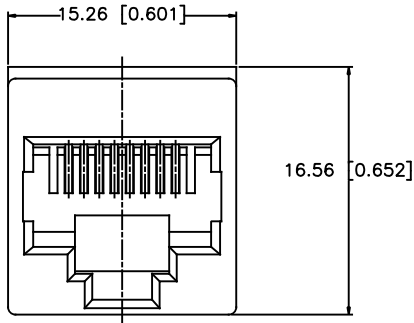

FRONT VIEW

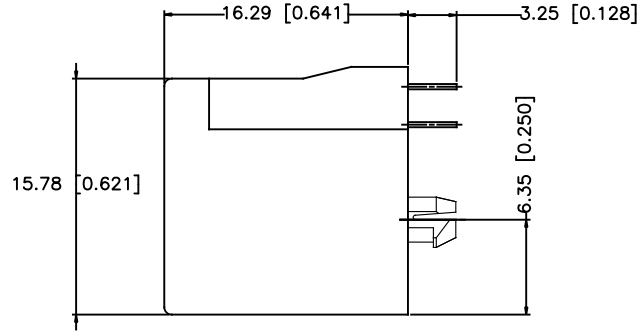

SIDE VIEW



1. MATERIALS

HOUSING: HIGH TEMPERATURE THERMOPLASTIC
FLAMMABILITY RATING UL 94V-0, COLOR: BLACK

CONTACTS: PHOSPHOR BRONZE

PLATING: SELECTIVE GOLD PLATING ON MATING SURFACES

SEE AMPHENOL PART NUMBER FOR DETAIL.

50u" [1.27 MICRONS] MIN. NICKEL UNDERPLATE

100u" [2.54 MICRONS] MIN. MATTE TIN ON CONTACT TAILS.

2. RECOMMEND SOLDER PROCESS

WAVE SOLDER ,PEAK TEMPERATURE 260° FOR 5~8 SECOND

REFLOW SOLDER ,PEAK TEMPERATURE 260° FOR 10 SECOND MAX

PART NUMBER: RJE08-188-0X10-H

GOLD PLATING:

- 1 = 6 μ"
- 2 = 15 μ"
- 3 = 30 μ"
- 4 = 50 μ"

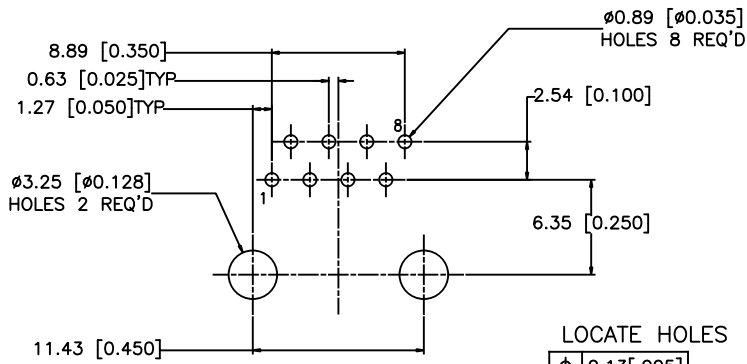

RECOMMENDED P.C.B. LAYOUT
(COMPONENT SIDE OF BOARD)
TOLERANCE: ±0.05 [.002](TOP VIEW)

LOCATE HOLES
⌀ 0.13 [.005]
POSITION DIMENSIONS
ARE BASIC

UNLESS SPECIFIED OTHERWISE	DRAWN	FRANK.W	DATE	03/21/2016
PRIMARY UNITS MILLIMETER	CHECKED	L.CHAN	DATE	03/21/2016
SECONDARY INCH	M.E. APP'D			
REFERENCE IN PARENTHESES	Q.A. APP'D			
GENERAL TOLERANCES	DWG APPR.			
1 DECIMAL PLACE ±0.30	ENG. REL. NO.			
2 DECIMAL PLACES ±0.25	REF.			
3 DECIMAL PLACES ±0.20	THIRD ANGLE PROJECTION			
ANGULAR DEGREES ±1.0°	DO NOT SCALE DRAWING			

Amphenol Canada Corp. www.amphenolcanada.com	
TITLE MODULAR JACK, TOP ENTRY, 8 POSITION, 8 CONTACTS, WITHOUT FLANGE, UNSHIELDED, - RoHS COMPLIANT	
DWG. NO. P-RJE08-188-0X10-H	REV B
CODE ID NO. 03554	DWG SIZE: C SCALE: N/A SHEET 1 OF 1