

# molex<sup>®</sup>

**TM-3000 Universal Press  
TM-4000 Universal Press  
Operation Manual for the following order numbers**

**63801-7200 (TM-3000, 120V)**



**63801-7300 (TM-3000, 240V)**













**63801-7600 (TM-4000, 240V)**









- Description
- Operation
- Maintenance

## Safety Warnings and Information

	<p><b>Read and understand</b> all of the instructions and safety information in this manual before operating or servicing this tool.</p> <p style="text-align: center;"><u>Keep this manual available when using this tool.</u></p> <p>Replacement manuals are available for download at no charge at <a href="http://www.molex.com">www.molex.com</a>.</p>
---	---

<b>SAFETY ALERT SYMBOL</b>	
<p>This symbol is used to call your attention to hazards or unsafe practices which could result in an injury or property damage. The signal word, defined below, indicates the severity of the hazard. The message after the signal word provides information for preventing or avoiding the hazard.</p>	
 <b>DANGER</b>	<p><b>DANGER:</b> Indicates an imminently hazardous situation which, if not avoided, could result in death or serious injury.</p>
 <b>WARNING</b>	<p><b>WARNING:</b> Indicates a potentially hazardous situation which, if not avoided, could result in death or serious injury.</p>
 <b>CAUTION</b>	<p><b>CAUTION:</b> Indicates a potentially hazardous situation which, if not avoided, may result in minor or moderate injury. <b>CAUTION</b> may also be used to alert against unsafe practices associated with events that could lead to personal injury.</p>

	<p> <b>WARNING</b></p> <p><b>Always</b> wear proper eye protection when operating or servicing this equipment.</p> <p>Failure to wear eye protection could result in serious eye injury from flying debris.</p>		<p> <b>WARNING</b></p> <p><b>Heavy Object</b> To avoid muscle strain or back injury, use lifting aids and proper lifting techniques when moving this press. Failure to observe these precautions may result in injury or property damage.</p>
	<p> <b>WARNING</b></p> <p><b>Never</b> wear clothing or jewelry that is loose or that could potentially snag in the press and get caught.</p> <p>Failure to observe this warning could result in severe injury or death.</p>		<p> <b>WARNING</b></p> <p><b>Never</b> install or service this machine while connected to any electrical power source. Disconnect power by unplugging the press from its power source.</p> <p>Failure to observe this warning could result in severe injury or death.</p>
	<p> <b>WARNING</b></p> <p><b>Never</b> operate, service, install, or adjust this machine without proper instruction and without first reading and understanding the instructions in this manual and all applicable press and/or wire processing machine manuals.</p>		<p> <b>WARNING</b></p> <p><b>Always</b> hand cycle the applicator in the press to ensure the tooling is properly aligned.</p> <p>Failure to observe these precautions may result in injury or property damage.</p>

	 <b>WARNING</b>	 <b>WARNING</b>
	<p><b>Never</b> use this press or wire processing machine without guards or safety devices that are intended to prevent hands from remaining in the die space.</p> <p>Failure to observe this warning could result in severe injury or death.</p>	 <p><b>Do not use</b> compressed air to clean this equipment. The forces created by compressed air can force debris into the tool.</p> <p>Failure to observe these precautions may result in injury or property damage.</p>
	 <b>WARNING</b>	
<p><b>Always</b> wear proper ear protection when operating or servicing this applicator.</p>		
 <b>CAUTION</b>		
<p>The Molex applicators are designed to operate in presses with standard shut heights of 135.80mm (5.346”). Installation in crimp presses with other than standard shut heights can cause severe tool / applicator damage. It is advisable that before installation, a check of the shut height be performed. Molex will not be liable for any damages as a result of installation in a crimp press with nonstandard or improperly set shut height.</p> <p>Failure to observe these precautions may result in injury or property damage.</p>		
 <b>CAUTION</b>		
<p><b>Never</b> perform any service or maintenance other than as described in this manual.</p> <p><b>Never</b> modify, alter or misuse the equipment</p> <p>Molex crimp specifications are valid only when used with Molex terminals, applicators and tooling.</p> <p>Failure to observe this precaution may result in injury and property damage.</p>		

**Tooling Technical Assistance**

Molex offers tooling technical assistance for customers who may need some guidance for tooling adjustments. This support can be obtained by calling either of the two numbers listed below and asking for the Molex Tooling Group. Call Toll Free 1-800-786-6539 (US) 1-630-969-4550 (Global).

This assistance is limited to the operation and set-up of a customer's Molex Press. Questions with regard to Molex connector products or how to identify the proper tooling and/ or tooling documentation should be directed to your local Molex personnel or Customer Service Representative.

When calling for service on the press a copy of the Tooling Manual and Specific Applicator Tooling Specification Sheet should be present and a person that is familiar with the applicator should be present. Be sure the following information is supplied:

1. Customer name
2. Customer address
3. Person to contact such as (name, title, e-mail, and telephone number)
4. Applicator order number (Lease number also if applicable)
5. Serial number (Lease number also if applicable)
6. Molex Connector product order number
7. Urgency of request
8. Nature of problem

**Molex Application Tooling Group**  
 2200 Wellington Court  
 Lisle, IL 60532, USA  
 Tel: +1 (630) 969-4550  
 Visit our Web site at <http://www.molex.com>

## Table of Contents

### Contents

<b>TM-3000 Universal Press</b> .....	1
<b>TM-4000 Universal Press</b> .....	1
Safety Warnings and Information .....	2
Table of Contents .....	4
Section 1 .....	5
General Description .....	5
1.1 Description .....	6
1.2 Features .....	6
1.3 Technical Specifications .....	6
1.4 Delivery Check .....	7
1.5 Tools .....	7
Section 2 .....	8
Installation .....	8
2.1 Lifting/Mounting .....	9
2.2 Foot Pedal and Power Connection .....	9
2.3 Reel Support .....	9
2.4 Pneumatic Supply Hook-Up (See Figure 3-2 and 3-3) .....	10
2.5 Terminal Feed Guide .....	11
2.6 Shut Height .....	11
2.7 Safety and Work Area Check .....	12
2.8 Guards .....	12
Section 3 .....	15
Setup and Operation .....	15
3.1 Applicator Installation .....	16
3.2 Air Feed Applicator Installation .....	16
3.3. Manually Cycling the Press .....	18
3.4. Operation .....	18
Section 4 .....	21
4.1 Maintenance .....	22
4.2. Oiler .....	22
4.3 Troubleshooting .....	23
Section 5 .....	24
5.1. Main Parts List .....	25
5.2. Main Assembly .....	27
5.2 Main Assembly (Continued) .....	28
5.3. Electrical Schematic .....	33
5.3. Pnuematic Schematic .....	34
Section 6 .....	35
6.1 EC Declaration of Conformity .....	35

## Section 1

### General Description

- 1.1 Description
- 1.2 Features
- 1.3 Technical Specifications
- 1.4 Delivery Check
- 1.5 Tools

## General Description

### 1.1 Description

The 63801-7200 (120V AC version), the 63801-7300 (240V AC version) TM-3000 Universal Press and the 63801-7600 (240V AC version) TM-4000 Universal Press are economical, electrically-operated, single-cycle and split cycle direct drive presses. They are designed to provide an effective method of applying a wide range of side-feed and rear-feed terminals to a pre-stripped discrete wire or cable. Both the TM-3000 and the TM-4000 are suited to mid-volume semi-automatic operations.

Production flexibility is obtained using interchangeable FineAdjust or Mini-Mac applicators and most Industry Standard Applicators.

These presses will complete one crimping cycle with each depression of the foot pedal and two depressions for split cycle. Safe operation is provided by an interlock switch that renders the press inoperative if the safety guard is opened or removed. These presses also have a secondary interlock switch in the back of the motor where the hand cycle wrench is used to prevent the foot switch from cycling during hand cycling operations or if the hand cycle wrench is accidentally left in the motor.

### 1.2 Features

- Utilizes both FineAdjust and Mini-Mac applicators side and rear feed, and most industry standard applicators
- Press is set to 135.80mm (5.346") Industry shut height
- Ideal for mid-volume, semi-automatic applications
- Meets O.S.H.A. safety standards is ANSI-Z535.2-2002 compliant
- Totally enclosed for operator safety, including a power interlock switch for the front guard
- Resettable counter for accurate batch counting
- Modular solid state controls with an easy plug in power cord and foot switch.
- "CE" Certified

### 1.3 Technical Specifications

#### Dimensions with reel mounted

Height	1210mm (47.60")
Width	648mm (25.50")
Depth	559mm (22.00")
Unpacked weight	113.4kg (250 lb)
Shipping weight	140.61kg (310 lb)

#### Press Stroke

TM-3000	30mm (1.125")
TM-4000	30mm (1.125")

#### ★Power Requirements

Voltage: 63801-7200 TM-3000 -120V AC 60 Hz (10 AMP)  
 Voltage: 63801-7300 TM-3000 -240V AC 50 – 60 Hz (10 AMP)  
 Voltage: 63801-7600 TM-4000 -240V AC 50 – 60 Hz (10 AMP)

#### Note:

If 240V power is not available, then 120V power may be used with an appropriate (1000VA minimum) step-up transformer. This transformer is available from Molex, order number 62500-2992. The power cord 62500-1774 is required for the 62500-2992 step-up transformer to work for each of the following presses order number 63801-7300 and 63801-7600. Both presses come with the power cord order number 62500-1774. It is not required to be ordered with the purchase of the 62500-2992 step up transformer unless a replacement cord is needed.

- ★ The TM-3000 and TM-40000 press systems require only electrical power, however these press systems include an air valve for air feed applicators where air is required (Mylar Tape Applicators for example).

**Pneumatic Requirements (Air Feed Applicators only)**

75 psi min. (0.5MPa) min.  
 1.0 SCFM (28.3 L/min)  
 ¼" NPT inlet 12.7mm (1/2") supply pipe minimum.

**Production Rate**

2400 terminations per hour maximum, depending on operator skill, terminal and wire length.

- ★ TM-4000 press has a slightly slower cycle rate due to the larger range and force capability.

**Processing Capability**

TM-3000 Press output = 4000 lbf (18kN).  
 Copper conductors up to 10 AWG (5.0mm<sup>2</sup>) in solid or stranded wire.

TM-4000 Press output = 7000 lbf (31kN).  
 Copper conductors up to 4 AWG (21.0mm<sup>2</sup>) in solid or stranded wire, insulated or un-insulated connector products.  
 Copper conductors up to 2 AWG (34.0mm<sup>2</sup>) in stranded wire un-insulated connector products only.

**Sound Level**

Operator will be exposed to less than 85 dBA.

## 1.4 Delivery Check

After removing the packaging band, the top and sides of the box should lift off easily. The following items are included in this package :

	<u>Quantity</u>
Press Assembly	1
63801-7290 Reel Support Assembly	1
63801-7264 Hand Cycle Wrench (8mm square socket wrench)	1
63801-7271 Foot Pedal	1
TM-638007299 Operation Manual	1

**Carton Contents**

	<u>Quantity</u>
69018-6237 Power Cord 110V (for 63801-7200)	1

**OR**

62500-1774 Power Cord 220V 10A (for 63801-7300 and 63801-7600)	1
---	---

## 1.5 Tools

The following tools are recommended for setup and adjustments to the applicator in this press

- ✓ Metric hex wrench set
- ✓ Small standard screwdriver
- ✓ Adjustable wrench
- ✓ Needle nose pliers
- ✓ Crimp micrometer (Molex part no. 63800-2820)
- ✓ Eye loupe (10x) (Molex part no. 63800-2810)
- ✓ Wire stripper/cutter
- ✓ English hex wrench set for some non-metric applicators

## Section 2

### Installation

- 2.1 Lifting/Mounting
- 2.2 Reel Support
- 2.3 Foot Pedal and Power Connection
- 2.4 Pneumatic Supply Hook-up
- 2.5 Terminal Feed Guide
- 2.6 Function Test
- 2.7 Safety and Work Area Check



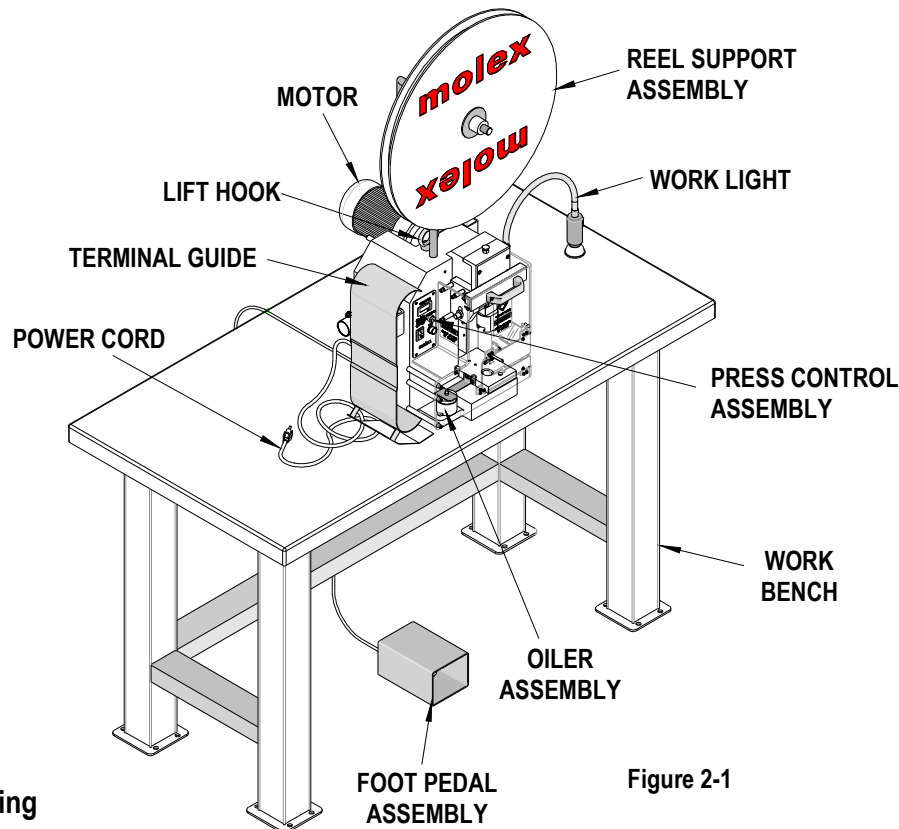

Figure 2-1

## 2.1 Lifting/Mounting



**WARNING:** This Press weighs over 100 kg (220 lb); it should not be lifted by one individual. Mechanical lifting devices should be used. A person lifting the press can sustain severe back or other injuries.

A lifting hook is provided on top of the press. A heavy-duty chain, rope, cable, or belt can be used with loops, links, or rings on each end that can securely attach to the lifting hooks. An electric, hydraulic, or mechanical crane should be used to lift the press. Lift the press up approximately 12mm (.50") and verify that the press is well balanced. Upon verification, the press can be lifted onto a sturdy workbench. Access to the back of the machine is required for manual hand cycling. A wooden bench that is a minimum of 25mm (1.00") thick will offer quiet vibration-free operation. For thinner or sheet metal tops, the TM-3000 can be attached to the table with two 12mm bolts. Bolts are not supplied by Molex, however bolting presses to the work bench is recommended for all bench placements.

## 2.2 Foot Pedal and Power Connection

Connect the 3-pin plug for the foot pedal in the rear of the press control assembly. Turn the locking ring clockwise until tight. Connect the power cord plug to the socket in the back of the control assembly. Use a grounded power source. See Figure 2-2.

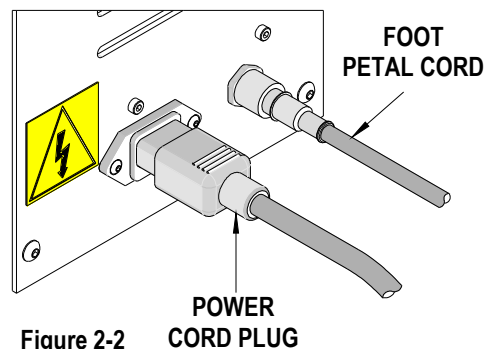

Figure 2-2

## 2.3 Reel Support

Install the reel support in the hole located on the top of machine frame. For rear feed, rotate the reel support as required. See Figure 2-4. Loosen the M10 set screw that holds the reel support. Pull up from the hole and rotate for the proper feeding orientation. Then slide down back into the hole and tighten the M10 set screw.

### To setup the reel support assembly:

- 1 Place one reel boss (order number 63801-7261) onto the reel support (order number 638017260).
- 2 Align the back of the reel support over the rear location of where the applicator is installed in the press.
- 3 Securely tighten the wing screw on the reel boss.
- 4 Next place reel spring (order number 638017263) onto the reel support.
- 5 Slide one reel discs (order number 638017262) onto the reel support.

- 6 Place the reel of terminals onto the reel support.
- 7 Install the second reel discs (order number 638017262) onto the reel support.
- 8 Slide the second reel boss onto the reel support with slight pressure against the back disc pushing on the spring and tighten the wing screw and securely tighten the wing screw. See Figure 2-3.

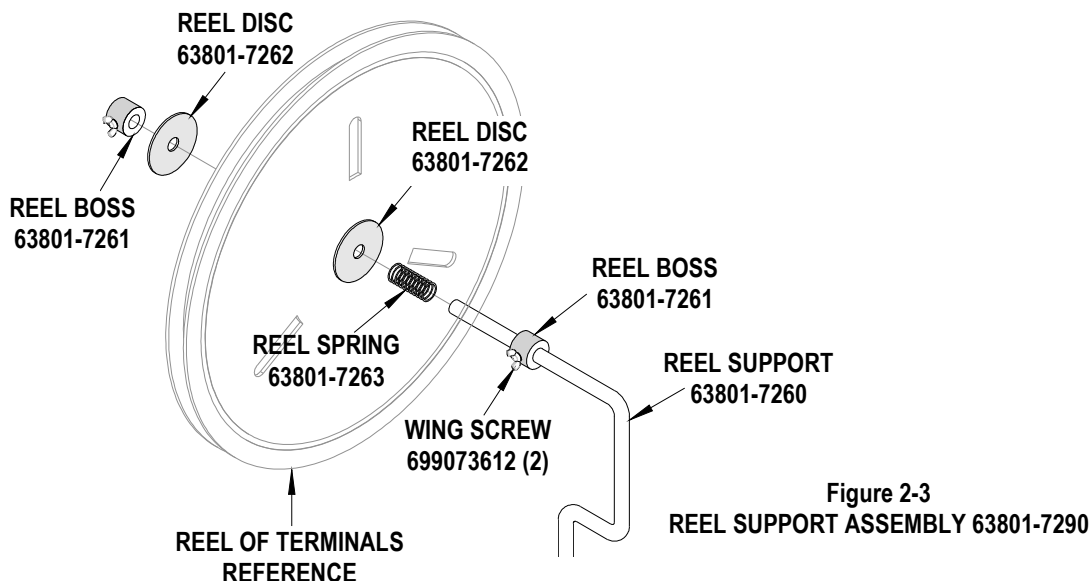

Figure 2-3  
REEL SUPPORT ASSEMBLY 63801-7290

**Note:** The reel bosses can be adjusted as needed depending on the application.

## 2.4 Pneumatic Supply Hook-Up (See Figure 3-2 and 3-3)

A compressed air supply is required if air feed applicators will be used. The press is equipped with an air compressed filter, regulator, lubricator and a valve to actuate the air feed at the proper time in the press cycle.

Due to the many types of air connection and quick connect air fittings available; Molex only supplies the press with a 1/4 NPT female threaded fitting. The customer may attach whatever type of air connections that are commonly used in their plant to this port.

The minimum supply line inside diameter should be 8mm or 5/16" to assure adequate flow.

A filter-regulator-lubricator unit is furnished to properly condition the supply air. The filter will remove particulate and moisture from the air that can damage or reduce the life of cylinders and valves. This filter and bowl should be serviced on a regular schedule. (See section 4.1) The filter has an automatic drain at the bottom of the bowl that will automatically open and expel fluid when the bowl is getting full. It is recommended that a 6mm or 1/4" flexible tube be attached to the drain hose barb and run to a container if the air supply contains excessive moisture.

The regulator adjusts the supply air pressure to the applicator. Typically an applicator requires 60-80 PSI (refer to the applicator manual for recommended pressures.) Adjustment is accomplished by pulling up on the knob, rotating it until the gauge indicates the desired pressure, then pushing it down to lock the setting.

A lubricator is supplied for those applicator air feeds that need lubrication. Molex air-feed applicators do not require lubrication. The lubricator is shipped without lubricant in it. To use, fill the lubricator (make sure the main air supply is disconnected or that the slide valve provided is in the off position before adding lubricant) through the fill plug on the top of the unit, with SAE 10W oil. The lubricator has a graduated dial on top, turn the dial to the 1 or 2 setting.



**Caution:** Do not over lubricate. Only a very small amount of lubricant is required to assure smooth operation. Excess lubricant is exhausted to the atmosphere.

If lubrication is not required set the dial to 0 to turn off the lubricator or remove.

## 2.5 Terminal Feed Guide

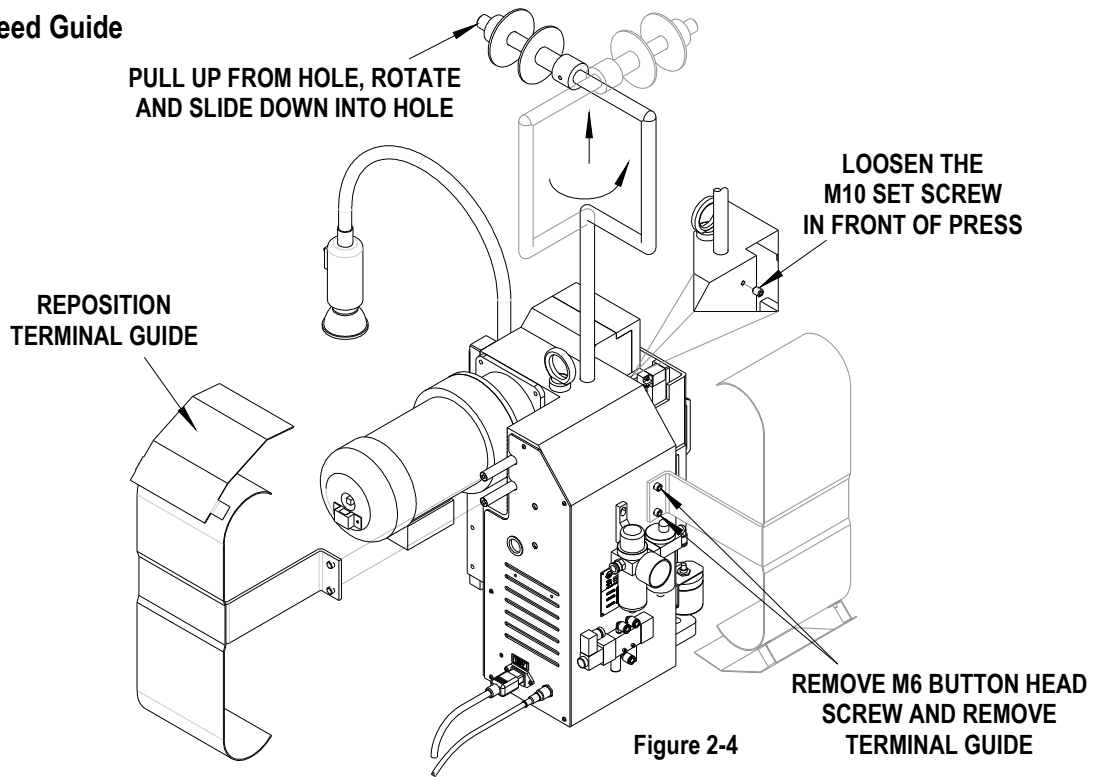

Depending on side or rear-feed applications, the terminal guide plate and bracket must be repositioned. The press is set for side-feed applicators when shipped from the factory. When rear-feed applicators are used, the two M6 button head screw from the terminal guide-mounting bracket are to be removed. See Figure 2-4. The guide bracket is rotated 180 degrees and the assembly is then mounted on the two standoffs in the rear of the press with the two M6 socket head screw. See Figure 2-4.

## 2.6 Shut Height

When the press is shipped from the factory, it is set to the industry shut height of 135.80 mm (5.346") with a calibrated gauge. Molex offers an industry standard shut height gauge (order number 63800-7900). The 63800-7900 will work with most industry standard crimp presses. It is recommended that the crimp press shut height be checked regularly. See Figure 2-5. See Section 3-3.

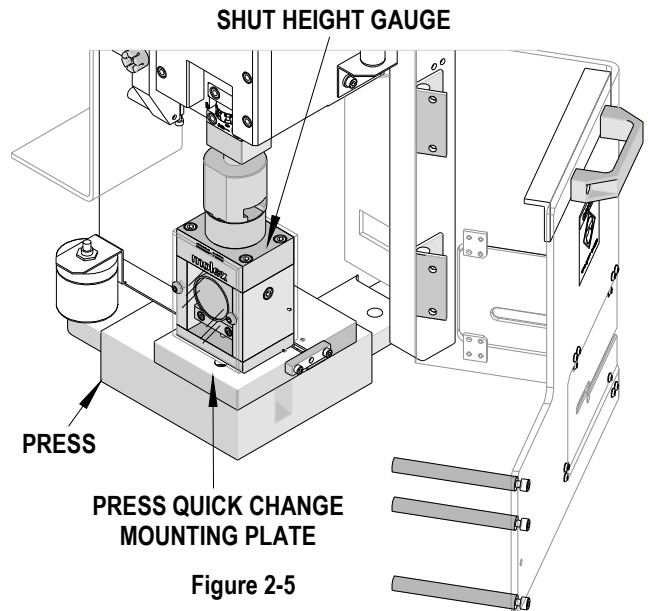

**CAUTION:** Always manually cycle the press after adjusting the shut height before restoring power to the machine.

### Verification of Press Shut Height

This press comes factory set at an Industry Standard shut height of 135.80mm (5.346"). A label is attached to the front of each press indicating the factory settings. This press has an adjustable shut height, see Section 3.4 for crimp height adjustment. Always return the press to the factory setting on the label before installing applicators to avoid tooling damage. Check the factory setting periodically with a calibrated shut height gage.

<p><b>FACTORY SETTING IS</b></p> <p><b>DXX</b></p> <p><b>DXX IS THE SHUT HEIGHT OF 135.80MM (5.346 INCH)</b></p>
--

## 2.7 Safety and Work Area Check

Check the crimping position is ergonomic for the operator's size. A bench height of 762. to 813.mm (30.0 to 32.0") will provide operator comfort, and allows both feet to rest on the floor. The foot pedal should be placed in a comfortable position. Check the press position is located approximately 150mm (6") from the edge of the bench. A chair or stool with adjustable height and backrest should be provided for maximum comfort and back support for the operator.



**CAUTION:** Molex recommends wearing eye protection when the press is in operation or being serviced.

The fuse is located on the control panel. To replace the fuse (10AMP on 110 V models and 5AMP on 220V models), turn the holder in the direction as shown. Turn clockwise to secure holder in place when replaced. See Figure 2-6.

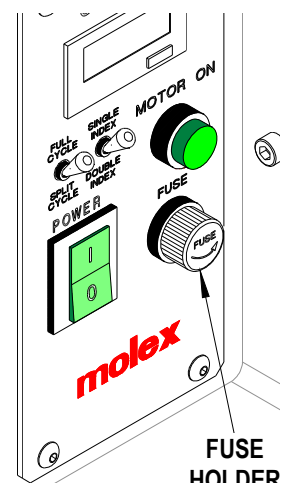

Figure 2-6

## 2.8 Guards

### Upgrade Kit Safety Guard for Old Styles of the TM-3000 and TM-4000 Guards

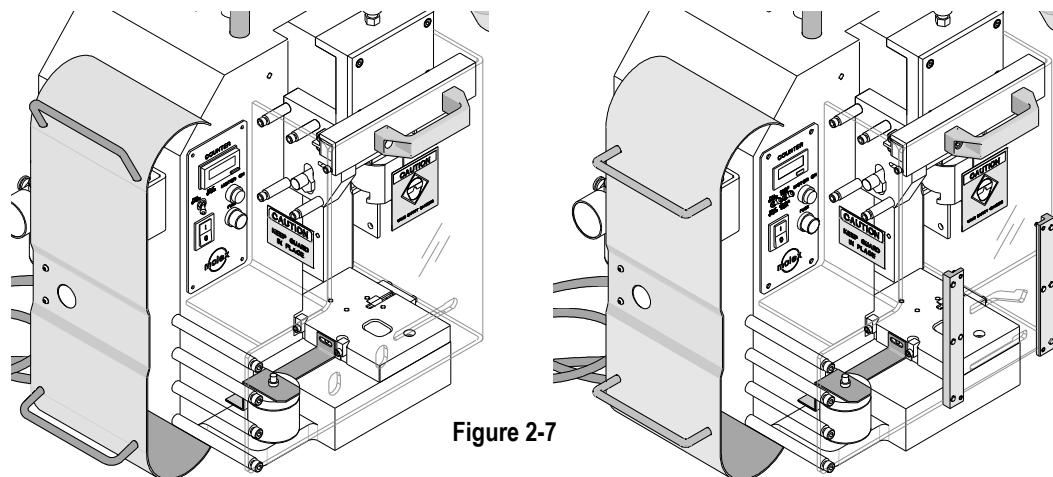

Figure 2-7

For existing presses, the 64016-2595 safety guard upgrade kit can be purchased separately. See documents: ATS-640162595. Applicable presses order numbers are Molex 63801-7200, 63801-7300, 63801-7600.

### New Safety Guard

Starting in 2012 all new presses will have the 64016-2590 Safety Guard Assembly factory installed. If the Safety Guard needs to be installed follow the steps below.

#### Installation:



**Always** turn off and disconnect the power supply to the press.

Before installing the guards the TM-3000/TM-4000 Press will need to be turned off. Use "POWER" switch located on the control panel to turn it off. See Section 3-4 Operation for location on the control panel.

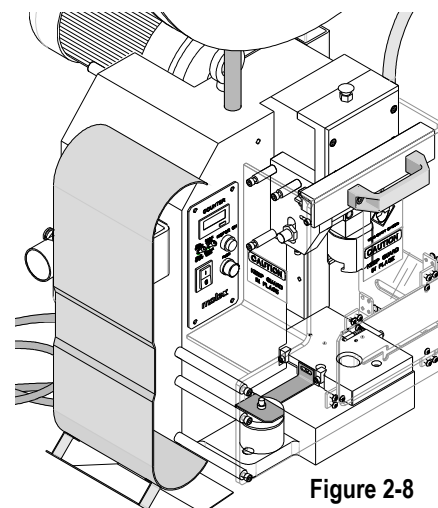

Figure 2-8

### Tools

To install the 64016-2595 Guard Assembly the following tools will be needed.

#3 Phillips Screw Driver

10mm Box Open End Wrench

3mm Allen Wrench

4mm Allen Wrench



1. Install the angle guard behind the existing lamp bracket. See Figure 2-9.



**NOTE:** The angle guard (64016-2581) must be installed to ensure operator safety.

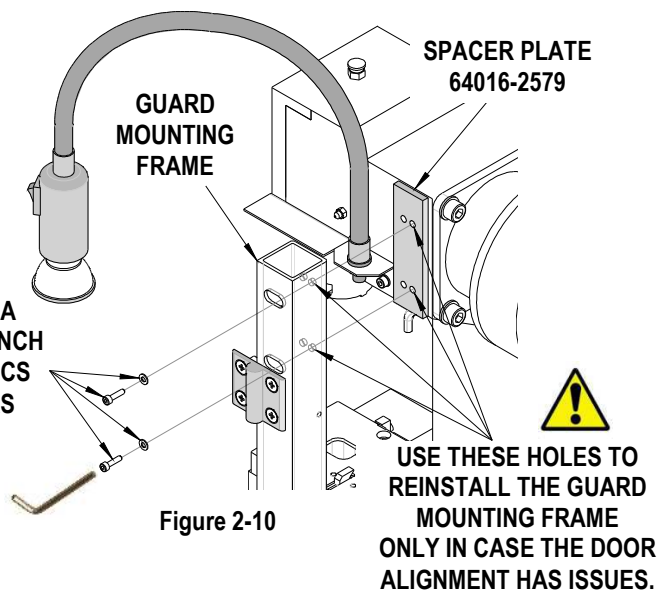
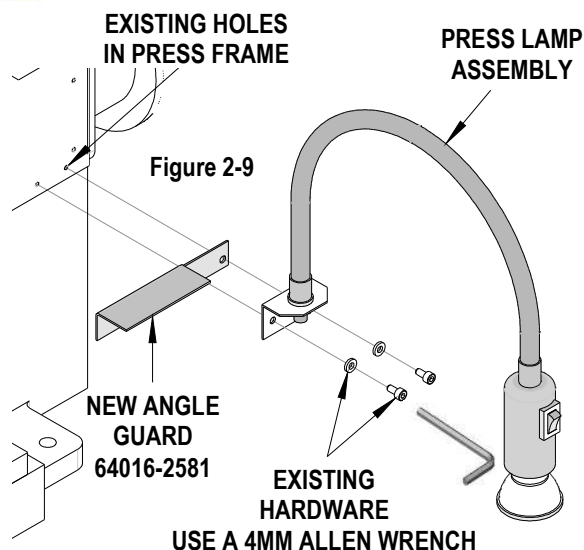

2. Install the spacer plate (64016-2579) and guard mounting frame on the press. The spacer plate should be aligned so its rear-most set of holes aligns to the threaded holes in the press frame.
3. Place the guard mounting frame over the spacer plate. Align the front set of holes in the guard mounting frame with the threaded holes in the press frame. Use M4 screws and washers to fasten the guard mounting frame and spacer plate to the press frame.



**NOTE:** if there are alignment problems with the guard door after installation, the rear set of holes in the guard mounting frame can be aligned with the threaded holes in the press frame. This will move the guard door forward.

4. Install the guard mounting frame. Use the left (Front) mounting holes that the guard mounting frame originally used.
5. Install the rear guard and the new front door assembly to the hinges. See Figure 2-11.

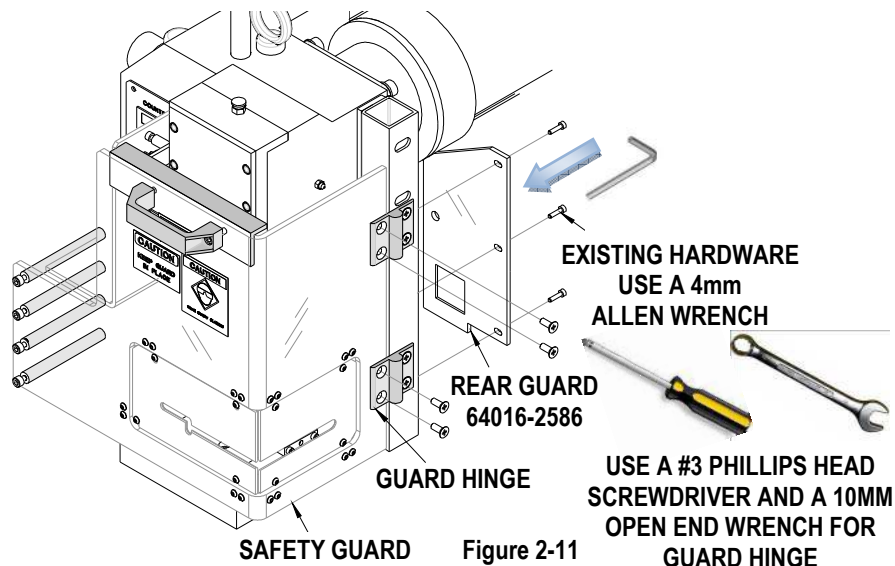

6. Install the lower terminal guide (64016-2522) to the terminal guide (63801-7234) with (2) M4 x 8mm BHCS. See Figure 2-12.

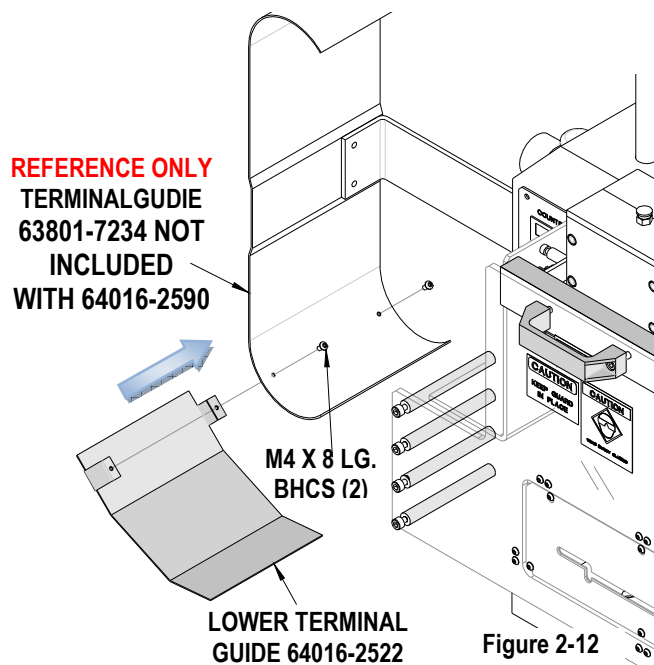

**NOTE:** Clearance holes may need to be drilled into the existing terminal guide on some older TM3000 presses.

## Section 3

### Setup and Operation

- 3.1 Applicator Installation
- 3.2 Air Feed Applicator Installation
- 3.3 Manually Cycling the Press
- 3.4 Operation

### 3.1 Applicator Installation



**Always** turn off and disconnect the power supply to the press. Turn off the “POWER” switch located on the control panel.

**Note:** Once the press guard is open the guard interlock switch will disconnect power to the motor.

**Steps**

1. Swing the press guard open.
2. Verify that the applicator is correctly tooled for the terminal being used. (Reference specification sheets supplied with the applicator).
3. Clean the press quick change mounting plate of scrap or chips that may interfere with the applicator installation. Use a soft brush not compressed air.
4. Using a 4mm hex wrench, turn the M5 socket head screw clockwise until the locking clamp is fully opened.
5. Slide the applicator lug bolt in the press yoke. See Figure 3-1.
6. Pull down on the applicator base plate slots with the locator clamps on the press quick change plate.
7. To lock applicator, turn M5 socket head screw counter clockwise until tight.
8. Confirm that the applicator is secured properly.
9. Remove the Molex ram spacer (order number 63443-7200) prior to hand cycling the press.

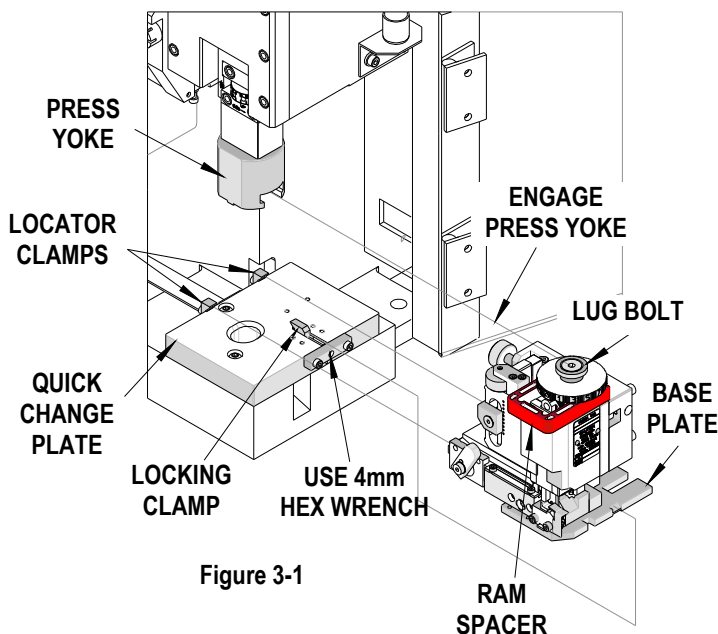

Figure 3-1

**Note:** A ram spacer should be used when storing or transporting your applicator. Remove ram spacer prior to hand cycling the press and replace it before removing the applicator from the press to avoid potential damage to the tooling.

### 3.2 Air Feed Applicator Installation



**Always** turn off and disconnect the power supply to the press. Turn off the “POWER” switch located on the control panel.

**Note:** Once the press guard is open the guard interlock switch will disconnect power to the motor.



**Warning:** When using air feed applicators, always use the slide valve to shut-off and vent air pressure before servicing. The guard interlock switch **DOES NOT** remove air pressure. If an air feed is jammed and air pressure is not removed before servicing, the feed could move unexpectedly and cause injury.

**Steps**

1. Swing the press guard open.
2. Verify that the applicator is correctly tooled for the terminal being used. (Reference specification sheets supplied with the applicator).
3. Clean the press quick change mounting plate of scrap or chips that may interfere with the applicator installation. Use a soft brush not compressed air.
4. Using a 4mm hex wrench, turn the M5 socket head screw clockwise until the locking clamp is fully opened.
5. Slide the applicator lug bolt in the press yoke. See Figure 3-1.
6. Pull down on the the applicator base plate slots with the locator clamps on the press quick change mounting plate.



7. To lock applicator, turn M5 socket head screw counter clockwise until tight.
8. Confirm that the applicator is secured properly.
9. Remove ram spacer order number 63443-7200 before hand cycling the press.

**Note:** A ram spacer should be used when storing or transporting your applicator. Remove ram spacer prior to hand cycling the press and replace it before removing the applicator from the press to avoid potential damage to the tooling.

10. Disconnect the air supply to with the press by sliding the shutoff valve sleeve to the left as shown in Figure 3-2. Remove the plugs from the fittings on the air valve. Do not discard the plugs; when the air applicator is not being used, the fittings should be plugged.

 **Note:** When not using an air feed applicator always shutoff the air supply to the filter-regulator-lubricator by sliding the shutoff valve sleeve to the left, the opposite direction of the airflow, as shown in Figure 3-2.

 **Note:** Some applicators feed terminals in the retracted position, for those air tubes must be reversed. In addition, some applicators are air advance and spring return, on these applicators one valve port will need to be plugged.

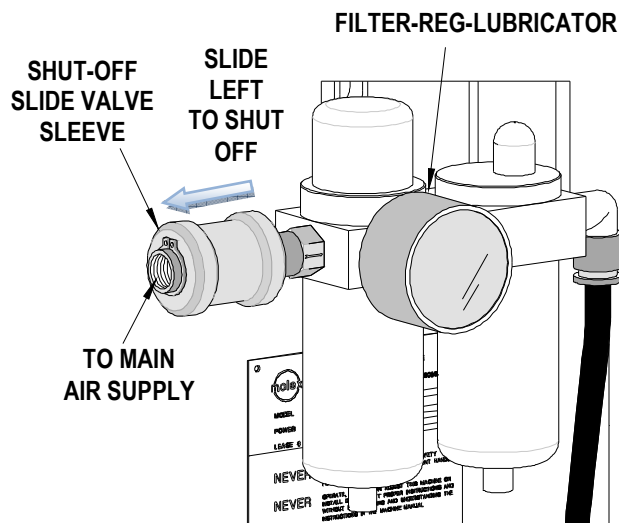

Figure 3-2

11. Insert the "A" port of the air valve with the tube that retracts the feed mechanism of the applicator. See Figure 3-3.
12. Insert the "B" port of the air valve with the tube that advances the feed mechanism of the applicator. See Figure 3-3.

**Note:** When using the 64016-2000 Crimp Module, set the feed selector on the control panel to "SINGLE" or "DOUBLE", depending on the spacing of the taped terminals. See Figure 3-5.

13. Connect the main air supply to the filter reg-lubricator. (Customer supplied fitting)
14. Adjust the regulator to 75-80 PSI (520-550kPa).
15. Check that the tubing for the applicator is properly connected by dry cycling the press and observing the feed motion.

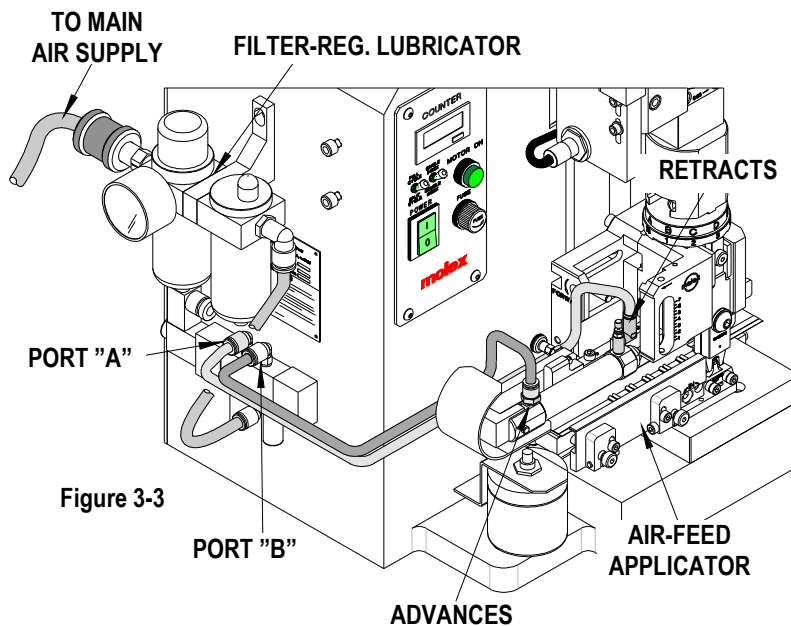

Figure 3-3

### 3.3. Manually Cycling the Press



**Always** turn off and disconnect the power supply to the press.



**Always** hand cycle the applicator in the press to ensure the tooling is properly aligned.

**Note:** Once the wrench is inserted into the back of the motor, the guard interlock switch will disconnect power to the motor.

Hand cycling the press is necessary to confirm correct tool alignment and terminal feed adjustment. It also gives the setup person the ability to step through the press cycle manually. However with no terminal or wire in the applicator there should be no resistance. If there is any resistance, stop. Put the ram back to the starting cycling position and evaluate where the resistance is coming from. It could be a tool alignment issue or wrong shut height problem.

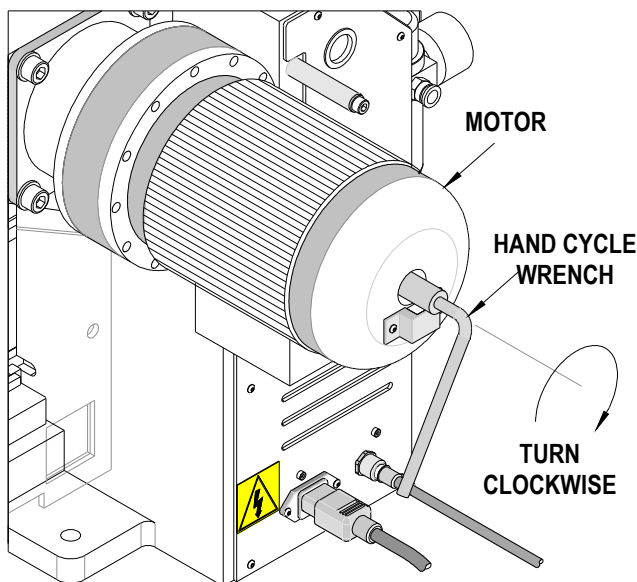

Figure 3-4

#### Steps

1. Insert the hand cycle wrench (order number 63801-7264) through the access hole in the center of the motor rear cover. Rotate the wrench to engage the motor shaft. See Figure 3-4.
2. Rotate the wrench clockwise. This turns the motor and moves the ram down and up.
3. Always return the ram back to top insuring the ram is in the start position.
4. Remove the hand cycle wrench (order number 63801-7264).

**NOTE:** When the hand cycle wrench is put into the motor shaft the motor turns off automatically.

### 3.4. Operation

#### Full Cycle Operation



**CAUTION:** Make sure the press guard is in position and all setup procedures are followed. Follow the safety and work area instructions.

#### Steps:

1. Set the toggle switch on the control panel to "Full Cycle". See Figure 3-5.
2. Turn the "Power" switch on, the power indicator light will illuminate.
3. Press the "Motor On" push button, the motor indicator light will illuminate. After a 5 second delay the press will be ready to cycle.
4. Place the prestripped wire through the slot in the press guard and push until it contacts the applicator's wire stop. See Figure 3-6.
5. Press the foot pedal down once. Use a sweeping motion to the right to remove the crimped terminal.
6. Check the crimped terminal and confirm that it meets the specifications and visual inspection.
7. Make sure the applicator properly fed the next terminal into position.
8. Repeat steps 4 and 5 for the next crimp.

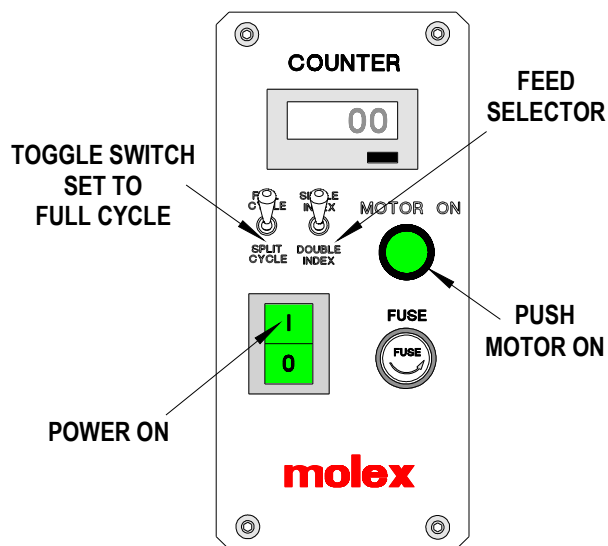

Figure 3-5

### Split Cycle Operation

**Description:**

The split cycle is used only for closed barrel terminals, and helps to locate the terminal before crimping the wire. The ram will close partially to assist in locating the terminal for the termination. With the terminal located the wire can be placed into the terminal and terminated. To setup the machine for split cycle push the toggle switch on the control panel to “Split Cycle”. See Figure 3-5.

**Steps:**

1. Depress the foot switch once, the ram will lower partially, positioning the terminal for termination.
2. Place the prestripped wire into the terminal.
3. Depress the foot switch a second time. The ram will complete its downward stroke and return to the top position to complete the cycle of terminating the crimp.

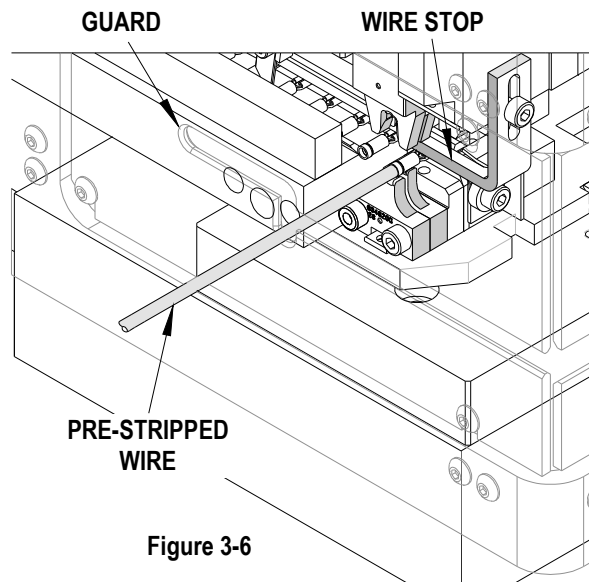

Figure 3-6



**CAUTION:** Make sure the press guard is in position and all setup procedures are followed. Follow the safety and work area instructions.

### Split Cycle Ram Adjustment

When setting up an applicator for split cycle operation it may be necessary to adjust the split position of the ram (1st position), so the terminal will be captured by the punch but not terminated. For adjustment, the sensor located on the left side of the ram cover needs to be adjusted. See the following steps:

**Steps:**

1. Depress the foot switch once, with the terminals in the applicator. See where the punch is located in the split position.
2. If the punch is too high and does not hold the terminal, or the punch is too low partially crimping the terminal, the sensor needs to be adjusted.
3. Open the press guard.
4. Loosen the two M12 jam nuts on the split cycle sensor, located on both sides of the sensor bracket. Then loosen the M4 jam nut holding the M4 X 25 socket head screw. Turn the M4 screw clockwise to raise or counter-clockwise to lower. See Figure 3-7. Raise the sensor if the punch is partially crimping the terminal; or lower the sensor if the ram is not closing far enough and not centering the terminal.
5. Tighten the M4 socket head screw and the (2)M12 jam nuts positioning the sensor for the split cycle position. See Figure 3-7.
6. Close the press guard.
7. Repeat step 1 to check for the correct position of the ram. (Be sure Ram is at top dead center first.)

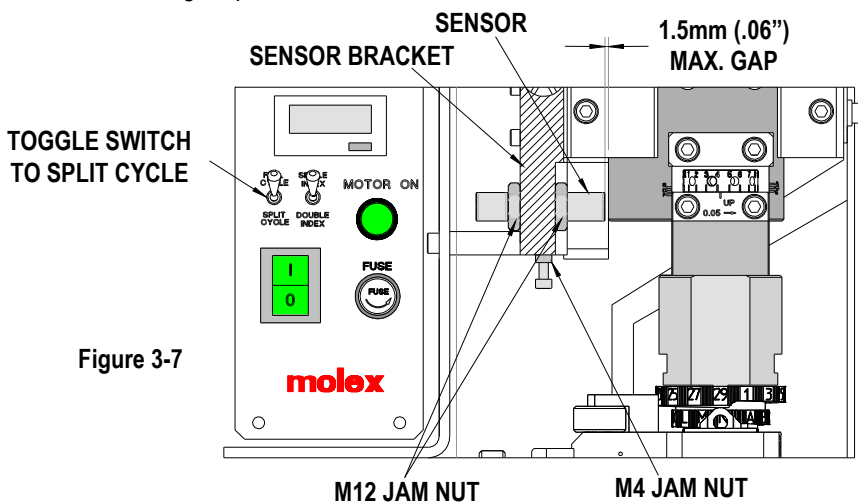

Figure 3-7

**Note:** The gap between the sensor and the ram should be 1.5mm (.06") Max. See Figure 3-7.

**CAUTION:** Always return the ram to the top dead center position or start position of the cycle before recycling the press. This is done by manually cycling the press. See section 3.3.

**Crimp Adjustment**

See Section 2.6.1 for Industry standard shut height.

**Crimp Adjustment Full and Split Cycle**

If conductor crimp height adjustment is required and cannot be made by the cam adjustment on the applicator, the press ram can be adjusted by following the steps below.

**Steps:**

1. Open the press guard.
2. Loosen the four M6 socket head screws on the front of the press.
3. Rotate the adjustment dial to the right to raise crimp height or to the left to decrease. Dial indicator lines represent increments of .05mm (.002"). See Figure 3-8.
4. When adjustment is complete, retighten the four M6 socket head screws.
5. Close the guard.
6. Place a prestripped wire into the terminal and terminate under power. Examine the quality of the crimp.
7. Repeat steps 1 thru 6 if the desired crimp is not achieved.

**CAUTION:** Use **Caution** adjusting the ram downward. Over adjustment in this direction may cause tooling damage or breakage.

**CAUTION:** Always return the adjustment to the factory setting before installing another applicator, or recalibrating shut height. See Section 2.6.1.

**Note:** Molex does not recommend making shut height adjustments to any bench top crimp press. All adjustments should be made at the applicator including shimming of the applicator if required to achieve the proper crimp height for the crimped terminal. Bench top presses should remain at the industry standard of 135.80mm (5.346").

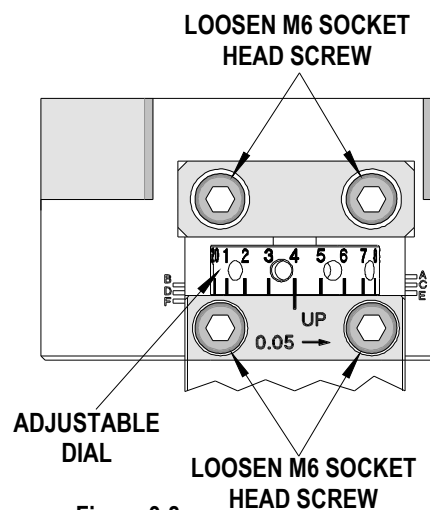

Figure 3-8

## Section 4

- 4.1 Maintenance
- 4.2 Oiler
- 4.3 Troubleshooting

### 4.1 Maintenance



**Always** turn off and disconnect the power supply to the press. Turn off the "POWER" switch located on the control panel.

For efficient operation the press should be cleaned daily with a soft bristle brush to remove any carrier strip debris and terminal plating dust from the tooling area.

#### Maintenance Schedule

The following is offered as a general guideline for maintenance. Tool life can be increased with good maintenance practices or decrease with lack of maintenance.

Item	Frequency Cycles	Frequency Time	Materials
Air Filter	100,000	Weekly	Clean bowl and sintered filter with denatured alcohol
Air Lubricator	100,000	Weekly	SAE 10W oil. Check and refill if used
Ram	N/A	Never	SAE 10W oil Oil Cup (Top of ram) See Figure 4-8.
Main Bearing	50,000	Once a year	Grease fitting right side of Press bearing lube
Cleaning	25,000	Daily	Use soft bristle brush on Applicator mounting plate

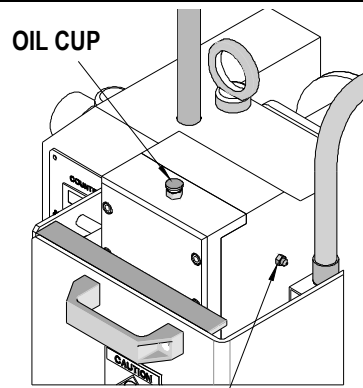

Figure 4-8 GREASE FITTING

### 4.2. Oiler

#### Description

The wick action oiler is included with the press. The oiler applies a thin coat of lubricant to the terminals, which helps with feeding and better release from termination punches. The oiler is primarily used for terminals with gold plating. To avoid contamination when shipped and during setup, the oiler is shipped from the factory with no lubricant oil. The oiler should only be used on applicators that require lubrication. Customer must supply lubricant.

#### Oiler Position

Adjust the position of the oiler unit using the mounting screw that attaches the oiler to the quick change mounting plate. Loosen the screw, slide the unit to the desired position, and tighten the screw. The unit can be removed and placed on the rear side of the quick change mounting plate for rear-feed applications.

#### Oiler Wick

Adjust the height of the oiler wick by pulling up or pushing down on the wick to the appropriate height. The wick can be moved using pliers or simply grab it with your fingers.

#### Filling the Reservoir

While firmly holding the lid, screw the jar (oil reservoir) counter clockwise until it is removed. Fill the jar with the correct lubricant oil and replace the lid.

#### Replacing the Wick

While firmly holding the lid, screw the jar oil reservoir counter clockwise until it is removed. Feed a new wick up into the tube until it protrudes from the top end of the tube and replace the lid. Replace the wick on a regular basis to ensure a proper application consistency

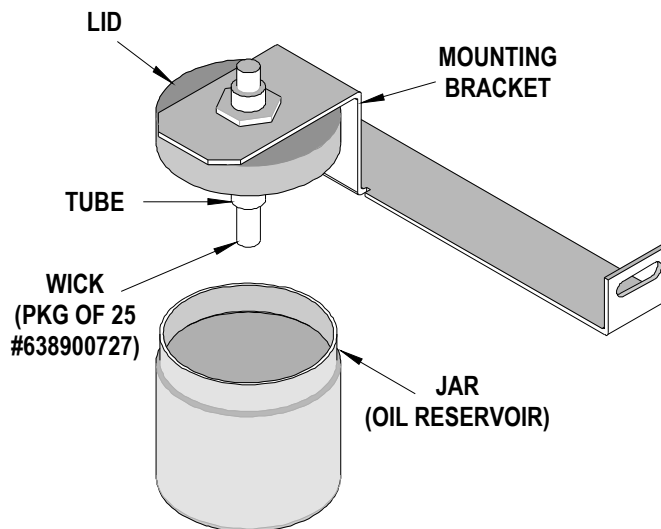

Figure 4-9 OILER ASSEMBLY

#### Package of 25 Wicks:

Molex Order No: 63890-0727

### Lubricant Oil for Terminal Oiler

Recommended oil: Transdraw B-19

- ◆ Vendor: Mid-Town Petroleum  
 9707 South 76<sup>th</sup> Avenue  
 Bridgeview, IL 60455  
 Toll-Free: 877-255-3533  
 Direct: 708-599-8700  
 Fax: 708-599-1040  
 E-mail: sales@midtownoil.com  
 www.midtownoil.com  
 www.precisionlubricantsinc.com

Transdraw B-19 is a vanishing lubricant that lubricates just enough and then evaporates so the terminals do not have any residue. B-19 is recommended for light to moderate duty operations for all metals and will not leave a film behind or leave very little depending on the operation and environment. It is recommended that you ensure the B-19 is suitable for your application and environment. A lubricant is highly recommended for all applications where gold plated terminals are being used or where terminals stick in the crimp punches. Using lubricant might help extend the life of your crimp punches and anvils.

◆ The lubricant vendor above has no affiliation to Molex nor is Molex promoting requiring any customer to use this supplier. This supplier is just one source and customers need to determine if this source is acceptable for their needs.

### 4.3 Troubleshooting

Symptom	Cause	Solution
Motor will not run	Power/Power cord failure	Check supply
	Loose connection	Refer to control schematic
	Guard interlock switch disengaged	Re-Install guard
	Fuse blown	Replace
	On/Off switch failure	Replace
	Motor failure	Replace
	T-wrench not removed from motor	Removed T-wrench from motor
	Control PCB not working	Replace
	Solid state relay not working	Replace
	Control board for motor	Repair or replace
Press will not cycle	Guard interlock switch disengaged	Re-Install guard
	Faulty footswitch	Check Connection. Repair or replace
	Control PCB not working	Replace
	Fuse blown	Replace
Press partially cycles	Toggle switch set to split cycle	Reset the toggle switch to full cycle

## Section 5

- 5.1 Parts List
- 5.2 Assembly Drawings
- 5.3 Electrical and Pneumatic Schematics



5.1. Main Parts List

TM-3000 Main Assembly (Figure 5-1 and 5-2)			
Item No.	Order No.	Description	Quantity
REF	63801-7200	Universal Press (110VAC)	See Notes Below
REF	63801-7300	Universal Press (220VAC)	See Notes Below
REF	63801-7600	Universal Press	See Notes Below
1	62500-1774	** Power Cord (220VAC) 10 AMP	1
2	63700-3845	Rotor Magnet	1
3	63801-7201	Press Frame	1
4	63801-7202	Ram	1
5	63801-7203	Follower	1
6	63801-7204	Front Cap	1
7	63801-7205	Press Face Plate	1
8	63801-7206	Switch-TDC	1
9	63801-7207	Flag Pickup	1
10	63801-7209	Oil Fill Cap	1
11	63801-7210	Flag-Position	1
12	63801-7211	Split Cycle Prox	1
13	63801-7213	Yoke Adapter	1
14	63801-7214	Mounting Block Cover	1
15	63801-7215	Mounting Block	1
16	63801-7216	Press Yoke	1
17	63801-7217	Press Shaft	1
18	63801-7218	Shaft E-Ring	1
19	63801-7219	Front Bearing	1
20	63801-7222	Quick Change Plate	1
21	63801-7224	Name Plate (Universal Press)	1
22	63801-7232	Eye Bolt	1
23	63801-7233	Stand off	2
24	63801-7234	Terminal Guide	1
25	63801-7236	Terminal Guide Bracket	1
26	63801-7237	Press Lamp	1
27	63801-7238	Lamp Mounting Bracket	1
28	63801-7239	Guard Switch Prox	1
29	63801-7240	Oiler Assembly (Figure 5-3)	1
30	63801-7241	♦ Bulb-LED	N/A (See Note 7)
31	63801-7243	Alignment Block	2
32	63801-7244	Locking Clamp	1
33	63801-7245	Clamp Retainer	1
34	63801-7246	E-Ring	2
35	63801-7247	Rear Bearing	2
36	63801-7248	Motor with Gear Reducer	1
	63801-7648	*** Motor with Gear Reducer	1
37	63801-7249	Small E-Ring	1
38	63801-7250	* Motor Controller 110VAC	1
39	63801-7251	** Motor Controller 220 VAC	1

TM-3000 Main Assembly (Figure 5-1 and 5-2)			
40	63801-7252	Relay - Motor On	1
41	63801-7253	Transformer (18V)	1
42	63801-7254	PCB-Machine	1
43	63801-7256	Sensor Flag -Motor	1
44	63801-7257	Motor Shutoff Prox	1
45	63801-7258	Prox Motor Shutoff Bracket	1
46	63801-7259	Rear Cover	1
47	63801-7269	Filter-Regulator-Lubricator	1
48	63801-7270	Air Valve-3 Way	1
49	63801-7271	Foot switch with cord	1
50	63801-7272	Slide Valve	1
51	63801-7273	Label (Lightning Bolt) 1-1/2" Triangle	1
52	63801-7275	Label (Caution)	1
53	63801-7276	Plug (1/4" Tube)	2
54	63801-7277	Elbow Male (1/4" Tube) for Filter-Reg.-Lubricator	1
55	63801-7278	Elbow Male (1/4" Tube) for 3-Way Valve	3
56	63801-7283	Side Guard	1
57	63801-7284	Hinge Mounting Bracket	1
58	63801-7285	Guard Hinge	2
59	63801-7286	Guard Sensor Bracket	1
60	63801-7288	Stand-off, Guard Side	3
61	63801-7290	Reel Support Assembly	1
62	63801-7631	Control Panel	1
63	64016-2590	Safety Guard Assembly	1
64	69018-6237	* Power Cord (110VAC) 20 AMP	1
<p><b>Note:</b></p> <ol style="list-style-type: none"> <li>1. For TM-3000 Press 220VAC use assembly no. 63801-7300.</li> <li>2. For TM-4000 Press (220VAC only) use assembly no. 63801-7600.</li> <li>3. All parts for both 63801-7200 and 63801-7300 Presses unless otherwise specified.</li> <li>4. * Indicates parts for 63801-7200 (110VAC) Press only.</li> <li>5. ** Indicates parts for 63801-7300 (220VAC) Press only.</li> <li>6. *** Indicates parts for 63801-7600 Press only.</li> <li>7. ♦ 63801-7241 comes supplied with the Press Lamp (63801-7237)</li> </ol>			

### 5.2. Main Assembly

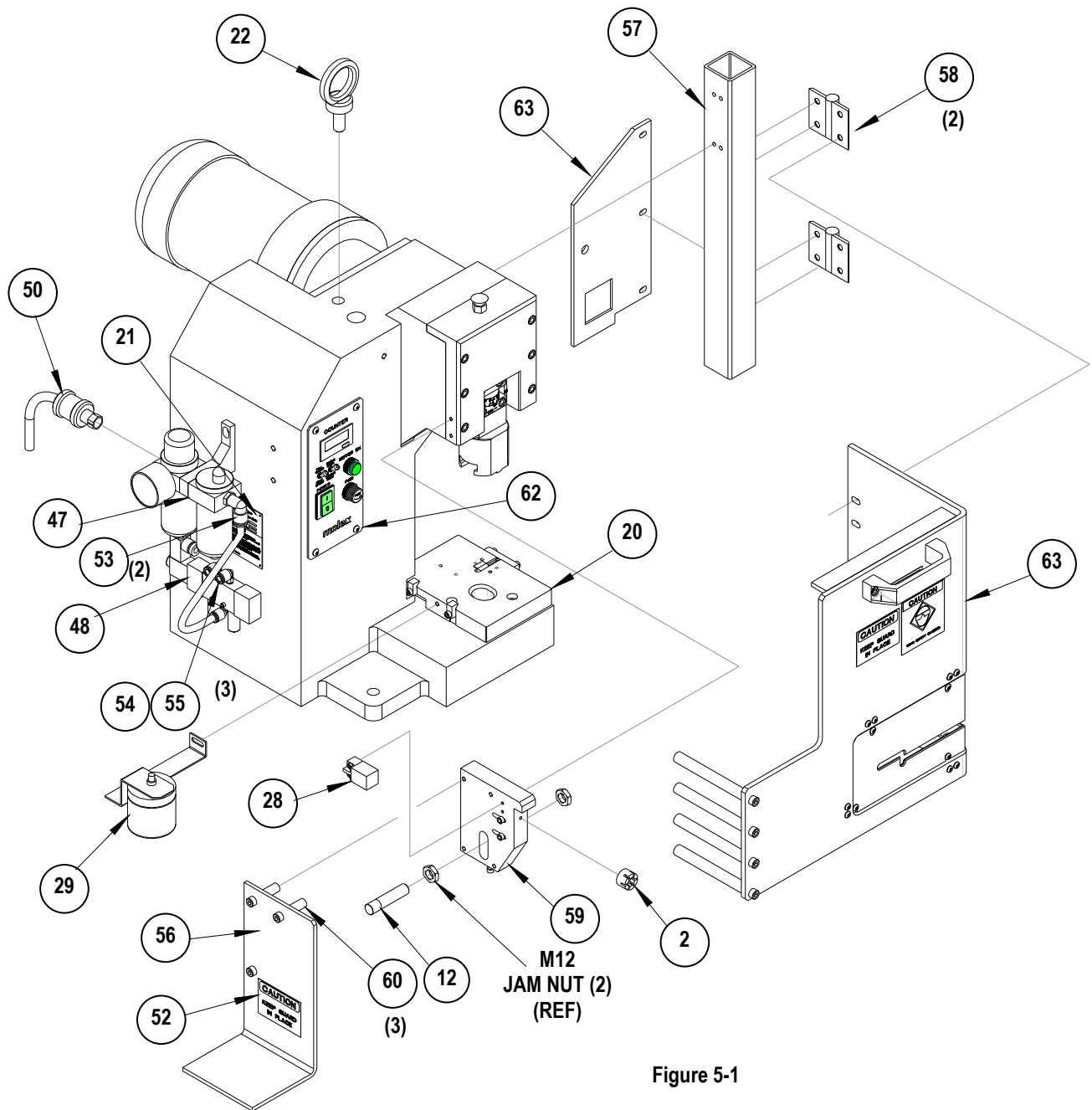

Figure 5-1

5.2 Main Assembly (Continued)

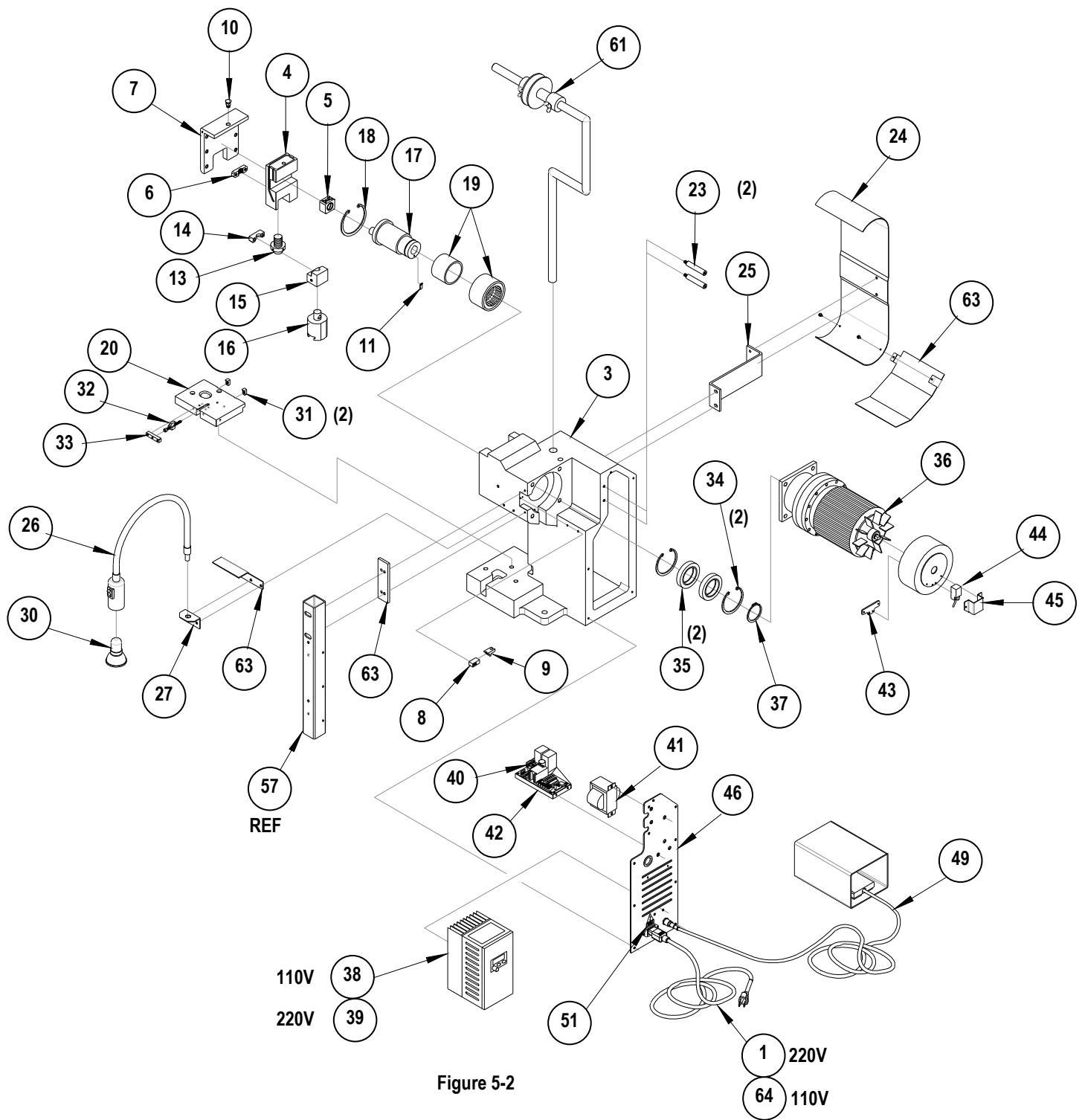
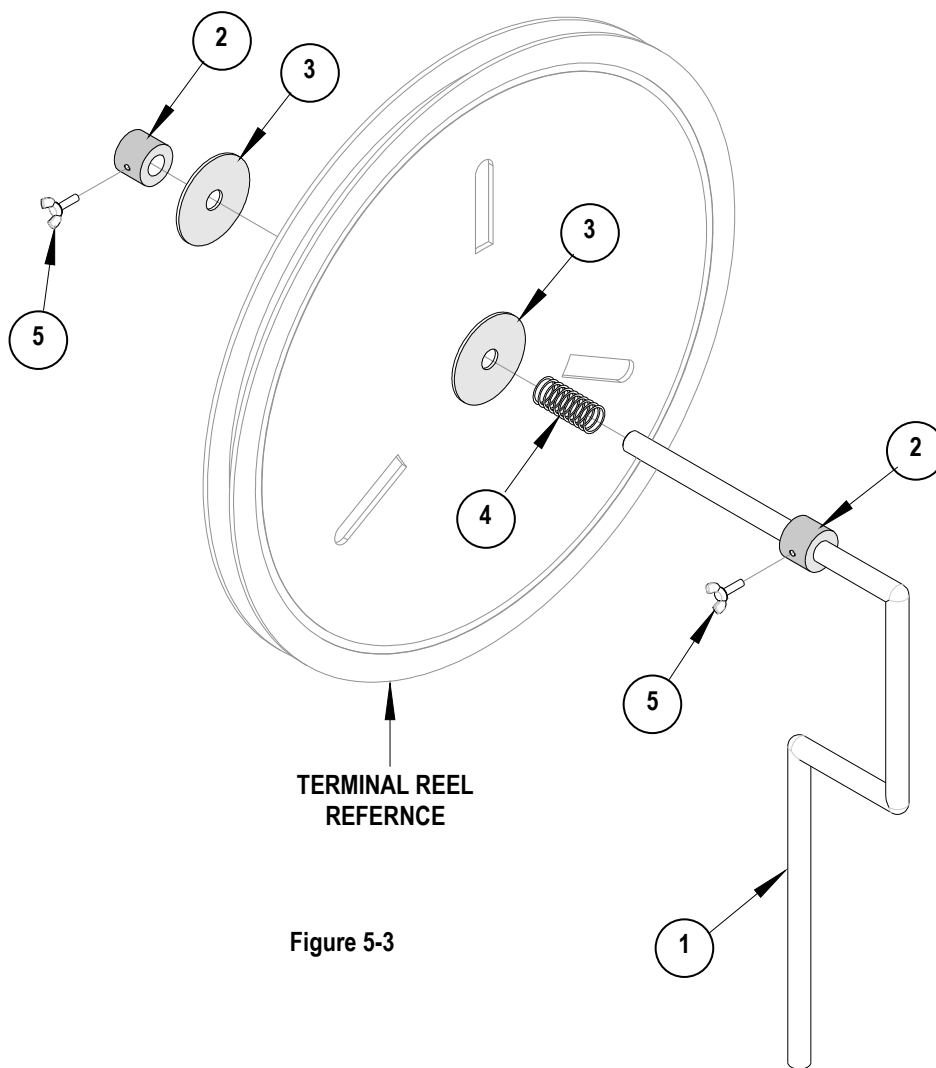

Figure 5-2

### Reel Support Parts List

Reel Support Assembly 63801-7290				
Item No.	Order No.	Engineering No.	Description	Quantity
1	63801-7260	63801-7260	Reel Support	1
2	63801-7261	63801-7261	Reel Boss	2
3	63801-7262	63801-7262	Reel Disc	2
4	63801-7263	63801-7263	Reel-Spring	1
Hardware				
5	N/A	N/A	M6 by 16 Long Wing Screw	2**
** Available from an industrial supply company such as MSC (1-800-645-7270).				

### Reel Support Assembly



**Safety Guard Parts List**

<b>Safety Guard Assembly 64016-2590</b>				
<b>Item No.</b>	<b>Order No.</b>	<b>Engineering No.</b>	<b>Description</b>	<b>Quantity</b>
1	63700-2342	63700-2342	Label-Caution(Eye Glasses)	1
2	63700-2344	63700-2344	Label-Caution(Guard In Place)	1
3	63801-7212	63801-7212	Handle, Guard	1
4	63801-7279	63801-7279	Terminal Guide Standoff	4
5	63801-7287	63801-7287	Bracket Guard	1
6	64016-2521	64016-2521	Guard, Front	1
7	64016-2522	64016-2522	Terminal Guide, Lower	1
8	64016-2523	64016-2523	Mounting Bracket	8
9	64016-2537	64016-2537	Guard, Point Of Operation	1
10	64016-2541	64016-2541	Guard, Right	1
11	64016-2579	64016-2579	Spacer Plate	1
12	64016-2581	64016-2581	Guard	1
13	64016-2586	64016-2586	Guard Rear	1
<b>Hardware</b>				
14	N/A	N/A	M4 by 8 Long BHCS	10**
15	N/A	N/A	M4 by 10 Long BHCS	16**
16	N/A	N/A	M6 by 12 Long SHCS	4*
17	N/A	N/A	M6 by 16 Long SHCS	2**
** Available from an industrial supply company such as MSC (1-800-645-7270).				

### Safety Guard Assembly

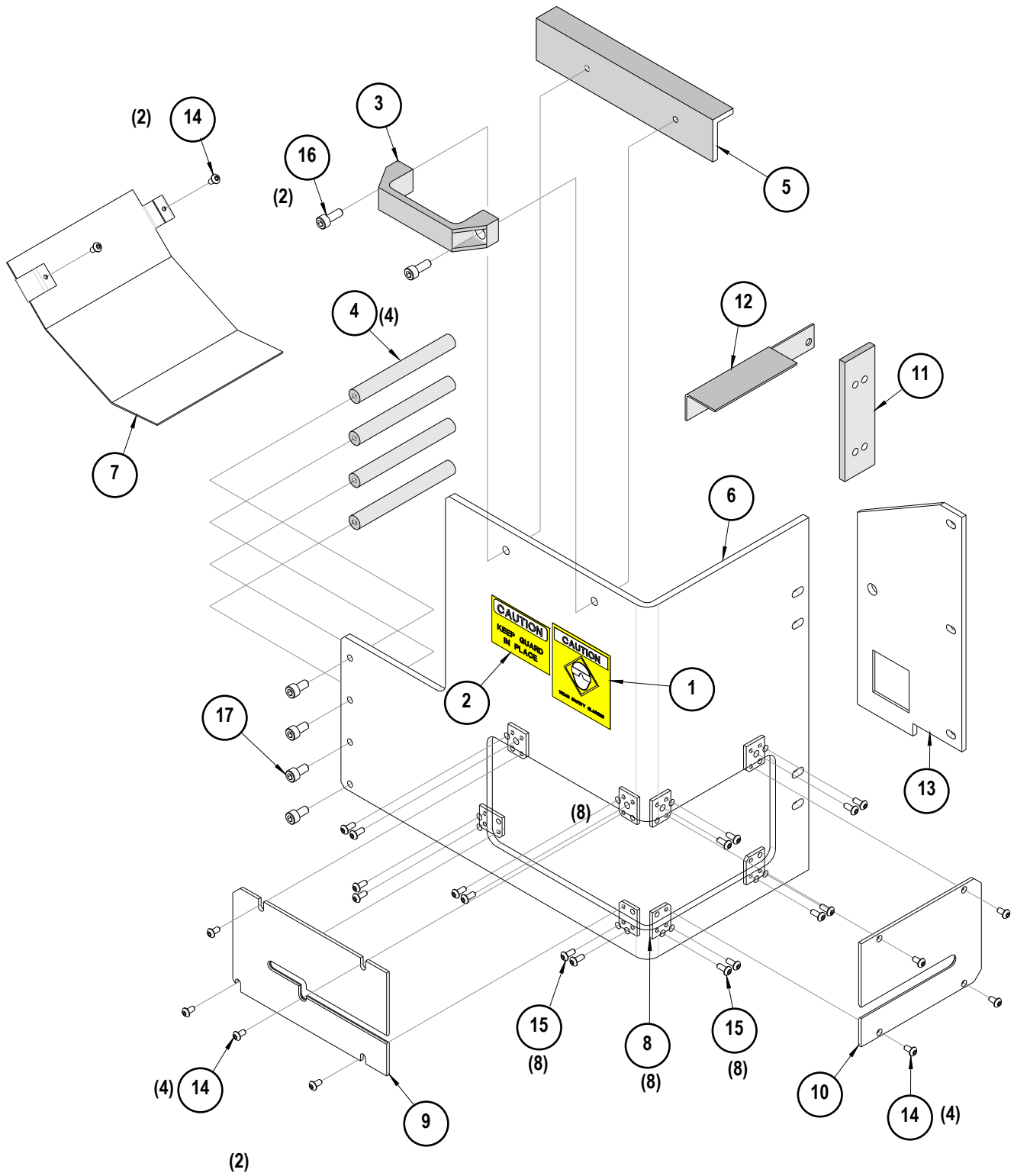
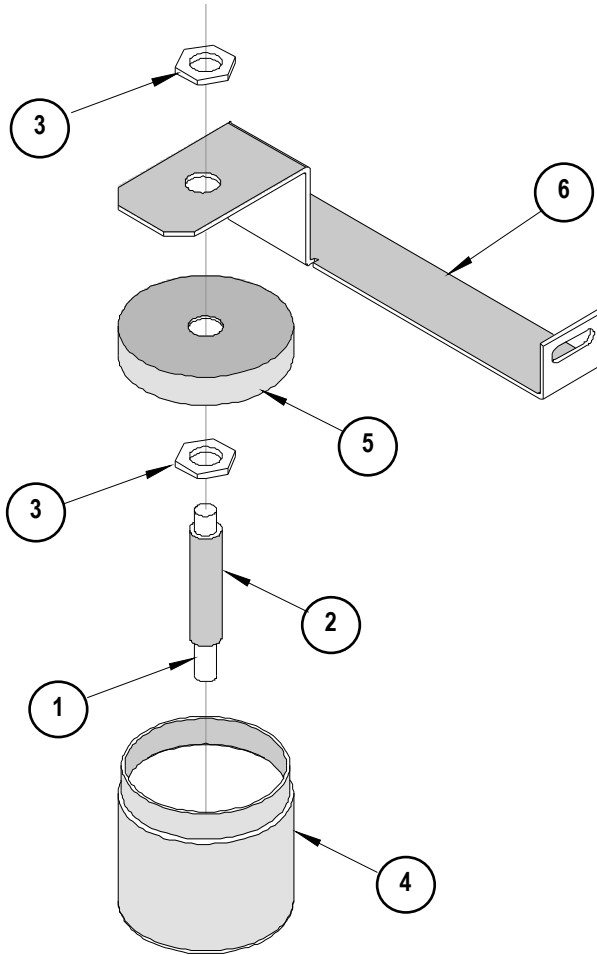

Figure 5-4

**Oiler Assembly**



**Figure 5-3**

**Oiler Assembly  
Item No. 43 (63801-7240)**

Item No.	Description	Quantity
1	Oiler Wick	1
2	Oiler Lamp Tube	1
3	Oiler Lamp Tube Nut	2
4	Wide Mouth Glass Jar	1
5	Oiler Glass Jar Lid	1
6	Oiler Bracket	1



5.3. Electrical Schematic

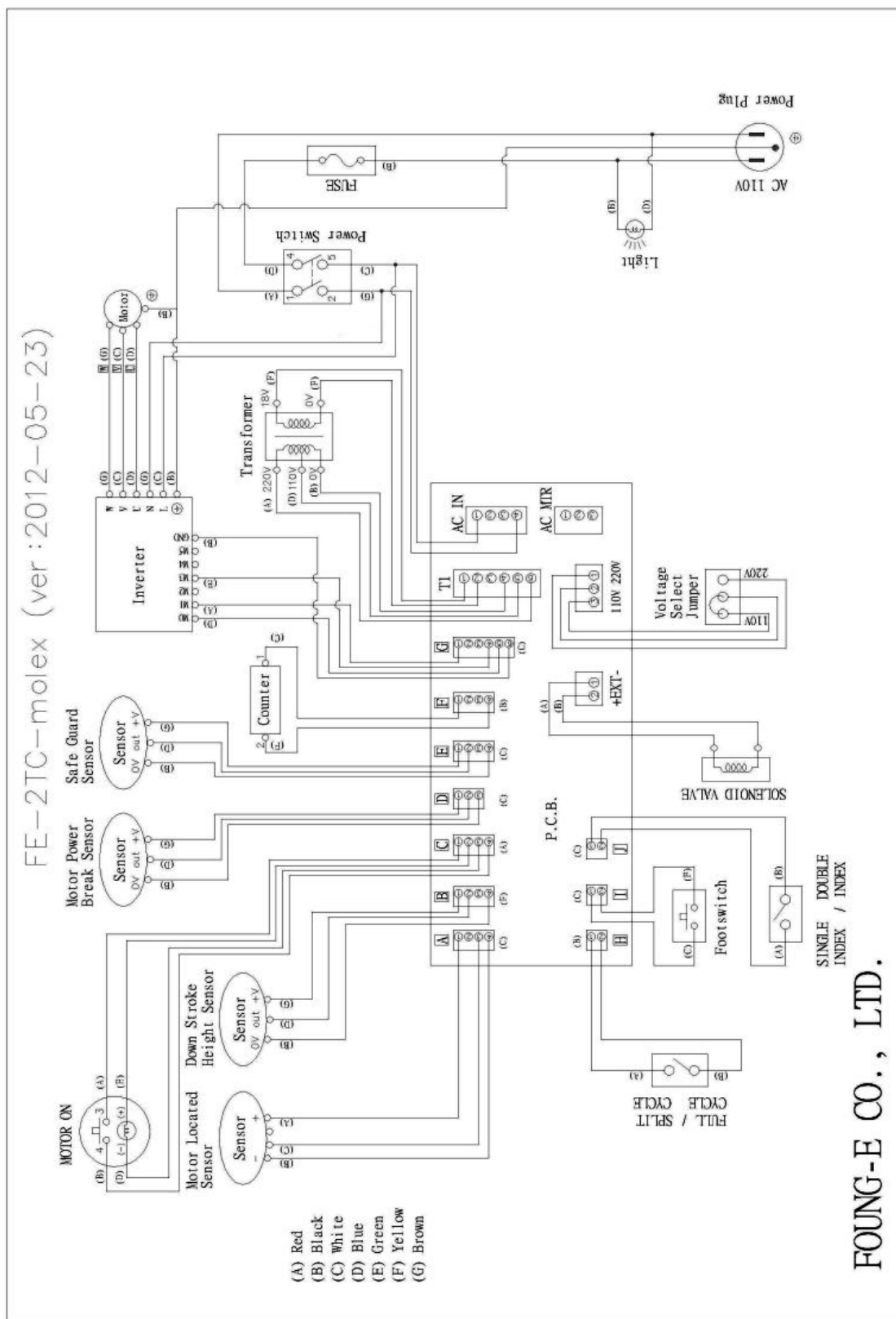

### 5.3. Pnuematic Schematic

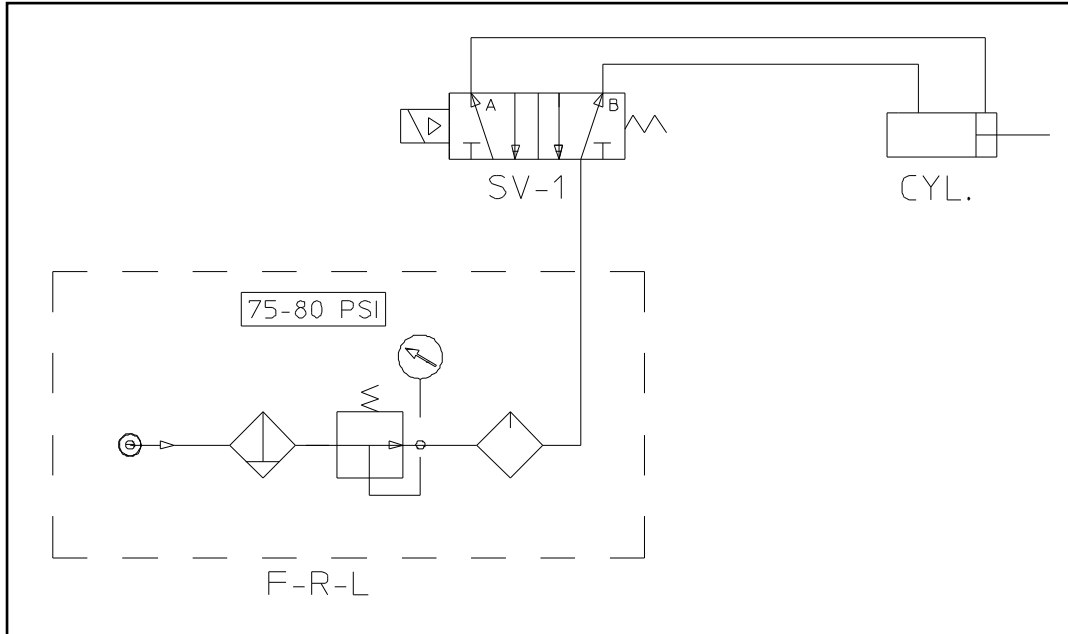

Figure 5-5

## Section 6

### 6.1 EC Declaration of Conformity

EC Declaration of Conformity

We hereby declare that the following product is in conformity with the requirements of the following EC Directives:

Product:	Termination Machine
Type:	TM-3000
Title and No. Of Directive:	
Machinery Directive	98/37/EC
Low Voltage Directive	73/23/EEC
EMC Directive	89/336/EEC

Provided that it is used and maintained in accordance with the general accepted codes of good practice and the recommendations of the instructions manual, meets the essential safety and health requirements of the Machinery Directive, Low Voltage Directive and Electromagnetic Compatibility Directive. For the most specific risks of this machine, safety and compliance with the essential requirements of the Directive has been based on elements of:

- . EN ISO 12100-1 : 2003 / Safety of Machinery - Basic concepts, general principles for design - Part 1 : Basic terminology, methodology.
- . EN ISO 12100-2 : 2003 / Safety of Machinery - Basic concepts, general principles for design - Part 2 : Technical principles and specifications.
- . EN 294 : 1992 / Safety of machinery - Safety distance to prevent danger zones being reached by the upper limbs
- . EN 418: 1992 / Safety of machinery - Emergency stop equipment, functional aspects - Principles for design
- . EN 1037 : 1995 / Safety of machinery - Prevention of unexpected start-up
- . EN 1050 : 1996 / Safety of machinery - Principles for risk assessment
- . EN 60204-1 : 1997 / Safety of machinery - Electrical equipment of machines - Part 1 : General requirements.
- . EN 55011: 1998 / Limits and methods of measurement of radio interference characteristics of industrial electrical device.
- . EN 61000-6-2 : 2001 / Electromagnetic compatibility (EMC) Part 6-2 : Generic standards . Immunity for industrial environments
- . EN 61000-6-4 : 2001 / Electromagnetic compatibility (EMC) Part 6-4 : Generic standards . Emission standard for industrial environments

Supplier Name:	Molex Application Tooling Group
Address:	2200 Wellington Ct. Lisle, Il. 60532 USA
Date:	June 19, 2007
Signed:	<u>Hasmukh Shah</u>
Typed Name:	Hasmukh Shah
Title:	Engineering Group Manager.

### For more information use the Quality Crimping Handbook And Industrial Crimping Handbook

There is no charge for these books, they can be found on the Molex Website ([www.molex.com](http://www.molex.com)) or contact your local Molex sales engineer

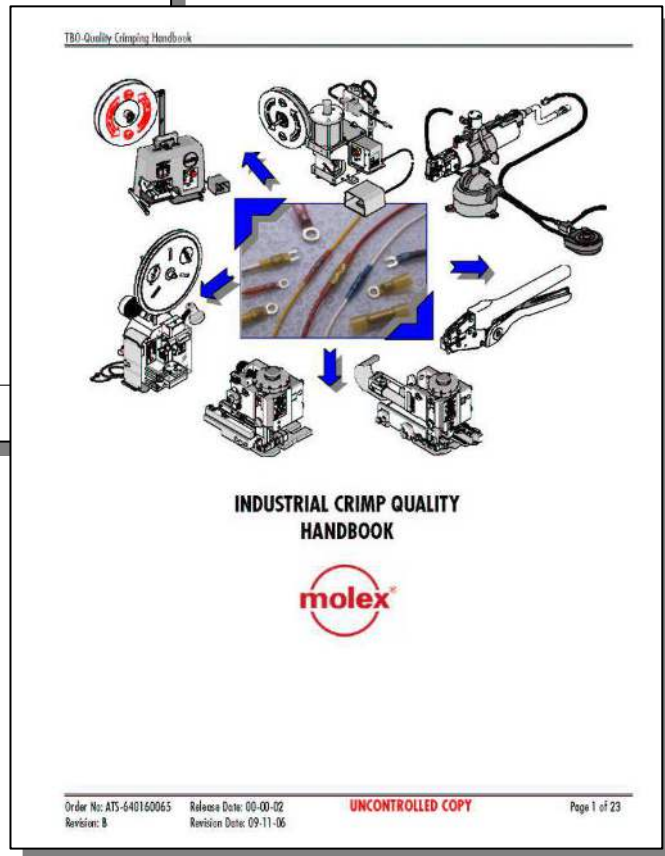
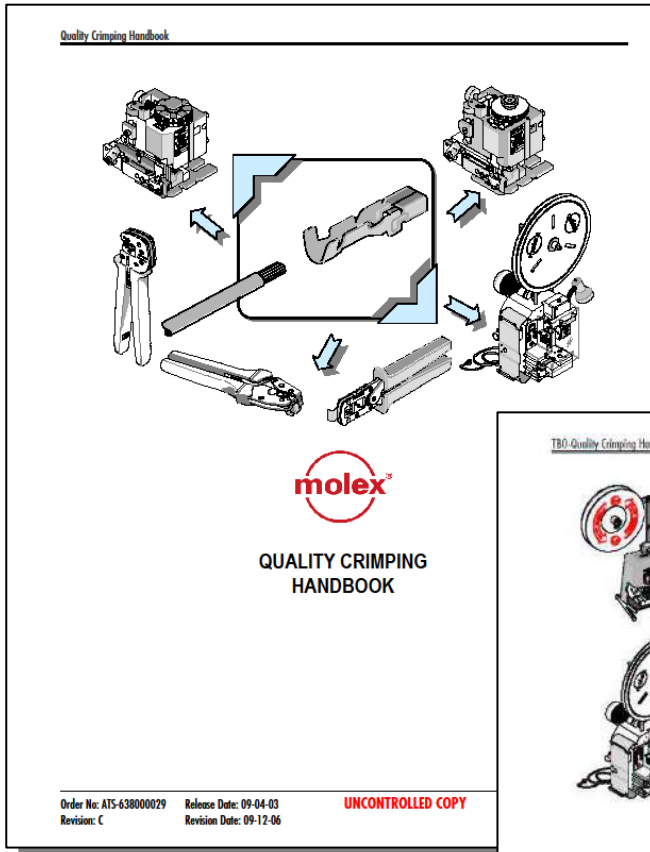

Visit our Web site at <http://www.molex.com>