

ASM6-Sxxx-xxxxH

3W 3535 Surface-Mount LED



Description

The Broadcom[®] ASM6 LED series, a proliferation from the earlier ASM3 series, are the latest high-power LEDs development edition. While maintaining a similar 3535 footprint, the ASM6 series exhibits higher lumen output and displays better cost per lumen ratio. This new ASM6 family is energy efficient and adapts good heat sink properties. It is also superior in package robustness and better product longevity with its silicone encapsulation.

Features

- High reliability package with enhanced silicone resin encapsulation
- Available in Far Red, Deep Red, Red, Royal Blue, Blue, and Green
- Available in 90° and 130° viewing angles
- Compatible with reflow soldering process
- JEDEC MSL 1

Applications

- Horticulture lighting
- Commercial lighting
- Architecture lighting
- Specialty lighting

CAUTION! This LED is ESD sensitive. Please observe appropriate precautions during handling and processing. Refer to the *Premium InGaN LEDs: Safety Handling Fundamentals ESD*, Application Note AN-1142, for additional details.

Figure 1: Package Drawing

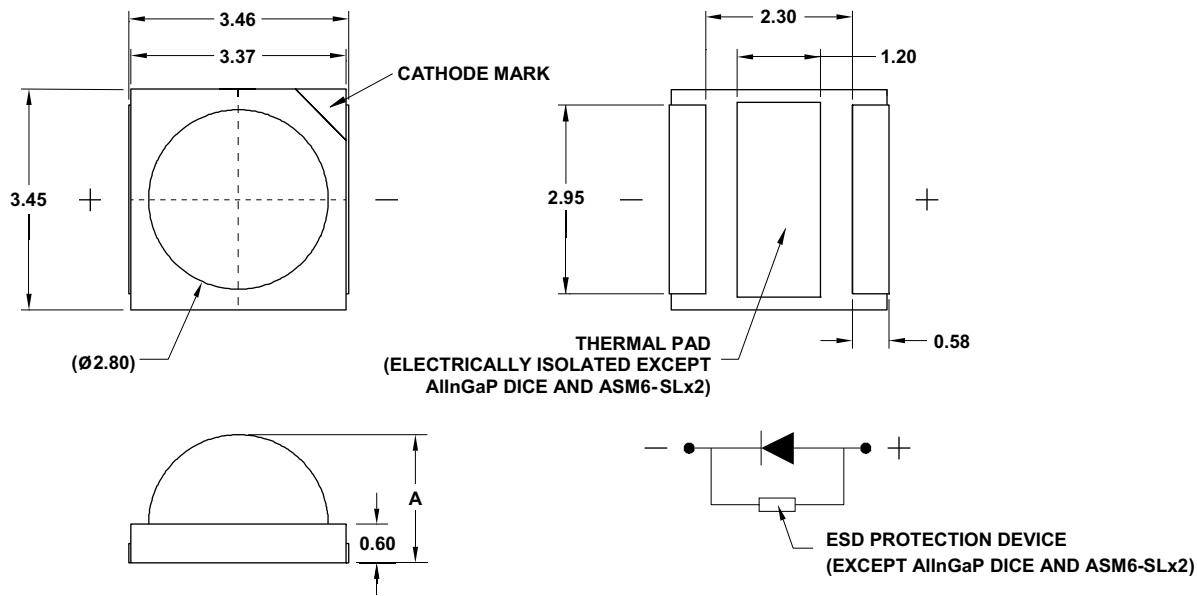

Part Number	Dimension A (mm)
ASM6-SxDx-xxxxH	1.90
ASM6-Sx9x-xxxxH	2.50

NOTE:

1. All dimensions are in millimeters (mm).
2. Tolerance is ± 0.20 mm unless otherwise specified.
3. Thermal pad is connected to anode for AlInGaP dice and ASM6-SLD2.
4. Encapsulation = silicone.
5. Terminal finish = silver plating.
6. Dimensions in parentheses are for reference only.

Device Selection Guide ($T_J = 25^\circ\text{C}$, $I_F = 350\text{ mA}$)

Part Number	Color	Viewing Angle, $2\theta_{1/2}$ ($^\circ$) ^a	Radiant Flux, Φ_e (mW) ^{b, c}			PPF, Φ_p ($\mu\text{mol/s}$) ^{d, e}	PPF/W ($\mu\text{mol/J}$)	Dice Technology
		Typ.	Min.	Typ.	Max.	Typ.	Typ.	
ASM6-S390-ANQ0H	Far Red	90	330.0	350.0	480.0	2.11 ^f	2.87	AllnGaP
ASM6-SD90-AQR0H	Deep Red	90	430.0	450.0	530.0	2.44	3.32	AllnGaP
ASM6-SD91-AQS0H	Deep Red	90	450.0	500.0	600.0	2.82	3.84	AllnGaP
ASM6-SL91-NST0H	Royal Blue	90	530.0	580.0	705.0	2.18	2.15	InGaN
ASM6-SL92-NTV0H	Royal Blue	90	610.0	730.0	930.0	2.76	2.72	InGaN
ASM6-S3D0-ANQ0H	Far Red	130	330.0	350.0	480.0	2.11 ^f	2.87	AllnGaP
ASM6-SDD0-AQR0H	Deep Red	130	430.0	450.0	530.0	2.44	3.32	AllnGaP
ASM6-SDD1-AQS0H	Deep Red	130	450.0	500.0	600.0	2.82	3.84	AllnGaP
ASM6-SLD1-NST0H	Royal Blue	130	530.0	580.0	705.0	2.18	2.15	InGaN
ASM6-SLD2-NTV0H	Royal Blue	130	610.0	730.0	930.0	2.76	2.72	InGaN

Part Number	Color	Viewing Angle, $2\theta_{1/2}$ ($^\circ$) ^a	Luminous Flux, Φ_v (lm) ^{b, c}			PPF, Φ_p ($\mu\text{mol/s}$) ^{d, e}	PPF/W ($\mu\text{mol/J}$)	Dice Technology
		Typ.	Min.	Typ.	Max.	Typ.	Typ.	
ASM6-SR90-AHK0H	Red	90	50.0	62.0	78.0	1.45	1.88	AllnGaP
ASM6-SR91-AKM0H	Red	90	67.3	75.0	105.0	1.97	2.73	AllnGaP
ASM6-SB93-NGJ0H	Blue	90	39.1	45.0	67.3	1.85	1.82	InGaN
ASM6-SG91-NQT0H	Green	90	127.0	145.0	186.0	1.32	1.30	InGaN
ASM6-SRD0-AHK0H	Red	130	50.0	62.0	78.0	1.45	1.88	AllnGaP
ASM6-SRD1-AKM0H	Red	130	67.3	75.0	105.0	1.97	2.73	AllnGaP
ASM6-SBD3-NGJ0H	Blue	130	39.1	45.0	67.3	1.85	1.82	InGaN
ASM6-SGD1-NRT0H	Green	130	140.0	145.0	186.0	1.32	1.30	InGaN

a. $\theta_{1/2}$ is the off-axis angle where the luminous intensity is half of the peak intensity.

b. Radiant flux, Φ_e /Luminous flux, Φ_v is the total output measured with an integrating sphere at a single current pulse condition.

c. Radiant flux, Φ_e /Luminous flux, Φ_v tolerance is $\pm 10\%$.

d. Photosynthetic Photon Flux (PPF), Φ_p , is the measurement of Photosynthetically Active Radiation (PAR) ranging from 400 nm to 700 nm.

e. Values are calculated and for reference only.

f. Plant Biologically Active Radiation Flux (PBAR) for Far Red is measured from 280 nm to 800 nm.

Absolute Maximum Ratings

Parameters	Royal Blue, Blue, and Green	Deep Red and Far Red	Red (ASM6-SRx1)	Red (ASM6-SRx0)	Units
DC Forward Current ^a	1000	1000	1000	700	mA
Peak Forward Current ^b	2000	2000	2000	2000	mA
Power Dissipation	3400	2600	1960	1960	mW
Reverse Voltage	Not designed for reverse bias operation				
LED Junction Temperature	125	125	125	125	°C
Operating Temperature Range	-40 to +120	-40 to +120	-40 to +120	-40 to +120	°C
Storage Temperature Range	-40 to +120	-40 to +120	-40 to +120	-40 to +120	°C

a. Derate linearly as shown in Figures 22, 23, 24, 25, 26, and 27.

b. Duty factor = 10%, frequency = 1 kHz.

Optical and Electrical Characteristics ($T_J = 25^\circ\text{C}$, $I_F = 350\text{ mA}$)

Color	Peak Wavelength, λ_p (nm)			Forward Voltage, V_F (V) ^a			Thermal Resistance, $R_{\theta J-S}$ (°C/W) ^b
	Min.	Typ.	Max.	Min.	Typ.	Max.	Typ.
Far Red	720	735	745	1.8	2.1	2.6	3
Deep Red	650	655	670	1.8	2.1	2.6	3
Royal Blue	440	450	460	2.6	2.9	3.4	3

Color	Dominant Wavelength, λ_d (nm)			Forward Voltage, V_F (V) ^a			Thermal Resistance, $R_{\theta J-S}$ (°C/W) ^b
	Min.	Typ.	Max.	Min.	Typ.	Max.	Typ.
Red	617	625	635	1.8	2.2	2.8	4
Blue	460	470	485	2.6	2.9	3.4	4
Green	515	525	535	2.6	2.9	3.4	6

a. Forward voltage, V_F , tolerance is $\pm 0.1\text{V}$.

b. Thermal resistance from the LED junction to the solder point.

Performance Characteristics ($T_J = 25^\circ\text{C}$, $I_F = 700\text{ mA}$)

Part Number	Color	Viewing Angle, $2\theta_{1/2}$ ($^\circ$)	Radiant Flux, Φ_e (mW)	PPF, Φ_P ($\mu\text{mol/s}$)	Forward Voltage, V_F (V)
		Typ.	Typ.	Typ.	Typ.
ASM6-S390-ANQ0H	Far Red	90	693	4.18	2.4
ASM6-SD90-AQR0H	Deep Red	90	891	4.83	2.5
ASM6-SD91-AQS0H	Deep Red	90	945	5.33	2.3
ASM6-SL91-NST0H	Royal Blue	90	1148	4.32	3.2
ASM6-SL92-NTV0H	Royal Blue	90	1445	5.46	3.1
ASM6-S3D0-ANQ0H	Far Red	130	693	4.18	2.4
ASM6-SDD0-AQR0H	Deep Red	130	891	4.83	2.5
ASM6-SDD1-AQV0H	Deep Red	130	945	5.33	2.3
ASM6-SLD1-NST0H	Royal Blue	130	1148	4.32	3.2
ASM6-SLD2-NTV0H	Royal Blue	130	1445	5.46	3.1

Part Number	Color	Viewing Angle, $2\theta_{1/2}$ ($^\circ$)	Luminous Flux, Φ_v (lm)	PPF, Φ_P ($\mu\text{mol/s}$)	Forward Voltage, V_F (V)
		Typ.	Typ.	Typ.	Typ.
ASM6-SR90-AHK0H	Red	90	111	2.60	2.5
ASM6-SR91-AKM0H	Red	90	133	3.72	2.5
ASM6-SB93-NGJ0H	Blue	90	76	3.11	3.2
ASM6-SG91-NQT0H	Green	90	231	2.10	3.3
ASM6-SRD0-AHK0H	Red	130	111	2.60	2.5
ASM6-SRD1-AKM0H	Red	130	133	3.72	2.5
ASM6-SBD3-NGJ0H	Blue	130	76	3.11	3.2
ASM6-SGD1-NRT0H	Green	130	231	2.10	3.3

Part Numbering System

A S M 6 - S

x ₁	x ₂	x ₃
----------------	----------------	----------------

 -

x ₄	x ₅	x ₆	x ₇	x ₈
----------------	----------------	----------------	----------------	----------------

Code	Description	Option	
x ₁	Color	3	Far Red
		D	Deep Red
		G	Green
		B	Blue
		L	Royal Blue
		R	Red
x ₂	Viewing Angle	D	130°
		9	90°
x ₃	Internal Code		
x ₄	Dice Technology	A	AllnGaP
		N	InGaN
x ₅	Minimum Flux Bin	See Luminous Flux Bin Limits (CAT) and Radiant Flux Bin Limits (CAT)	
x ₆	Maximum Flux Bin		
x ₇	Color Bin Option	0	Full Distribution
x ₈	Test Option	H	Test Current = 350 mA

Part Number Example

ASM6-S3D0-ANQ0H

- x₁: 3 – Far Red color
- x₂: D – 130° viewing angle
- x₄: A – AllnGaP dice
- x₅: N – Minimum radiant flux bin N
- x₆: Q – Maximum radiant flux bin Q
- x₇: 0 – Full color distribution
- x₈: H – Test current = 350 mA

Bin Information

Luminous Flux Bin Limits (CAT)

Bin ID	Luminous Flux, Φ_V (lm)	
	Min.	Max.
Red and Green		
G	39.1	50.0
H	50.0	58.0
J	58.0	67.3
K	67.3	78.0
L	78.0	90.5
M	90.5	105.0
N	105.0	115.0
P	115.0	127.0
Q	127.0	140.0
R	140.0	154.0
S	154.0	169.0
T	169.0	186.0

Tolerance = $\pm 10\%$.

Radiant Flux Bin Limits (CAT)

Bin ID	Radiant Flux, Φ_e (mW)	
	Min.	Max.
Far Red, Royal Blue, and Deep Red (ASM6-SDx0)		
N	330	380
P	380	430
Q	430	480
R	480	530
S	530	610
T	610	705
U	705	810
V	810	930
Deep Red (ASM6-SDx1)		
Q	450	500
R	500	550
S	550	600

Tolerance = $\pm 10\%$.

Color Bin Limits (BIN)

Bin ID	Peak Wavelength, λ_p (nm)	
	Min.	Max.
Royal Blue		
3	440	445
4	445	450
5	450	455
6	455	460
Deep Red		
—	650	670
Far Red		
—	720	745

Bin ID	Dominant Wavelength, λ_d (nm)	
	Min.	Max.
Blue		
3	460	465
4	465	470
5	470	475
6	475	480
7	480	485
Green		
1	515	520
2	520	525
3	525	530
4	530	535
Red		
—	617	635

Tolerance = ± 1.0 nm.

Forward Voltage Limits (V_F)

Bin ID	Forward Voltage, V_F (V)	
	Min.	Max.
1	1.8	2.0
2	2.0	2.2
3	2.2	2.4
4	2.4	2.6
5	2.6	2.8
6	2.8	3.0
7	3.0	3.2
8	3.2	3.4

Tolerance = $\pm 0.1V$.

Example

Example of bin information on reel and packaging label:

CAT: P – Luminous / Radiant Flux bin P
 BIN: — – Full distribution color bin
 VF: 4 – Forward Voltage bin 4

Figure 2: Spectral Power Distribution – Royal Blue, Blue, Green, Far Red, Deep Red, and Red

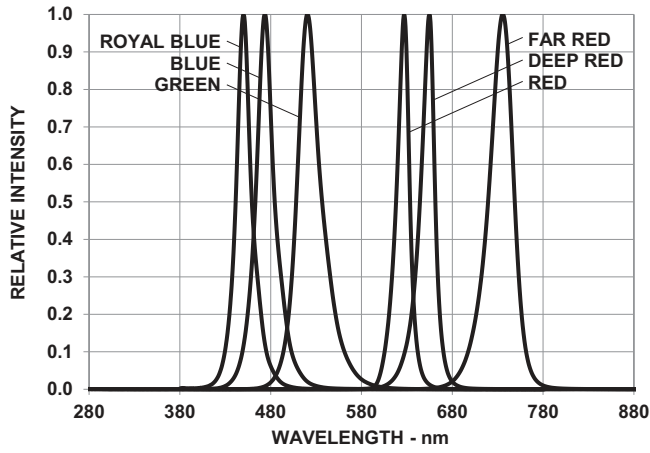

Figure 3: Forward Current vs. Forward Voltage – Royal Blue, Blue, and Green

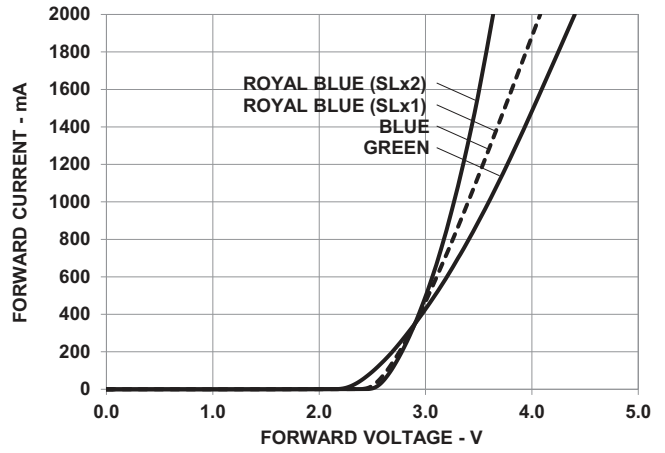

Figure 4: Forward Current vs. Forward Voltage – Far Red and Deep Red

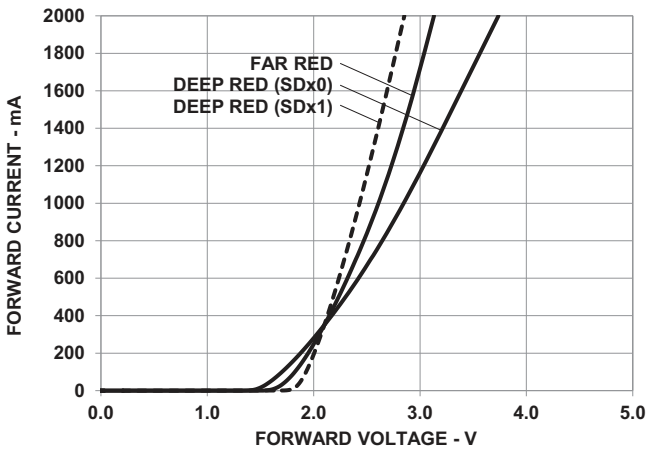

Figure 5: Forward Current vs. Forward Voltage – Red

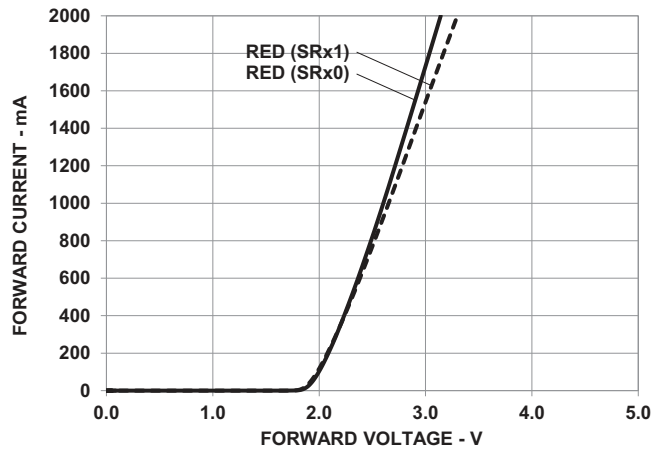

Figure 6: Relative Luminous Flux vs. Mono Pulse Current – Red (ASM6-SRx1)

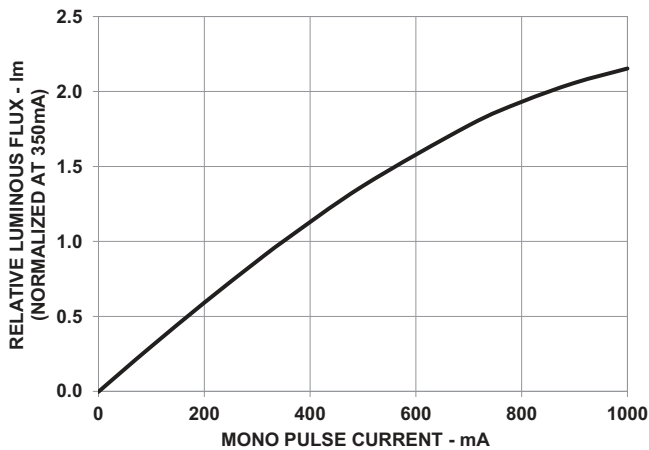

Figure 7: Relative Luminous Flux vs. Mono Pulse Current – Red (ASM6-SRx0)

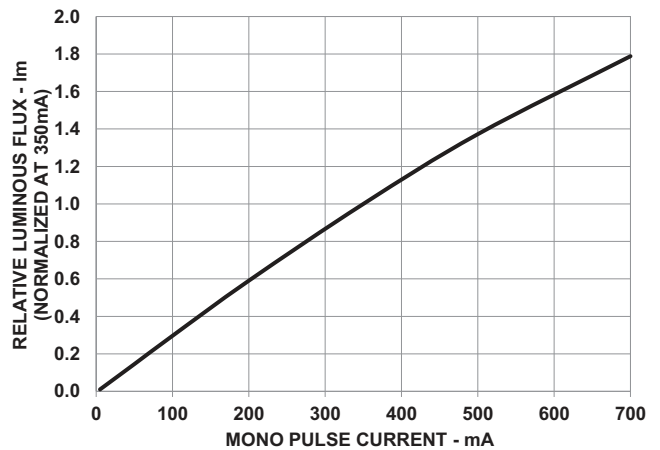

Figure 8: Relative Luminous Flux vs. Mono Pulse Current – Blue and Green

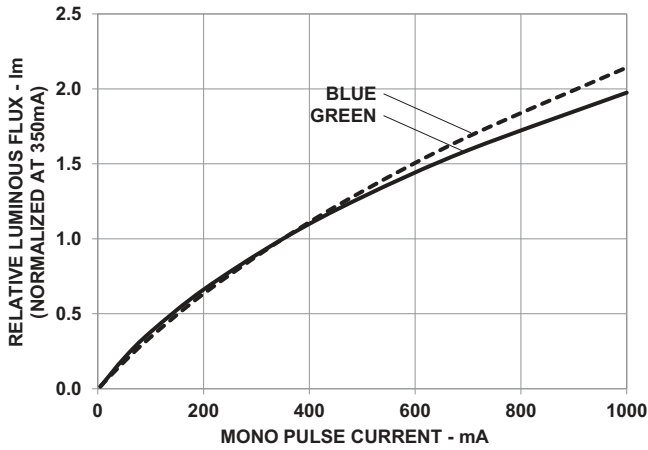

Figure 9: Relative Radiant Flux vs. Mono Pulse Current – Royal Blue, Far Red, and Deep Red

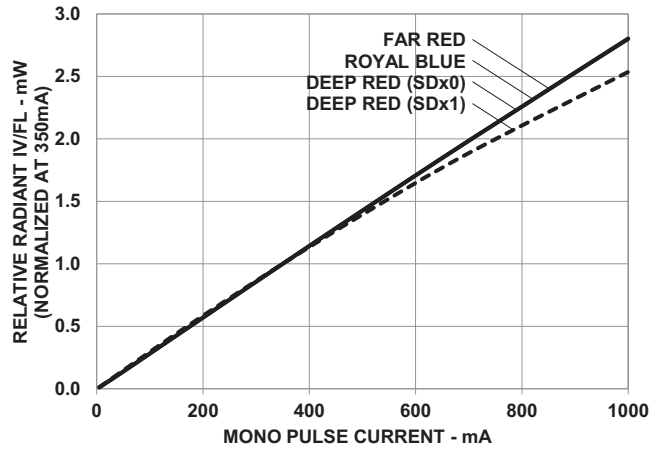

Figure 10: Dominant Wavelength Shift vs. Mono Pulse Current – Blue, Green, and Red (ASM6-SRx1)

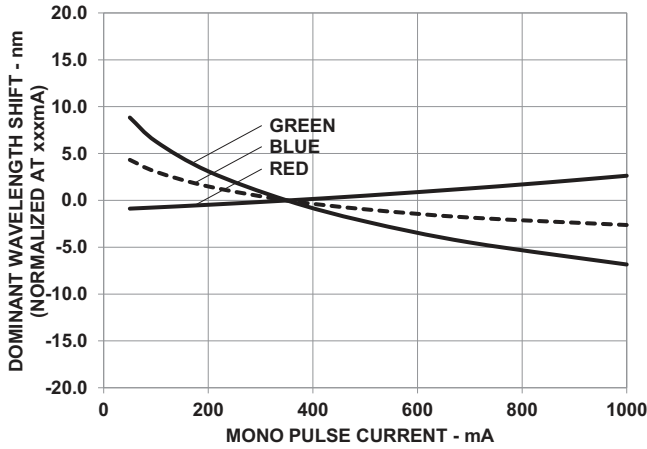

Figure 11: Dominant Wavelength Shift vs. Mono Pulse Current – Red (ASM6-SRx0)

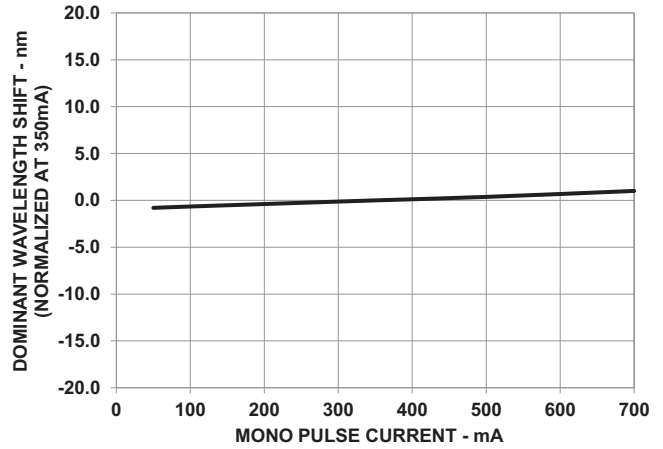

Figure 12: Peak Wavelength Shift vs. Mono Pulse Current – Far Red, Deep Red, and Royal Blue

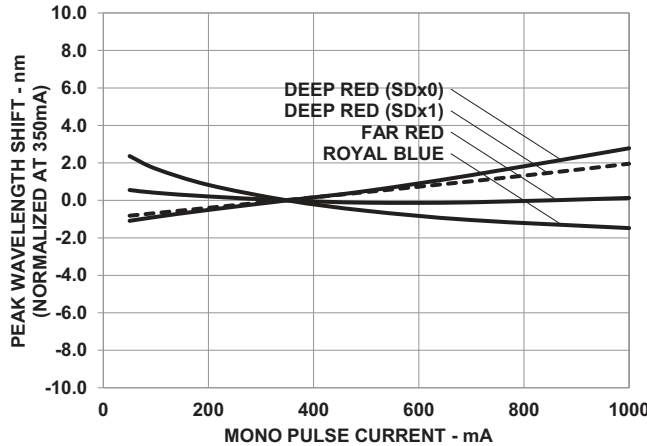

Figure 13: Relative Light Output vs. Junction Temperature – Blue, Green, and Red

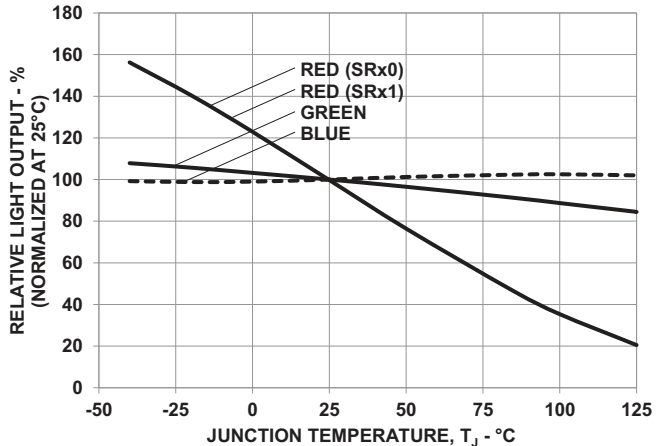

Figure 14: Relative Radiant Output vs. Junction Temperature – Royal Blue, Far Red, and Deep Red

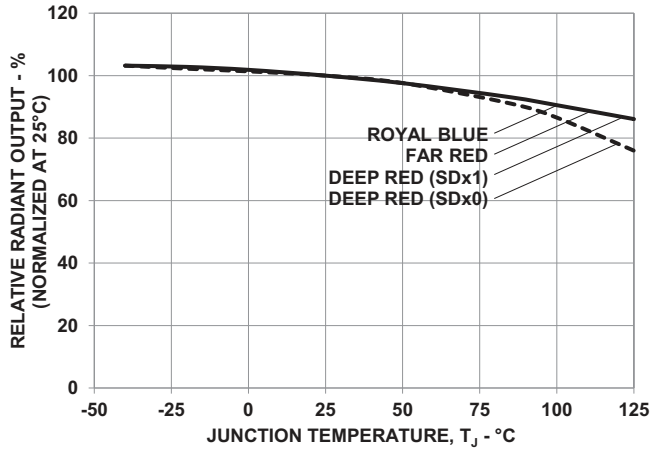

Figure 15: Forward Voltage Shift vs. Junction Temperature – Royal Blue, Blue, and Green

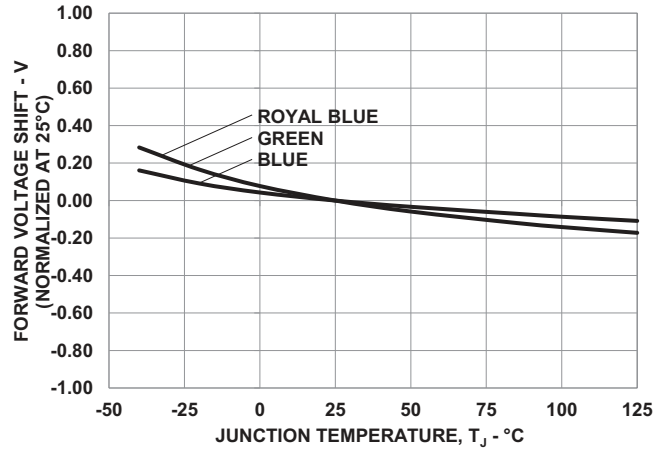

Figure 16: Forward Voltage Shift vs. Junction Temperature – Far Red, Deep Red, and Red

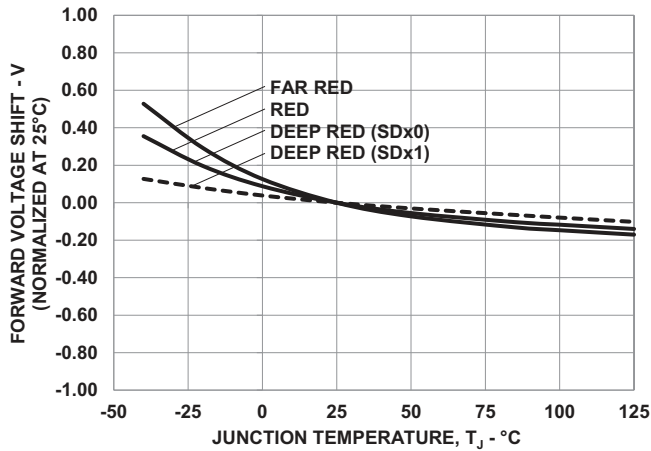

Figure 17: Dominant Wavelength Shift vs. Junction Temperature – Blue, Green, and Red

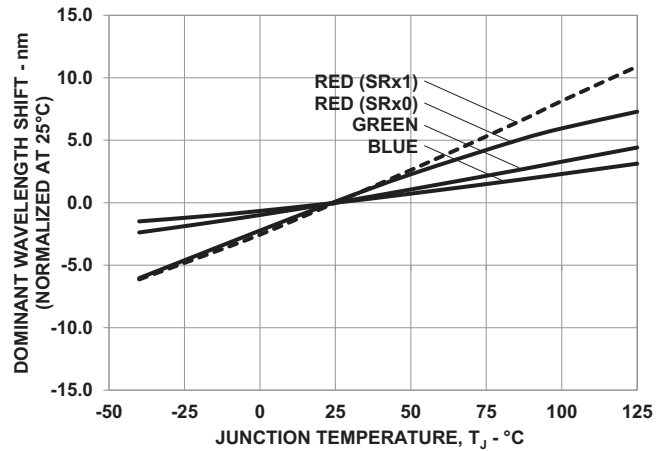

Figure 18: Peak Wavelength Shift vs. Junction Temperature – Far Red, Deep Red, and Royal Blue

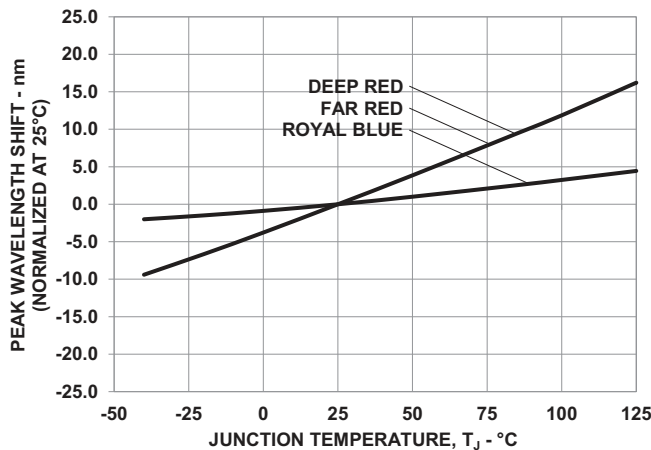

Figure 19: Radiation Pattern 90°

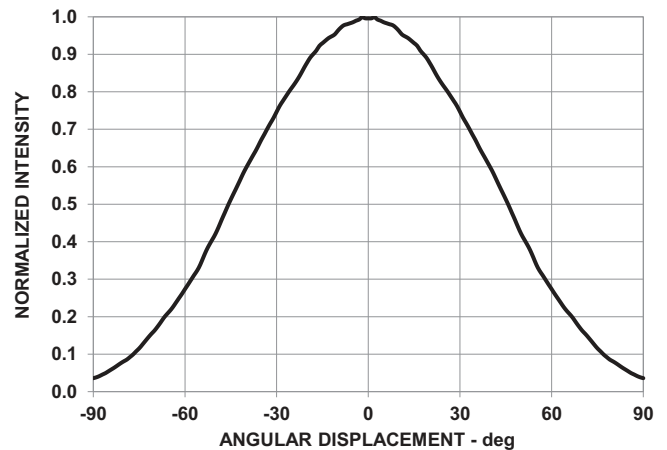

Figure 20: Radiation Pattern 130° – Royal Blue, Blue, and Green

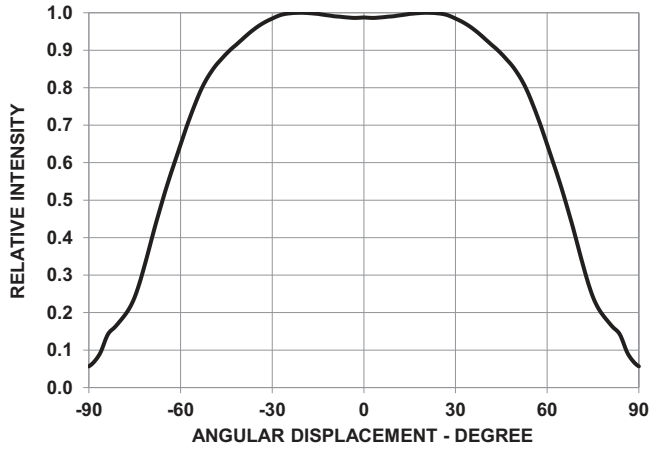

Figure 21: Radiation Pattern 130° – Far Red, Deep Red, and Red

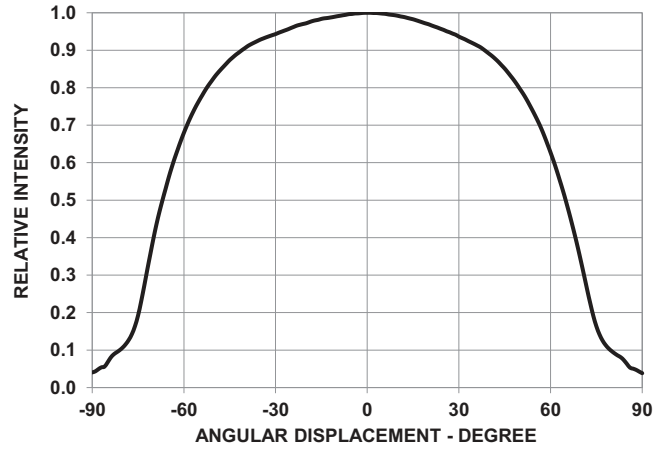

Figure 22: Maximum Forward Current vs. Ambient Temperature – Royal Blue, Blue, and Green

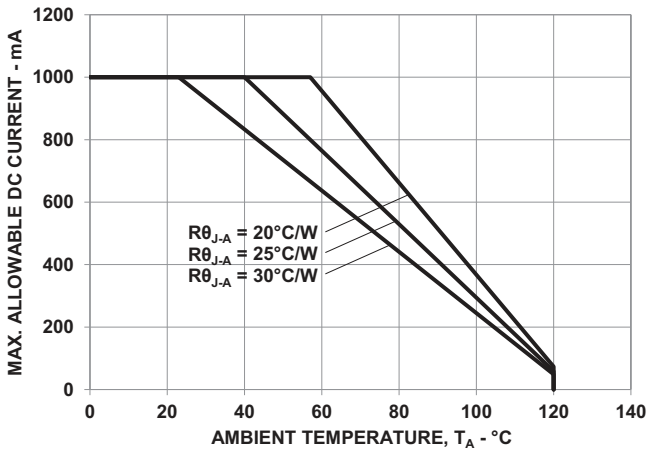

Figure 23: Maximum Forward Current vs. Ambient Temperature – Far Red and Deep Red

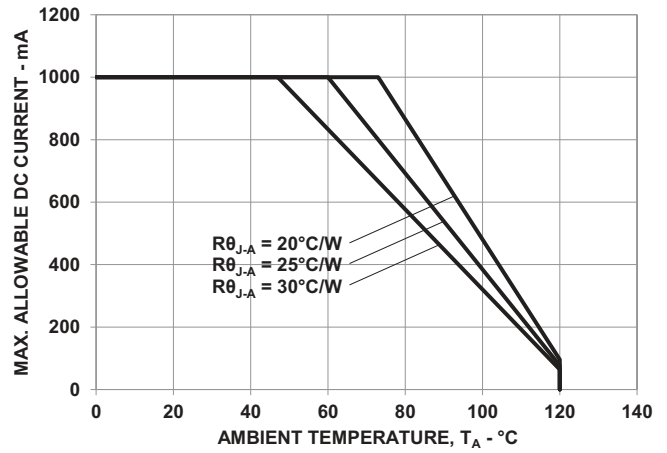

Figure 24: Maximum Forward Current vs. Ambient Temperature – Red

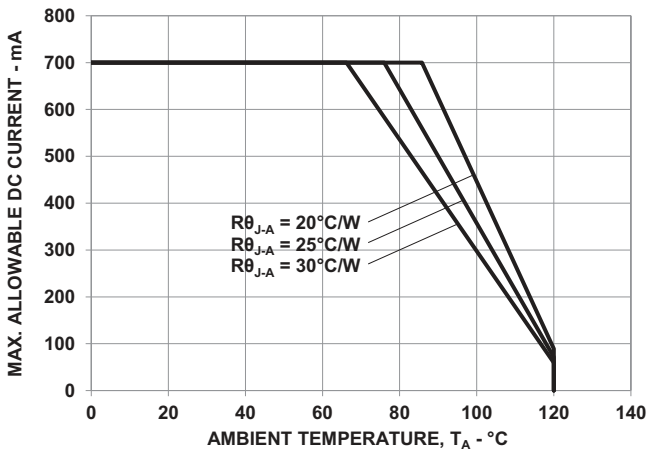

Figure 25: Maximum Forward Current vs. Solder Point Temperature – Royal Blue, Blue, and Green

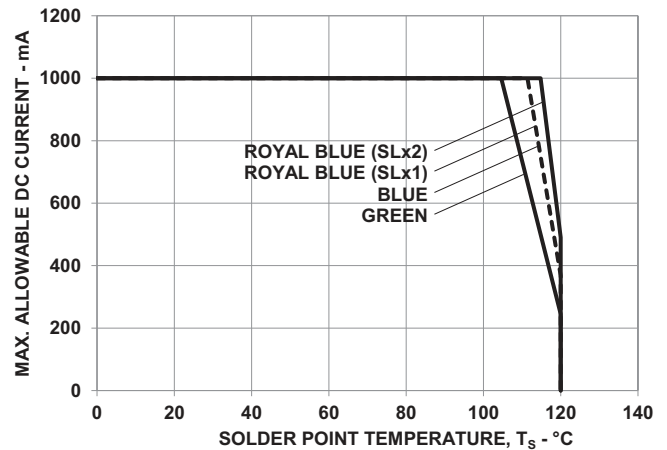

Figure 26: Maximum Forward Current vs. Solder Point Temperature – Far Red and Deep Red

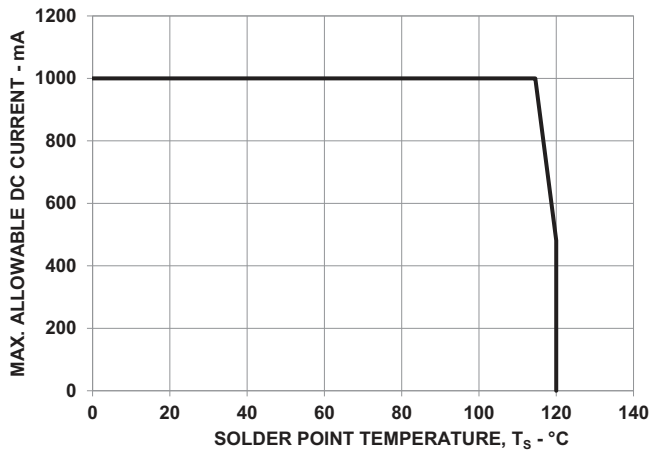

Figure 27: Maximum Forward Current vs. Solder Point Temperature – Red

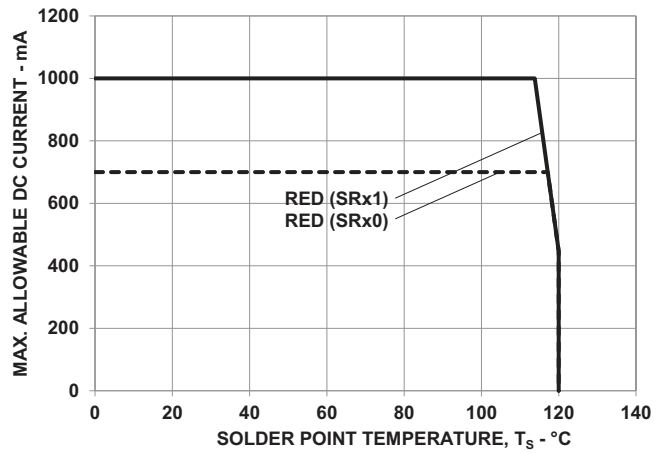

Figure 28: Recommended Soldering Land Pattern

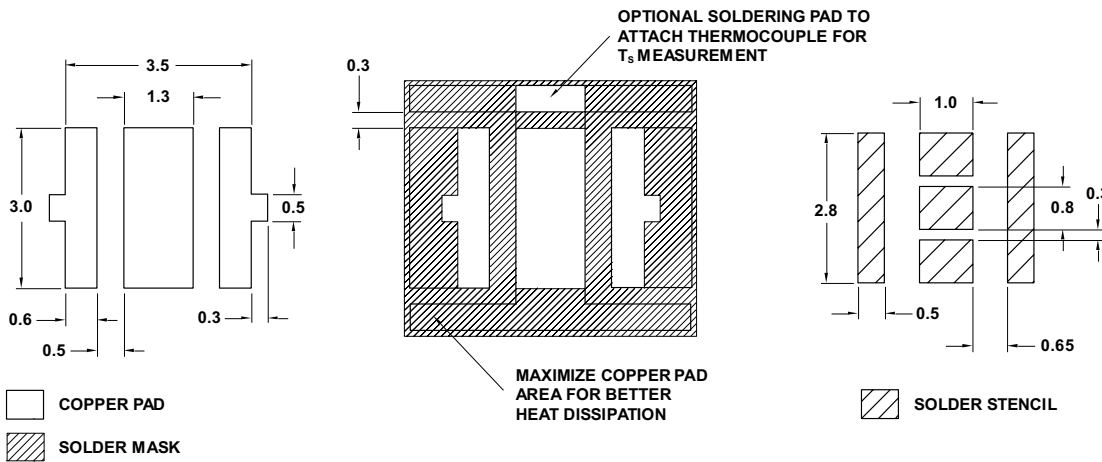
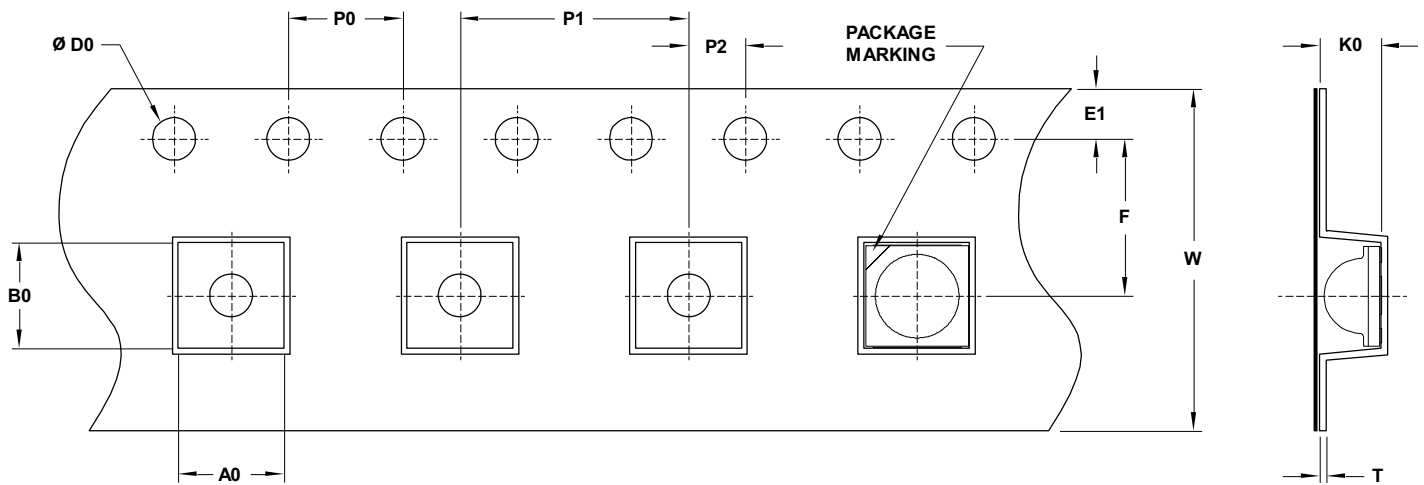

Figure 29: Carrier Tape Dimensions



F	P0	P1	P2	D0	E1	W
5.50 ± 0.05	4.00 ± 0.10	8.00 ± 0.10	2.00 ± 0.05	1.50 ± 0.1	1.75 ± 0.10	12.00 ± 0.20

Part Number	T	A0	B0	K0
ASM6-SxDx	0.28 ± 0.05	3.75 ± 0.10	3.75 ± 0.10	2.20 ± 0.10
ASM6-Sx9x	0.28 ± 0.05	3.75 ± 0.10	3.75 ± 0.10	2.65 ± 0.10

NOTE: All dimensions are in millimeters (mm).

Figure 30: Reel Dimensions

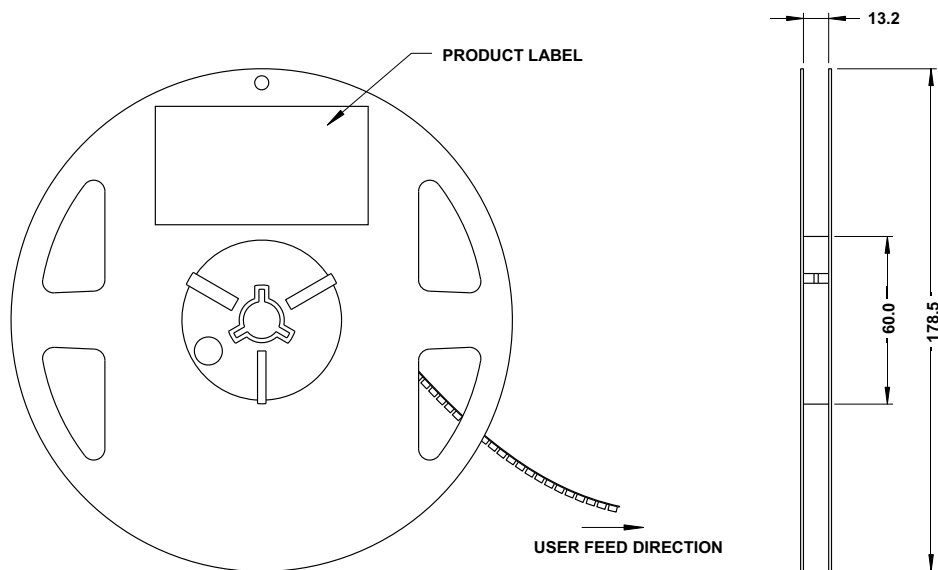

NOTE: All dimensions are in millimeters (mm).

Precautionary Notes

Reflow Soldering

- Do not perform reflow soldering more than twice. Observe necessary precautions of handling moisture-sensitive devices as stated in the following section.
- Do not apply any pressure or force on the LED during reflow and after reflow when the LED is still hot.

Figure 31: Recommended Lead-Free Reflow Soldering Profile

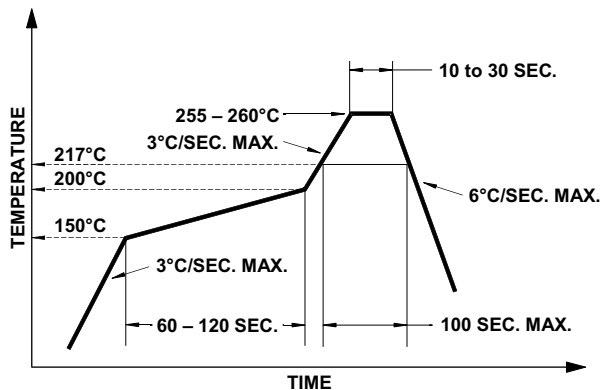

Handling Precautions

The encapsulation material of the LED is made of silicone for better product reliability. Compared to epoxy encapsulant, which is hard and brittle, silicone is softer and flexible. Observe special handling precautions during assembly of silicone encapsulated LED products. Failure to comply might lead to damage and premature failure of the LED. Refer to Broadcom Application Note AN5288, *Silicone Encapsulation for LED: Advantages and Handling Precautions*, for additional information.

- Do not poke sharp objects into the silicone encapsulant. Sharp objects, such as tweezers or syringes, might apply excessive force or even pierce through the silicone and induce failures to the LED die or wire bond.
- Do not touch the silicone encapsulant. Uncontrolled force acting on the silicone encapsulant might result in excessive stress on the wire bond. Hold the LED only by the body.
- Do not stack assembled PCBs together. Use an appropriate rack to hold the PCBs.

- The surface of silicone material attracts dust and dirt easier than epoxy due to its surface tackiness. To remove foreign particles on the surface of silicone, use a cotton bud with isopropyl alcohol (IPA). During cleaning, rub the surface gently without putting too much pressure on the silicone. Ultrasonic cleaning is not recommended.
- For automated pick and place, Broadcom has tested a nozzle size with OD 3.7 mm and ID 3.0 mm to work with this LED. However, due to the possibility of variations in other parameters, such as pick and place, machine maker/model, and other settings of the machine, verify that the selected nozzle will not cause damage to the LED.

Application Precautions

- The drive current of the LED must not exceed the maximum allowable limit across temperature as stated in the data sheet. Constant current driving is recommended to ensure consistent performance.
- Circuit design must cater to the whole range of forward voltage (V_F) of the LEDs to ensure the intended drive current can always be achieved.
- The LED exhibits slightly different characteristics at different drive currents, which can result in a larger variation of performance (such as intensity, wavelength, and forward voltage). Set the application current as close as possible to the test current to minimize these variations.
- Do not use the LED in the vicinity of material with sulfur content or in environments of high gaseous sulfur compounds and corrosive elements. Examples of material that might contain sulfur are rubber gaskets, room-temperature vulcanizing (RTV) silicone rubber, rubber gloves, and so on. Prolonged exposure to such environments can affect the optical characteristics and product life.
- Avoid rapid changes in ambient temperature, especially in high-humidity environments, because they cause condensation on the LED.
- If the LED is intended to be used in a harsh or an outdoor environment, protect the LED against damages caused by rain water, water, dust, oil, corrosive gases, external mechanical stresses, and so on.

Thermal Management

The optical, electrical, and reliability characteristics of the LED are affected by temperature. Keep the junction temperature (T_J) of the LED below the allowable limit at all times. T_J can be calculated as follows:

$$T_J = T_A + R_{\theta J-A} \times I_F \times V_{Fmax}$$

where:

T_A = Ambient temperature ($^{\circ}\text{C}$)

$R_{\theta J-A}$ = Thermal resistance from LED junction to ambient ($^{\circ}\text{C}/\text{W}$)

I_F = Forward current (A)

V_{Fmax} = Maximum forward voltage (V)

The complication of using this formula lies in T_A and $R_{\theta J-A}$. Actual T_A is sometimes subjective and hard to determine. $R_{\theta J-A}$ varies from system to system depending on design and is usually not known.

Another way of calculating T_J is by using the solder point temperature, T_S as follows:

$$T_J = T_S + R_{\theta J-S} \times I_F \times V_{Fmax}$$

where:

T_S = LED solder point temperature as shown in the following figure ($^{\circ}\text{C}$)

$R_{\theta J-S}$ = Thermal resistance from junction to solder point ($^{\circ}\text{C}/\text{W}$)

I_F = Forward current (A)

V_{Fmax} = Maximum forward voltage (V)

Figure 32: Solder Point Temperature on PCB

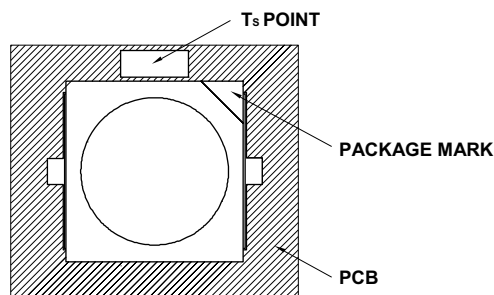

T_S can be easily measured by mounting a thermocouple on the soldering joint as shown in preceding figure, while $R_{\theta J-S}$ is provided in the data sheet. Verify the T_S of the LED in the final product to ensure that the LEDs are operating within all maximum ratings stated in the data sheet.

Eye Safety Precautions

LEDs can pose optical hazards when in operation. Do not look directly at operating LEDs because it might be harmful to the eyes. For safety reasons, use appropriate shielding or personal protective equipment.

Disclaimer

Broadcom's products and software are not specifically designed, manufactured, or authorized for sale as parts, components, or assemblies for the planning, construction, maintenance, or direct operation of a nuclear facility or for use in medical devices or applications. The customer is solely responsible, and waives all rights to make claims against Broadcom or its suppliers, for all loss, damage, expense, or liability in connection with such use.

Copyright © 2020–2022 Broadcom. All Rights Reserved. The term “Broadcom” refers to Broadcom Inc. and/or its subsidiaries. For more information, go to www.broadcom.com. All trademarks, trade names, service marks, and logos referenced herein belong to their respective companies.

Broadcom reserves the right to make changes without further notice to any products or data herein to improve reliability, function, or design. Information furnished by Broadcom is believed to be accurate and reliable. However, Broadcom does not assume any liability arising out of the application or use of this information, nor the application or use of any product or circuit described herein, neither does it convey any license under its patent rights nor the rights of others.

