

THIS COPY IS PROVIDED ON A RESTRICTED BASIS AND IS NOT TO BE USED IN ANY WAY DETRIMENTAL TO THE INTERESTS OF PANDUIT CORP.

PANDUIT P/N	WEIGHT
SPS688-C	.743 LB/100 PCS (337 g/100 PCS)

NOTES:

1. MATERIAL: HOUSING, LOAD BAR, DIVIDER, STRAIN COLLAR - THERMOPLASTIC UL94V-0 RATED; STRAIN RELIEF BOOT - TPE-UL94-HB RATED; CONTACT TERMINAL - PHOSPHOR BRONZE ELECTRO-POLISHED AND PLATED WITH .000050" MIN. GOLD IN MATING AREA, GOLD FLASH OVER REMAINDER, .000100" MIN. NICKEL UNDERPLATE; SHIELD - CARTRIDGE BRASS WITH NICKEL PLATING.
2. PLUG ACCEPTS 4 PAIR CABLE .225-.250" DIA. WITH 24-26 AWG CONDUCTOR WITH A MAXIMUM INSULATOR DIAMETER OF .040".
3. MEETS DIMENSIONAL REQUIREMENTS OF FCC PART 68 AND IEC 60603-7. ALL DIMENSIONS MAXIMUM UNLESS OTHERWISE SPECIFIED.
4. TERMINATED CONTACT HEIGHT DIMENSION: .237±.005".
5. PACKAGE QUANTITY= 100
6. RATED FOR 2500 MATING CYCLES.
7. UL AND CSA LISTED.

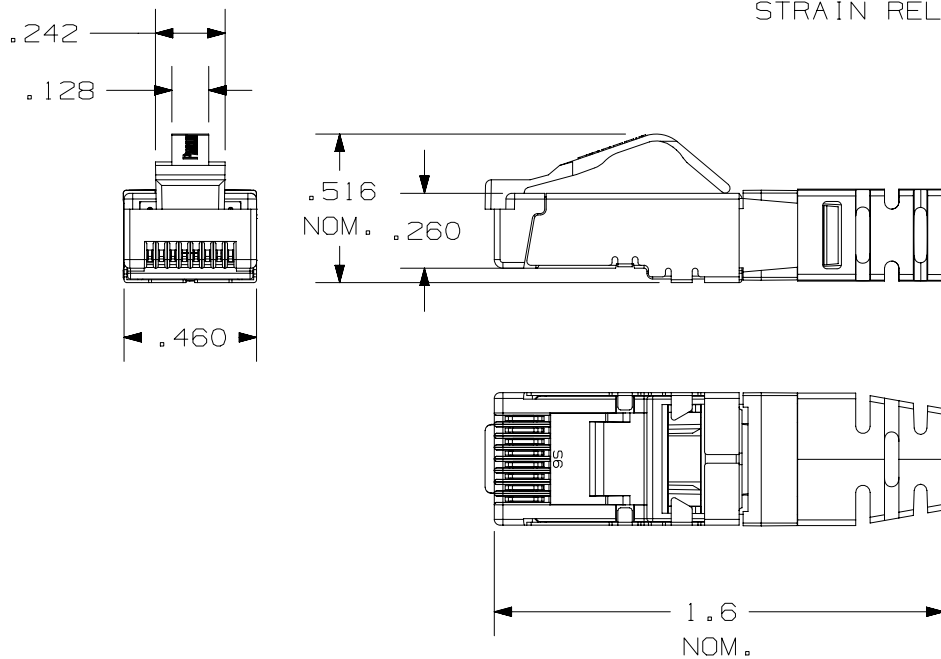

STRAIN RELIEF BOOT (BLACK)

STRAIN COLLAR

DIVIDER

LOAD BAR

SHIELDED PLUG HOUSING W/CONTACTS

PART NUMBER		SPS688-C	
TITLE		CATEGORY 6/6A SHIELDED MODULAR PLUG	
		CUSTOMER DRAWING	
ITEM REVISION NAME		M02085BA/28	
DATASET FILE NAME		M02085BA_DC02/28A	
UNLESS OTHERWISE SPECIFIED, DIMENSIONAL TOLERANCES ARE: IN (mm)		MATERIAL:	
.x ± .xx ± .03 (.8)		SEE NOTES	
.xxx ± .010 (.3)		DRAWING NUMBER:	
ANGLES ±		02085-02	
THIRD ANGLE PROJECTION		SHT 1 OF 1	
DRAWN BY	DATE	CHK	SCALE
MDJR	11-30-04	PBD	NONE
REV	DATE	BY	CHK
APR	DESCRIPTION	ECN	SIZE
			A

REV	DATE	BY	CHK	APR	DESCRIPTION	ECN
5	7/24/17	BJN	NAGL	TMBA	UPDATED	02085-02
4	9/26/14	MDJR	REFR	TMBA	UPDATED	02085-02
3	3/21/14	JSP	REFR	EJH	REVISED AND REDRAWN, PREVIOUS REVISIONS HAVE BEEN OMITTED.	02085-02

D101000DA/14