

Bestückungsplan / contact layout

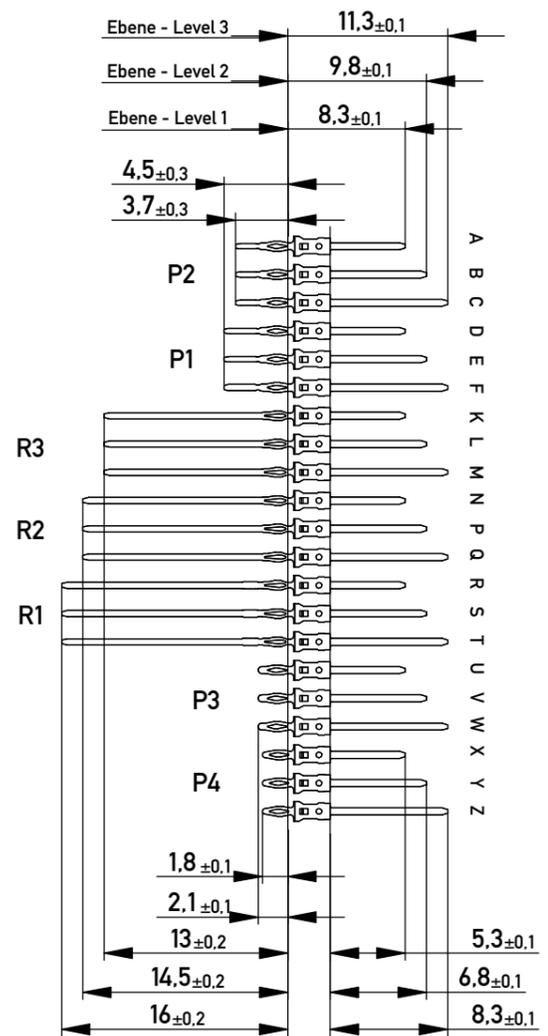

Lochbild für Leiterplatte (Bestückungsseite)

board hole pattern (component mounting side)

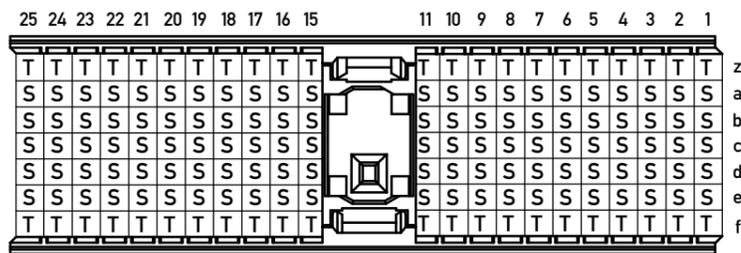
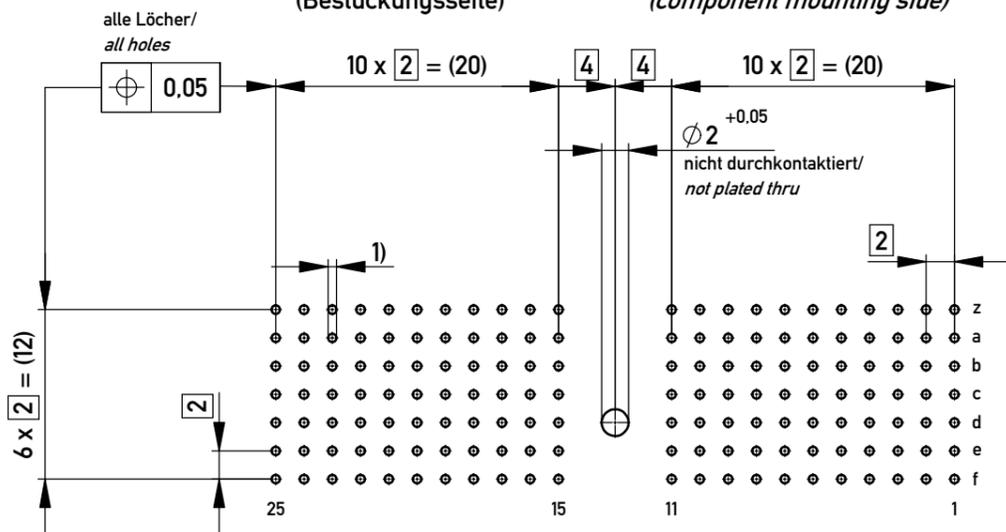

- 1) $\phi 0,6 \pm 0,05$ Durchmesser des metallisierten Loches
 $\phi 0,6 \pm 0,05$ Diameter of finished plated-through hole

Schichtaufbau im metallisierten Loch siehe Zeichnung 164062 Nr.1
Metal plating of plated-through hole according to 164062 No.1

Fehlende Maße und Angaben nach IEC 61076-4-101
Missing information and dimensions per IEC 61076-4-101

Information:
R1 Level 2, 3
siehe Bestückungsplan / see contact layout
Anforderungsstufe 2 / class 2

All rights reserved.
Only for Information.
To ensure that this is the latest version of this drawing, please contact one of the ERNI companies before using.

Index

Date

Tolerances

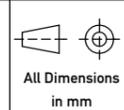

Scale 2:1

Subject to modification without prior notice.
Drawing will not be updated.

Designation

ERmet Messerleiste A
ERmet Male Wide Type A

www.ERNI.com

103975

I
A3

Class ERMA

Copyright by ERNI Production GmbH & Co. KG
Proprietary notice pursuant to ISO 16016 to be observed.