

## Recommended Applications

PCIe Gen1-2-3 Synthesizer for Common and SRNS-clocked systems

## General Description

The IDT5V41315 is a PCIe Gen1-2-3 clock synthesizer suitable for use in both Common-Clocked and Separate Reference clock with No Spread (SRNS) timing architectures. The IDT5V41315 uses a 25MHz input to generate 4 different output frequencies. The output frequency is selectable via select pins.

## Output Features

- 2 - 0.7V current mode differential HCSL output pairs

## Block Diagram

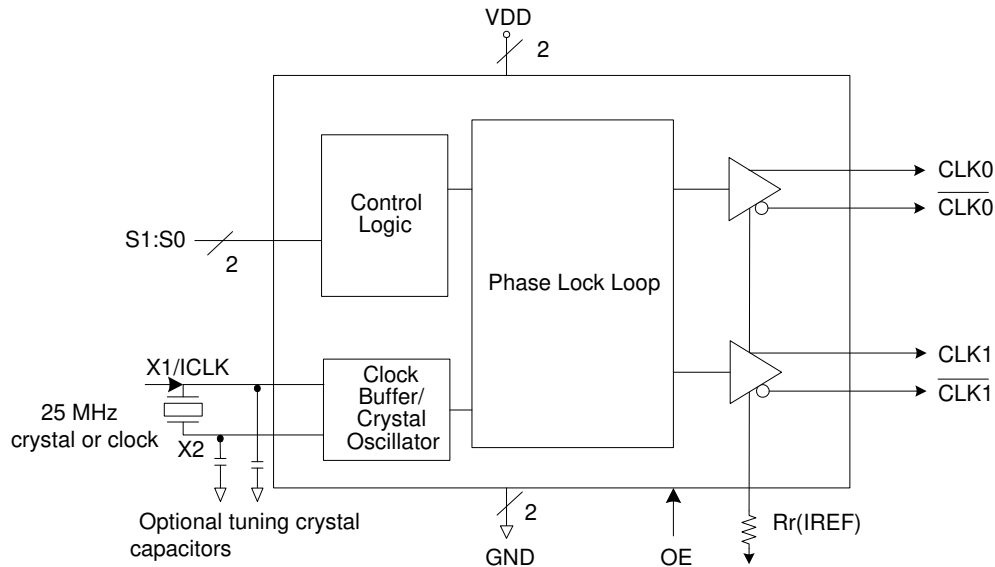

## Features/Benefits

- 16-pin TSSOP or VQFPN package; small board footprint
- Outputs can be terminated to LVDS; can drive a wider variety of devices
- OE control pin; greater system power management
- Industrial temperature range available; supports demanding embedded applications

## Key Specifications

- Cycle-to-cycle jitter: 80ps
- Output-to-output skew: <50 ps
- PCIe Gen2 phase jitter: <3.0ps RMS (Common Clock)
- PCIe Gen3 phase jitter: <1.0ps RMS (Common Clock)
- Low Phase Noise: 12KHz to 20MHz <6ps RMS

## Pin Assignments

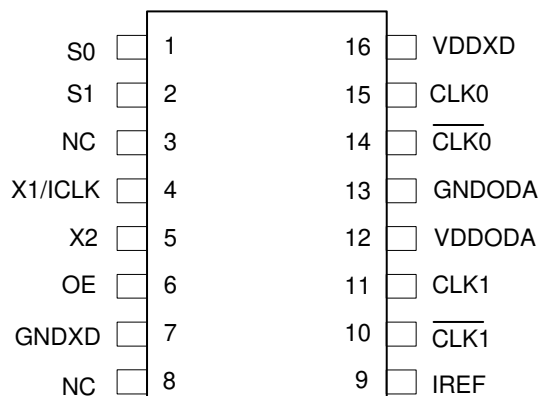

16-pin (173 mil) TSSOP

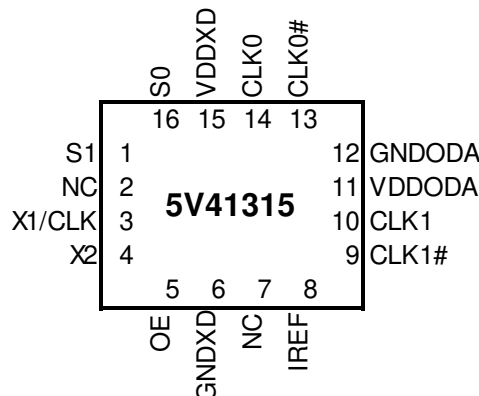

16-pin VFQFPN

## Output Select Table 1 (MHz)

S1	S0	CLK(1:0), CLK(1:0)
0	0	25M
0	1	100M
1	0	125M
1	1	200M

## Pin Descriptions

VFQFPN Pin Number	TSSOP Pin Number	Pin Name	Pin Type	Pin Description
16	1	S0	Input	Select pin 0. See Table1. Internal pull-up resistor.
1	2	S1	Input	Select pin 1. See Table 1. Internal pull-up resistor.
2	3	NC	--	No connect.
3	4	X1/ICLK	Input	Crystal or clock input. Connect to a 25 MHz crystal or single ended clock.
4	5	X2	Output	Crystal connection. Leave unconnected for clock input.
5	6	OE	Input	Output enable. Tri-states outputs and device is not shut down. Internal pull-up resistor.
6	7	GNDXD	Power	Connect to ground.
7	8	NC	--	No connect.
8	9	IREF	Output	Precision resistor attached to this pin is connected to the internal current reference, typically 475 ohm.
9	10	CLK1	Output	HCSL complementary clock output 1.
10	11	CLK1	Output	HCSL true clock output 1.
11	12	VDDODA	Power	Connect to voltage supply +3.3 V for output driver and analog circuits
12	13	GNDODA	Power	Connect to ground.
13	14	CLK0	Output	HCSL complementary clock output 0.
14	15	CLK0	Output	HCSL true clock output 0.
15	16	VDDXD	Power	Connect to voltage supply +3.3 V for crystal oscillator and digital circuit.

## Absolute Maximum Ratings

Stresses above the ratings listed below can cause permanent damage to the IDT5V41315. These ratings are stress ratings only. Functional operation of the device at these or any other conditions above those indicated in the operational sections of the specifications is not implied. Exposure to absolute maximum rating conditions for extended periods can affect product reliability. Electrical parameters are guaranteed only over the recommended operating temperature range.

Item	Rating
Supply Voltage, VDDXD, VDDODA	4.6 V
All Inputs and Outputs	-0.5 V to VDD+0.5 V
Storage Temperature	-65 to +150°C
Junction Temperature	125°C
Soldering Temperature	260°C
ESD Protection (Input)	2000 V min. (HBM)

## DC Electrical Characteristics

Unless stated otherwise, VDD = 3.3 V ±5%, T<sub>A</sub> = T<sub>AMBIENT</sub>

Parameter	Symbol	Conditions	Min.	Typ.	Max.	Units
Supply Voltage	V		3.135	3.3	3.465	V
Ambient Operating Temperature	T <sub>AMBIENT</sub>	Industrial Temperature range	-40	+25	+85	°C
Input High Voltage <sup>1</sup>	V <sub>IH</sub>	S0, S1, OE, ICLK	2.2		VDD +0.3	V
Input Low Voltage <sup>1</sup>	V <sub>IL</sub>	S0, S1, OE, ICLK	VSS-0.3		0.8	V
Input Leakage Current <sup>2</sup>	I <sub>IL</sub>	0 < V <sub>in</sub> < VDD	-5		5	μA
Operating Supply Current @ 100 MHz	I <sub>DD</sub>	R <sub>S</sub> =33Ω, R <sub>P</sub> =50Ω, C <sub>L</sub> =2 pF		63	85	mA
	I <sub>DDOE</sub>	OE =Low		42	50	mA
Input Capacitance	C <sub>IN</sub>	Input pin capacitance			7	pF
Output Capacitance	C <sub>OUT</sub>	Output pin capacitance			6	pF
X1, X2 Capacitance	C <sub>INX</sub>				5	pF
Pin Inductance	L <sub>PIN</sub>				5	nH
Output Impedance	Z <sub>O</sub>	CLK outputs	3.0			kΩ
Pull-up Resistor	R <sub>PU</sub>	S0, S1, OE		100		kΩ

1. Single edge is monotonic when transitioning through region.
2. Inputs with pull-ups/-downs are not included.

## AC Electrical Characteristics - CLK0/CLK1, $\overline{\text{CLK0/CLK1}}$

Unless stated otherwise, VDD=3.3 V  $\pm$ 5%, T<sub>A</sub> = T<sub>AMBIENT</sub>

Parameter	Symbol	Conditions	Min.	Typ.	Max.	Units
Input Frequency				25		MHz
Output Frequency		HCSL termination	25		200	MHz
		LVDS termination	25		100	MHz
Output High Voltage <sup>1,2</sup>	V <sub>OH</sub>	HCSL			850	mV
Output Low Voltage <sup>1,2</sup>	V <sub>OL</sub>	HCSL	-150			mV
Crossing Point Voltage <sup>1,2</sup>		Absolute	250		550	mV
Crossing Point Voltage <sup>1,2,4</sup>		Variation over all edges			140	mV
Jitter, Cycle-to-Cycle <sup>1,3</sup>					80	ps
Frequency Synthesis Error		All outputs		0		ppm
Rise Time <sup>1,3</sup>	t <sub>OR</sub>	$\pm$ 150mV	1		4	V/ns
Fall Time <sup>1,3</sup>	t <sub>OF</sub>	$\pm$ 150mV	1		4	V/ns
Rise/Fall Time Variation <sup>1,2</sup>					125	ps
Output to Output Skew					50	ps
Duty Cycle <sup>1,3</sup>			45		55	%
Output Enable Time <sup>5</sup>		All outputs		50	100	ns
Output Disable Time <sup>5</sup>		All outputs		50	100	ns
Stabilization Time	t <sub>STABLE</sub>	From power-up VDD=3.3 V			1.8	ms

Note 1: Test setup is R<sub>S</sub>=33 $\Omega$ , R<sub>P</sub>=50 $\Omega$  with C<sub>L</sub>=2 pF, R<sub>r</sub> = 475 $\Omega$  (1%).

Note 2: Measurement taken from a single-ended waveform.

Note 3: Measurement taken from a differential waveform.

Note 4: Measured at the crossing point where instantaneous voltages of both CLK and  $\overline{\text{CLK}}$  are equal.

Note 5: CLK pins are tri-stated when OE is low asserted. CLK is driven differential when OE is high.

## Electrical Characteristics - Differential Phase Jitter Parameters

T<sub>A</sub> = T<sub>AMBIENT</sub>, Supply Voltage VDD = 3.3 V  $\pm$ 5%

PARAMETER	Symbol	Conditions	Min	Typ	Max	Units	Notes
Jitter, Phase	t <sub>jphaseG1</sub>	PCIe Gen 1		32	86	ps (p-p)	1,2,3
	t <sub>jphaseG2Lo</sub>	PCIe Gen 2 10kHz < f < 1.5MHz		0.7	3	ps (RMS)	1,2,3
	t <sub>jphaseG2High</sub>	PCIe Gen 2 1.5MHz < f < Nyquist (50MHz)		2.3	3.1	ps (RMS)	1,2,3
	t <sub>jphaseG3</sub>	PCIe Gen 3		0.6	1	ps (RMS)	1,2,3
	t <sub>jphase12K20M</sub>	12kHz-20MHz			N/A	ps (RMS)	1,2,3

<sup>1</sup>Guaranteed by design and characterization, not 100% tested in production.

<sup>2</sup>See <http://www.pcisig.com> for complete specs

<sup>3</sup>Applies to 100MHz

## Applications Information

### External Components

A minimum number of external components are required for proper operation.

### Decoupling Capacitors

Decoupling capacitors of 0.01  $\mu\text{F}$  should be connected between each VDD pin and the ground plane, as close to the VDD pin as possible. Do not share ground vias between components. Route power from power source through the capacitor pad and then into ICS pin.

### Crystal

A 25 MHz fundamental mode parallel resonant crystal should be used. This crystal must have less than 300 ppm of error across temperature in order for the IDT5V41315 to meet PCI Express specifications.

### Crystal Capacitors

Crystal capacitors are connected from pins X1 to ground and X2 to ground to optimize the accuracy of the output frequency.

$C_L$  = Crystal's load capacitance in pF

Crystal Capacitors (pF) =  $(C_L - 8) * 2$

For example, for a crystal with a 16 pF load cap, each external crystal cap would be 16 pF.  $(16 - 8) * 2 = 16$ .

Current Source (Iref) Reference Resistor -  $R_R$

If board target trace impedance (Z) is 50 $\Omega$ , then  $R_R = 475\Omega$  (1%), providing IREF of 2.32 mA. The output current ( $I_{OH}$ ) is equal to 6\*IREF.

### Output Termination

The PCI-Express differential clock outputs of the IDT5V41315 are open source drivers and require an external series resistor and a resistor to ground. These resistor values and their allowable locations are shown in detail in the **PCI-Express Layout Guidelines** section.

The IDT5V41315 can also be configured for LVDS compatible voltage levels. See the **LVDS Compatible Layout Guidelines** section.

## Output Structures

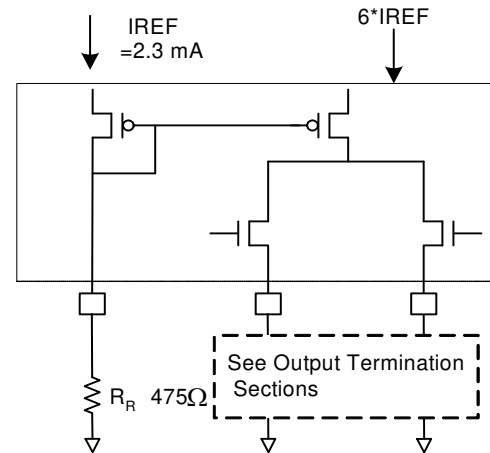

### General PCB Layout Recommendations

For optimum device performance and lowest output phase noise, the following guidelines should be observed.

1. Each 0.01 $\mu\text{F}$  decoupling capacitor should be mounted on the component side of the board as close to the VDD pin as possible.
2. No vias should be used between decoupling capacitor and VDD pin.
3. The PCB trace to VDD pin should be kept as short as possible, as should the PCB trace to the ground via. Distance of the ferrite bead and bulk decoupling from the device is less critical.
4. An optimum layout is one with all components on the same side of the board, minimizing vias through other signal layers (any ferrite beads and bulk decoupling capacitors can be mounted on the back). Other signal traces should be routed away from the IDT5V41315. This includes signal traces just underneath the device, or on layers adjacent to the ground plane layer used by the device.

## Layout Guidelines

SRC Reference Clock			
Common Recommendations for Differential Routing	Dimension or Value	Unit	Figure
L1 length, route as non-coupled 50ohm trace	0.5 max	inch	1
L2 length, route as non-coupled 50ohm trace	0.2 max	inch	1
L3 length, route as non-coupled 50ohm trace	0.2 max	inch	1
Rs	33	ohm	1
Rt	49.9	ohm	1

Down Device Differential Routing			
L4 length, route as coupled microstrip 100ohm differential trace	2 min to 16 max	inch	1
L4 length, route as coupled stripline 100ohm differential trace	1.8 min to 14.4 max	inch	1

Differential Routing to PCI Express Connector			
L4 length, route as coupled microstrip 100ohm differential trace	0.25 to 14 max	inch	2
L4 length, route as coupled stripline 100ohm differential trace	0.225 min to 12.6 max	inch	2

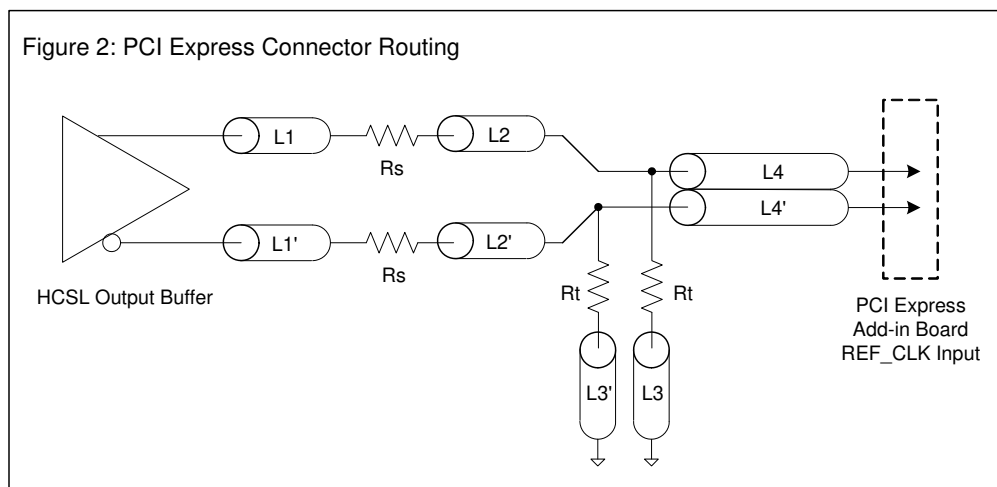
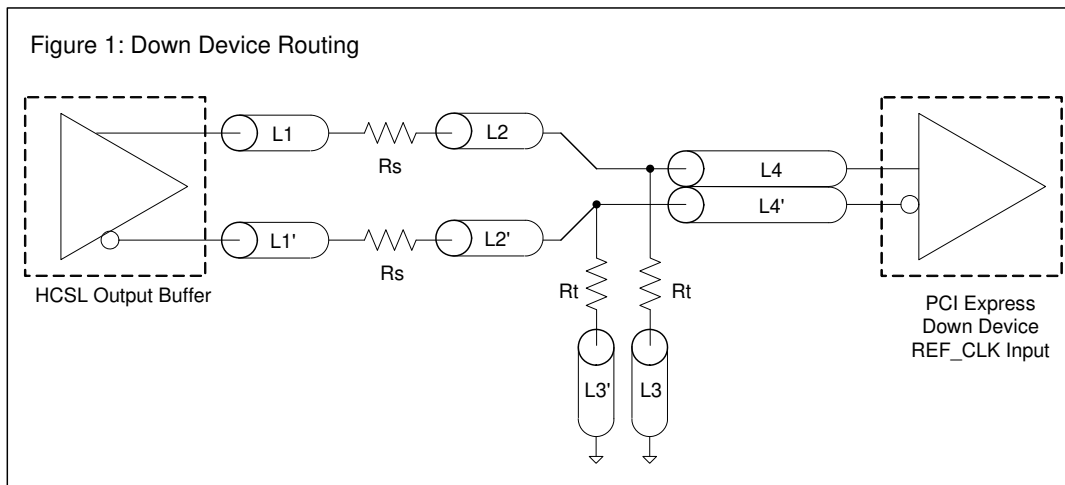

**Alternative Termination for LVDS and other Common Differential Signals (figure 3)**

Vdiff	Vp-p	Vcm	R1	R2	R3	R4	Note
0.45v	0.22v	1.08	33	150	100	100	
0.58	0.28	0.6	33	78.7	137	100	
0.80	0.40	0.6	33	78.7	none	100	ICS874003i-02 input compatible
0.60	0.3	1.2	33	174	140	100	Standard LVDS

R1a = R1b = R1

R2a = R2b = R2

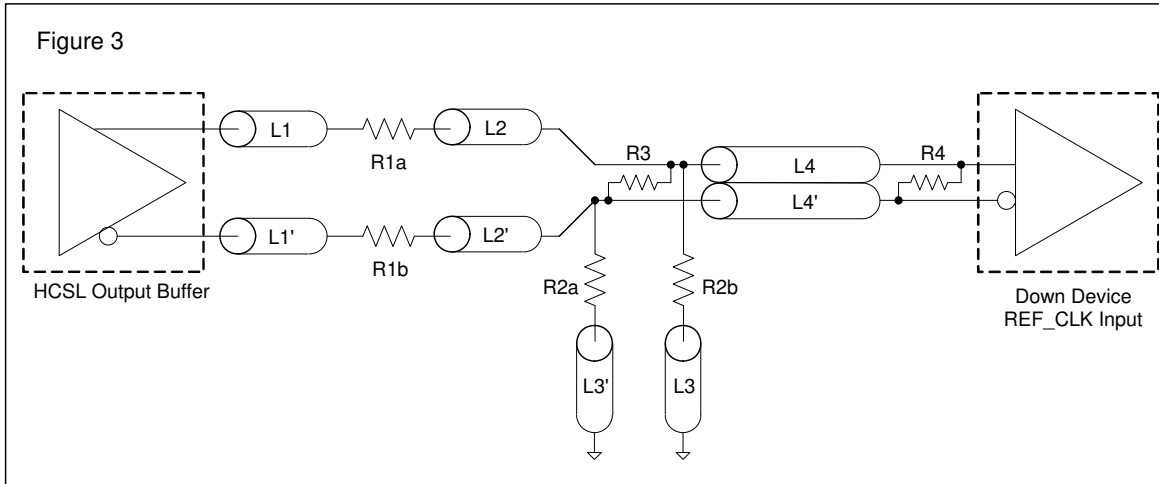

**Cable Connected AC Coupled Application (figure 4)**

Component	Value	Note
R5a, R5b	8.2K 5%	
R6a, R6b	1K 5%	
Cc	0.1 $\mu$ F	
Vcm	0.350 volts	

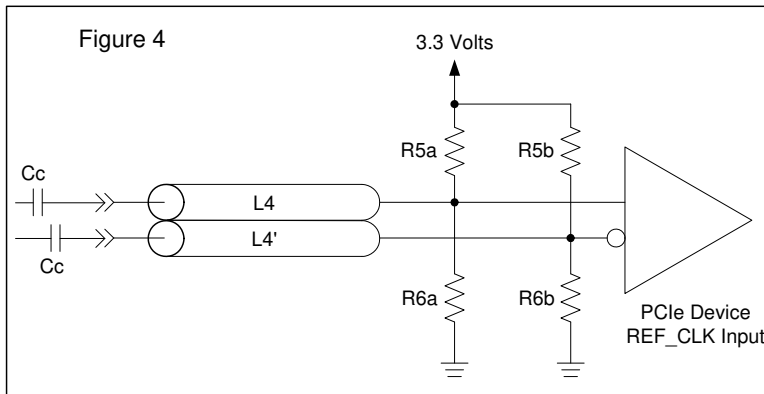

### Typical PCI-Express (HCSL) Waveform

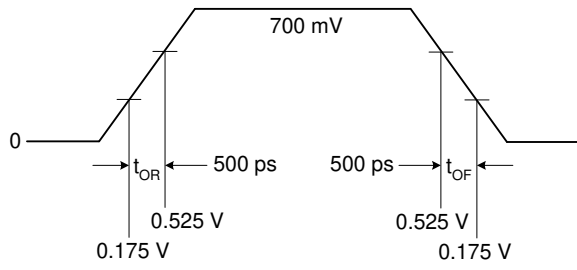

### Typical LVDS Waveform

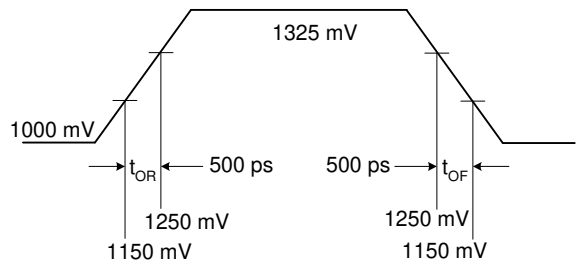



## Thermal Characteristics (16-TSSOP)

Parameter	Symbol	Conditions	Min.	Typ.	Max.	Units
Thermal Resistance Junction to Ambient	$\theta_{JA}$	Still air		78		°C/W
	$\theta_{JA}$	1 m/s air flow		70		°C/W
	$\theta_{JA}$	3 m/s air flow		68		°C/W
Thermal Resistance Junction to Case	$\theta_{JC}$			37		°C/W

## Thermal Characteristics (16-VFQFPN)

Parameter	Symbol	Conditions	Min.	Typ.	Max.	Units
Thermal Resistance Junction to Ambient	$\theta_{JA}$	Still air		63.2		°C/W
	$\theta_{JA}$	1 m/s air flow		55.9		°C/W
	$\theta_{JA}$	3 m/s air flow		51.4		°C/W
Thermal Resistance Junction to Case	$\theta_{JC}$			65.8		°C/W

## Marking Diagrams

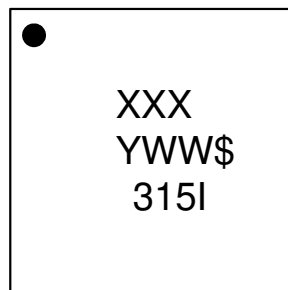
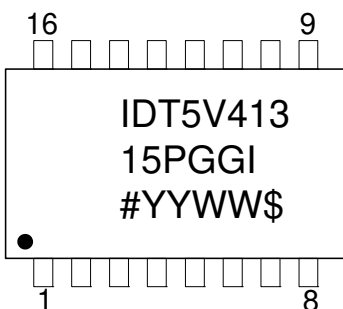

### Notes:

1. "XXX" denotes lot number.
2. "#" denotes die revision.
3. "YYWW" or "YWW" denotes date code
4. "\$" denotes assembly location.
5. "G" after the two-letter package code designates RoHS compliant package.
6. "I" at the end of part number indicates industrial temperature range.
7. Bottom marking: country of origin if not USA (TSSOP package only).

Package Outline and Dimensions (3 x 3 mm 16-VFQFPN)

REVISIONS			
REV	DESCRIPTION	DATE	APPROVED
00	INITIAL RELEASE	10/15/08	RC
01	COMBINE POD & LAND PATTERN	9/17/13	KS

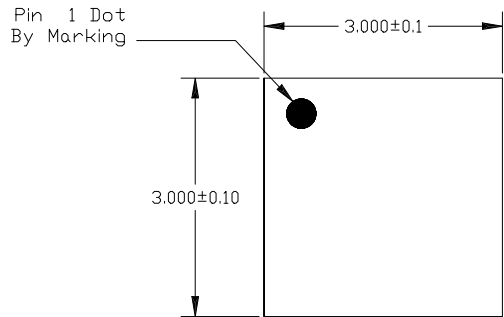

TOP VIEW

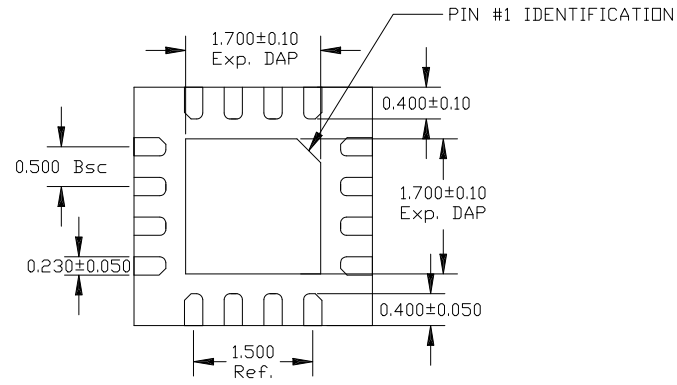

BOTTOM VIEW

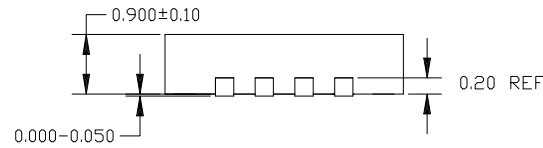

TOP VIEW

16LD QFN 3X3 (0.5MM PITCH)

TOLERANCES UNLESS SPECIFIED		 6024 Silver Creek Valley Road San Jose, CA 95138 PHONE: (408) 284-8200 FAX: (408) 284-8591	
DECIMAL	ANGULAR	www.IDT.com	
XX±	±	TITLE NL/NLG16 PACKAGE OUTLINE 3.0 x 3.0 mm BODY 0.5 mm PITCH QFN	
XXX±		APPROVALS	DATE
XXXX±		DRAWN	10/15/08
		CHECKED	
		SIZE	DRAWING No.
		C	PSC-4169
			REV
			01
DO NOT SCALE DRAWING		SHEET 1 OF 2	

Package Outline and Dimensions (3 x 3 mm 16-VFQFPN), cont.

REVISIONS			
REV	DESCRIPTION	DATE	APPROVED
00	INITIAL RELEASE	10/15/08	RC
01	COMBINE POD & LAND PATTERN	9/17/13	KS

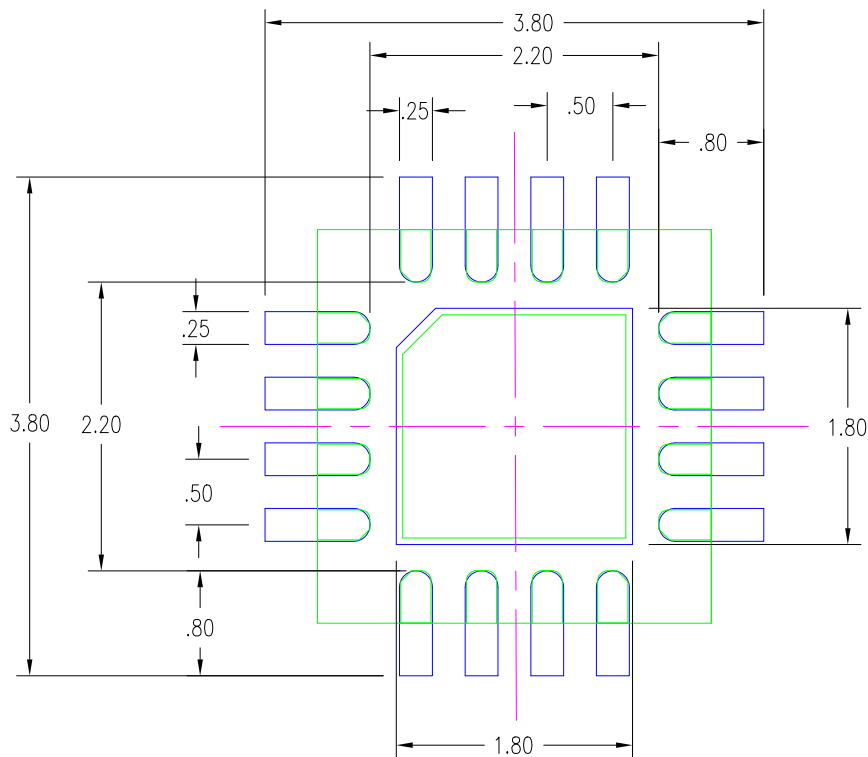

NOTES:

1. ALL DIMENSION ARE IN mm. ANGLES IN DEGREES.
2. TOP DOWN VIEW, AS VIEWED ON PCB.
3. COMPONENT OUTLINE SHOW FOR REFERENCE IN GREEN.
4. LAND PATTERN IN BLUE. NSMD PATTERN ASSUMED.
5. LAND PATTERN RECOMMENDATION PER IPC-7351B GENERIC REQUIREMENT FOR SURFACE MOUNT DESIGN AND LAND PATTERN.

TOLERANCES UNLESS SPECIFIED		 6024 Silver Creek Valley Road San Jose, CA 95138 PHONE: (408) 284-8200 FAX: (408) 284-8591 <a href="http://www.IDT.com">www.IDT.com</a>		
DECIMAL	ANGULAR			
XX±	±			
XXX±				
XXXX±				
APPROVALS	DATE	TITLE		
DRAWN <i>RC</i>	10/15/08	NL/NLG16 PACKAGE OUTLINE 3.0 x 3.0 mm BODY 0.5 mm PITCH QFN		
CHECKED				
		SIZE	DRAWING No.	REV
		C	PSC-4169	01
DO NOT SCALE DRAWING			SHEET 2 OF 2	

Package Outline and Dimensions (16-TSSOP, 4.4 mm body)

DATE CREATED		REVISIONS		
REV	DESCRIPTION	AUTHOR		
02	ADD 14 & 16 LD	T. VU		
03	ADD 8 LD	T. VU		
04	ADDED TOPMARK TO TITLE			
05	ADD "GREEN" PGG NOMENCLATURE	TU VU		
06	ADDED PACKAGE CODE	RAC		
07	ADD TOLERANCE FOR A, A1, E AND b	CK LEE		
08	ADD OPTION T1	R.TANH		

NOTE: REFER TO DCP FOR OFFICIAL RELEASE DATE

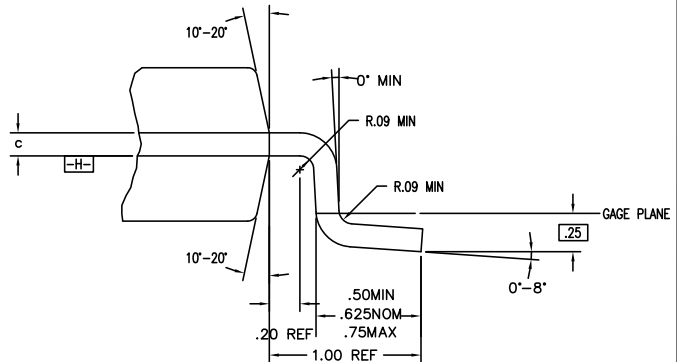
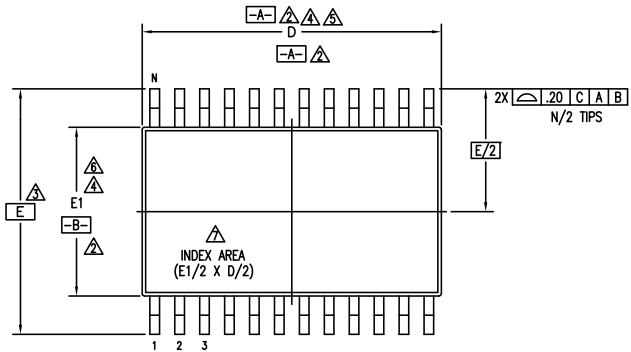

DETAIL B

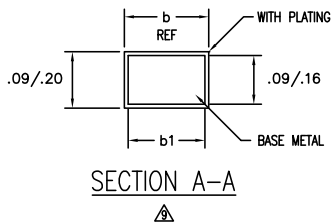
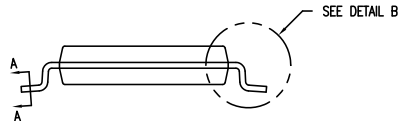
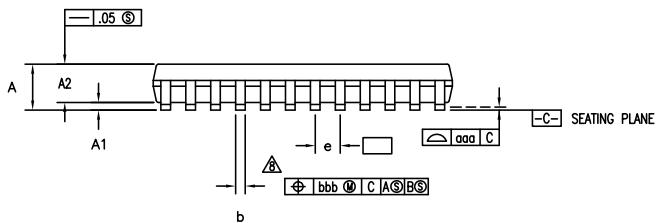

TOLERANCES UNLESS SPECIFIED		<p>2975 Stender Way Santa Clara, CA 95054 PHONE: (408) 727-6116 FAX: (408) 492-8674 www.IDT.com</p>
DECIMAL	ANGULAR	
XX±	±	
XXX±		
		<p>TITLE PC/PGC PACKAGE OUTLINE (PG OR PA TOPMARK CODE) 4.4 mm BODY WIDTH TSSOP .65 mm PITCH</p>
SIZE	DRAWING No.	REV
C	PSC-4056	08
DO NOT SCALE DRAWING		SHEET 1 OF 3

Package Outline and Dimensions (16-TSSOP, 4.4 mm body), cont.

DATE CREATED		REVISIONS		
REV	DESCRIPTION	AUTHOR		
08/25/98	02	ADD 14 & 16 LD	T. VU	
07/10/99	03	ADD 8 LD	T. VU	
5/23/01	04	ADDED TOPMARK TO TITLE		
10/14/04	05	ADD "GREEN" PGG NOMENCLATURE	TU VU	
3/8/13	06	ADDED PACKAGE CODE	RAC	
9/3/14	07	ADD TOLERANCE FOR A, A1, E AND b	CK LEE	
3/10/17	08	ADD OPTION T1	R.TANH	

NOTE: REFER TO DCP FOR OFFICIAL RELEASE DATE

SYMBOL	PG/PGG8				PG/PGG14				PG/PGG16				PG/PGG20				PG/PGG24				PG/PGG28			
	JEDEC VARIATION			NOTE	JEDEC VARIATION			NOTE	JEDEC VARIATION			NOTE	JEDEC VARIATION			NOTE	JEDEC VARIATION			NOTE				
	AA				AB-1				AB				AC				AD				AE			
	MIN	NOM	MAX		MIN	NOM	MAX		MIN	NOM	MAX		MIN	NOM	MAX		MIN	NOM	MAX					
A	.85	1.10	1.20		.85	1.10	1.20		.85	1.10	1.20		.85	1.10	1.20		.85	1.10	1.20					
A1	.05	.10	.15		.05	.10	.15		.05	.10	.15		.05	.10	.15		.05	.10	.15					
A2	.80	1.00	1.05		.80	1.00	1.05		.80	1.00	1.05		.80	1.00	1.05		.80	1.00	1.05					
D	2.90	3.00	3.10	4,5	4.90	5.00	5.10	4,5	4.90	5.00	5.10	4,5	6.40	6.50	6.60	4,5	7.70	7.80	7.90	4,5				
E	6.20	6.40	6.60	3	6.20	6.40	6.60	3	6.20	6.40	6.60	3	6.20	6.40	6.60	3	6.20	6.40	6.60	3				
E1	4.30	4.40	4.50	4,6	4.30	4.40	4.50	4,6	4.30	4.40	4.50	4,6	4.30	4.40	4.50	4,6	4.30	4.40	4.50	4,6				
e	.65 BSC				.65 BSC				.65 BSC				.65 BSC				.65 BSC							
b	.19	.25	.30		.19	.25	.30		.19	.25	.30		.19	.25	.30		.19	.25	.30					
b1	.19	.22	.25		.19	.22	.25		.19	.22	.25		.19	.22	.25		.19	.22	.25					
aaa	-	-	.10		-	-	.10		-	-	.10		-	-	.10		-	-	.10					
bbb	-	-	.10		-	-	.10		-	-	.10		-	-	.10		-	-	.10					
N	8				14				16				20				24				28			

NOTES:

- ALL DIMENSIONING AND TOLERANCING CONFORM TO ASME Y14.5M-1994
- DATUMS **-A-** AND **-B-** TO BE DETERMINED AT DATUM PLANE **-H-**
- DIMENSION E TO BE DETERMINED AT SEATING PLANE **-C-**
- DIMENSIONS D AND E1 ARE TO BE DETERMINED AT DATUM PLANE **-H-**
- DIMENSION D DOES NOT INCLUDE MOLD FLASH, PROTRUSIONS OR GATE BURRS. MOLD FLASH, PROTRUSIONS OR GATE BURRS SHALL NOT EXCEED .15 mm PER SIDE
- DIMENSION E1 DOES NOT INCLUDE INTERLEAD FLASH OR PROTRUSIONS. INTERLEAD FLASH OR PROTRUSIONS SHALL NOT EXCEED .25 mm PER SIDE
- DETAIL OF PIN 1 IDENTIFIER IS OPTIONAL BUT MUST BE LOCATED WITHIN THE ZONE INDICATED
- LEAD WIDTH DIMENSION DOES NOT INCLUDE DAMBAR PROTRUSION. ALLOWABLE DAMBAR PROTRUSION IS .08 mm IN EXCESS OF THE LEAD WIDTH DIMENSION AT MAXIMUM MATERIAL CONDITION. DAMBAR CANNOT BE LOCATED ON THE LOWER RADIUS OR THE FOOT
- THESE DIMENSIONS APPLY TO THE FLAT SECTION OF THE LEAD BETWEEN .10 AND .25 mm FROM THE LEAD TIP
- ALL DIMENSIONS ARE IN MILLIMETERS
- THIS OUTLINE CONFORMS TO JEDEC PUBLICATION 95 REGISTRATION MO-153, VARIATION AA, AB-1, AB, AC, AD & AE

OPTION T1				
PGG14T1				
SYMBOL	JEDEC VARIATION			NOTE
	AB-1			
	MIN	NOM	MAX	
A	.90	1.10	1.20	
A1	.05	.10	.15	
A2	.80	1.00	1.05	
D	4.90	5.00	5.10	4,5
E	6.20	6.40	6.60	3
E1	4.30	4.40	4.50	4,6
e	.65 BSC			
b	.19	.25	.30	
b1	.19	.22	.25	
c	.09	-	.20	
aaa	-	-	.10	
bbb	-	-	.10	
N	14			

TOLERANCES UNLESS SPECIFIED			2975 Stender Way Santa Clara, CA 95054	
DECIMAL	ANGULAR		PHONE: (408) 727-6116	
XX±	±	FAX: (408) 492-8674		
XXX±		www.IDT.com		
XXXX±		TITLE PGG/PGG PACKAGE OUTLINE (PG OR PA TOPMARK CODE) 4.4 mm BODY WIDTH TSSOP .65 mm PITCH		
SIZE	DRAWING No.	REV		
C	PSC-4056	08		
DO NOT SCALE DRAWING			SHEET 2 OF 3	

Package Outline and Dimensions (16-TSSOP, 4.4 mm body), cont.

DATE		REVISIONS	
CREATED	REV	DESCRIPTION	AUTHOR
08/25/98	02	ADD 14 & 16 LD	T. VU
07/10/99	03	ADD 8 LD	T. VU
5/23/01	04	ADDED TOPMARK TO TITLE	
10/14/04	05	ADD "GREEN" PGG NOMENCLATURE	TU VU
3/8/13	06	ADDED PACKAGE CODE	RAC
9/3/14	07	ADD TOLERANCE FOR A, A1, E AND b	CK LEE
3/10/17	08	ADD OPTION T1	R.TANH

NOTE: REFER TO DCP FOR OFFICIAL RELEASE DATE

LAND PATTERN DIMENSIONS

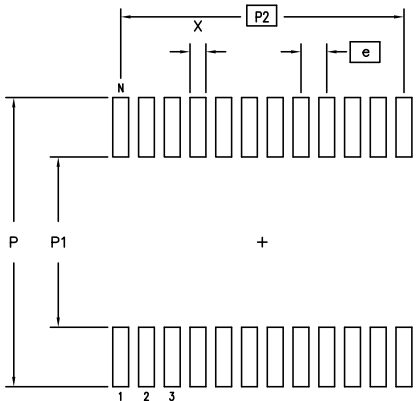

	MIN	MAX	MIN	MAX	MIN	MAX	MIN	MAX	MIN	MAX	MIN	MAX
P	7.20	7.40	7.20	7.40	7.20	7.40	7.20	7.40	7.20	7.40	7.20	7.40
P1	4.20	4.40	4.20	4.40	4.20	4.40	4.20	4.40	4.20	4.40	4.20	4.40
P2	1.95 BSC		3.90 BSC		4.55 BSC		5.85 BSC		7.15 BSC		8.45 BSC	
X	.30	.50	.30	.50	.30	.50	.30	.50	.30	.50	.30	.50
e	.65 BSC		.65 BSC		.65 BSC		.65 BSC		.65 BSC		.65 BSC	
N	8		14		16		20		24		28	

TOLERANCES UNLESS SPECIFIED DECIMAL    ANGULAR XX±        ± XXX± XXXX±	 2975 Stender Way Santa Clara, CA 95054 PHONE: (408) 727-6116 FAX: (408) 492-8674 www.IDT.com	TITLE PG/PGG PACKAGE OUTLINE (PG OR PA TOPMARK CODE) 4.4 mm BODY WIDTH TSSOP .65 mm PITCH	
		SIZE C	DRAWING No. PSC-4056
DO NOT SCALE DRAWING		SHEET 3 OF 3	

## Ordering Information

Part / Order Number	Marking	Shipping Packaging	Package	Temperature
5V41315PGGI	See Page 9	Tubes	16-pin TSSOP	-40 to +85° C
5V41315PGGI8		Tape and Reel	16-pin TSSOP	-40 to +85° C
5V41315NLGI		Trays	16-pin VFQFPN	-40 to +85° C
5V41315NLGI8		Tape and Reel	16-pin VFQFPN	-40 to +85° C

“G” after the two-letter package code denotes Pb-Free configuration, RoHS compliant.

## Revision History

Rev.	Date	Originator	Description of Change
A	10/24/12	J. Chao	Initial release—preliminary
B	03/20/13	R. Wade	1. Updated General Description verbiage. 2. Added 16-pin VFQFPN package and pinout 3. Updated pin descriptions for both TSSOP and VFQFPN 4. Minor updates to AC/DC char tables. 5. Updated Differential Phase Jitter Parameters table; removed typical specs, added 'tjphase12K20M' parameter. 6. Added 16-pin VFQFPN package drawing/dimensions, thermal characteristics, marking diagram, and ordering information
B	07/30/13	J. Chao	Updated device top-side marking on VFQFPN package; removed “G”.
C	09/20/13	RDW	Changed Rise/Fall times to differential slew rates.
D	06/01/15	IH	Added typical values to Differential Phase Jitter table.
E	05/08/17	C.P.	Updated package outline drawings and legal disclaimer.

**IDT5V41315**

**2 OUTPUT PCIE GEN1-2-3 SYNTHESIZER**



## IMPORTANT NOTICE AND DISCLAIMER

RENESAS ELECTRONICS CORPORATION AND ITS SUBSIDIARIES (“RENESAS”) PROVIDES TECHNICAL SPECIFICATIONS AND RELIABILITY DATA (INCLUDING DATASHEETS), DESIGN RESOURCES (INCLUDING REFERENCE DESIGNS), APPLICATION OR OTHER DESIGN ADVICE, WEB TOOLS, SAFETY INFORMATION, AND OTHER RESOURCES “AS IS” AND WITH ALL FAULTS, AND DISCLAIMS ALL WARRANTIES, EXPRESS OR IMPLIED, INCLUDING, WITHOUT LIMITATION, ANY IMPLIED WARRANTIES OF MERCHANTABILITY, FITNESS FOR A PARTICULAR PURPOSE, OR NON-INFRINGEMENT OF THIRD PARTY INTELLECTUAL PROPERTY RIGHTS.

These resources are intended for developers skilled in the art designing with Renesas products. You are solely responsible for (1) selecting the appropriate products for your application, (2) designing, validating, and testing your application, and (3) ensuring your application meets applicable standards, and any other safety, security, or other requirements. These resources are subject to change without notice. Renesas grants you permission to use these resources only for development of an application that uses Renesas products. Other reproduction or use of these resources is strictly prohibited. No license is granted to any other Renesas intellectual property or to any third party intellectual property. Renesas disclaims responsibility for, and you will fully indemnify Renesas and its representatives against, any claims, damages, costs, losses, or liabilities arising out of your use of these resources. Renesas' products are provided only subject to Renesas' Terms and Conditions of Sale or other applicable terms agreed to in writing. No use of any Renesas resources expands or otherwise alters any applicable warranties or warranty disclaimers for these products.

(Disclaimer Rev.1.0 Mar 2020)

### Corporate Headquarters

TOYOSU FORESIA, 3-2-24 Toyosu,  
Koto-ku, Tokyo 135-0061, Japan  
[www.renesas.com](http://www.renesas.com)

### Contact Information

For further information on a product, technology, the most up-to-date version of a document, or your nearest sales office, please visit:  
[www.renesas.com/contact/](http://www.renesas.com/contact/)

### Trademarks

Renesas and the Renesas logo are trademarks of Renesas Electronics Corporation. All trademarks and registered trademarks are the property of their respective owners.