

COUNT	DESCRIPTION OF REVISIONS	BY	CHKD	DATE	COUNT	DESCRIPTION OF REVISIONS	BY	CHKD	DATE
1	DIS-C-000585	T.K	E.K	07.07.27					

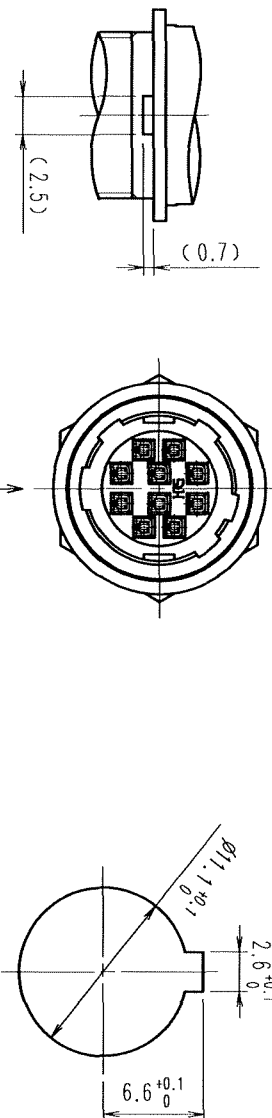

A DETAIL OF MOUNTING GUIDE

PANEL CUTOUT  
t = 0.7±0.2

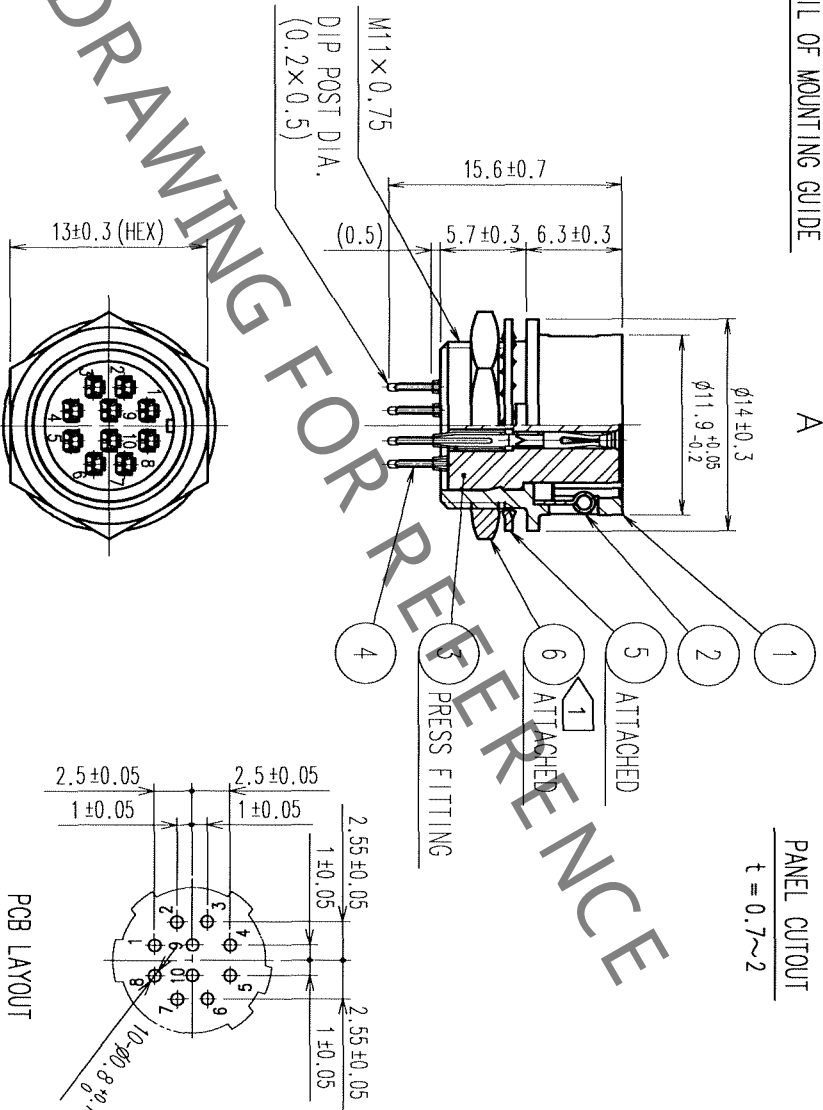

(INDICATES THE SIDE OF THE SURFACE TO WHICH DIP POSTS ARE INSERTED.)  
PCB LAYOUT

NOTE ① THE RECOMMENDED CLAMP TORQUE OF REF. NO. ⑥ TO BE 2 N · m.  
LOCTITE 242, HENKEL JAPAN OR EQUIVALENT IS RECOMMENDED TO PREVENT REF. NO. ⑥ FROM LOOSENING.

NO.	MATERIAL	FINISH, REMARKS	NO.	MATERIAL	FINISH, REMARKS
3	PBT	(BLACK) UL94V-0	6	BRASS	NICKEL PLATING
2	STAINLESS STEEL		5	PHOSPHOR BRONZE	NICKEL PLATING
1	ZINC ALLOY	MATTE FINISH NICKEL PLATED	4	PHOSPHOR BRONZE	GOLD PLATING 0.2μm min. NICKEL UNDER PLATING 2μm min.

CODE NO. (OLD)	DRAWN	DESIGNED	CHECKED	APPROVED	RELEASED
CL	H.KISHI	H.KISHI	E.KUNI I	M.SATO	
	'05 08 31	'05 08 31	'05 09 02	'05 09 02	

DRAWING NO.	PART NO.
EDC4-022531-72	HR10A-10R-10SB(72)

TO
R

SCALE	2 : 1
UNITS	mm

<b>HRS</b>	HIROSE ELECTRIC CO., LTD.
CODE NO.	CL110-0413-6-72
FORM NO.	NO.228