

STRAIGHT BULKHEAD JACK PANEL SEAL
REAR MOUNT CLAMP TYPE - CAB 2.6/50+75

R141.324.000

Series : BNC

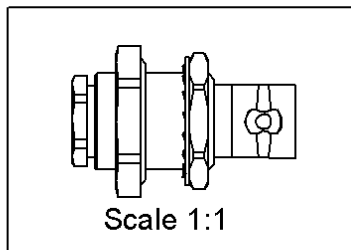
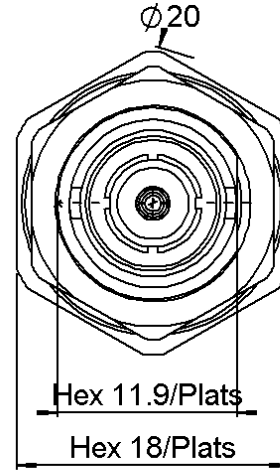
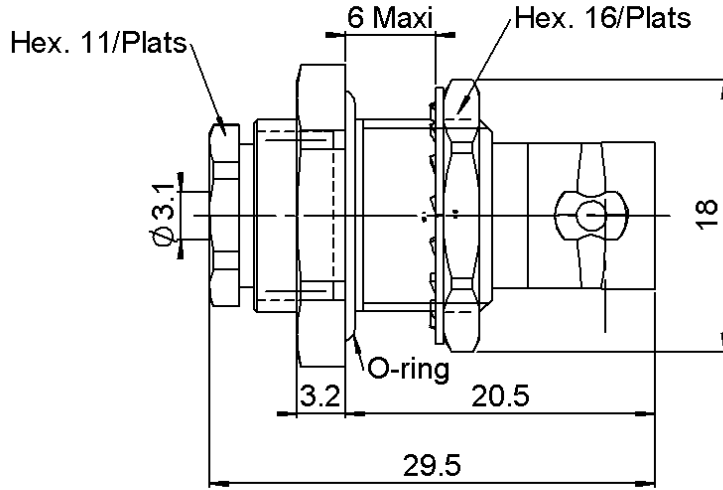

PANEL CUT OUT

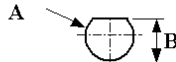

mm	
	Maxi mini
A	12.8 12.7
B	12.1 12

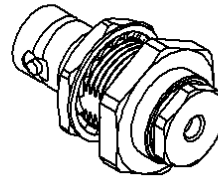

All dimensions are in mm.



COMPONENTS	MATERIALS	PLATING (µm)
BODY	BRASS	NICKEL 2
CENTER CONTACT	BERYLLIUM COPPER	GOLD 0.5 OVER NICKEL 2
OUTER CONTACT	-	-
INSULATOR	PTFE	-
GASKET	SILICONE RUBBER	-
OTHERS PARTS	BRASS	NICKEL 2
-	-	-
-	-	-

Issue : 0742 B

In the effort to improve our products, we reserve the right to make changes judged to be necessary.



STRAIGHT BULKHEAD JACK PANEL SEAL

R141.324.000

REAR MOUNT CLAMP TYPE - CAB 2.6/50+75

Series : **BNC**

PACKAGING

Standard	Unit	Other
100	'W' option	Contact us

SPECIFICATION

ELECTRICAL CHARACTERISTICS

Impedance		50	Ω
Frequency		0-4	GHz
VSWR	AD +	0,0000	x F(GHz) Maxi
Insertion loss		0.115	\sqrt{F} (GHz) dB Maxi
RF leakage	- (-	- F(GHz)) dB Maxi
Voltage rating		335	Veff Maxi
Dielectric withstanding voltage		1500	Veff mini
Insulation resistance		5000	M Ω mini

CABLE ASSEMBLY

Stripping	a	b	c	d	e	f
mm	4,00	2,00	9,00	0,00	5,00	0,00

Assembly instruction : **Clamp 01**

Recommended cable(s)

RG 316
RG 188
RG 187
RG 179
KX 22A

Characteristics indicated on this data sheet are those that can be achieved with the highest performance cable. Intrinsic limitations of the cable may diminish the performance of the assembly

Cable retention

- pull off **110** N mini
- torque - N.cm

MECHANICAL CHARACTERISTICS

Center contact retention			
Axial force – Mating end		27	N mini
Axial force – Opposite end		27	N mini
Torque		N/A	N.cm mini

TOOLING

Part Number	Description	Hexagon
.	.	.

Recommended torque			
Mating		N/A	N.cm
Panel nut		370	N.cm
Clamp nut		450	N.cm
A/F clamp nut		0,0000	mm

OTHER CHARACTERISTICS

Mating life		500	Cycles mini
Weight		24,7610	g

ENVIRONMENTAL

Operating temperature		-65/+165	$^{\circ}$ C
Hermetic seal		NA	Atm.cm3/s
Panel leakage		N/A	

Issue : **0742 B**

In the effort to improve our products, we reserve the right to make changes judged to be necessary.

