

NOTES:

- MATERIAL:
BODY- BLACK ABS POLYAC PA-765
COVER- BLACK ABS POLYAC PA-765
TEXTURED/FLUSH OR RECESSED SMOOTH
- UL94 VO(1.5mm) AND 5VA (3mm) FLAMMABILITY RATING.
- COVER IS REMOVABLE
- DIMENSIONS ARE INCH [MM]

DRAWING FOR REFERENCE

WE RESERVE THE RIGHT TO MAKE CHANGES TO OUR STANDARD PRODUCTS. PLEASE CONSULT WITH BUD INDUSTRIES PRIOR TO USING THIS DRAWING FOR DESIGN PURPOSE.

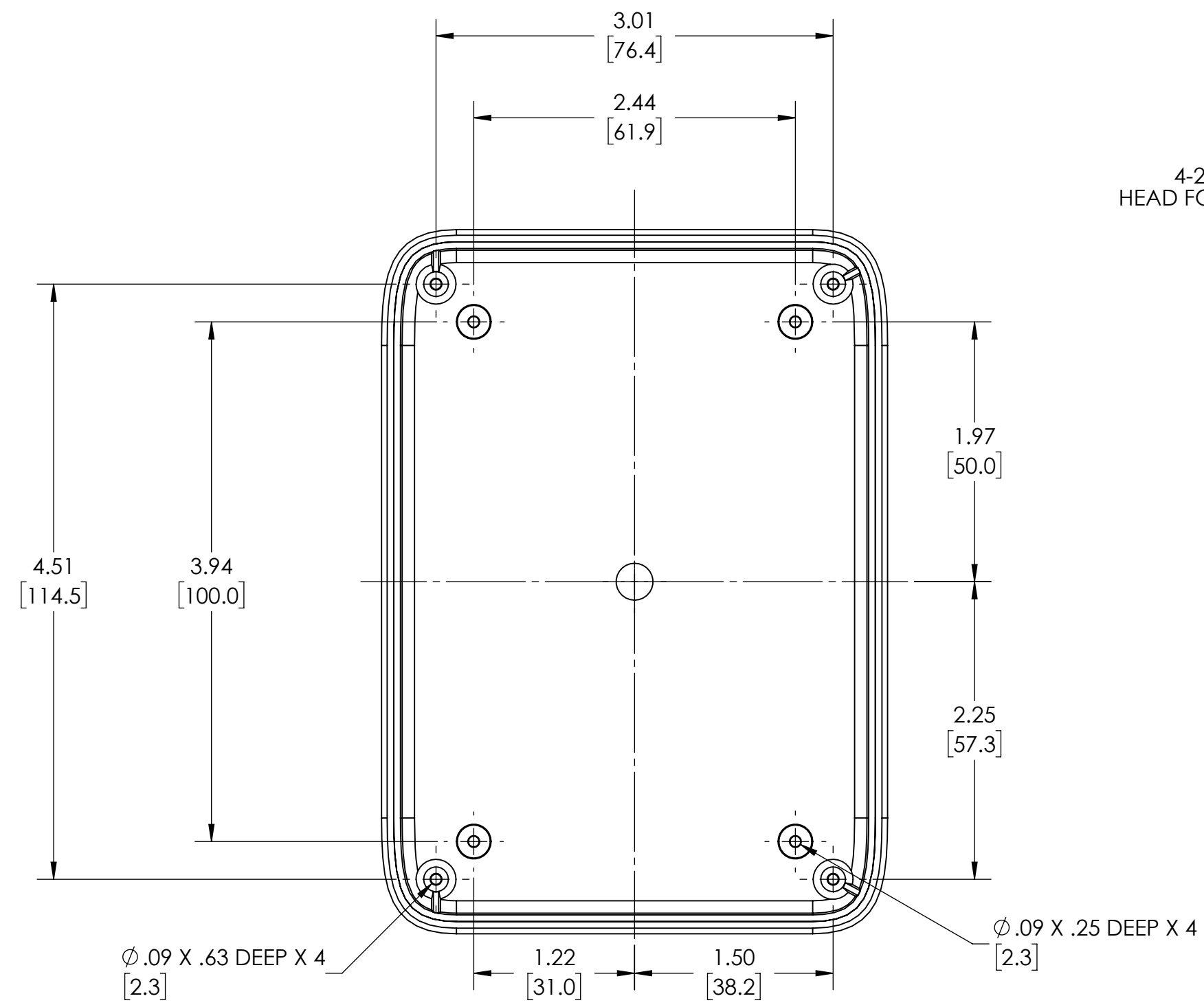

INSIDE VIEW OF BODY
COVER NOT SHOWN

4-24 X .5 CROSS OVAL
HEAD FORMING SCREW X 4

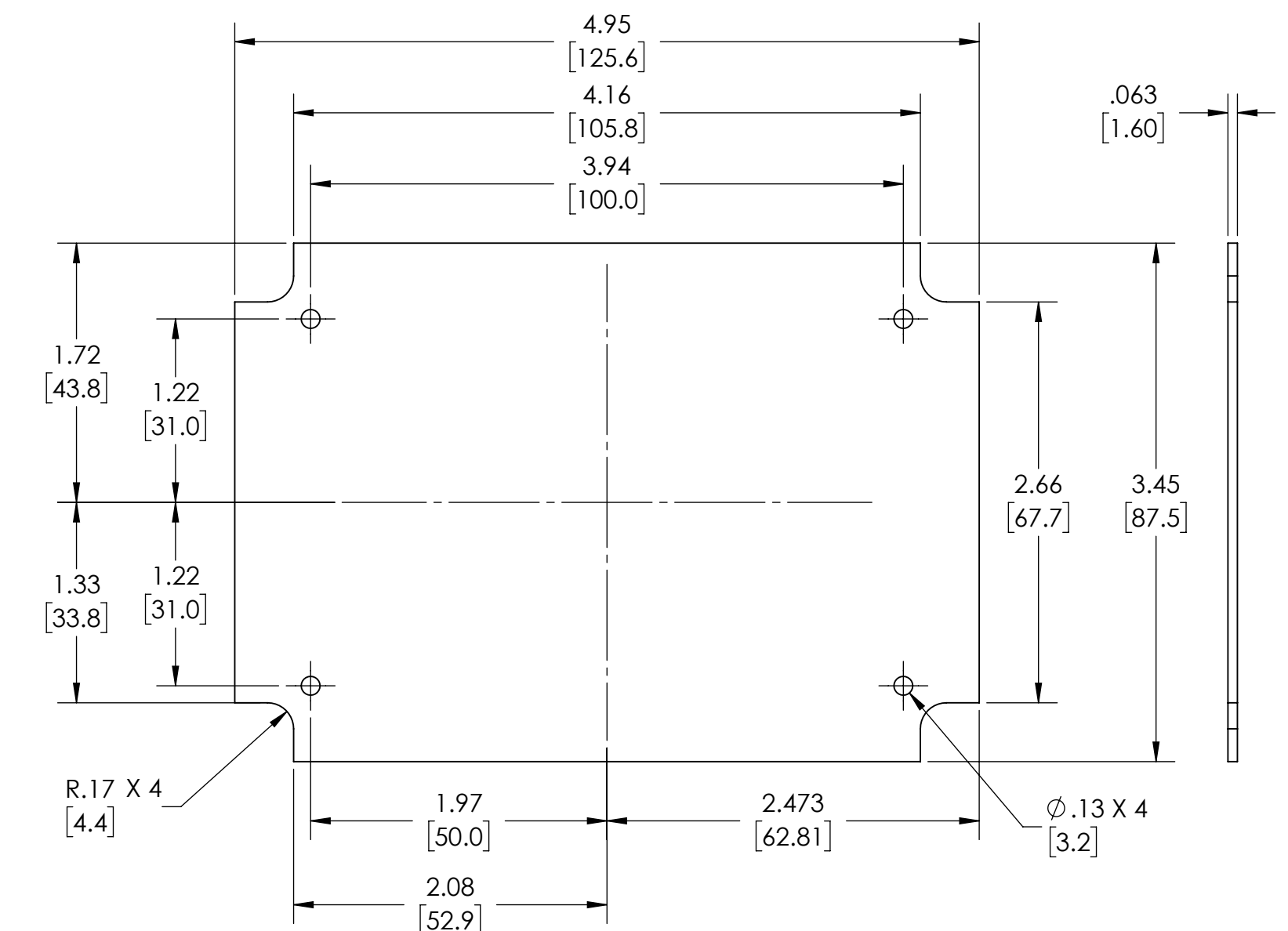
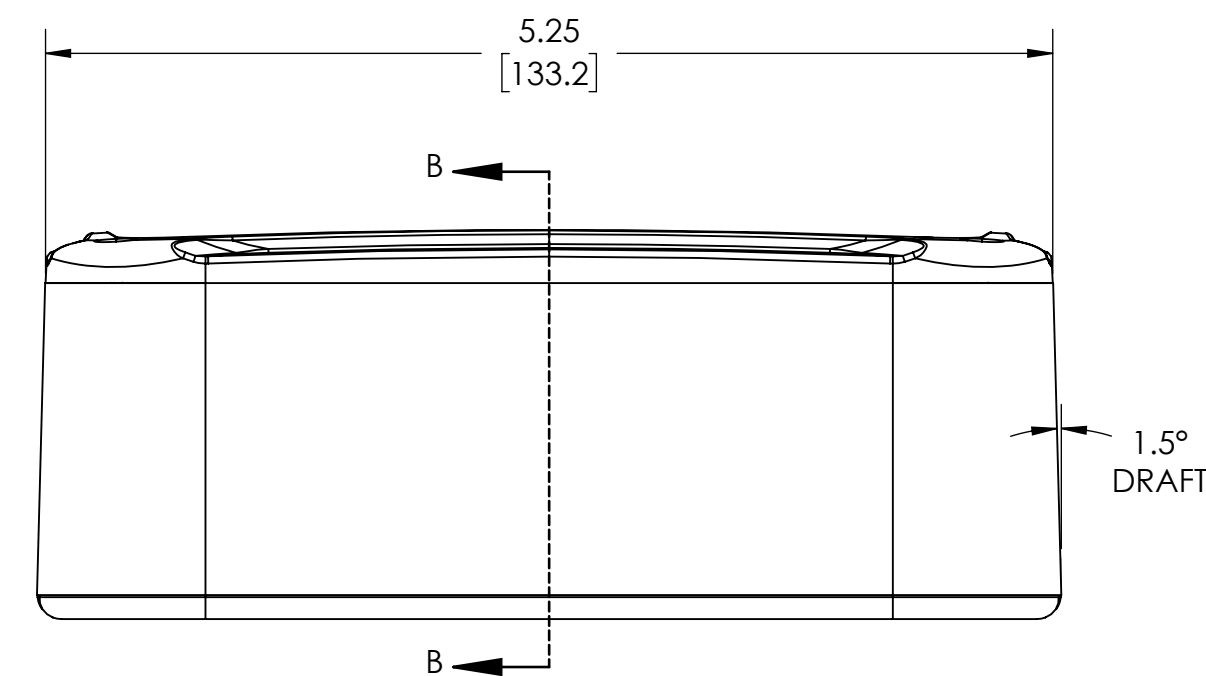
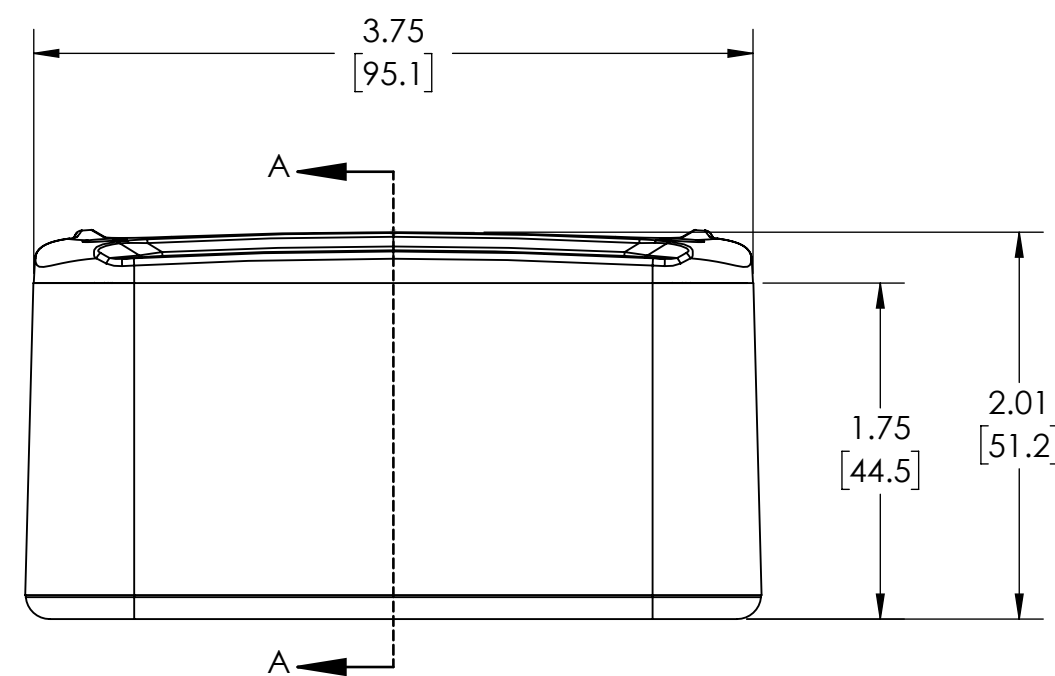
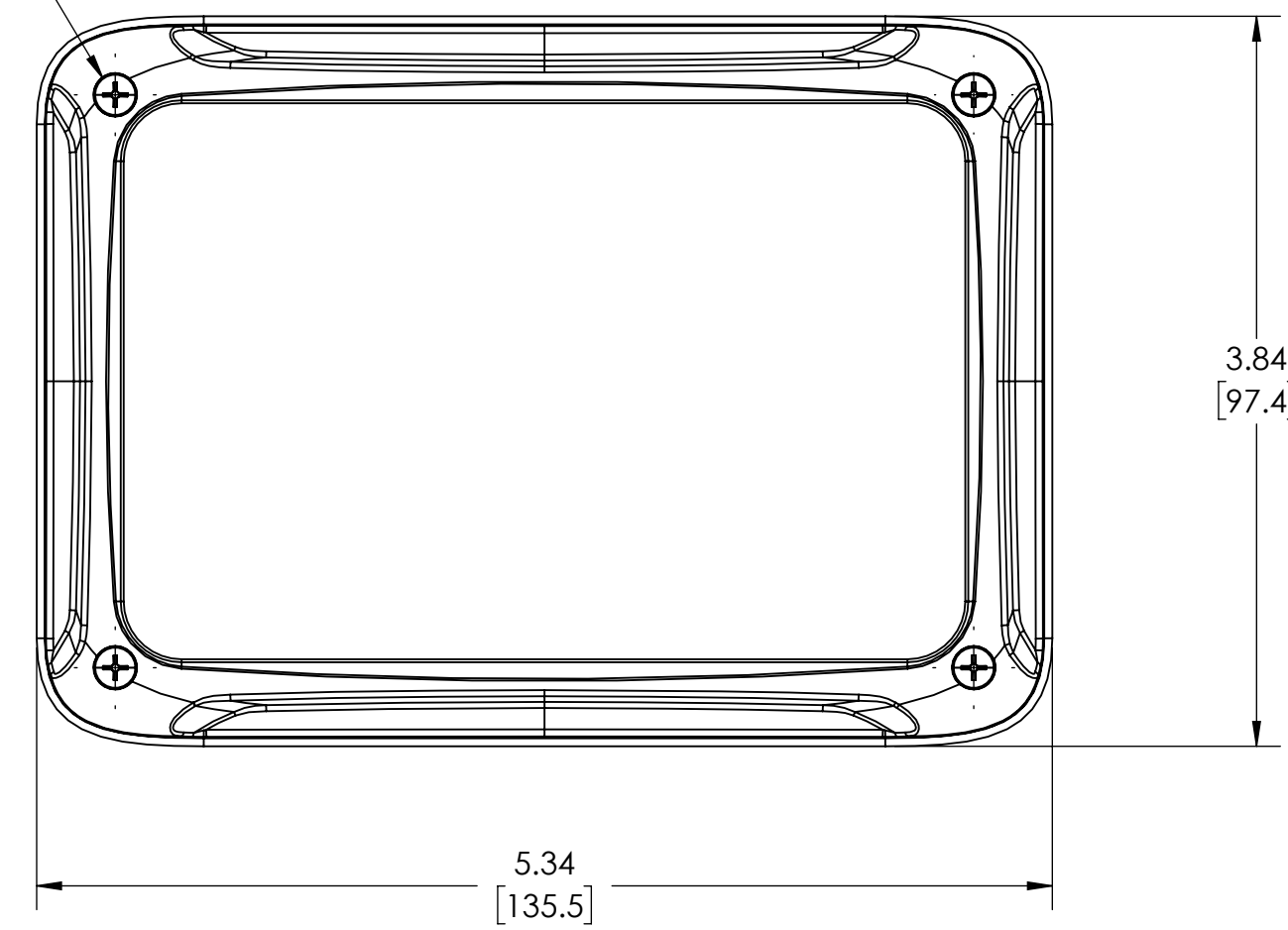

SUGGESTED PCB LAYOUT

