

REVISIONS				
P	LTR	DESCRIPTION	DATE	APVD
A		INITIAL RELEASE PER D09-004	10MAR2009	DD RB
B		REVISED PER ECO-13-019865	27DEC2013	DR RB

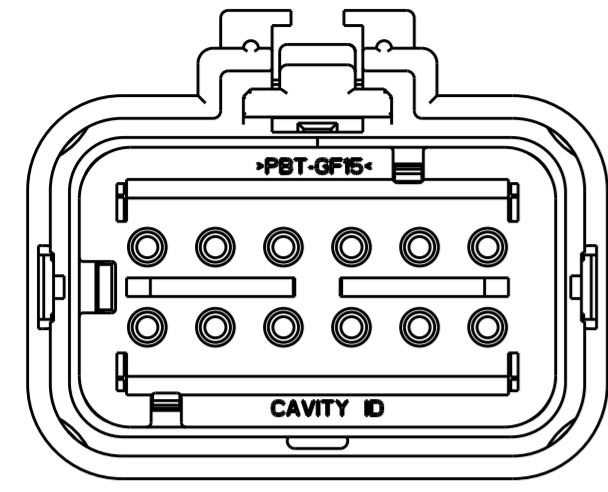

2035559-2  
(KEY B)  
SCALE 2:1

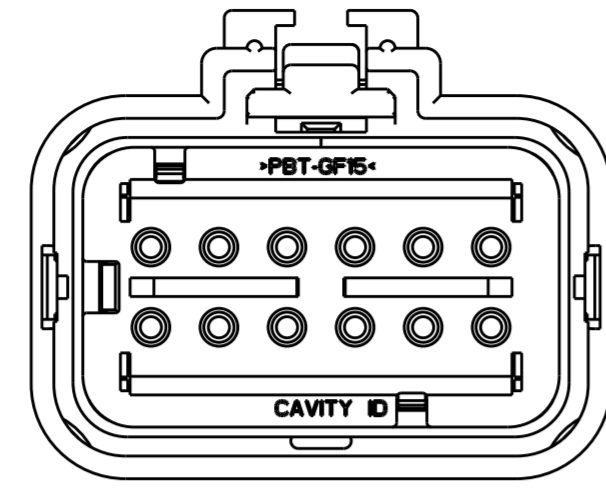

2035559-3  
(KEY C)  
SCALE 2:1

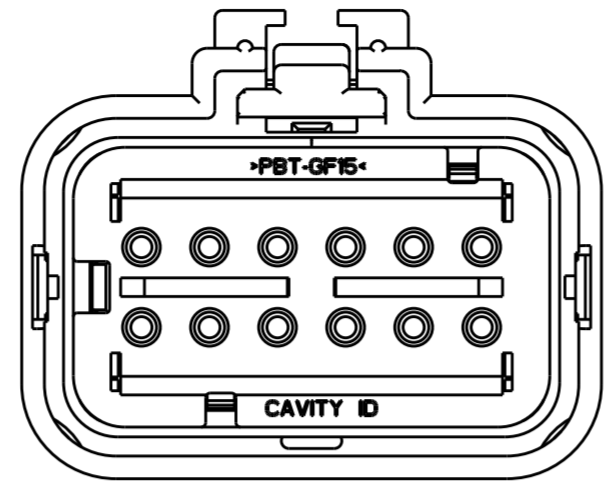

2035559-4  
(KEY D)  
SCALE 2:1

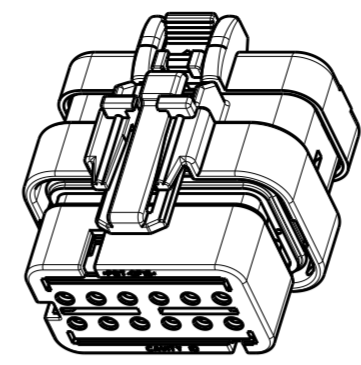

SCALE 1:1

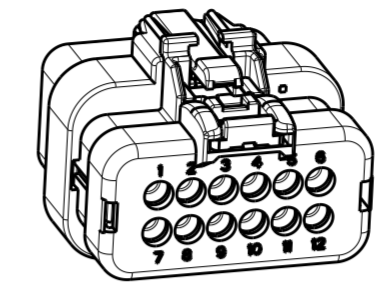

SCALE 1:1

- 1 MATERIAL: 25% GLASS FILLED, NYLON 6/6, VO  
COLOR: NATURAL (BROWN)
  - 2 MATERIAL: 20% GLASS FILLED, PBT, VO  
COLOR: (SEE TABLE)
  - 3 MATERIAL: SILICONE  
COLOR: GREEN
  - 4 MATERIAL: 20% GLASS FILLED THERMOPLASTIC  
COLOR: ORANGE
  - 5 MATERIAL: SILICONE  
COLOR: TAN
6. RECOMMENDED WIRE DIAMETER RANGE:  
2.18 TO 3.67mm.

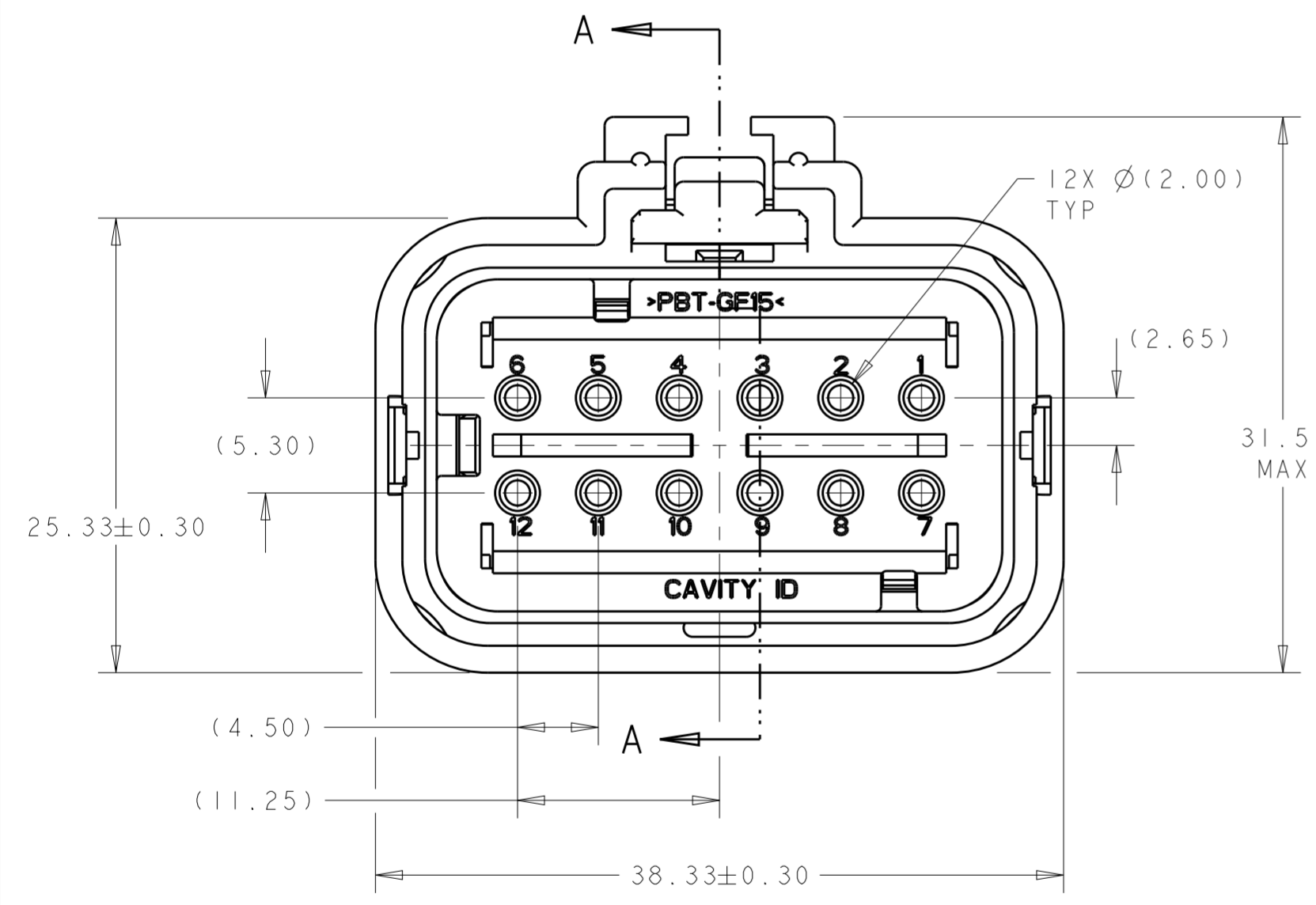

2035559-1 SHOWN  
(KEY A)

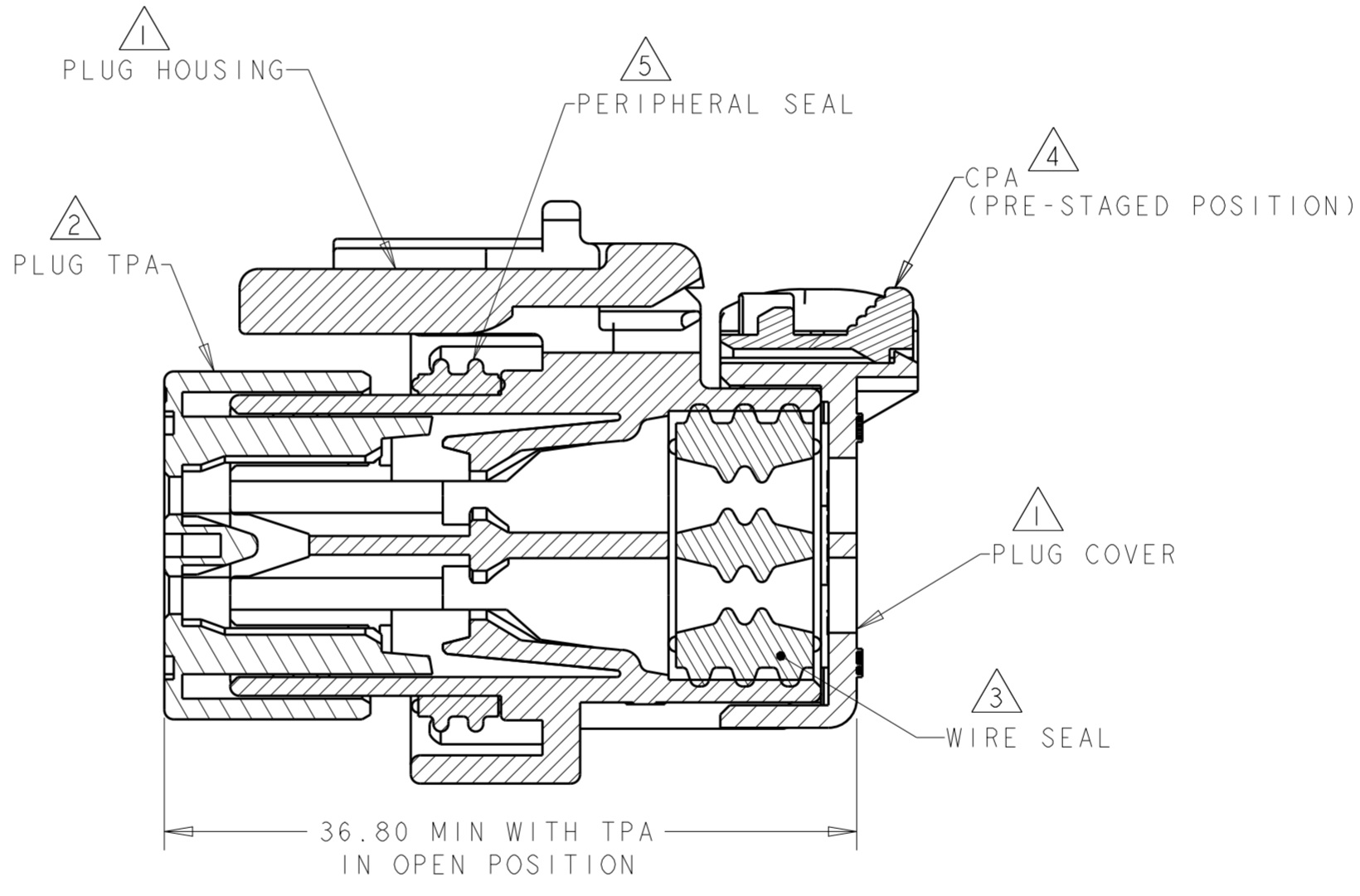

SECTION A-A

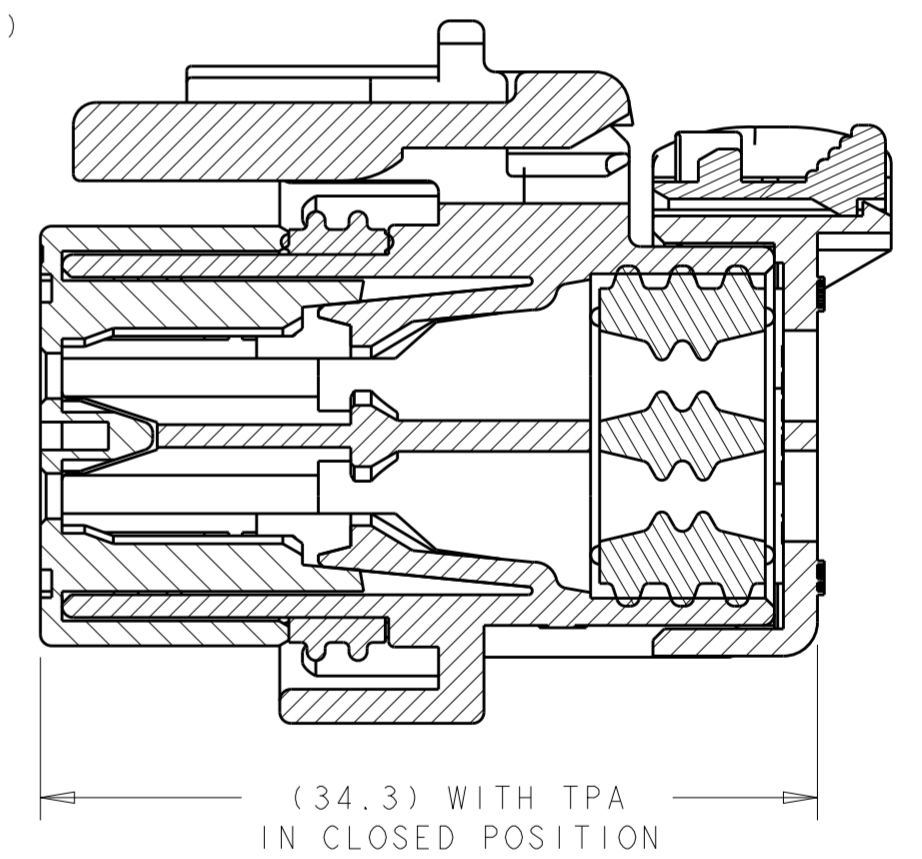

SECTION A-A

TAN	D	2035559-4
BLUE	C	2035559-3
PURPLE	B	2035559-2
ORANGE	A	2035559-1
TPA COLOR	KEY	PART NUMBER

THIS DRAWING IS A CONTROLLED DOCUMENT.		DWN 06FEB2009 DI DRUMMOND	TE Connectivity	
DIMENSIONS: mm		CHK 06FEB2009 R. BALTER		
TOLERANCES UNLESS OTHERWISE SPECIFIED:		APVD 06FEB2009 R. BALTER	NAME	
0 PLC ±	1 PLC ±	PRODUCT SPEC	PLUG ASSEMBLY, 12 POSITION, DUAL ROW, AMPSEAL 16, VO	
2 PLC ±0.20	3 PLC ±	108-2184	SIZE	CAGE CODE
4 PLC ±	ANGLES ±	114-13065	A2	0779
MATERIAL -	FINISH -	WEIGHT 20±1g	DRAWING NO C-2035559	
CUSTOMER DRAWING		SCALE 3:1	SHEET	OF
				REV B