

LOC		DIST		REVISIONS			
P	LTR	DESCRIPTION	DATE	DNW	APVD		
AD	REV PER ECO	15-016064	11-9-15	CT	CD		

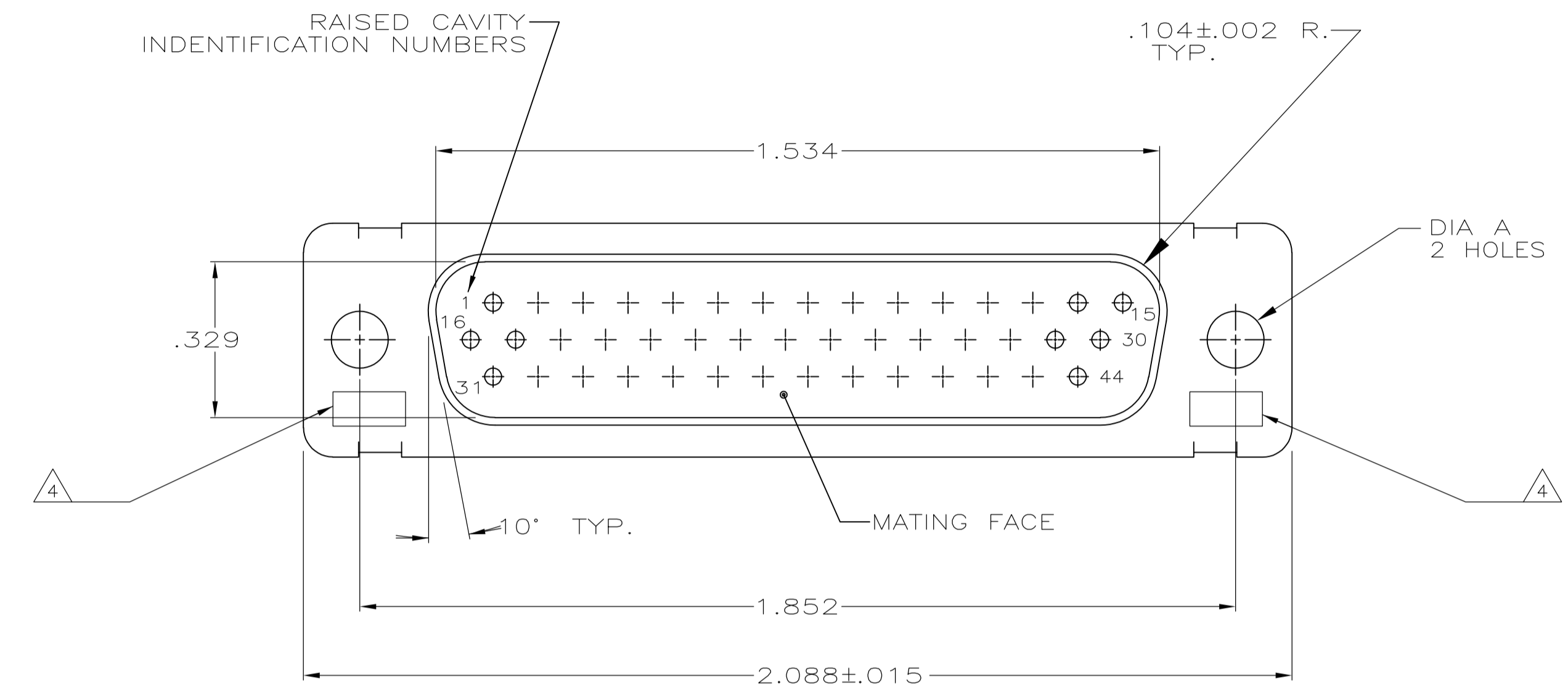

1. THIS PLUG WILL MATE WITH ANY RECEPTACLE CONNECTOR WITH THE SAME INSERT ARRANGEMENT AS DEFINED BY MS18275-2.
2. MAXIMUM WIRE INSULATION USED WITH THIS RCPT. IS .054 DIA.
3. Be-Cu RETENTION CLIPS ARE INCLUDED IN INSERTS.
4. UL/CSA DESIGNATION MARKED IN THIS AREA, OPTIONAL.
5. INSPECTION REQUIREMENTS PER R4383.
6. CONNECTOR SUPPLIED WITH 49 CONTACTS, MFG'S PART NUMBER 204370-8. INSPECTION REQUIREMENTS PER R4383 WITHOUT TESTS FOR HIGH ALTITUDE DIELECTRIC WITHSTANDING VOLTAGE AS CALLED FOR IN TABLE II SCREENING AND TESTING.
7. THESE CONNECTORS ARE QUALIFIED TO GODDARD SPACE FLIGHT CENTER SPECIFICATION S-311-P-4.
8. 54 CONTACTS, MFG'S PART NUMBER 204370-8, SUPPLIED WITH EACH CONNECTOR
9. CONNECTOR LOADED WITH POSTED CONTACTS. INSPECTION REQUIREMENTS PER GENERAL ELECTRIC DOCUMENT 20025720.
10. RESTRICTED TO CAE ELECTRONICS ONLY.

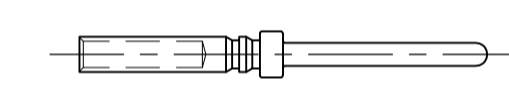
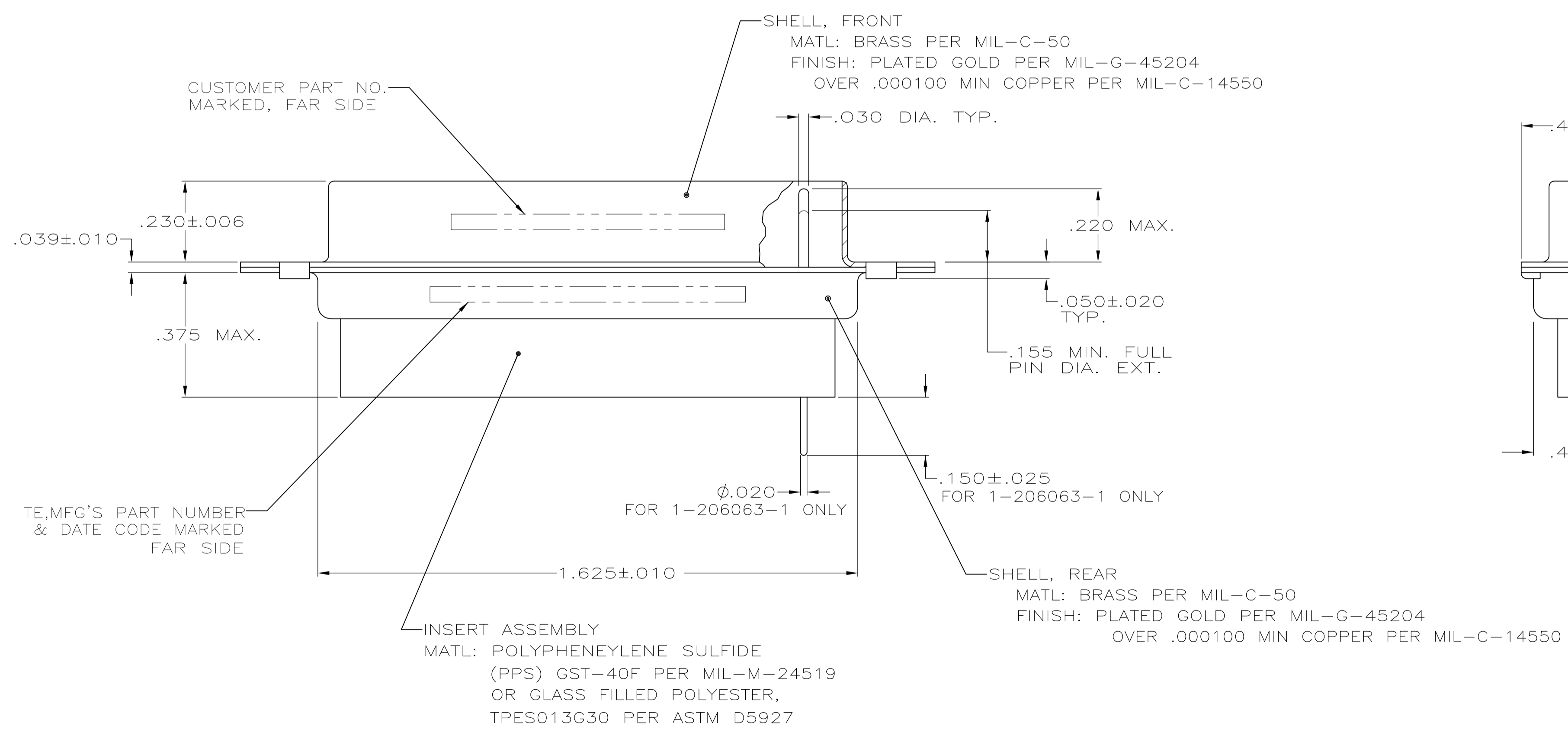

CONTACT P/N 204370-8  
GSFC G-08-P1  
(SUPPLIED WITH 206063-7 AND 1-206063-0 ONLY)

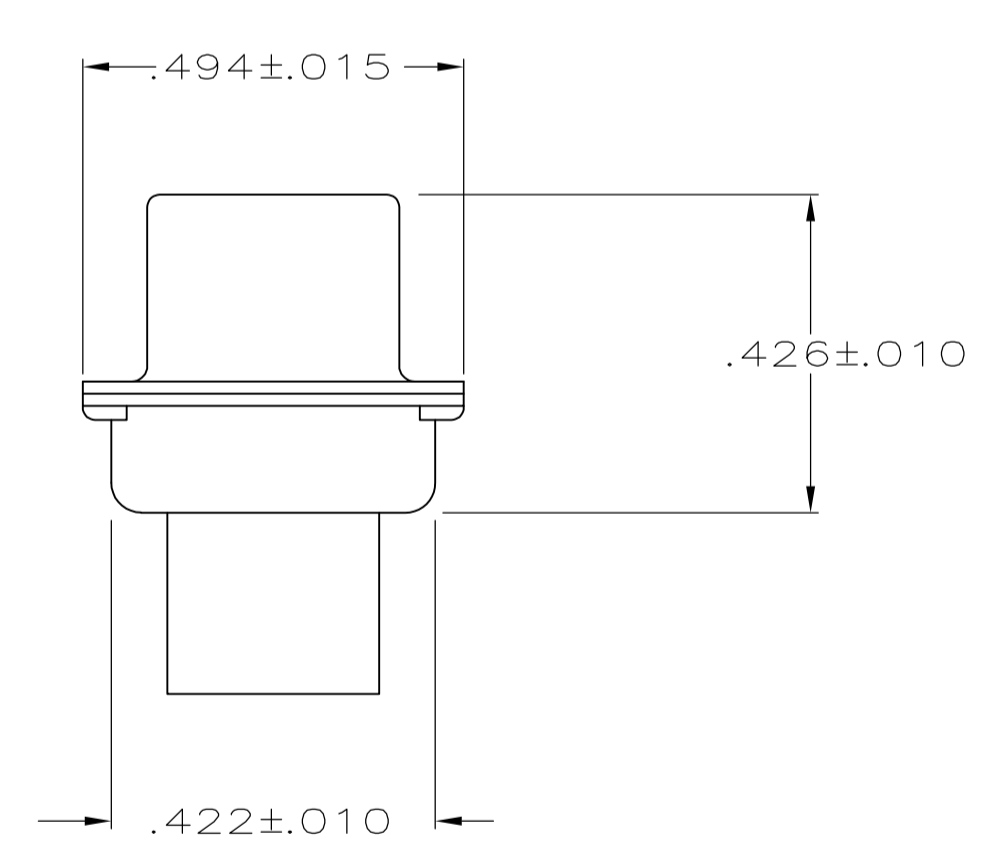

7	.120	570566-9	1-206063-3	1-206063-3
10	.120	311P407-3P-B-12	1-206063-2	1-206063-2
9	.120	20025720P2044P	1-206063-1	1-206063-1
8	.120	3261113-11	1-203063-0	1-203063-0
	.120	1622251-002	206063-9	206063-9
	.120	7636-5	206063-8	206063-8
6	.120	R4383P44P	206063-7	206063-7
	.120		206063-6	206063-6
5	.120	R4383P44P	206063-5	206063-5
7	.120	311P407-3P-B-12	206063-4	206063-4
	.154		206063-3	206063-3
7	.154	311P407-3P-B-15	206063-2	206063-2
	.120	R9259P44P	206063-1	206063-1
REMARKS	DIA A	MARKED CUSTOMER P/N	MARKED AMP P/N	MFG'S PART NUMBER

THIS DRAWING IS A CONTROLLED DOCUMENT.

DIMENSIONS: INCHES	TOLERANCES UNLESS OTHERWISE SPECIFIED:	DIN	M. CLOUSER	12-9-90
0 PLC ± -	1 PLC ± -	CHK	F.J. KINSEY	11-19-91
2 PLC ± -	3 PLC ± .005	APVD	F. KINSEY	11-19-91
4 PLC ± -	ANGLES ± -	NAME	PLUG, PIN CONTACTS HI-DENSITY HDD CONNECTOR SIZE 3 (44 POSN)	
MATERIAL SEE CALLOUTS	FINISH SEE CALLOUTS	WEIGHT	SIZE	CAGE CODE
			A1	00779
			SCALE	4:1
			SHEET	1 of 1
			REV	AD

CUSTOMER DRAWING