

Product Specification

(Preliminary)

Part Name: OLED Display

Part ID: LY112WG22-128128

PREPARED BY	CHECKED BY	APPROVED BY

LI YUAN ELECTRONICS CO., LTD.

Notes:

1. Please contact Li Yuan Electronics Co., Ltd. before assigning your product based on this module specification.
2. The information contained herein is presented merely to indicate the characteristics and performance of our products. No responsibility is assumed by Li Yuan Electronics Co., Ltd. For any intellectual property claims or other problems that may result from application based on the module described

PRODUCT CONTENTS

- **PHYSICAL DATA**
- **ABSOLUTE MAXIMUM RATINGS**
- **EXTERNAL DIMENSIONS**
- **ELECTRICAL CHARACTERISTICS**
- **TIMING OF POWER SUPPLY**
- **ELECTRO-OPTICAL CHARACTERISTICS**
- **INTERFACE PIN CONNECTIONS**
- **COMMAND TABLE**
- **INITIALIZATION CODE**
- **SCHEMATIC EXAMPLE**
- **RELIABILITY TESTS**
- **OUTGOING QUALITY CONTROL SPECIFICATION**
- **CAUTIONS IN USING OLED MODULE**

REVISION HISTORY

Rev.	Contents	Date
1.0	First release	2017-05-14

■ PHYSICAL DATA

No.	Items:	Specification:	Unit
1	Diagonal Size	1.12	Inch
2	Resolution	128(H) x 128(V)	Dots
3	Active Area	20.14(W) x 20.14(H)	mm ²
4	Outline Dimension (Panel)	27.00 (W) x 30.10(H)	mm ²
5	Pixel Pitch	0.1575(W) x 0.1575(H)	mm ²
6	Pixel Size	0.1375(W) x 0.1375(H)	mm ²
7	Driver IC	SH1107G	-
8	Display Color	White	-
9	Grayscale	1	Bit
10	Interface	8bit-6800/8080,4-SPI,I2C	-
11	IC package type	COG	-
12	Thickness	1.25±0.1	mm
13	Weight	2.0	g
14	Duty	1/128	-

■ ABSOLUTE MAXIMUM RATINGS

 Unless otherwise specified,(Voltage Referenced to V_{SS})

(Ta = 25°C)

Items		Symbol	Min	Typ.	Max	Unit
Supply Voltage	Logic	V _{DD}	-0.3	-	3.6	V
	Driving	V _{PP}	-0.3	-	17.0	V
Operating Temperature		Top	-40	-	70	°C
Storage Temperature		Tst	-40	-	85	°C
Humidity		-	-	-	90	%RH

NOTE:

Permanent device damage may occur if ABSOLUTE MAXIMUM RATINGS are exceeded.

Functional operation should be restricted to the conditions as detailed in the operational sections of this data sheet. Exposure to absolute maximum rating conditions for extended periods may affect reliability.

EXTERNAL DIMENSIONS

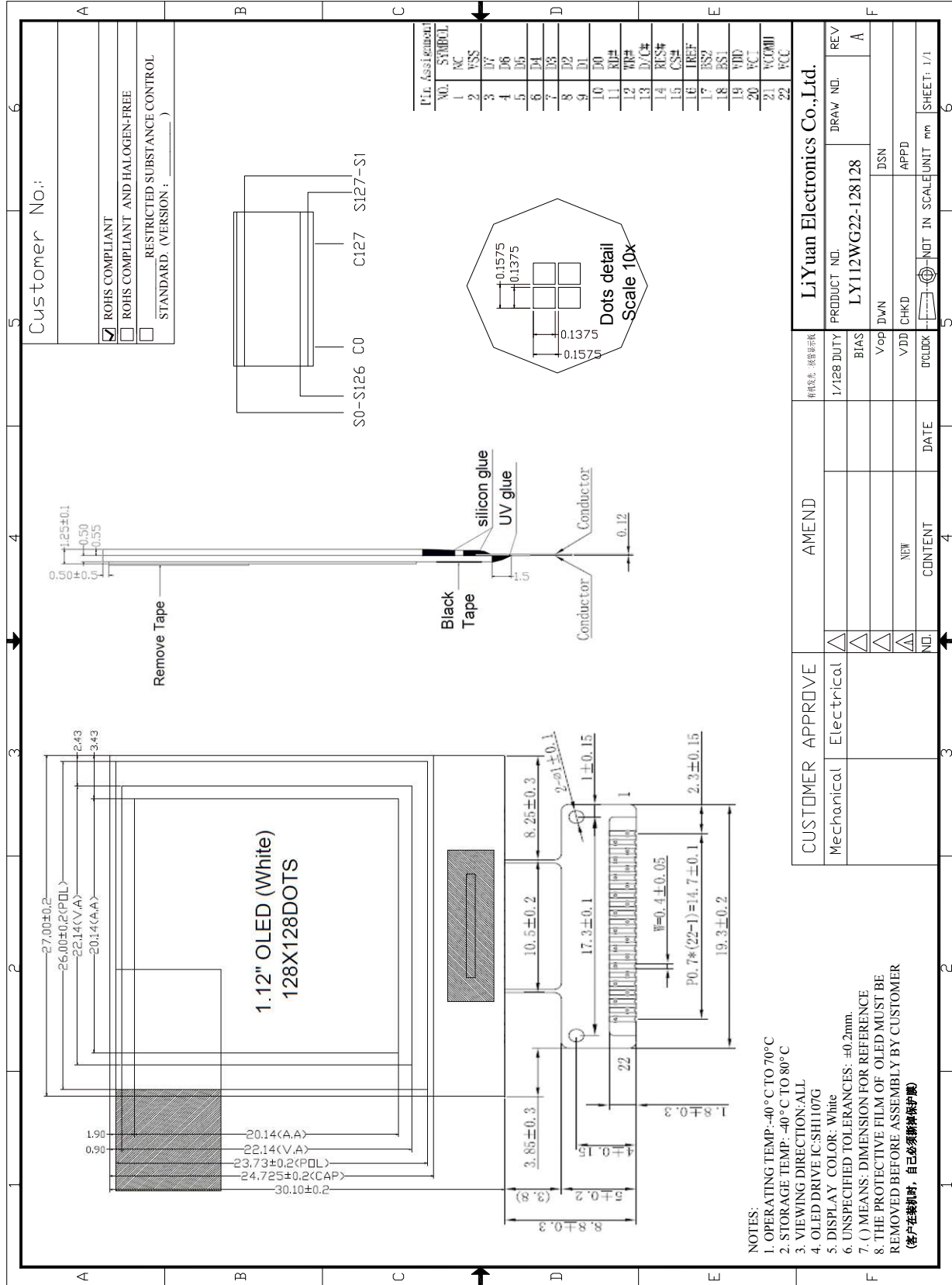

■ ELECTRICAL CHARACTERISTICS**◆ DC Characteristics**Condition(Unless otherwise specified): Voltage referenced to VSS $V_{DD}=1.65V$ to $3.5V$ $T_a = 25^{\circ}C$

	Items	Symbol	Min	Typ.	Max	Unit
Supply Voltage	Logic	V_{DD}	1.65	3.0	3.5	V
	Operating	V_{PP}	7.0	11.0	16.5	V
Input Voltage	High Voltage	V_{IH}	$0.8 \times V_{DD}$	-	V_{DD}	V
	Low Voltage	V_{IL}	VSS	-	$0.2 \times V_{DD}$	V
Output Voltage	High Voltage	V_{OH}	$0.8 \times V_{DD}$	-	V_{DD}	V
	Low Voltage	V_{OL}	VSS	-	$0.2 \times V_{DD}$	V

◆ AC Characteristics

1. 8080 Serial Interface Timing Characteristics

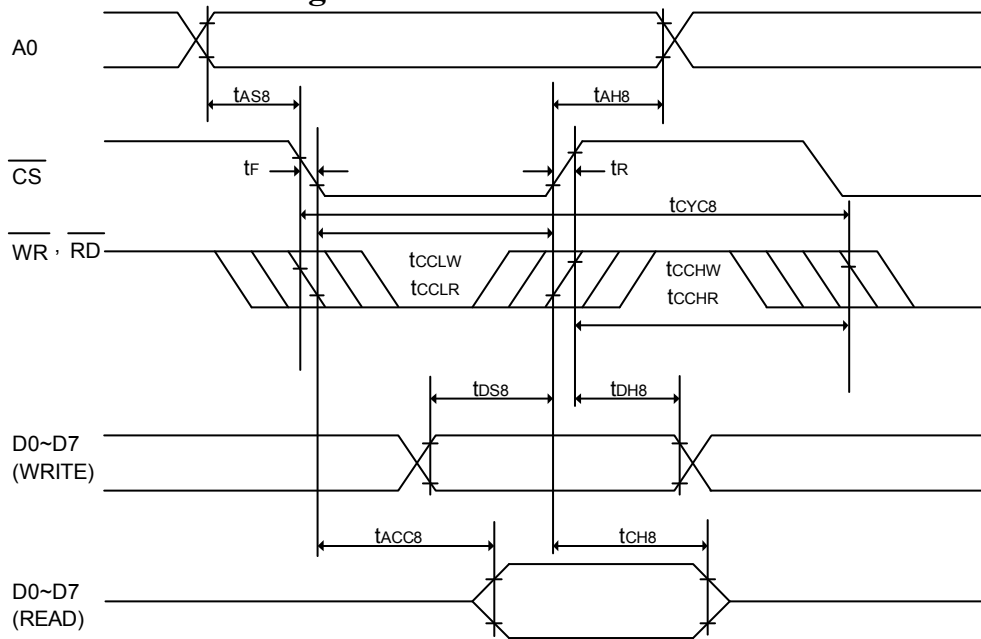

($V_{DD} = 1.65V - 2.4V, T_A = +25^\circ C$)

Symbol	Parameter	Min.	Typ.	Max.	Unit	Condition
t_{CYC8}	System cycle time	300	-	-	ns	
t_{AS8}	Address setup time	0	-	-	ns	
t_{AH8}	Address hold time	0	-	-	ns	
t_{DS8}	Data setup time	40	-	-	ns	
t_{DH8}	Data hold time	30	-	-	ns	
t_{CH8}	Output disable time	10	-	70	ns	$C_L = 100pF$
t_{ACC8}	\overline{RD} access time	-	-	280	ns	$C_L = 100pF$
t_{CCLW}	Control L pulse width (WR)	100	-	-	ns	
t_{CCLR}	Control L pulse width (RD)	120	-	-	ns	
t_{CCHW}	Control H pulse width (WR)	100	-	-	ns	
t_{CCHR}	Control H pulse width (RD)	100	-	-	ns	
t_r	Rise time	-	-	15	ns	
t_f	Fall time	-	-	15	ns	

(V_{DD} = 2.4V – 3.5V, T_A = +25°C)

Symbol	Parameter	Min.	Typ.	Max.	Unit	Condition
t _{CYC8}	System cycle time	300	-	-	ns	
t _{AS8}	Address setup time	0	-	-	ns	
t _{AH8}	Address hold time	0	-	-	ns	
t _{DS8}	Data setup time	40	-	-	ns	
t _{DH8}	Data hold time	15	-	-	ns	
t _{CH8}	Output disable time	10	-	70	ns	C _L = 100pF
t _{ACC8}	\overline{RD} access time	-	-	140	ns	C _L = 100pF
t _{CCLW}	Control L pulse width (WR)	100	-	-	ns	
t _{CCLR}	Control L pulse width (RD)	120	-	-	ns	
t _{CCHW}	Control H pulse width (WR)	100	-	-	ns	
t _{CCHR}	Control H pulse width (RD)	100	-	-	ns	
t _R	Rise time	-	-	15	ns	
t _F	Fall time	-	-	15	ns	

8bit-6800/4-SPI/I2C Serial Interface Timing Characteristics

Refer to SH1107G IC Specification.

2. Reset Timing

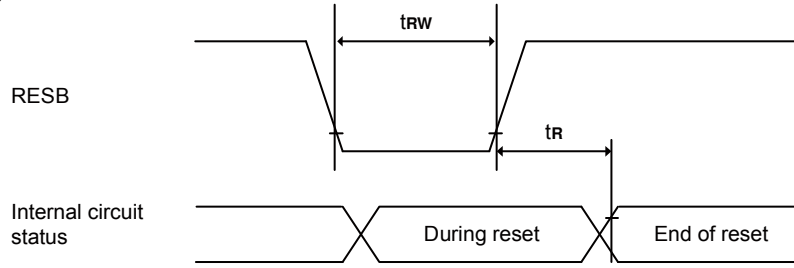

(V_{DD} = 1.65 - 3.5V, T_A = +25 C)

Symbol	Parameter	Min.	Typ.	Max.	Unit	Condition
t _R	Reset time	-	-	2.0	s	
t _{RW}	Reset low pulse width	10.0	-	-	s	

3. Power on and off sequence

Power on sequence :

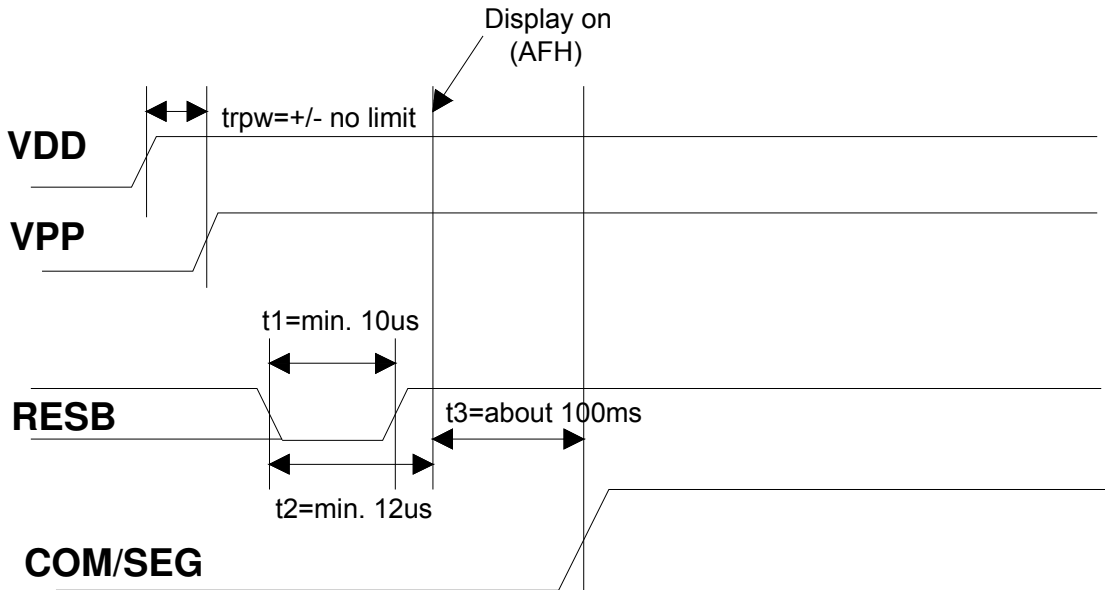

Power off sequence :

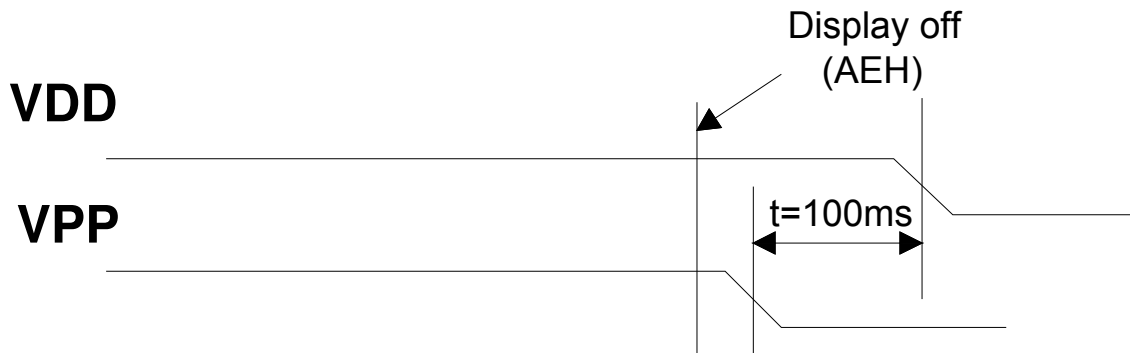

■ ELECTRO-OPTICAL CHARACTERISTICS (Ta=25°C)

Items		Symbol	Min.	Typ.	Max.	Unit	Remark
Operating Luminance		L	60	80	-	cd /m ²	All pixels ON
Power Consumption		P	-	80	90	mW	30% pixels ON
Frame Frequency		Fr	-	105	-	Hz	-
Color Coordinate	White	CIE x	0.21	0.25	0.29	CIE1931	Darkroom
		CIE y	0.26	0.30	0.34		
Response Time	Rise	Tr	-	-	0.02	ms	-
	Decay	Td	-	-	0.02	ms	-
Contrast Ratio		Cr	5000:1	-	-	-	Darkroom
Viewing Angle		△ θ	160	-	-	Degree	-
Operating Life Time		Top	25,000	-	-	Hours	L=80cd/m ²

Note:

- L=80 cd/m² is based on VDD=3.0V , VPP=11.0V, contrast command setting 0xA0;
- Contrast ratio is defined as follows:

$$\text{Contrast ratio} = \frac{\text{Photo – detector output with OLED being “white”}}{\text{Photo – detector output with OLED being “black”}}$$

- Life Time is defined when the Luminance has decayed to less than 50% of the initial Luminance specification. (Odd and even chess board alternately displayed)
(The initial value should be closed to the typical value after adjusting.)

■ INTERFACE PIN CONNECTIONS

PIN NO.	PIN NAME	DESCRIPTION
1	NC	No Connection.
2	VSS	Ground.
3~10	D7~D0	Data bus.
11	RD#	This pin is MCU interface input.
12	WR#	This pin is read / write control input connecting to the MCU interface.
13	D/C#	Data/Command Select. H: Data; L: Command.
14	RES#	Reset, active low.
15	CS#	Chip Select, active low.
16	IREF	This is a segment current reference pin.
17~18	BS2~BS1	Table:1
19	VDD	Power supply pin for core logic operation.
20	VCI	Low voltage power supply and power supply for interface logic level.
21	VCOMH	This is an input pin for the voltage output high level for COM signals.
22	VCC	OLED drive voltage, it should be supplied externally.

Table:1

BS[2:1]	Interface
00	4-line SPI
01	I ² C
11	8-bit 8080
10	8-bit 6800

■ COMMAND TABLE

Command	Code											Function
	A0	\overline{RD}	\overline{WR}	D7	D6	D5	D4	D3	D2	D1	D0	
1. Set Column Address 4 lower bits	0	1	0	0	0	0	0	Lower column address				Sets 4 lower bits of column address of display RAM in register. (POR = 00H)
2. Set Column Address 4 higher bits	0	1	0	0	0	0	1	0	Higher column address			Sets 4 higher bits of column address of display RAM in register. (POR = 10H)
3. Set memory addressing mode	0	1	0	0	0	1	0	0	0	0	D	D = 1, Vertical Addressing Mode D = 0, Page Addressing Mode (POR=20H)
4. The Contrast Control Mode Set Contrast Data Register Set	0	1	0	1	0	0	0	0	0	0	1	This command is to set Contrast Setting of the display. The chip has 256 contrast steps from 00 to FF. (POR = 80H)
	0	1	0	Contrast Data								
5. Set Segment Re-map (ADC)	0	1	0	1	0	1	0	0	0	0	ADC	The down (0) or up (1) rotation. (POR = A0H)
6. Set Multiplex Ration	0	1	0	1	0	1	0	1	0	0	0	This command switches multiplex mode to any multiplex ratio from 1 to 128. (POR = 7FH)
	0	1	0	-	Multiplex Ratio							
7. Set Entire Display OFF/ON	0	1	0	1	0	1	0	0	1	0	D	Selects normal display (0) or Entire Display ON (1). (POR = A4H)
8. Set Normal/ Reverse Display	0	1	0	1	0	1	0	0	1	1	D	Normal indication (0) when low, but reverse indication (1) when high. (POR = A6H)
9. Set display offset	0	1	0	1	1	0	1	0	0	1	1	This is a double byte command that specifies the mapping of display start line to one of COM0 -127. (POR = 00H)
	0	1	0	-	COMx							
10. DC-DC Control Mode Set DC-DC Setting Mode Set	0	1	0	1	0	1	0	1	1	0	1	This command is to control the DC-DC voltage DC-DC will be turned on when display on converter (1) or DC-DC OFF (0). (POR = 81H)
	0	1	0	1	0	0	0	F2	F1	F0	D	

Command	Code											Function
	A0	\overline{RD}	\overline{WR}	D7	D6	D5	D4	D3	D2	D1	D0	
11. Display OFF/ON	0	1	0	1	0	1	0	1	1	1	D	Turns on OLED panel (1) or turns off (0). (POR = AEH)
12. Set Page Address	0	1	0	1	0	1	1	Page Address				Specifies page address to load display RAM data to page address register. (POR = B0H)
13 Set Common Output Scan Direction	0	1	0	1	1	0	0	D	*	*	*	Scan from COM0 to COM [N - 1] (0) or Scan from COM [N - 1] to COM0 (1). (POR = C0H)
14. Set Display Divide Ratio/Oscillator Frequency Mode Set	0	1	0	1	1	0	1	0	1	0	1	This command is used to set the frequency of the internal display clocks. (POR = 50H)
Divide Ratio/Oscillator Frequency Data Set	0	1	0	Oscillator Frequency				Divide Ratio				
15. Dis-charge / Pre-charge Period Mode Set	0	1	0	1	1	0	1	1	0	0	1	This command is used to set the duration of the dis-charge and pre-charge period. (POR = 22H)
Dis-charge /Pre-charge Period Data Set	0	1	0	Dis-charge Period				Pre-charge Period				
16. VCOM Deselect Level Mode Set	0	1	0	1	1	0	1	1	0	1	1	This command is to set the common pad output voltage level at deselect stage. (POR = 35H)
VCOM Deselect Level Data Set	0	1	0	VCOM = ($\beta_1 \times V_{REF}$)								
17. Set Display Start Line	0	1	0	1	1	0	1	1	1	0	0	Specify RAM display line for COM0.
	0	1	0	-	Start line							
18. Read-Modify-Write	0	1	0	1	1	1	0	0	0	0	0	Read-Modify-Write start.
19. End	0	1	0	1	1	1	0	1	1	1	0	Read-Modify-Write end.
20. NOP	0	1	0	1	1	1	0	0	0	1	1	Non-Operation Command
21 Write Display Data	1	1	0	Write RAM data								
22 Read ID	0	0	1	BUSY	ON/OFF	ID						
23. Read Display Data	1	0	1	Read RAM data								

Note: *Do not use any other commands, or the system malfunction may result.

*When the display OFF command(AEH) is executed, power saver mode(**Sleep mode**) will be entered. This mode stops every operation of the OLED display system, and can reduce current consumption nearly to a static current value if no access is made from the microprocessor. The internal status in the sleep mode is as follows:

- 1) Stops the oscillator circuit
- 2) Stops the OLED drive and outputs Hz as the segment/common driver output.
- 3) Holds the display data and operation mode provided before the start of the sleep mode.
- 4) The MPU can access to the built-in display RAM.

■ INITIALIZATION CODE

```
void Init_SH1107G(void)
{
    Write_Command(0xAE);           // Display OFF

    Write_Command(0xA8);           // Set Multiplex Ration
    Write_Command(0x7F);

    Write_Command(0xD5);           // Set Frame Frequency
    Write_Command(0x50);

    Write_Command(0xC0);           // Set Common scan direction

    Write_Command(0xD3);           // Set Display Offset
    Write_Command(0x00);

    Write_Command(0xDC);           // Set Display Start Line
    Write_Command(0x00);

    Write_Command(0x20);           // Set Page Addressing Mode

    Write_Command(0x81);           // Set Contrast Control
    Write_Command(CONTRAST);

    Write_Command(0xA0);           // Set Segment Re-map

    Write_Command(0xA4);           // Set Entire Display OFF/ON

    Write_Command(0xA6);           // Set Normal/Reverse Display
    Write_Command(0xAD);           // Set External VPP
    Write_Command(0x80);

    Write_Command(0xD9);           // Set Phase Legth
    Write_Command(0x25);

    Write_Command(0xDB);           // Set VCOMH Voltage
    Write_Command(0x30);

    Write_Command(0xAF);           //Display ON
}
```

■ SCHEMATIC EXAMPLE

◆ 8080 Series Interface Application Circuit:

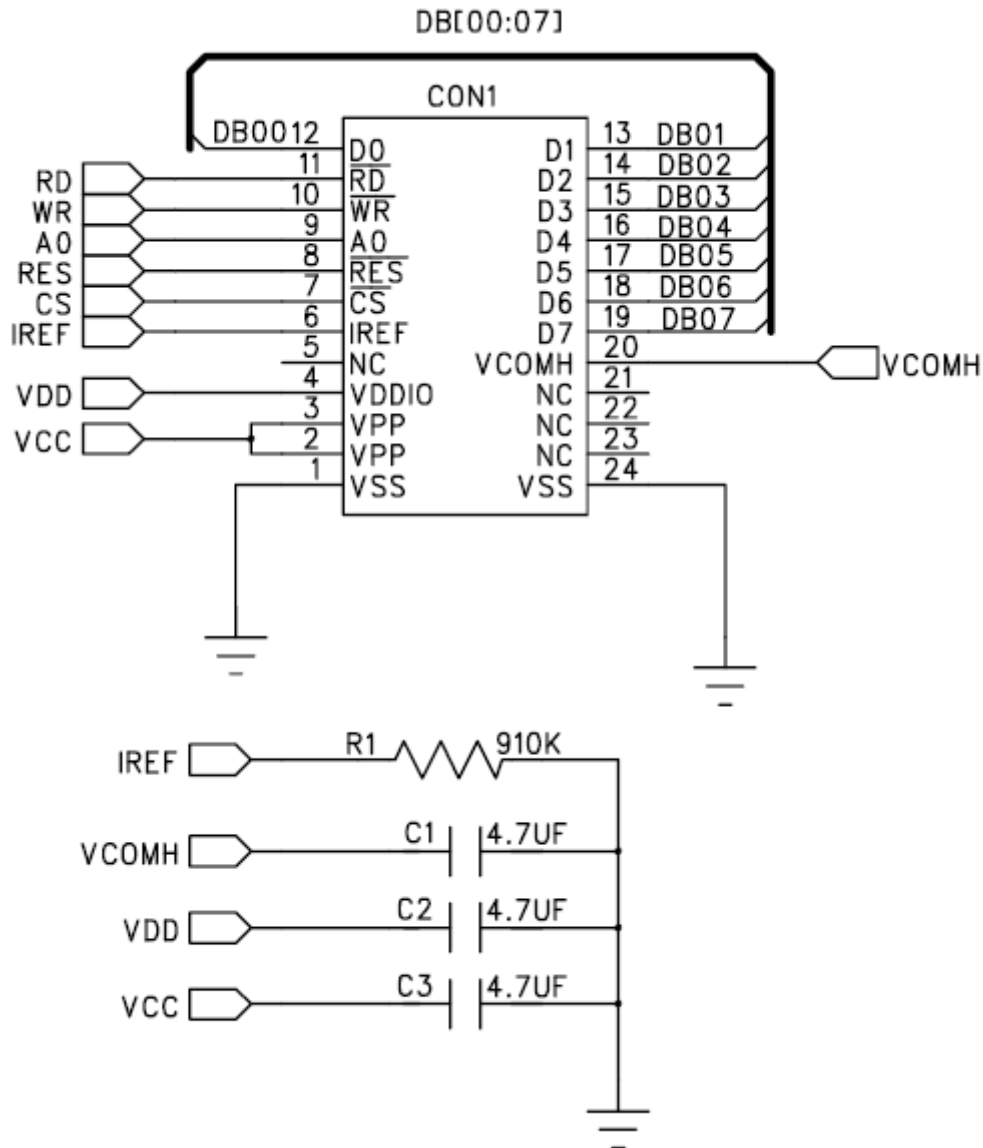

NOTE:

1. The VCOMH capacitor is recommended to use tantalum capacitor to reduce noise.
2. The capacitor and the resistor value are recommended value. Select the appropriate value against module application.

■ RELIABILITY TESTS

Item		Condition	Criterion
High Temperature Storage (HTS)		80±2°C, 200 hours	1. After testing, the function test is ok. 2. After testing, no addition to the defect. 3. After testing, the change of luminance should be within +/- 50% of initial value. 4. After testing, the change for the mono and area color must be within (+/-0.02, +/-0.02) and for the full color it must be within (+/-0.04, +/-0.04) of initial value based on 1931 CIE coordinates. 5. After testing, the change of total current consumption should be within +/- 50% of initial value.
High Temperature Operating (HTO)		70±2°C, 96 hours	
Low Temperature Storage (LTS)		-40±2°C, 200 hours	
Low Temperature Operating (LTO)		-40±2°C, 96 hours	
High Temperature / High Humidity Storage (HTHHS)		50±3°C, 90%±3%RH, 120 hours	
Thermal Shock (Non-operation) (TS)		-40±2°C ~ 25°C ~ 70±2°C (30min) (5min) (30min) 10cycles	
Vibration (Packing)	10~55~10Hz, amplitude 1.5mm, 1 hour for each direction x, y, z	1. One box for each test. 2. No addition to the cosmetic and the electrical defects.	
Drop (Packing)	Height : 1 m, each time for 6 sides, 3 edges, 1 angle		
ESD (finished product housing)	±4kV (R: 330Ω C: 150pF, 10times, air discharge)		1. After testing, cosmetic and electrical defects should not happen. 2. In case of malfunction or defect caused by ESD damage, it would be judged as a good part if it would be recovered to normal state after resetting.

- Note:**
- 1) For each reliability test, the sample quantity is 3, and only for one test item.
 - 2) The HTHHS test is requested the Pure Water(Resistance>10MΩ).
 - 3) The test should be done after 2 hours of recovery time in normal environment.

■ OUTGOING QUALITY CONTROL SPECIFICATION

◆ Standard

According to GB/T2828.1-2003/ISO 2859-1: 1999 and ANSI/ASQC Z1.4-1993, General Inspection Level II.

◆ Definition

- 1 Major defect : The defect that greatly affect the usability of product.
- 2 Minor defect : The other defects, such as cosmetic defects, etc.
- 3 Definition of inspection zone:

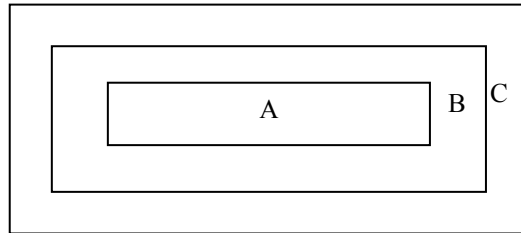

Zone A: Active Area

Zone B: Viewing Area except Zone A

Zone C: Outside Viewing Area

Note: As a general rule, visual defects in Zone C are permissible, when it is no trouble of quality and assembly to customer's product.

◆ Inspection Methods

- 1 The general inspection : under 20W x 2 or 40W fluorescent light, about 30cm viewing distance, within 45° viewing angle, under 25±5°C.

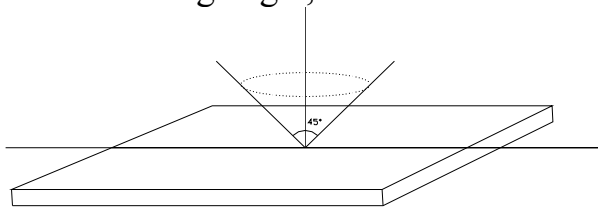

- 2 The luminance and color coordinate inspection : By PR705 or BM-7 or the equal equipments, in the dark room, under 25±5°C.

◆ Inspection Criteria

- 1 Major defect : AQL= 0.65

Item	Criterion
Function Defect	1. No display or abnormal display is not accepted
	2. Open or short is not accepted.
	3. Power consumption exceeding the spec is not accepted.
Outline Dimension	Outline dimension exceeding the spec is not accepted.
Glass Crack	Glass crack tends to enlarge is not accepted.

- 2 Minor Defect : AQL= 1.5

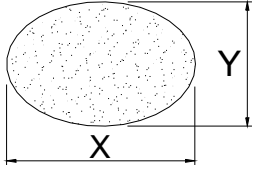
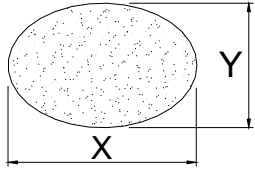
Item	Criterion			
Spot Defect (dimming and lighting spot)	Size (mm)		Accepted Qty	
			Area A + Area B	Area C
		$\Phi \leq 0.07$	Ignored	
		$0.07 < \Phi \leq 0.10$	3	Ignored
		$0.10 < \Phi \leq 0.15$	1	
$0.15 < \Phi$		0		
Note : $\Phi = (x + y) / 2$				
Line Defect (dimming and lighting line)	L (Length) : mm	W (Width) : mm	Area A + Area B	Area C
	/	$W \leq 0.02$	Ignored	
	$L \leq 3.0$	$0.02 < W \leq 0.03$	2	Ignored
	$L \leq 2.0$	$0.03 < W \leq 0.05$	1	
	/	$0.05 < W$	As spot defect	
Remarks: The total of spot defect and line defect shall not exceed 4 pcs. The distance between two lines defects must exceed 1 mm				
Polarizer Stain	Stain which can be wiped off lightly with a soft cloth or similar cleaning is accepted, otherwise, according to the Spot Defect and the Line Defect.			
Polarizer Scratch	1. If scratch can be seen during operation, according to the criterions of the Spot Defect and the Line Defect.			
	2. If scratch can be seen only under non-operation or some special angle, the criterion is as below :			
	L (Length) : mm	W (Width) : mm	Area A + Area B	Area C
	/	$W \leq 0.02$	Ignore	
	$3.0 < L \leq 5.0$	$0.02 < W \leq 0.04$	2	Ignore
	$L \leq 3.0$	$0.04 < W \leq 0.06$	1	
/	$0.06 < W$	0		
Polarizer Air Bubble	Size		Area A + Area B	Area C
		$\Phi \leq 0.20$	Ignored	
		$0.20 < \Phi \leq 0.30$	2	Ignored
		$0.30 < \Phi \leq 0.50$	1	
		$0.50 < \Phi$	0	

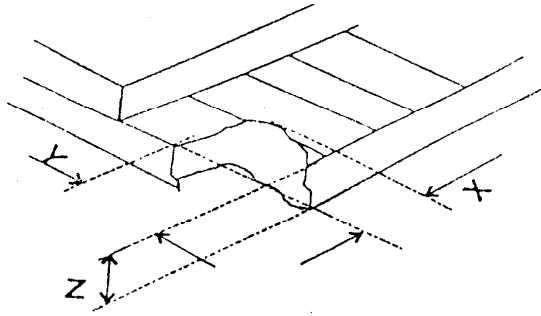
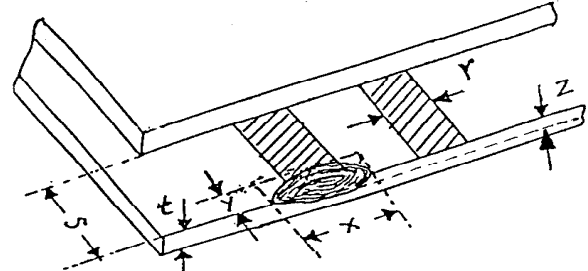
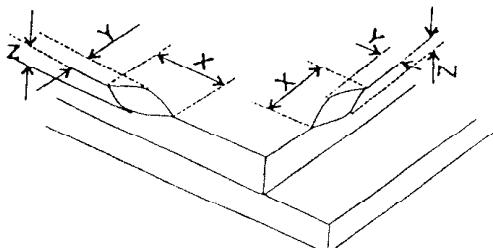
Glass Defect (Glass Chipped)	1. On the corner  <table border="1" style="margin-left: 20px;"> <thead> <tr> <th colspan="2">(mm)</th> </tr> </thead> <tbody> <tr> <td>x</td> <td>≤ 1.5</td> </tr> <tr> <td>y</td> <td>≤ 1.5</td> </tr> <tr> <td>z</td> <td>$\leq t$</td> </tr> </tbody> </table>	(mm)		x	≤ 1.5	y	≤ 1.5	z	$\leq t$
	(mm)								
	x	≤ 1.5							
y	≤ 1.5								
z	$\leq t$								
2. On the bonding edge  <table border="1" style="margin-left: 20px;"> <thead> <tr> <th colspan="2">(mm)</th> </tr> </thead> <tbody> <tr> <td>x</td> <td>$\leq a / 4$</td> </tr> <tr> <td>y</td> <td>$\leq s / 3 \ \& \ \leq 0.7$</td> </tr> <tr> <td>z</td> <td>$\leq t$</td> </tr> </tbody> </table>	(mm)		x	$\leq a / 4$	y	$\leq s / 3 \ \& \ \leq 0.7$	z	$\leq t$	
(mm)									
x	$\leq a / 4$								
y	$\leq s / 3 \ \& \ \leq 0.7$								
z	$\leq t$								
3. On the other edges  <table border="1" style="margin-left: 20px;"> <thead> <tr> <th colspan="2">(mm)</th> </tr> </thead> <tbody> <tr> <td>x</td> <td>$\leq a / 8$</td> </tr> <tr> <td>y</td> <td>≤ 0.7</td> </tr> <tr> <td>z</td> <td>$\leq t$</td> </tr> </tbody> </table>	(mm)		x	$\leq a / 8$	y	≤ 0.7	z	$\leq t$	
(mm)									
x	$\leq a / 8$								
y	≤ 0.7								
z	$\leq t$								
Note: t: glass thickness ; s: pad width ; a: the length of the edge									
TCP Defect	Crack, deep fold and deep pressure mark on the TCP are not accepted								
Pixel Size	The tolerance of display pixel dimension should be within $\pm 20\%$ of the spec								
Luminance	Refer to the spec or the reference sample								
Color	Refer to the spec or the reference sample								

■ CAUTIONS IN USING OLED MODULE

◆ Precautions For Handling OLED Module:

1. OLED module consists of glass and polarizer. Pay attention to the following items when handling:
 - i. Avoid drop from high, avoid excessive impact and pressure.
 - ii. Do not touch, push or rub the exposed polarizers with anything harder than an HB pencil lead.
 - iii. If the surface becomes dirty, breathe on the surface and gently wipe it off with a soft dry cloth. If it is terrible dirty, moisten the soft cloth with Isopropyl alcohol or Ethyl alcohol. Other solvents may damage the polarizer. Especially water, Ketone and Aromatic solvents.
 - iv. Wipe off saliva or water drops immediately, contact the polarizer with water over a long period of time may cause deformation.
 - v. Please keep the temperature within specified range for use and storage. Polarization degradation, bubble generation or polarizer peeling-off may occur with high temperature and high humidity.
 - vi. Condensation on the surface and the terminals due to cold or anything will damage, stain or dirty the polarizer, so make it clean as the way of iii.
2. Do not attempt to disassemble or process the OLED Module.
3. Make sure the TCP or the FPC of the Module is free of twisting, warping and distortion, do not pull or bend them forcefully, especially the soldering pins. On the other side, the SLIT part of the TCP is made to bend in the necessary case.
4. When assembling the module into other equipment, give the glass enough space to avoid excessive pressure on the glass, especially the glass cover which is much more fragile.
5. Be sure to keep the air pressure under 120 kPa, otherwise the glass cover is to be cracked.
6. Be careful to prevent damage by static electricity:
 - i. Be sure to ground the body when handling the OLED Modules.
 - ii. All machines and tools required for assembling, such as soldering irons, must be properly grounded.
 - iii. Do not assemble and do no other work under dry conditions to reduce the amount of static electricity generated. A relative humidity of 50%-60% is recommended.
 - iv. Peel off the protective film slowly to avoid the amount of static electricity generated.
 - v. Avoid to touch the circuit, the soldering pins and the IC on the Module by the body.
 - vi. Be sure to use anti-static package.
7. Contamination on terminals can cause an electrochemical reaction and corrode the terminal circuit, so make it clean anytime.
8. All terminals should be open, do not attach any conductor or semiconductor on the terminals.
9. When the logic circuit power is off, do not apply the input signals.
10. Power on sequence: $V_{DD} \rightarrow V_{CC}$, and power off sequence: $V_{CC} \rightarrow V_{DD}$.
11. Be sure to keep temperature, humidity and voltage within the ranges of the spec, otherwise shorten Module's life time, even make it damaged.
12. Be sure to drive the OLED Module following the Specification and datasheet of IC controller, otherwise something wrong may be seen.

13. When displaying images, keep them rolling, and avoid one fixed image displaying more than 30 seconds, otherwise the residue image is to be seen. This is the speciality of OLED.

◆ **Precautions For Soldering OLED Module:**

1. Soldering temperature : $260^{\circ}\text{C} \pm 10^{\circ}\text{C}$.
2. Soldering time : 3-4 sec.
3. Repeating time : no more than 3 times.
4. If soldering flux is used, be sure to remove any remaining flux after finishing soldering operation. (This does not apply in the case of a non-halogen type of flux.) It is recommended to protect the surface with a cover during soldering to prevent any damage due to flux spatters.

◆ **Precautions For Storing OLED Module:**

1. Be sure to store the OLED Module in the vacuum bag with dessicant.
2. If the Module can not be used up in 1 month after the bag being opened, make sure to seal the Module in the vacuum bag with dessicant again.
3. Store the Module in a dark place, do not expose to sunlight or fluorescent light.
4. The polarizer surface should not touch any other objects. It is recommended to store the Module in the shipping container.
5. It is recommended to keep the temperature between 0°C and 30°C , the relative humidity not over 60%.

◆ **Limited Warranty**

Unless relevant quality agreements signed with customer and law enforcement, for a period of 12 months from date of production, all products (except automotive products) Li Yuan will replace or repair any of its OLED modules which are found to be functional defect when inspected in accordance with Li Yuan OLED acceptance standards (copies available upon request). Cosmetic/visual defects must be returned to Li Yuan within 90 days of shipment. Confirmation of such date should be based on freight documents. The warranty liability of Li Yuan is limited to repair and/or replacement on the terms above. Li Yuan will not be responsible for any subsequent or consequential events.

◆ **Return OLED Module Under Warranty:**

1. No warranty in the case that the precautions are disregarded.
2. Module repairs will be invoiced to the customer upon mutual agreement. Modules must be returned with sufficient description of the failures or defects.

◆ **PRIOR CONSULT MATTER**

1. For Li Yuan standard products , we keep the right to change material ,process ... for improving the product property without any notice on our customer.
2. If you have special requirement about reliability condition, please let us know before you start the test on our samples.