

TAIL LENGTHS

- 2.67 ± 0.25 FOR 1.60 (.063") THK PCB
- 3.18 ± 0.25 FOR 2.36 (.093") THK PCB
- 4.00 ± 0.25 FOR 3.18 (.125") THK PCB

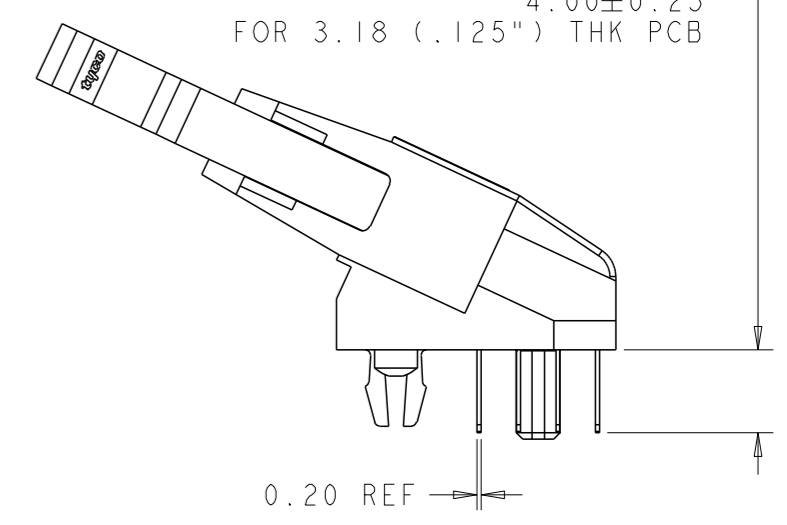
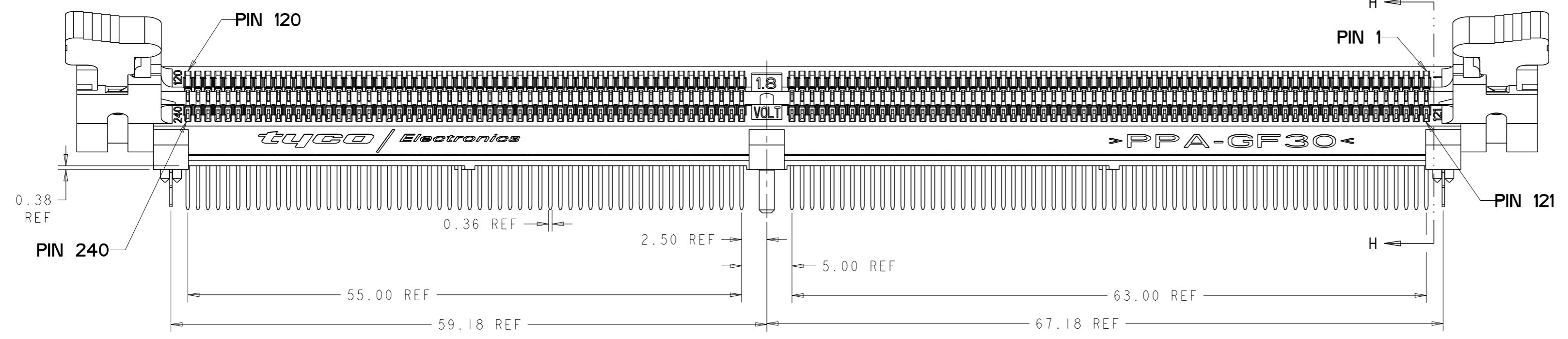

- 1 MATERIALS:
 HOUSING: HIGH TEMPERATURE THERMOPLASTIC, UL94 V-0
 EXTRACTOR: HIGH TEMPERATURE THERMOPLASTIC
 CONTACTS: COPPER ALLOY
 RETENTION BARB: COPPER ALLOY

- 6 DATUM -F- IS CONNECTOR SIDE SURFACE OF PCB.
 7 PORE BLOCKER APPLIED TO CONTACT INTERFACE.

- 2 INTERFACE FINISH:
 0.00076 MIN THK GOLD OVER 0.00127 MIN THK NICKEL.
 0.00038 MIN THK GOLD OVER 0.00127 MIN THK NICKEL.
- 3 SOLDER TAIL FINISH:
 0.00300 MIN THK MATTE LEAD FREE PLATING OVER 0.00127 MIN THK NICKEL.
- 4 RIGHT HOLE IS GLOBAL D-E ORIGIN FOR ALL POSITIONAL TOLERANCES.
 LEFT AND RIGHT NON-PLATED THRU HOLES ESTABLISH -E-.
- 5 FINISHED HOLE SIZE. Ø0.15 MAXIMUM ANNULAR RING.

DIMENSIONS:		TOLERANCES UNLESS OTHERWISE SPECIFIED:		DWG: D. RINGLER 18JUL2003		Tyco Electronics Corporation	
mm		0 PLC ±.25		CHK: J. McCLELLAN 21AUG2003		SH/CN GuiPing RD 6688	
1 PLC ±0.25		2 PLC ±0.15		APVD: -		NAME: SOCKET ASSEMBLY	
2 PLC ±0.15		3 PLC ±0.013		PRODUCT SPEC: 108-2168		25 DEGREE DDR 11 DIMM	
3 PLC ±0.013		4 PLC ±.1		APPLICATION SPEC: 114-13130		240 POSITION	
4 PLC ±.1		ANGLES ±.1		SIZE: A		CAGE CODE: 00779	
MATERIAL: 1		FINISH: 2, 3		DRAWING NO: C=1658787		RESTRICTED TO: -	
1		2, 3		WEIGHT: -		SCALE: 1:1	
CUSTOMER DRAWING		SCALE: 1:1		SHEET 1 OF 3		REV D	

LOC		DIST		REVISIONS			
P	LTN	DESCRIPTION	DATE	DRN	APVD		
ES	00	SEE SHEET 1					

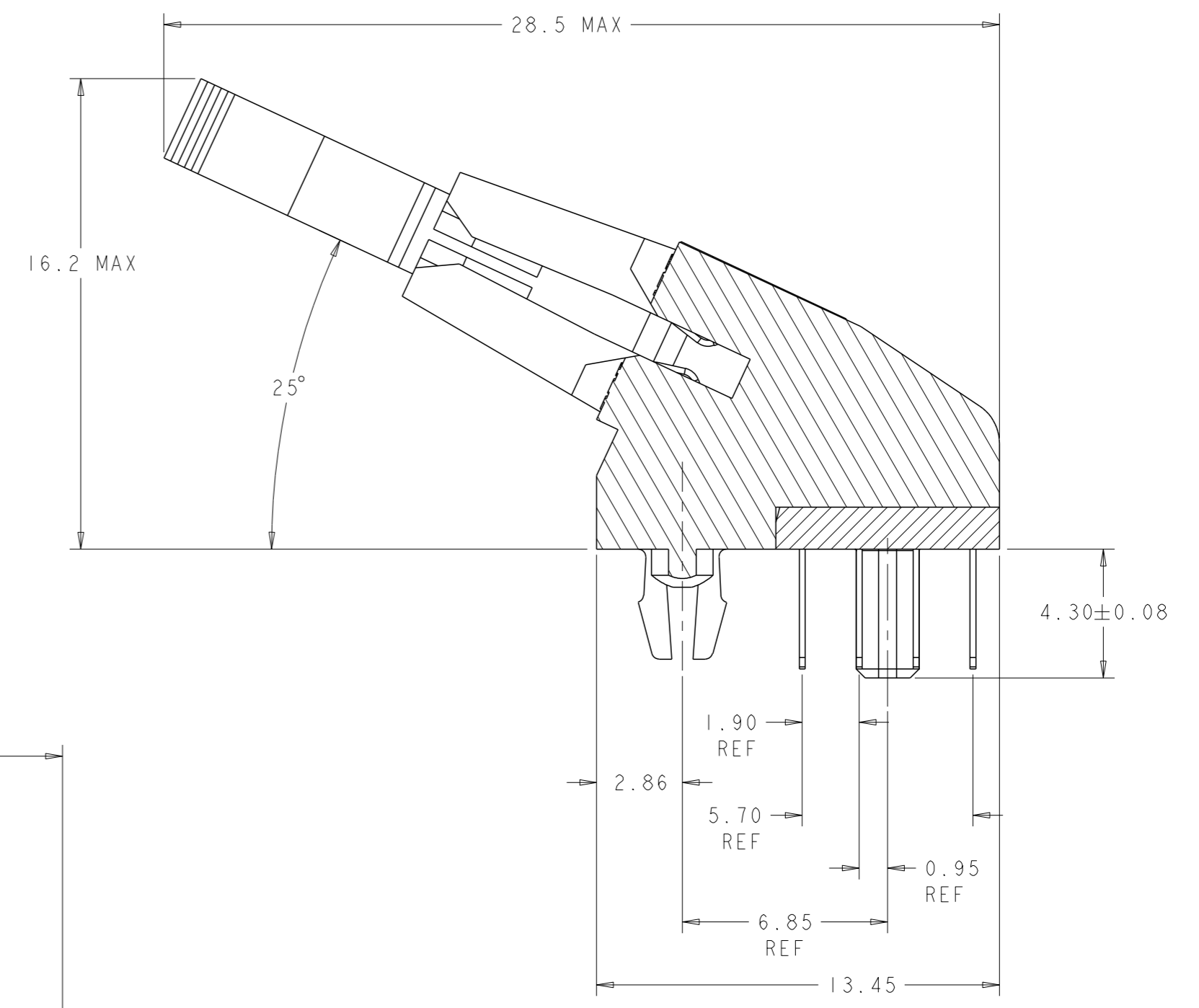

SECTION H-H
SCALE 8:1

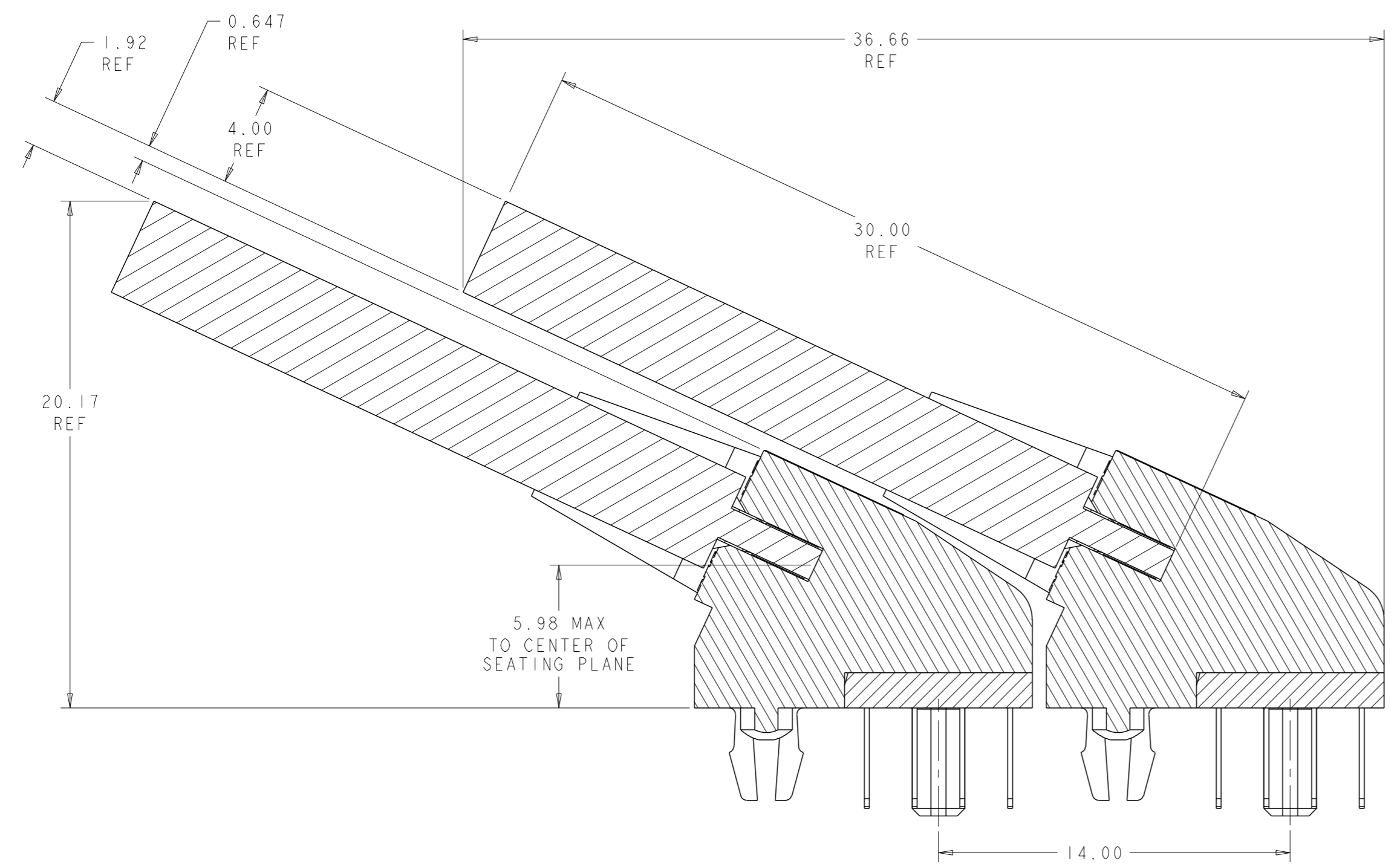

MINIMUM RECOMMENDED ROW TO ROW SPACING
FOR 4mm THICK MODULE

SCALE 8:1

①	OBsolete	EXTRATOR COLOR	HOUSING COLOR	CONTACT GOLD INTERFACE	TAIL LENGTH	PART NUMBER
	OBsolete	BLACK	BLACK	0.00038 MIN Δ	2.67	2-1658787-4
	OBsolete			0.00008 MIN Δ	4.00	1658787-9
	OBsolete			0.00008 MIN Δ	3.18	1658787-8
	OBsolete			0.00008 MIN Δ	2.67	1658787-7
	OBsolete			0.00038 MIN Δ	4.00	1658787-6
	OBsolete	NATURAL	BLACK	0.00038 MIN Δ	3.18	1658787-5
	OBsolete			0.00038 MIN Δ	2.67	1658787-4
				0.00076 MIN Δ	4.00	1658787-3
	OBsolete			0.00076 MIN Δ	3.18	1658787-2
	OBsolete			0.00076 MIN Δ	2.67	1658787-1

DIMENSIONS:		TOLERANCES UNLESS OTHERWISE SPECIFIED:		DWN D. RINGLER 18JUL2003		Tyco Electronics corporation	
mm		0 PLC ±.25		CHK 21AUG2003		SH/CN GuiPing RD 6688	
①		1 PLC ±0.25		APVD -		NAME	
		2 PLC ±0.15		PRODUCT SPEC		SOCKET ASSEMBLY	
		3 PLC ±0.013		APPLICATION SPEC		25 DEGREE DDR 11 DIMM	
		4 PLC ±.1		MATERIAL		240 POSITION	
		FINISH		WEIGHT		SIZE CAGE CODE DRAWING NO RESTRICTED TO	
				CUSTOMER DRAWING		A 00779 C=1658787	
				SCALE 1:1		SHEET 2 OF 3 REV D	

LOC	DIST	REV	DATE	BY	APPV
ES	00				

REVISIONS		DATE	BY	APPV
1	SEE SHEET 1			

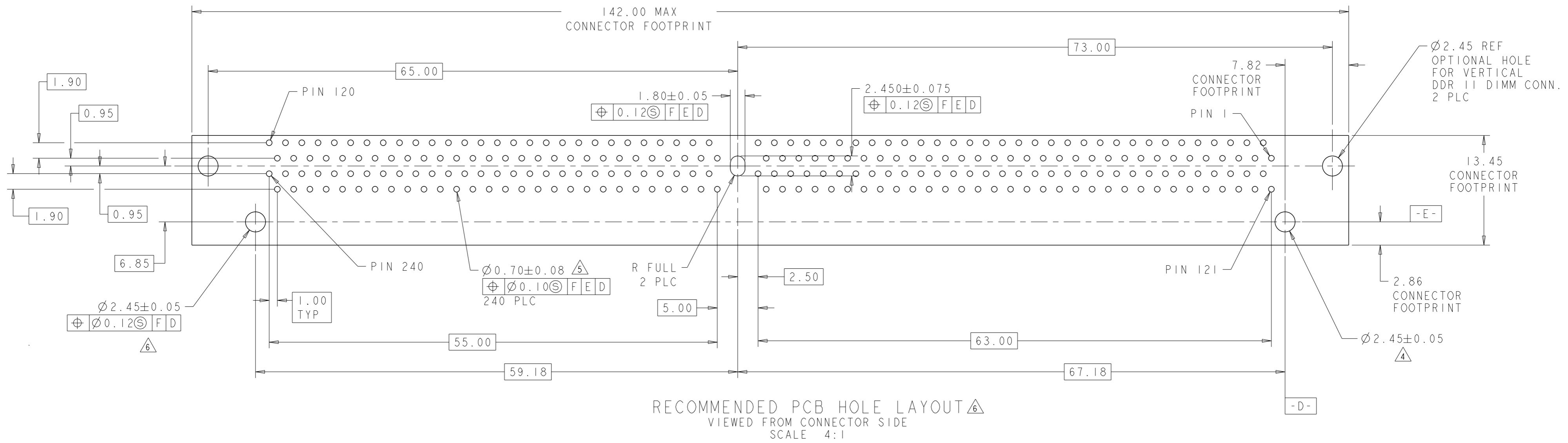

RECOMMENDED PCB HOLE LAYOUT
VIEWED FROM CONNECTOR SIDE
SCALE 4:1

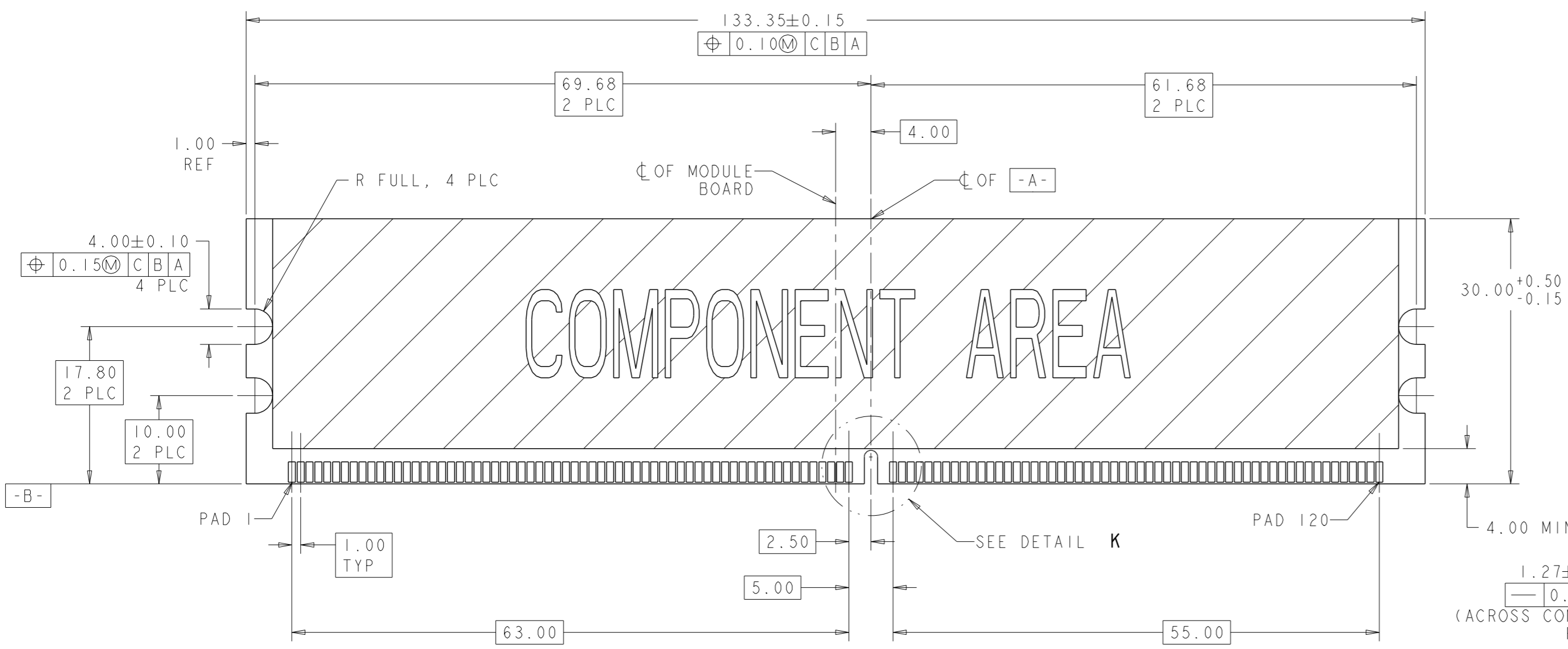

RECOMMENDED MODULE LAYOUT
SCALE 3:1

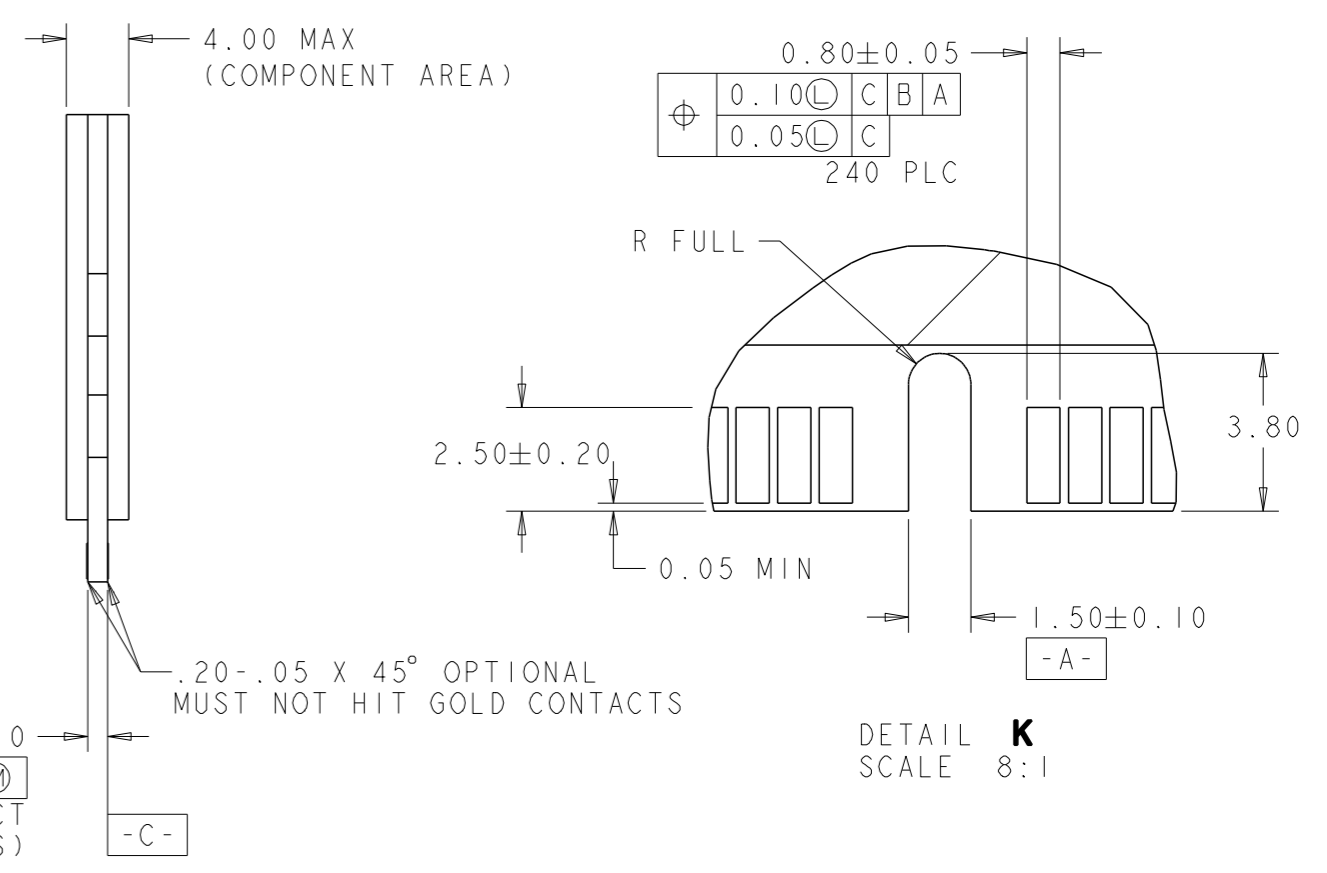

DETAIL K
SCALE 8:1

<small>THIS DRAWING IS A CONTROLLED DOCUMENT FOR TYCO ELECTRONICS CORPORATION. IT IS BRANDED TO CONTROL AND THE CONTROL LABELING ORGANIZATION SHOULD BE CONTACTED FOR THE LATEST REVISION.</small>		DWN: D. RINGLER 18JUL2003 CHK: 21AUG2003 APVD: - PRODUCT SPEC: - APPLICATION SPEC: - MATERIAL: - FINISH: -	Tyco Electronics Corporation Tyco Electronics Corporation SH/CN GuiPing RD 668#
DIMENSIONS: mm TOLERANCES UNLESS OTHERWISE SPECIFIED: 0 PLC ±.25 1 PLC ±0.25 2 PLC ±0.15 3 PLC ±0.013 4 PLC ±. ANGLES ±1	NAME: SOCKET ASSEMBLY 25 DEGREE DDR 11 DIMM 240 POSITION	SIZE: A CAGE CODE: 00779 DRAWING NO: C=1658787	RESTRICTED TO: - SCALE: 1:1 SHEET: 3 OF 3 REV: D