

HDSP-815E/816E/815G/816G

20-mm (0.8-inch) General-Purpose Seven-Segment Displays



Description

These Broadcom® 20-mm (0.8-inch) displays use industry-standard size and pinout. The devices are available as either common anode or common cathode. These gray-faced displays are available in either red or green colors and are suitable for indoor use.

No color binning is offered for these parts.

Applications

- Suitable for indoor use
- Not recommended for industrial applications
- Extreme temperature cycling not recommended

Features

- Industry-standard size
- Industry-standard pinout 15.24-mm (0.6-in.) DIP leads on 2.54-mm (0.1-in.) centers
- Choice of colors
 - Red, Green
- Excellent appearance
 - Mitered font
 - Mitered corners on segments
 - Gray face paint
 - Gray package gives optimum contrast
 - ±50° viewing angle
- Design flexibility
 - Common anode or common cathode
- Categorized for luminous intensity

Devices

AllnGaP Red	AllnGaP Green	Description
HDSP-815E	HDSP-815G	Common Anode Right Hand Decimal
HDSP-816E	HDSP-816G	Common Cathode Right Hand Decimal

Package Dimensions

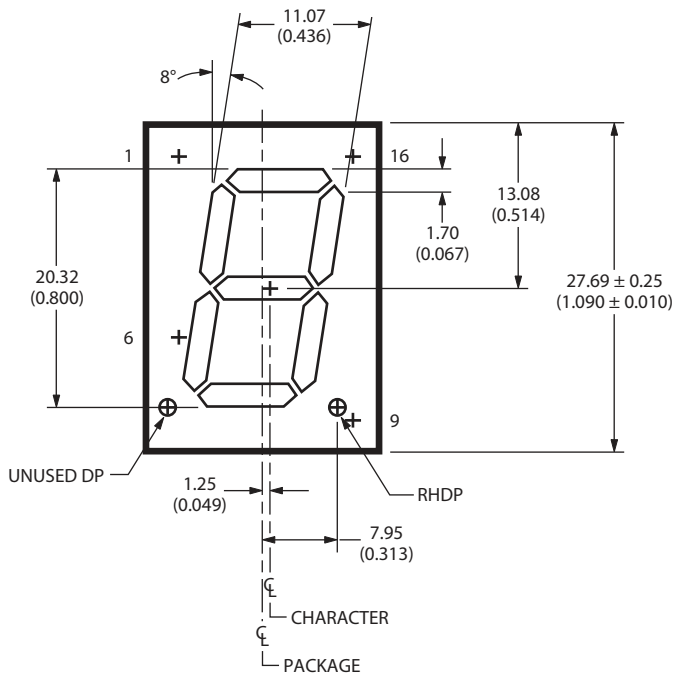

FRONT VIEW

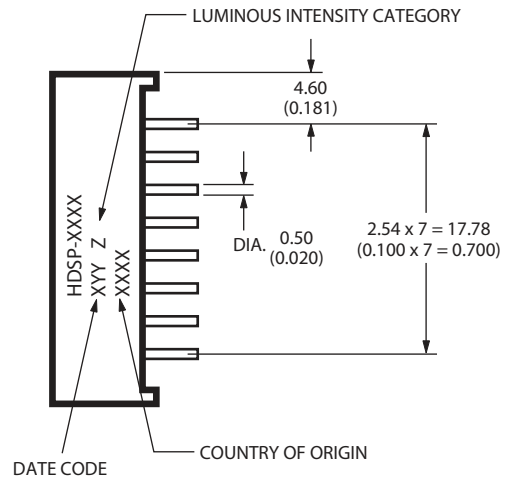

SIDE VIEW

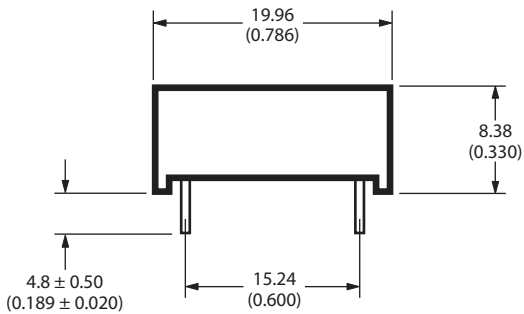

END VIEW

NOTES:

1. DIMENSIONS IN MILLIMETERS AND (INCHES).
2. TOLERANCE IS 0.25 mm (0.010 INCH) UNLESS OTHERWISE STATED.

Internal Circuit Diagram

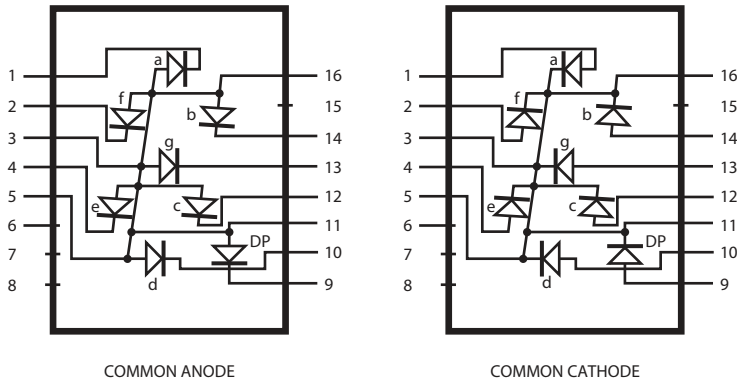

COMMON ANODE		COMMON CATHODE	
PIN	FUNCTION	PIN	FUNCTION
1	CATHODE A	1	ANODE A
2	CATHODE F	2	ANODE F
3	COMMON ANODE	3	COMMON CATHODE
4	CATHODE E	4	ANODE E
5	COMMON ANODE	5	COMMON CATHODE
6	NO CONNECTION	6	NO CONNECTION
7	NO PIN	7	NO PIN
8	NO PIN	8	NO PIN
9	CATHODE RHDP	9	ANODE RHDP
10	CATHODE D	10	ANODE D
11	COMMON ANODE	11	COMMON CATHODE
12	CATHODE C	12	ANODE C
13	CATHODE G	13	ANODE G
14	CATHODE B	14	ANODE B
15	NO PIN	15	NO PIN
16	COMMON ANODE	16	COMMON CATHODE

Absolute Maximum Ratings at T_A = 25°C

Parameter	Red HDSP-815E HDSP-816E	Green HDSP-815G HDSP-816G	Unit
Power Dissipation per Segment or DP	62.5	62.5	mW
Peak Forward Current per Segment or DP ^a	90	90	mA
DC Forward Current per Segment or DP	25 ^b	25 ^c	mA
Operating Temperature Range	-40 to +85	-40 to +85	°C
Storage Temperature Range	-40 to +85	-40 to +85	°C
Reverse Voltage per Segment or DP ^d	3	3	V
Wave Soldering Temperature for 3 Seconds (1.6-mm [0.063-in.] below the body) ^e	250	250	°C

- a. Duty factor = 10%, frequency = 1 kHz, T_A = 25°C.
- b. Derate linearly as shown in [Figure 4](#).
- c. Derate linearly as shown in [Figure 8](#).
- d. Reverse Voltage is for LED testing purposes and is not recommended to be used as an application condition.
- e. Not recommended to be soldered more than 2 times. Minimum interval between solderings is 15 minutes. Total soldering time not to exceed 5 seconds.

Electrical/Optical Characteristics at $T_A = 25^\circ\text{C}$

Parameter	Symbol	Min.	Typ.	Max.	Units	Test Conditions
Red (HDSP-815E, HDSP-816E)						
Luminous Intensity/Segment (Digit Average) ^{a, b, c}	I_V	7.57	8.90	—	mcd	$I_F = 20\text{ mA}$
Forward Voltage ^d	V_F	—	1.95	2.50	V	$I_F = 20\text{ mA}$
Peak Wavelength	λ_P	—	633	—	nm	
Dominant Wavelength ^e	λ_d	—	622	—	nm	
Reverse Voltage ^f	V_R	3.0	—	—	V	$I_R = 100\ \mu\text{A}$
Green (HDSP-815G, HDSP-816G)						
Luminous Intensity/Segment (Digit Average) ^{a, b, c}	I_V	10.78	14.80	—	mcd	$I_F = 20\text{ mA}$
Forward Voltage ^d	V_F	—	2.10	2.50	V	$I_F = 20\text{ mA}$
Peak Wavelength	λ_P	—	572	—	nm	
Dominant Wavelength ^e	λ_d	—	570	—	nm	
Reverse Voltage ^f	V_R	3.0	—	—	V	$I_R = 100\ \mu\text{A}$

a. The luminous intensity, I_V , is measured at the mechanical axis of the package.

b. The optical axis is closely aligned with the mechanical axis of the package.

c. Tolerance is $\pm 15\%$.

d. Forward voltage tolerance is $\pm 0.1\text{V}$.

e. The dominant wavelength, λ_d , is derived from the CIE Chromaticity Diagram and represents the perceived color of the device.

f. Indicates product final test condition. Long term reverse bias is not recommended.

Intensity Bin Limits (mcd at 20 mA) Color Categories

Red

IV Bin Category	Min.	Max.
P	7.57	10.78
Q	10.78	15.10
R	15.10	21.58

Tolerance for each bin limit is $\pm 15\%$.

Green

IV Bin Category	Min.	Max.
Q	10.78	15.10
R	15.10	21.58
S	21.58	30.21

Tolerance for each bin limit is $\pm 15\%$.

Color	Bin	Dominant Wavelength (nm)	
		Min.	Max.
Green	1	569.00	572.00
	2	572.00	575.00

Tolerance for each bin limit is $\pm 1\text{ nm}$.

Red

Figure 1: Relative Intensity vs. Wavelength

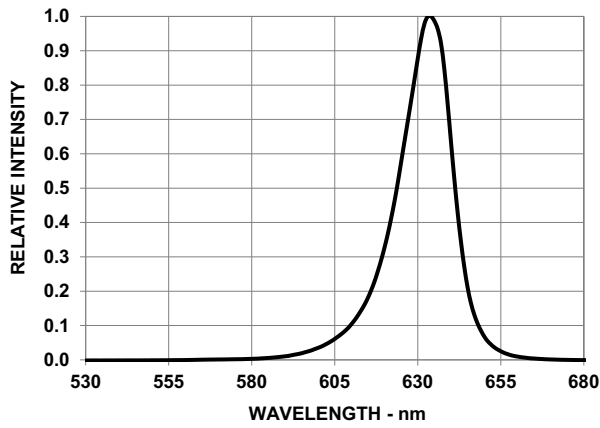

Figure 2: Forward Current vs. Forward Voltage

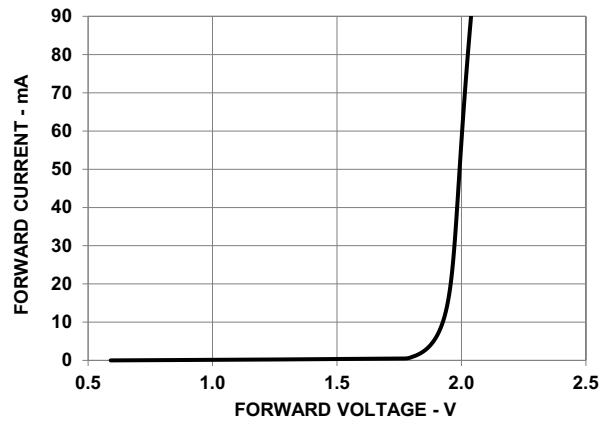

Figure 3: Relative Luminous Intensity vs. Forward Current

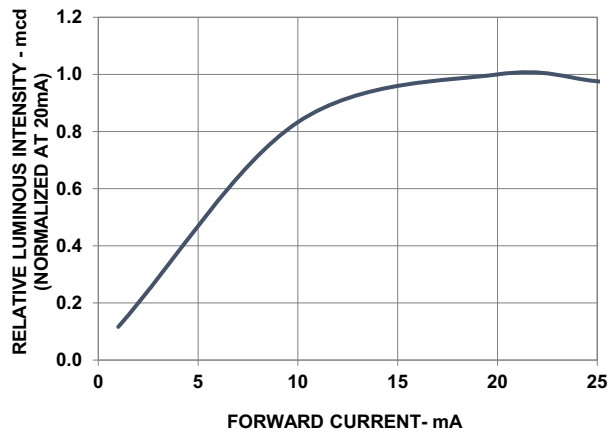
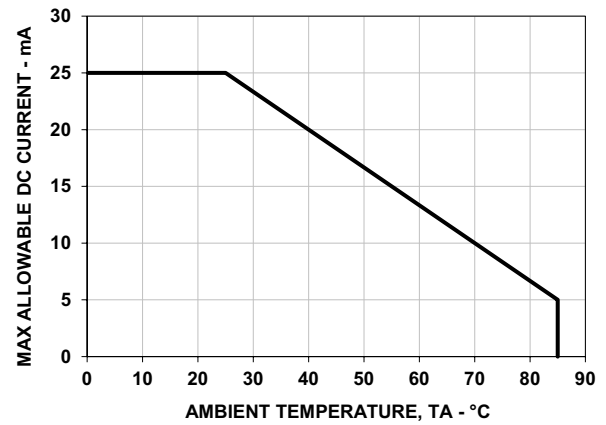

Figure 4: Maximum Forward Current vs. Ambient Temperature



Green

Figure 5: Relative Intensity vs. Wavelength

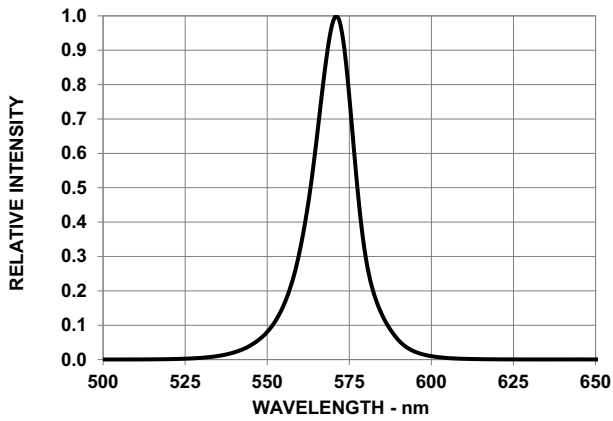

Figure 6: Forward Current vs. Forward Voltage

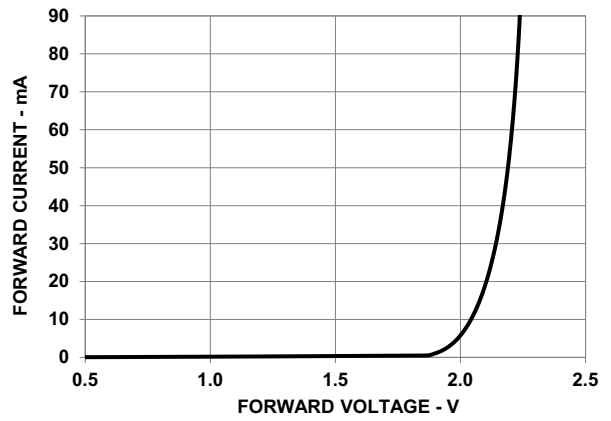

Figure 7: Relative Luminous Intensity vs. Forward Current

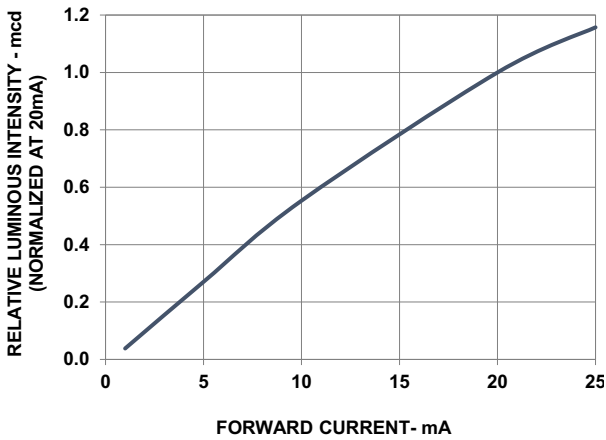
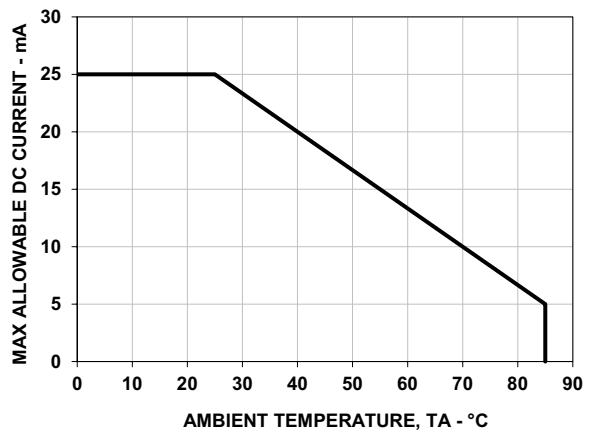

Figure 8: Maximum Forward Current vs. Ambient Temperature



Precautionary Notes

Soldering and Handling Precautions

- Set and maintain the wave soldering parameters according to the recommended temperature and dwell time. Perform daily checks on the profile to ensure that it conforms to the recommended conditions. Exceeding these conditions will over-stress the LEDs and cause premature failures.
- Use only bottom preheaters to reduce thermal stress experienced by the LEDs.
- Recalibrate the soldering profile before loading a new type of PCB. A PCB with different size and design (component density) will have different heat capacity and might cause a change in temperature experienced by the PCB if the same wave soldering setting is used.
- Do not perform wave soldering more than once.
- Any alignment fixture used during wave soldering must be loosely fitted and must not apply stress on the LEDs. Use non-metal material as it absorbs less heat during the wave soldering process.
- At elevated temperatures, the LEDs are more susceptible to mechanical stress. Allow the PCB to be sufficiently cooled to room temperature before handling. Do not apply stress to the LED when it is hot.
- Use wave soldering to solder the LED. Use hand soldering only for rework or touch up if unavoidable, but it must be strictly controlled to following conditions:
 - Soldering iron tip temperature = 315°C maximum
 - Soldering duration = 2 seconds maximum
 - Number of cycles = 1 only
 - Power of soldering iron = 50W maximum
- For ESD sensitive devices, apply proper ESD precautions at the soldering station. Use only an ESD-safe soldering iron.
- Do not touch the LED package body with the soldering iron except for the soldering terminals as it may cause damage to the LED.
- Confirm beforehand whether the functionality and performance of the LED are affected by soldering with hand soldering.
- Keep the heat source at least 1.6 mm away from the LED body during soldering.
- Design an appropriate hole size to avoid problems during insertion.
- Do not use cleaning agents from the ketone family (acetone, methyl ethylketone, and so on) and from the chlorinated hydrocarbon family (methylene chloride,

trichloroethylene, carbon tetrachloride, and so on) to clean the LED displays. All of these solvents attack or dissolve the encapsulating epoxies used to form the package of plastic LED parts.

- For the purposes of cleaning, wash with DI water only. Perform the cleaning process at room temperature only. Clear any water or moisture from the LED display immediately after washing.
- Use *No clean* solder paste for soldering.

Figure 9: Recommended Wave Soldering Profile

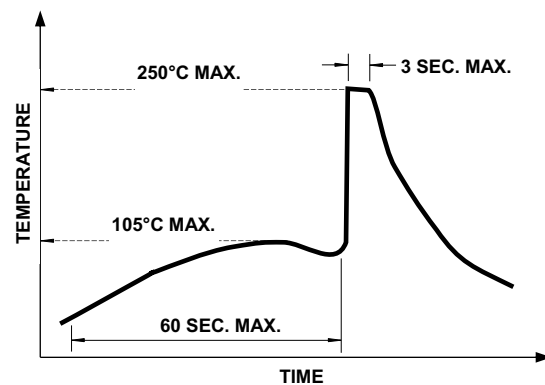

NOTE: The measurements are performed with a thermocouple mounted at the bottom of the PCB.

Application Precautions

- The drive current of the LED must not exceed the maximum allowable limit across temperature as stated in the data sheet. Use constant current driving to ensure consistent performance.
- The circuit design must cater to the entire range of forward voltage (V_F) of the LEDs to ensure the intended drive current can always be achieved.
- The LED exhibits slightly different characteristics at different drive currents, which may result in a larger variation of performance (such as intensity, wavelength, and forward voltage). Set the application current as close as possible to the test current to minimize these variations.
- The LED is not intended for reverse bias. Use other appropriate components for such purposes. When driving the LED in matrix form, ensure that the reverse bias voltage does not exceed the allowable limit of the LED.

- Avoid rapid change in ambient temperature, especially in high-humidity environments, because they cause condensation on the LED.
- If the LED is intended to be used in harsh or outdoor environment, protect the LED against damages caused by rain, water, dust, oil, corrosive gases, external mechanical stresses, and so on.

Eye Safety Precautions

LEDs may pose optical hazards when in operation. Do not look directly at operating LEDs because it might be harmful to the eyes. For safety reasons, use appropriate shielding or personal protective equipment.

Disclaimer

Broadcom's products and software are not specifically designed, manufactured, or authorized for sale as parts, components, or assemblies for the planning, construction, maintenance, or direct operation of a nuclear facility or for use in medical devices or applications. The customer is solely responsible, and waives all rights to make claims against Broadcom or its suppliers, for all loss, damage, expense, or liability in connection with such use.

Copyright © 2005–2022 Broadcom. All Rights Reserved. The term “Broadcom” refers to Broadcom Inc. and/or its subsidiaries. For more information, go to www.broadcom.com. All trademarks, trade names, service marks, and logos referenced herein belong to their respective companies.

Broadcom reserves the right to make changes without further notice to any products or data herein to improve reliability, function, or design. Information furnished by Broadcom is believed to be accurate and reliable. However, Broadcom does not assume any liability arising out of the application or use of this information, nor the application or use of any product or circuit described herein, neither does it convey any license under its patent rights nor the rights of others.



Lead (Pb) Free
RoHS Compliant