

REV	ECN	APP'D
J	5968	<i>10-4-06</i>

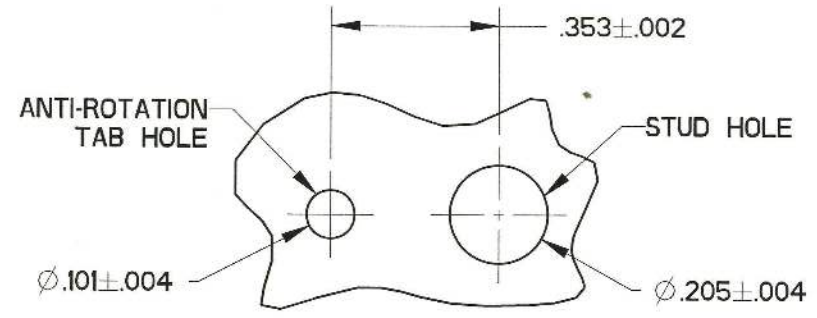

MOUNTING HOLE CONFIGURATION

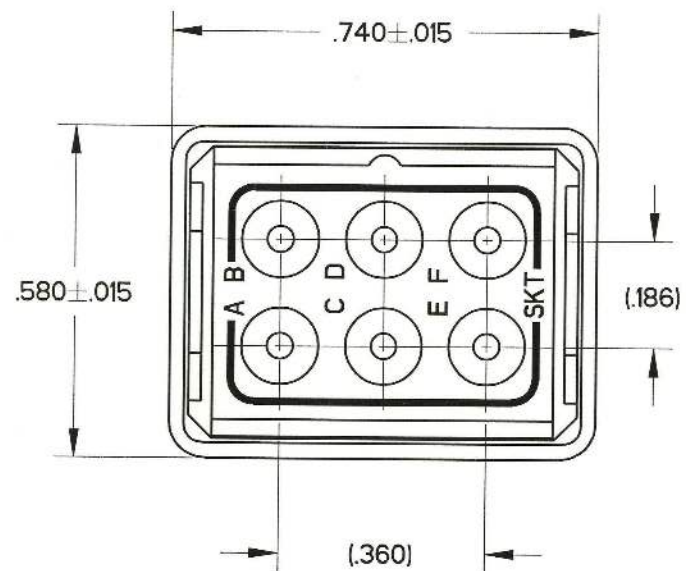
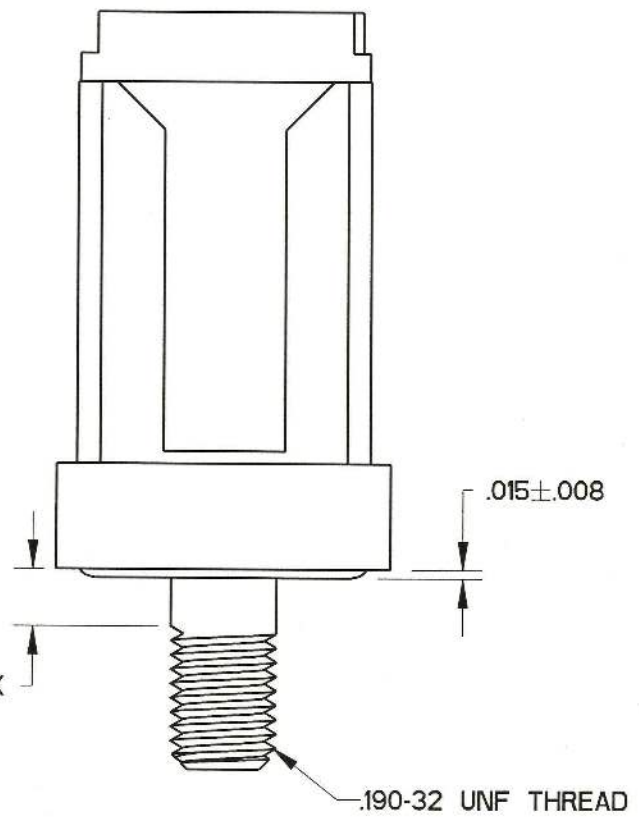
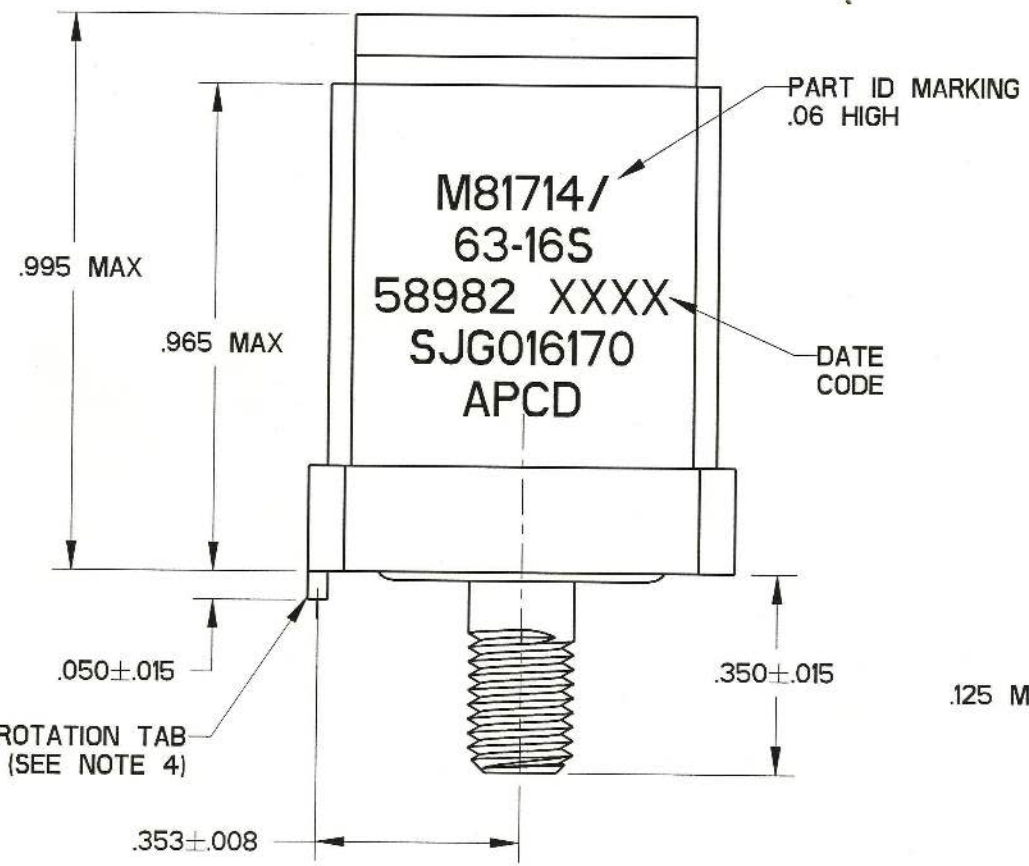
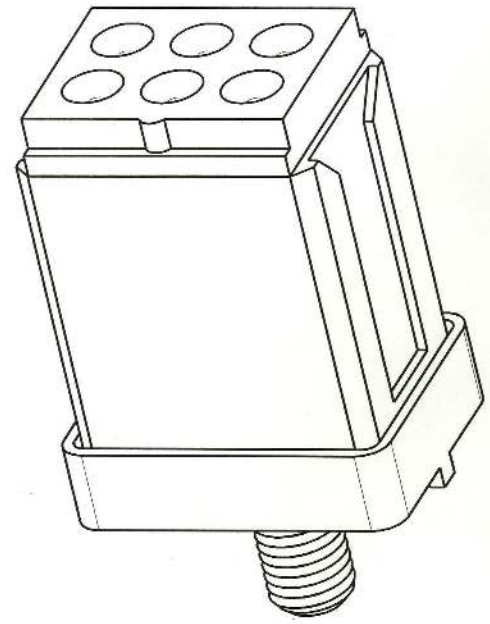

- NOTES:
- PART MEETS ALL REQUIREMENTS OF MIL-T-81714/63
 - MATERIALS:
GROMMET - SILICONE RUBBER PER A-A-59588
BODY - POLYETHERIMIDE PER ASTM-D-5205
SHELL/STUD - COPPER ALLOY, GOLD PLATED PER SAE-AMS-2422
CONTACT RETAINER CLIPS - STAINLESS STEEL PER ASTM-A666
 - PART ACCEPTS M39029/22-193 SOCKET CONTACTS. SEE TABLE

APCD P/N	SUPPLIED		MARKING APCD PART NO.
	SKTS	PLUGS	
SJG016170	7	2	SJG016170
SJG016171	-	-	

SJG316170

SJG316170

HARDWARE / SOCKET CONTACT BOM		
APCD P/N	DESCRIPTION	QTY.
200001201	FLAT WASHER, #10	1
200008201	HEX NUT, #10-32	1
200008301	LOCK WASHER, #10	1
CNS072900	M39029/22-193, CONTACT SZ 16/16	7
CNA032402	SEALING PLUG, SZ 16, MS27488-16-1	2

DIMENSIONS ANSI Y14.5M UNITS: INCHES Pro/E FILE	TOLERANCES .XX ±0.01 .XXX ±0.005 ANGLES ±2.0°	PROJECTION 	Amphenol Pcd SPECIFICATION DRAWING		TITLE SJG, SIZE 16 GROUND MODULE GOLD PLATED		
			DRWN R. SWAINE 08/29/06	ENGR <i>[Signature]</i> 10/3/06	SIZE B	DWG NO. SJG016170	REV J
ORIGINAL 	THIS DOCUMENT CONTAINS PROPRIETARY INFORMATION WHICH IS THE CONFIDENTIAL PROPERTY OF AMPHENOL PCD INC., PEABODY, MA			CODE: 58982	SCALE: 2:1	SHEET 1 OF 1	