

Atmel LED Driver-MSL3082

8-string, High-power, White or RGB LED Driver for TV,
Backlighting, or Intelligent Solid-state Lighting

Datasheet Brief



Atmel LED Driver-MSL3082

8-string, High-power, White or RGB LED Driver for TV, Backlighting, or Intelligent Solid-state Lighting

General Description

The Atmel® LED Driver-MSL3082 compact, high-power LED string driver uses external MOSFETs to provide up to at least 500mA per string, with current accuracy and matching better than $\pm 1\%$. The MSL3082 drives eight parallel strings of LEDs, and offers fault detection and management of open and short circuit LEDs.

The MSL3082 features a 1MHz I²C serial interface. The interface supports video frame-by-frame LED string intensity control for up to 16 interconnected devices, allowing active area dimming when used for video displays. The advanced PWM engine synchronizes with the video signal, and offers phase shifted string drive, virtually eliminating waterfall noise and motion blur.

The MSL3082 adaptively controls the DC-DC converters that power the LED strings, using patented Atmel's Adaptive SourcePower™ technology. These efficiency optimizers minimize power use while maintaining LED current accuracy, and allow up to eight interconnected devices to automatically negotiate the optimum power supply voltage.

A unique combination of peak current control and pulse width dimming management offers simple full-screen brightness control, versatile area dimming, and a consistent white point. LED string current is set for each string using a current sense (FET source) resistor. LED current is also digitally controlled for all eight LED strings. Global string drive pulse width is adjusted with a 6-bit global intensity register, and individual string pulse width is modulated with 8-bit control. Additionally, the MSL3082 optionally throttles back the PWM on time of all strings when the temperature of the LEDs exceeds a programmable threshold.

The MSL3082 monitors for string open circuit, LED short circuit, loss-of-sync, and over-temperature faults, and provides a hardware fault output to notify the MCU. Detailed fault status and control are available through the serial interface. Additionally, the MSL3082 includes an on-chip EEPROM that allows the power-up default register settings to be customized via the serial interface.

The MSL3082 is offered in a 7 x 7 x 0.85mm, 44-pin QFN package, and operates over a -40°C to +105°C temperature range.

Applications

- Edge-lit LED Backlit TVs
- High-contrast Monitors
- Medical and Industrial Displays
- High-power LED Arrays
- Multi-string LED Lighting
- Intelligent Solid-state Lighting (SSL)

Ordering Information

PART	INTERFACE	PACKAGE
MSL3082CS	8-channel LED driver	44-pin, 7x7x0.85mm QFN

Atmel LED Driver-MSL3082

8-string, High-power, White or RGB LED Driver for TV, Backlighting, or Intelligent Solid-state Lighting

Key Features

- 8-bit PWM String Dimming
- Fast, 1MHz I²C/Smbus Interface Supports up to 16 Devices per Bus
- 4-bit Adaptive Power Correction Maximizes Efficiency
- External Mosfets Allow >0.5a LED String Current
- Drives up to Eight Parallel, High-power Led Strings
- Multiple MSL3082s Share String Supply and Automatically Negotiate Optimum Voltage
- Supports Adaptive, Real-time 2-D Area Dimming for Highest Dynamic Range LCD TVs and Monitors
- Programmable String Phase Virtually Eliminates Motion Blur and Improves Efficiency
- Global LED Intensity Control via Serial Interface
- Supports Direct Pwm Control of all Led Strings with a Single Pwm Input Signal
- ±1% Current Accuracy and Current Balance
- Video Frame (Vsync) and Line (Hsync) Sync Inputs
- Sync Loss Detectors Optionally Disable Led Strings
- Internal Eeprom Allows Custom Power-up Default Settings
- String Open Circuit and Led Short Circuit Fault Detection
- <1μA LED String Off-leakage Current
- External Resistors Set Individual String Peak Current
- Programmable LED Over-temperature Compensation
- Automatic Die Over-temperature Protection
- I²C/SMBus Broadcast Mode Simplifies Configuration
- -40°C to +105°C Operating Temperature Range
- Lead-free, Halogen-free, RoHS-compliant Package

Application Circuit

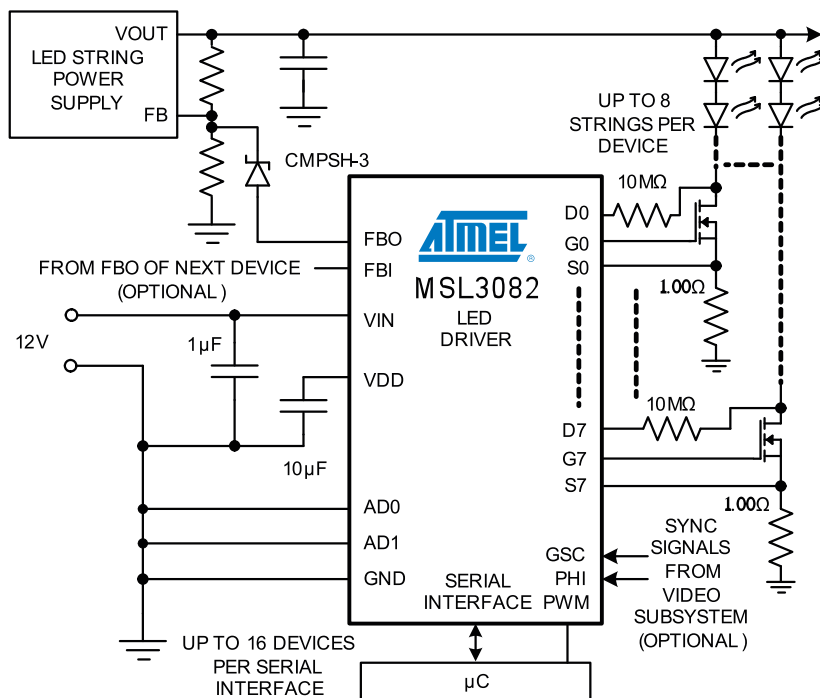



Quick Start Guide

The MSL3082 controls eight strings of series-connected LEDs at up to at least 500mA per string, and up to sixteen devices may share the serial interface. The MSL3082 FET gate drive output is optimized for FETs requiring no more than 10nC of charge. The MSL3082 PWM engine generates the PWM signal that drives the strings, or optionally accepts an external PWM signal.

How Many LEDs and Drivers?

The MSL3082 drives eight strings of series-connected LEDs using external N-channel MOSFETs and current sense resistors. The LED drive capability (maximum number of LEDs per string) is limited only by the MOSFETs and the LED string power supply, not by the MSL3082. Up to 16 MSL3082s may share an I²C/SMBus serial interface, with both individual and broadcast (all MSL3082s on a bus) addressing. The high LED drive power of the MSL3082 makes it suitable for large LCD TV and monitor backlights, as well as for LED signage and general lighting.

LEDs, the String Power Supply, and the Efficiency Optimizer

The MSL3082 features an Efficiency Optimizer output that dynamically adjusts the LED string power supply to the minimum voltage necessary to drive the LED strings, minimizing power use while assuring accurate LED current flow. The Efficiency Optimizers features an input that allows up to eight devices to be connected in a chain configuration. When implemented, the chain automatically negotiates, controls, and optimizes the string power supply for all LED strings driven by the chain.

The power supply can use any topology that employs external feedback resistors with a maximum feedback voltage of 1.5V, and are typically DC-DC boost converters. The efficiency optimizers rely on close matching of the LEDs connected to a string supply; the better the matching, the better the overall efficiency.

Differences between Atmel LED Drivers-MSL3082 and MSL2100

The MSL3082 includes a single Efficiency Optimizer, is more suited for single-color LEDs, and is ideal for driving white backlight LEDs in an LCD monitor or TV application. The MSL2100 includes three independent Efficiency Optimizer circuits to control three separate string supplies (for RGB LEDs, for example).

Timing, PWM, Intensity Controls, and Synchronization

The PWM LED drive signals synchronize to video frame timing via the PHI input, and to pixel timing via the GSC input. Suitability for LED backlight architectures is shown in Table 1 and Table 2. Area LED dimming for direct backlighting is supported for contrast and color gamut improvement. With area dimming, motion blur is reduced by setting each LED string's PWM phasing to synchronize string off times with the LCD update timing. Also, the individual PWM intensity registers for eight LED strings are updated with only 92 I²C/SMBus clocks. Sixteen drivers (128 LED strings) update in 1.47ms with a 1MHz bus speed, offering area dimming support for frame rates up to 640Hz.

Table 1. Atmel LED Driver-MSL3082 LED Common Backlight Drive Architectures

BACKLIGHT TYPE	STRING SUPPLY OPTIONS	MOTION BLUR REMOVAL	LED ZONE MANAGEMENT
White LED - bottom edge-lit	1 or more MSL3082 per efficiency optimized supply	No	No
White LED - top/bottom edge-lit		No	No
White LED - four sides edge-lit		No	No
White LED - direct back-lit		Yes - LED strip phasing	Higher contrast ratio (area dimming)
RGB LED - direct back-lit	See MSL2100 datasheet	Yes - LED strip phasing	Higher contrast ratio and color gamut

Table 2. Atmel LED Driver-MSL3082 Timing and LED Intensity Control Capability

LED INTENSITY CONTROL	RESOLUTION
LED string current	External resistors set maximum current for each LED string up to at least 500mA
Individual LED string current	6-bit ISTR registers reduce string current from maximum set by global resistor
Global LED string pulse width	6-bit GINT register or PWM input (accepts 20Hz To 50kHz, 0% to 100% duty cycle)
Individual LED string pulse width	8-bit PWM registers set individual string pulse width
Global temperature derating	6-bit temperature pulse width derating, individually applied to each string
Total LED string pulse width control	10-bit LED string pulse width, computed from global and individual pulse width settings

Package Pin-out - Atmel LED Driver-MSL3082-TB

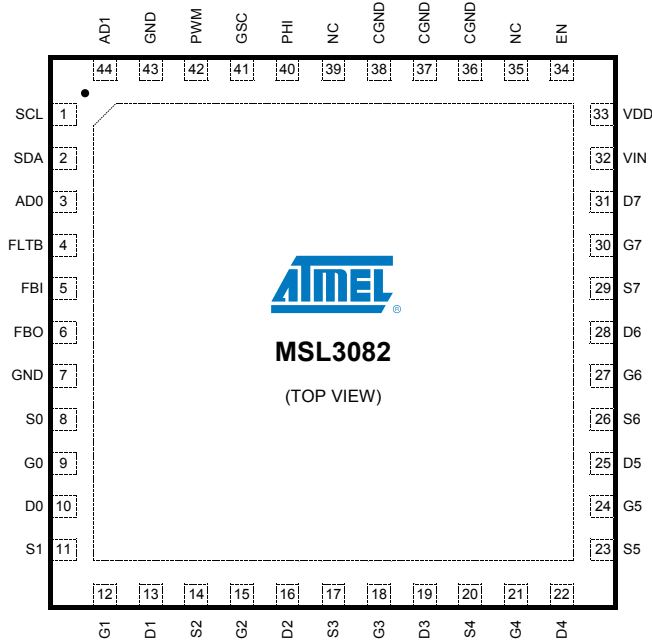

Figure 1. 44-pin, 7mm x 7mm x 0.85mm QFN (0.5mm pin pitch) with Exposed Pad

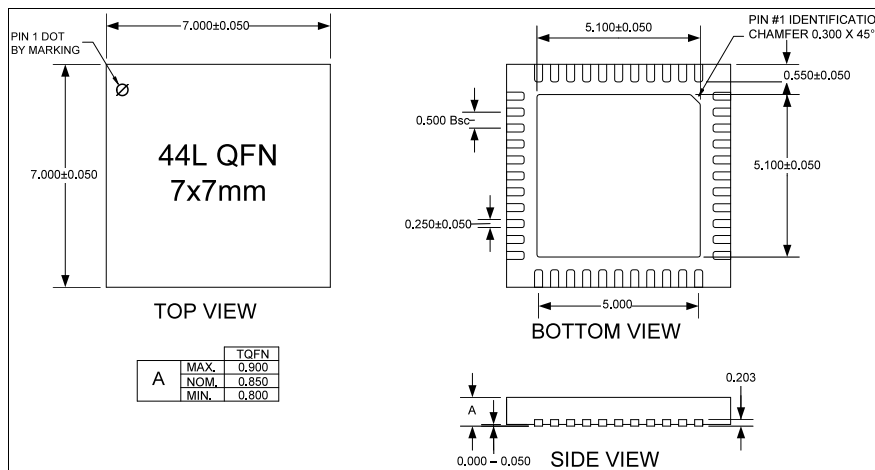

Figure 2. 44-pin QFN Package Dimensions



Pin Descriptions

PIN #	NAME	DESCRIPTION
1	SCL	I²C serial clock Input SCL is the I ² C serial interface clock input.
2	SDA	I²C serial data I/O SDA is the I ² C serial interface data I/O.
3, 44	AD1, AD0	I²C slave ID selection inputs AD0 and AD1 select the device I ² C slave address.
4	FLT B	Fault output (open drain, active low) FLT B sinks current to GND when the MSL3082 detects a fault. FLT B remains low until the fault registers have been read or EN is toggled low.
5	FBI	Efficiency Optimizer input Connect FBI to FBO of the next device when chaining the Efficiency Optimizers. If unused connect FBI to GND close to the device.
6	FBO	Efficiency Optimizer output Connect FBO through a Schottky diode to the string power supply's feedback node (Figure 4), or to FBI of the previous device (Figure 5). If unused leave FBO unconnected.
7, 43	GND	Power ground Connect GND to system ground, to CGND and to EP with short, wide traces.
8, 11, 14, 17, 20, 23, 26, 29	S ₀ - S ₇	String 0 thru 7 source sense inputs Connect S _n to the source of external MOSFET _n , and to the current sense resistor for LED string _n . The full-scale LED current is reached when 500mV is across the current sense resistor.
9, 12, 15, 18, 21, 24, 27, 30	G ₀ - G ₇	String 0 thru 7 external MOSFET gate drive outputs Connect G _n to the gate of the external MOSFET _n .
10, 13, 16, 19, 22, 25, 28, 31	D ₀ - D ₇	String 0 thru 7 external MOSFET drain sense inputs Connect D _n to the drain of external MOSFET _n through a 10MΩ resistor.
32	VIN	Supply voltage input Connect a 12V ±10% supply to VIN. Bypass VIN to GND with a 1μF ceramic capacitor placed close to VIN.
33	VDD	Internal 2.5V regulator capacitor connection Bypass VDD to GND with a 10μF ceramic capacitor placed close to the device.
34	EN	Enable input (active high) Drive EN high to turn on the MSL3082, drive EN low to turn off the MSL3082. For automatic start-up, connect EN to VIN through a 100kΩ resistor.
35, 39	NC	No connection Make no connection to NC.
36, 37, 38	CGND	Connect to ground Connect CGND to system ground, to GND and to EP using short, wide traces.
40	PHI	Phase synchronization input Drive PHI with an external signal from 40Hz to 10kHz to synchronize the PWM dimming to the signal at PHI. Connect PHI to GND if unused.
41	GSC	Gate shift clock input Drive GSC with the gate shift clock of the video signal up to 5MHz. GSC sets the resolution of PWM dimming. Connect GSC to GND if unused.
42	PWM	PWM input Drive PWM with a pulse-width-modulated signal with a duty cycle of 0% to 100% and frequency of 20Hz to 50kHz to control the brightness of all LED strings.
Exposed Pad	EP	Power ground Connect EP to system ground, GND and CGND using short, wide traces. EP offers thermal relief to the die.

Atmel LED Driver-MSL3082

8-string, High-power, White or RGB LED Driver for TV, Blacklighting, or Intelligent Solid-state Lighting

Absolute Maximum Ratings

Voltage (With Respect to GND)

VIN, EN, D0-D7, G0-G7	-0.3V to +16V
SDA, SCL, AD0, AD1, FLTB.....	-0.3V to +5.5V
PHI, GSC, PWM, S0-S7, FBI, FBO.....	-0.3V to (V _{DD} + 0.3V)
VDD	-0.3V to +2.75V

Current (Into Pin)

VIN	50mA
GND.....	-500mA
All other pins.....	20mA

Continuous Power Dissipation (See Note 8, Note 9)

44-Pin 7mm x 7mm QFN (derate 47.6mW/°C above 70°C).....	2619mW
---	--------

Ambient Operating Temperature Range T_A = T_{MIN} to T_{MAX}..... -40°C to +105°C

Junction Temperature +125°C

Storage Temperature Range..... -65°C to +125°C

Lead Soldering Temperature, 10s..... +300°C

Electrical Characteristics

(Circuit of Figure 3, VIN = 12V, T_A = T_{MIN} to T_{MAX}, unless otherwise noted. Typical values are at VIN = 12V, T_A = +25°C)

PARAMETER	CONDITIONS AND NOTES	MIN	TYP	MAX	UNIT
DC ELECTRICAL CHARACTERISTICS					
VIN operating supply voltage		10.8	12.0	13.2	V
VIN operating supply current	All drivers on at 100% duty, I ² C serial interface idle		25.0	32.5	mA
VIN shutdown supply current	EN = 0, all digital inputs tied to VDD or GND		10	20	μA
VDD regulation voltage		2.3	2.5	2.6	V
Input high voltage SDA, SCL, AD0, AD1		2.31			V
Input low voltage SDA, SCL, AD0, AD1				0.9	V
Input high voltage PHI, GSC, PWM		1.8			V
Input low voltage PHI, GSC, PWM				0.7	V
Input high voltage EN		0.9	1.36		V
Input low voltage EN				0.7	V
Input hysteresis EN			50		mV

Continued to Next Page



PARAMETER	CONDITIONS AND NOTES	MIN	TYP	MAX	UNIT
Input quiescent current EN			1	20	μA
SDA, FLTB output low voltage	Sinking 6mA			0.4	V
S0 thru S7 regulation resolution			1		% of Full Scale
Open circuit detect voltage		7.3	8.3	9.0	V
Short circuit detect voltage		6.5	7.8	9.0	V
D0 thru D7 leakage current	Voltage under 9V		0.1		μA
	Voltage between 9V to 16V			15	
G0 thru G7 maximum gate drive voltage			10		V
G0 thru G7 gate drive current		-20		20	mA
Current sense regulation voltage	ISTRx = 0x3F	488	500	508	mV
	ISTRx = 0x1F	235	250	255	mV
G0 thru G7 output current slew rate	Current rising (Note 7, Note 8)		10		mA/μs
	Current falling (Note 7, Note 8)		10		
Thermal cutoff temperature			135		°C
FBI to FBO current transfer error	Up to FBO maximum output current		±2		%
FBO current step size			3		μA
FBO feedback output current maximum	$V_{FBO-} = 0$ to 1.8V	35	45	55	μA

PARAMETER	CONDITIONS AND NOTES	MIN	TYP	MAX	UNIT
AC ELECTRICAL CHARACTERISTICS					
OSC initial accuracy	f_{OSC} OSCCTRL = 0x04 ($f_{OSC}=20$ MHz); $T_A=25^{\circ}C$	18	20	22	MHz
PHI frequency	f_{PHI} (Note 7)	40		10000	Hz
GSC frequency	f_{GSC} (Note 7)			5	MHz
PWM frequency	f_{PWM} PWMDIRECT = PWMEN = 1	20		50000	Hz
PWM duty cycle	PWMDIRECT = PWMEN = 1	0		100	%
PHI DLL Lock Cycles			4		PHI Cycles

PARAMETER	CONDITIONS AND NOTES	MIN	TYP	MAX	UNIT
I²C SWITCHING CHARACTERISTICS					
SCL clock frequency	$1/t_{SCL}$ Bus timeout disabled (Note 1)	0		1000	kHz
Bus timeout period	$t_{TIMEOUT}$ OSCCTRL = 0x04 ($f_{OSC}=20$ MHz); $T_A=25^{\circ}C$	27	30	33	ms
STOP to START condition bus free time	t_{BUF}	0.5			μs
Repeated START condition hold time	$t_{HD:STA}$	0.26			μs
Repeated START condition set-up time	$t_{SU:STA}$	0.26			μs
STOP condition set-up time	$t_{SU:STOP}$	0.26			μs
SDA data hold time	$t_{HD:DAT}$	15			ns

Atmel LED Driver-MSL3082

8-string, High-power, White or RGB LED Driver for TV, Blacklighting, or Intelligent Solid-state Lighting

PARAMETER	CONDITIONS AND NOTES		MIN	TYP	MAX	UNIT
SDA data valid acknowledge time	$t_{VD:ACK}$	(Note 2)	0.05		0.55	μs
SDA data valid time	$t_{VD:DAT}$	(Note 3)	0.05		0.55	μs
SDA data set-up time	$t_{SU:DAT}$		100			ns
SCL clock low period	t_{LOW}		0.5			μs
SCL clock high period	t_{HIGH}		0.26			μs
SDA, SCL fall time	t_F	(Note 4, Note 5)			120	ns
SDA, SCL rise time	t_R				120	ns
SDA, SCL input suppression filter period	t_{SP}	(Note 6)		50		ns

- Note 1. Minimum SCL clock frequency is limited by the bus timeout feature, which resets the serial bus interface if either SDA or SCL is held low for $t_{TIMEOUT}$. Disable bus timeout feature for DC operation
- Note 2. $t_{VD:ACK}$ = SCL low to SDA (out) low acknowledge time
- Note 3. $t_{VD:DAT}$ = minimum SDA output data-valid time following SCL low transition
- Note 4. A master device must internally provide an SDA hold time of at least 300ns to ensure an SCL low state
- Note 5. The maximum SDA and SCL rise times are 300ns. The maximum SDA fall time is 250ns. This allows series protection resistors to be connected between SDA and SCL inputs and the SDA/SCL bus lines without exceeding the maximum allowable rise time
- Note 6. The MSL3082 includes input filters on SDA, SCL, AD0, and AD1 inputs that suppress noise less than 50ns
- Note 7. Parameter is guaranteed by design, and is not production tested
- Note 8. Subject to thermal dissipation characteristics of the device
- Note 9. When mounted according to JEDEC JEP149 and JESD51-12 for a one-layer PCB, $\theta_{JA} = 21^\circ C/W$ and $\theta_{JC} = 1.3^\circ C/W$

Block Diagram

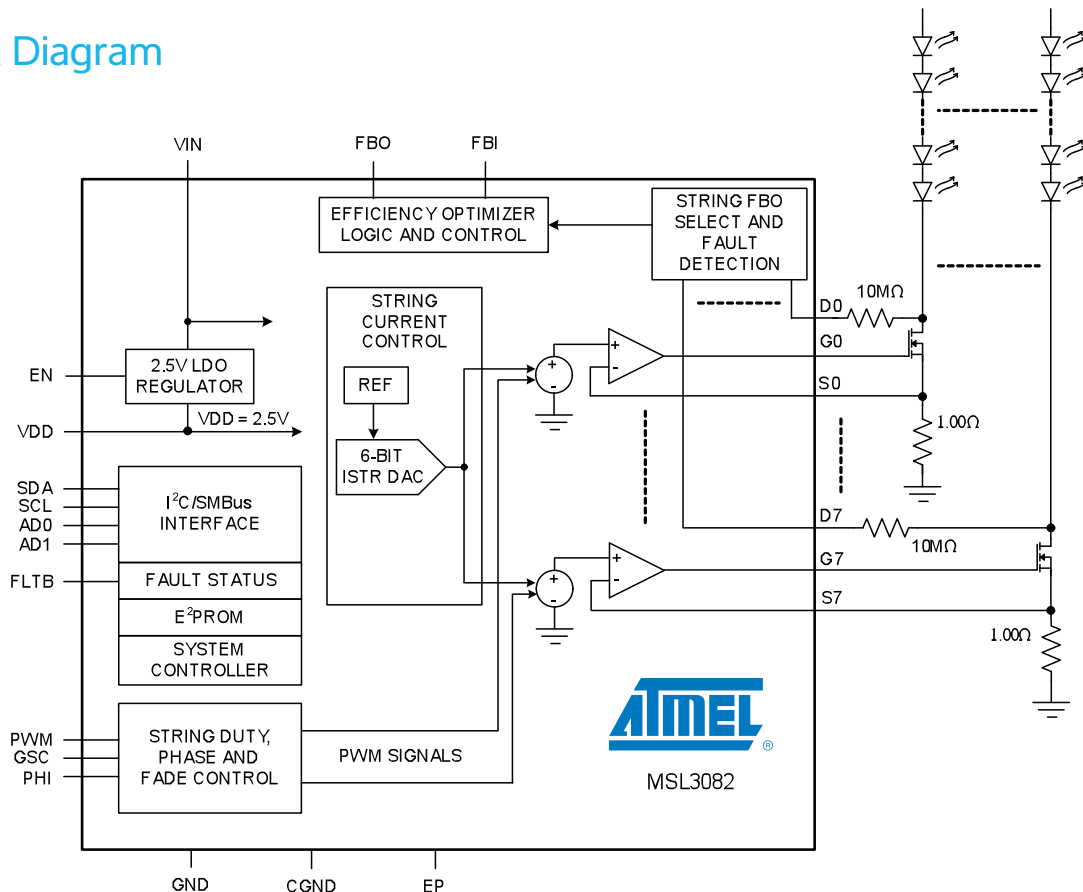

Atmel LED Driver-MSL3082 Typical Application Circuit

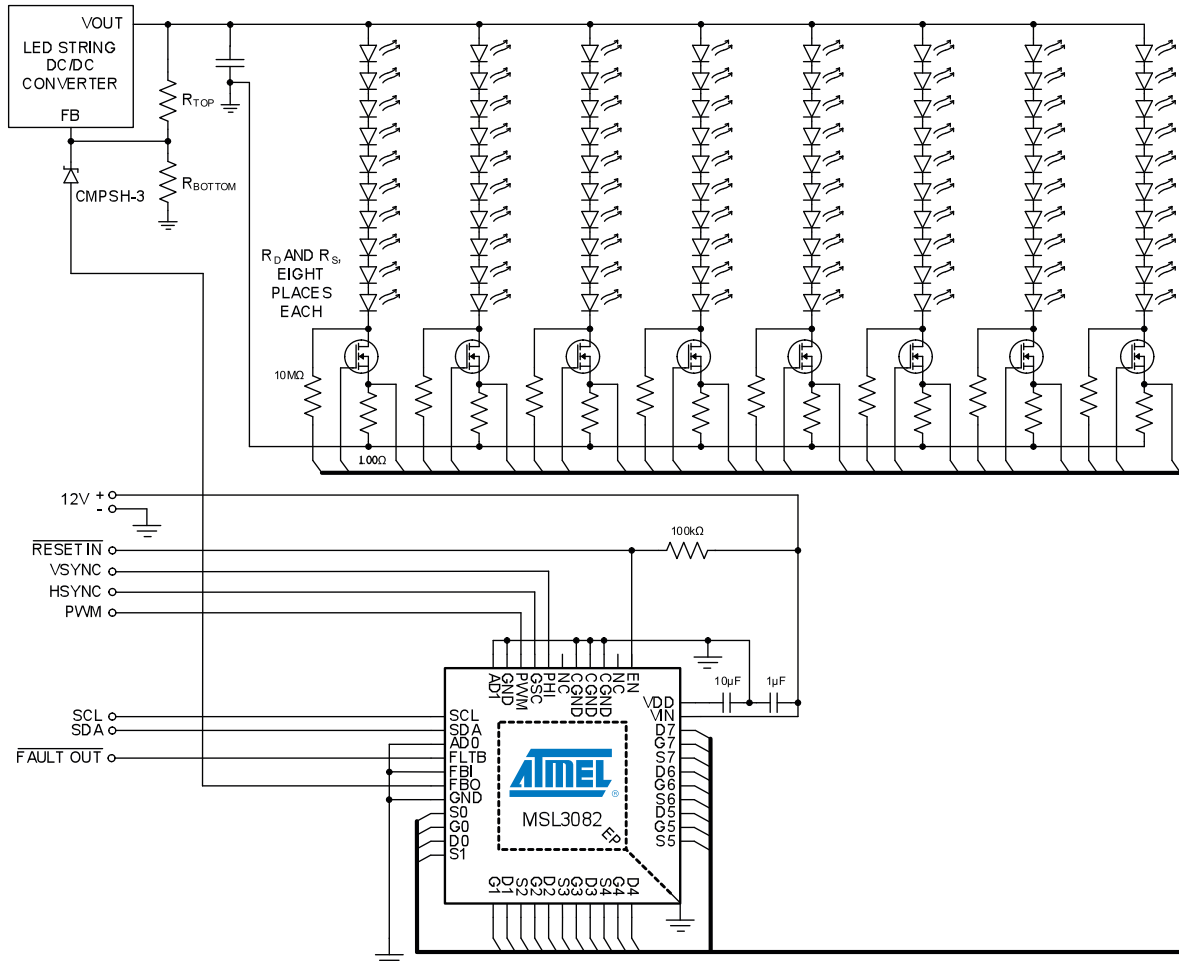

Figure 3. Typical Application Circuit

Detailed Description

The MSL3082 is a highly integrated, flexible, multi-string LED driver that uses external MOSFETs to allow high LED string currents, and includes power supply control to maximize efficiency. The driver optionally connects to a video subsystem to offer easy synchronization for use in LCD TV backlight applications. Up to sixteen devices may be connected together to drive a large number of LED strings in a system. The drivers provide multiple methods of controlling LED brightness, through both peak current control and pulse width control of the string drive signals. Peak current control offers excellent color consistency, while pulse width control allows brightness management. An on-chip EEPROM holds all the default control register values. At power-up the data in the EEPROM are automatically copied directly to the control registers, setting up the device for operation. The factory programmed EEPROM values are changeable through the serial interface if a different power-up condition is desired.

Atmel LED Driver-MSL3082

8-string, High-power, White or RGB LED Driver for TV, Blacklighting, or Intelligent Solid-state Lighting

The device interfaces to an MCU via the I²C/SMBus interface. The robust 1MHz I²C/SMBus interface supports up to sixteen devices on the bus, and is fast enough to support area dimming for 16 interconnected devices. While typically the LED drive PWM signal is internally generated by the PWM engine, the device also accepts an external direct PWM drive signal applied to the PWM input to set the frequency and duty cycle of the LED drive signals. When using the PWM engine, the MSL3082 allows phase spreading of the LED drive signals, which helps reduce the transient load on the LED power supply. Phase spreading is not supported for direct PWM drive.

The PWM frequency of the drivers is easily synchronized to an external video signal applied to PHI. Typically, the VSYNC signal from the video system is used as the PHI input. A frame-rate multiplier (1x to 16x) processes this signal for use by the PWM engine. The on-time of each string is individually programmed via the device registers, providing a peak resolution of 10 bits when using the on-chip PWM generator. The actual resolution of the PWM frequency depends on the ratio of the GSC frequency (typically provided by a systems HSYNC signal) to the PHI frequency because the on time of a string is programmed as a function (8-bit count) of the number of GSC cycles. This count can be further scaled by a 6-bit global intensity register, when enabled. The GSC clock is also used to precisely set each string's phase delay to be synchronized with its physical position relative to the video frame. Additionally, the MSL3082 features programmable temperature compensation, which throttles back the PWM on time of all strings when the temperature of the LEDs exceeds a programmable threshold.

The Efficiency Optimizers control a wide range of different external DC-DC and AC-DC converter architectures. Multiple drivers in a system communicate in real time among themselves to select an optimized operating voltage for the LEDs. This allows design of the power supply for the worst case forward voltage (V_f) of the LEDs without concern about excessive power dissipation issues. During the start-up sequence, the

MSL3082 automatically reduces the power supply voltage to the minimum voltage required to keep the LEDs in current regulation. The devices are configured to periodically perform this optimization to compensate for changes in LED forward voltage, and to assure continued optimum power savings.

Internal Regulators and Enable Input

The MSL3082 includes an internal linear regulator powered from VIN that provides 2.5V, VDD, to power the internal circuitry. Bypass VDD to GND with a 10µF or greater capacitor.

The enable input, EN, turns the VDD regulator on and off. To turn on the MSL3082 force EN high with a 5V logic level, and force EN low to turn it off. When EN is low, the MSL3082 enters low-power mode, and the serial interface is ignored. Toggling EN low also clears all fault registers and releases FLTb. Faults re-establish if the conditions that generated them persist.

Setting LED String Currents

The maximum string current, I_{LED} , for each string is set by a resistor, R_{sn} , connected to ground from the source terminal of the external string drive MOSFET. The feedback threshold is 500mV. Determine the resistor value using:

$$R_{sn} = \frac{0.5}{I_{LED}}, \text{ where } I_{LED} \text{ is in amperes and } R_{sn} \text{ is in ohms.}$$

For example, a full-scale LED current of 500mA returns $R_{sn} = 1.00\Omega$. The current for the LED strings is individually reduced from the full-scale resistor set value with 6-bit resolution using $ISTR_n$, the string current control registers 0x10 through 0x1F.



Connecting an LED String Power Supply to an Efficiency Optimizer

The MSL3082 is designed to control an external LED string power supply that uses a voltage divider (R_{TOP} and R_{BOTTOM} in Figure 4) to set the output voltage, and whose regulation feedback voltage is not more than 1.5V. The efficiency optimizer improves power efficiency by injecting a current of between 0 and 45 μ A into the voltage divider of the external power supply, dynamically adjusting the power supply's output to the minimum voltage required by the LED strings. To select the resistors first determine $V_{OUT(MIN)}$ and $V_{OUT(MAX)}$, the minimum and maximum string supply voltage limits, using:

$$V_{OUT(MIN)} = (V_{f(MIN)} * [\#ofLEDs]) + 0.5 ,$$

and

$$V_{OUT(MAX)} = (V_{f(MAX)} * [\#ofLEDs]) + 0.5 ,$$

where $V_{f(MIN)}$ and $V_{f(MAX)}$ are the LED minimum and maximum forward voltage drops at the peak current set by R_{Sn} (page 11). For example, if the LED data are $V_{f(MIN)} = 3.5V$ and $V_{f(MAX)} = 3.8V$, and ten LEDs are used in a string, then the total minimum and maximum voltage drops across a string are 35V and 38V, respectively. Adding an allowance of 0.5V for the string drive MOSFET headroom brings $V_{OUT(MIN)}$ to 35.5V and $V_{OUT(MAX)}$ to 38.5V. Then determine R_{TOP} using:

$$R_{TOP} = \frac{V_{OUT(MAX)} - V_{OUT(MIN)}}{I_{FBO(MAX)}}$$

where $I_{FBO(MAX)}$ is the 45 μ A maximum output current of the efficiency optimizer output, FBO. Finally, determine R_{BOTTOM} using:

$$R_{BOTTOM} = R_{TOP} * \frac{V_{FB}}{V_{OUT(MAX)} - V_{FB}}$$

where V_{FB} is the regulation feedback voltage of the power supply. Place a Schottky diode (CMPSH-3 or similar) between FBO and the supply's feedback node to protect the MSL3082 against current flow into FBO.

Figure 4. FBO Connection to Power Supply Voltage Divider

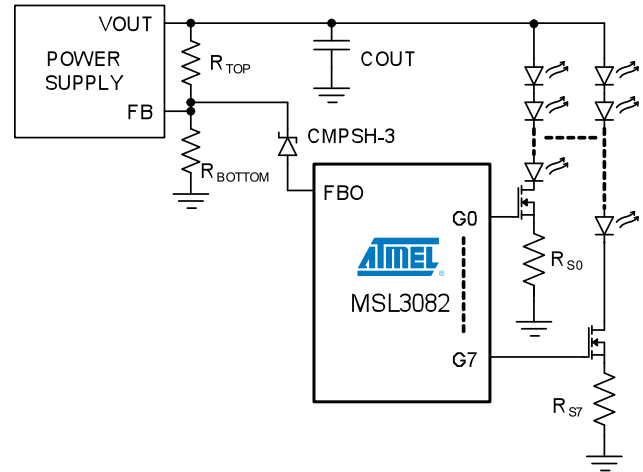

Using Multiple Atmel LED Driver-MSL3082s to Control a Single Power Supply

Cascade multiple MSL3082 devices into a chain configuration (Figure 5) with the FBI of one device connected to the FBO of the next. Connect the first FBO to the power supply feedback resistor node through a CMPSH-3 or similar Schottky diode, and the unused FBI input to ground as close to the MSL3082 as possible. The chained devices work together to ensure that the system operates at optimum efficiency. Note that the accuracy of the feedback chain has the potential to degrade through each link of the FBI/FBO chain by as much as 2%. Determine the worst case maximum FBO current, $I_{FBO(MAX/MIN)}$, using:

$$I_{FBO(MAX/MIN)} = 45\mu A * (0.98)^{N-1} ,$$

where N is the number of MSL3082s connected in series. Use this result in the above R_{TOP} resistor equation for the term $I_{FBO(MAX)}$ instead of using the 45 μ A figure shown here.

Take care in laying out the traces for the efficiency optimizer connections. Minimize the FBI/FBO trace lengths as much as possible. Do not route the signals close to traces with large variations in voltage or current because noise may couple into FBI. If these traces must be routed near noisy signals, shield them from noise by using ground planes and/or guard traces.

Atmel LED Driver-MSL3082

8-string, High-power, White or RGB LED Driver for TV, Blacklighting, or Intelligent Solid-state Lighting

Figure 5. Cascade Multiple Atmel LED Driver-MSL3082s to Control a Common Power Supply

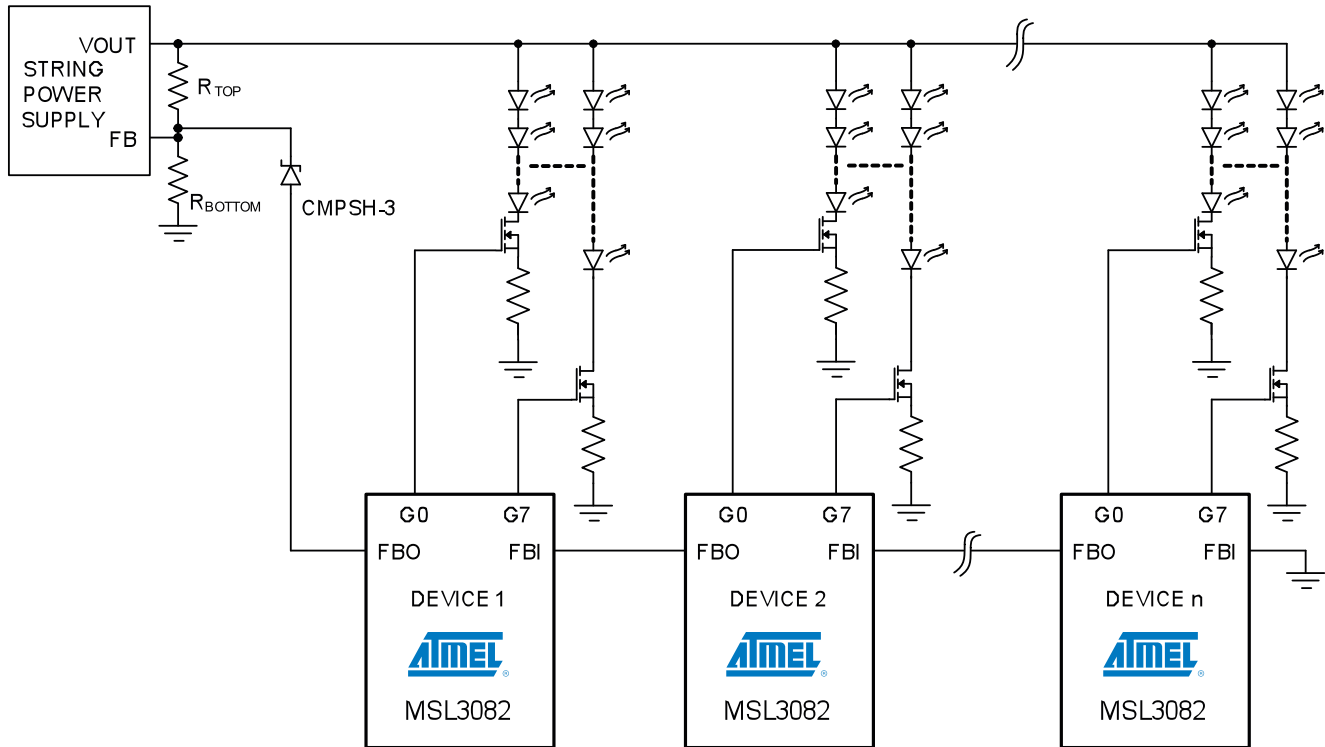

Register Map Summary

Control the MSL3082 using the registers in the range 0x00 thru 0x59 (Table 3). Two additional registers, 0x90 and 0x91, allow access to, and programming of, the EEPROM. The power-up default values for all control registers are stored within the on-chip EEPROM, and any of these EEPROM values may be changed through the serial interface.

Table 3. Atmel LED Driver-MSL3082 Register Map

REGISTER AND ADDRESS		FUNCTION	REGISTER DATA							
			D7	D6	D5	D4	D3	D2	D1	D0
CONTROL	0x00	LED string enables	STR7EN	STR6EN	STR5EN	STR4EN	STR3EN	STR2EN	STR1EN	STR0EN
0x01		UNUSED								
POWERCTRL	0x02	Power control	SLEEP	-	STRSCEN	STROCEN	PWMDIRECT	I ² CTOEN	FBOEN	PHADLYEN
OSCCTRL	0x03	Oscillator frequency	-	-	-	-	-	OSCFREQ[2:0]		
OTTEMP	0x04	Over-temp threshold	OTTEMP[7:0]							
SYSTEMP	0x05	System temperature	SYSTEMP[7:0]							



Table 3. Atmel LED Driver-MSL3082 Register Map

REGISTER AND ADDRESS		FUNCTION	REGISTER DATA							
			D7	D6	D5	D4	D3	D2	D1	D0
OTSLOPE	0x06	Over-temp derating	OTSLOPE[7:0]							
FLTSTATUS*	0x07	Fault status, global	-	STRSCDET	STROCDDET	-	-	-	FBOCAL	FLTDET
PWMCTRL	0x08	PWM and phase control, configuration	GSCDIVEN	GINTEN	PHIPOL	TDERATE	PHIMINEN	GSCMAXEN	OVRFLOEN	PWMEN
OCSTAT*	0x09	String open circuit status	OC7	OC6	OC5	OC4	OC3	OC2	OC1	OC0
SCSTAT*	0x0A	LED short circuit status	SC7	SC6	SC5	SC4	SC3	SC2	SC1	SC0
GINT	0x0B	Global intensity	-	-	GINT[6:0]					
GSCDIV	0x0C	GSC divider	-	-	-	-	GSCDIV[3:0]			
PHIMUL	0x0D	PHI multiplier	-	-	-	PHIMUL[4:0]				
STR03FBO	0x0E	String FBO enables	STR3FBO[1:0]		STR2FBO[1:0]		STR1FBO[1:0]		STR0FBO[1:0]	
STR47FBO	0x0F		STR7FBO[1:0]		STR6FBO[1:0]		STR5FBO[1:0]		STR4FBO[1:0]	
ISTR0	0x10	Individual string current throttle	-	-	ISTR0[5:0]					
to			-	-	to					
ISTR7	0x1F		-	-	ISTR7[5:0]					
PHDLY0	0x20	Individual string phase delay settings	PHDLY0[7:0]							
to			to							
PHDLY7	0x2F		PHDLY7[7:0]							
PWM0	0x30	Individual string pulse width settings	PWM0[7:0]							
to			to							
PWM7	0x3F		PWM7[7:0]							
GSCMAX	0x40	Max oscillator cycles between GSC pulses	GSCMAX[7:0]							
	0x41		GSCMAX[15:8]							
PHIMIN	0x42	Min GSC pulses over PHI period	PHIMIN[7:0]							
	0x43		-	-	-	-	PHIMIN[15:8]			
0X44 THRU 0X46			UNUSED							
FAULTEN	0x47	Individual string fault monitoring enables	FLTEN7	FLTEN6	FLTEN5	FLTEN4	FLTEN3	FLTEN2	FLTEN1	FLTEN0
0X48 THRU 0X4F			UNUSED							
FBOCTRL0	0x50	Efficiency Optimizer configuration	HDRMSTEP[1:0]		FBCLDLY[1:0]		FBSDLY[1:0]		FBCFDLY[1:0]	
FBOCTRL1	0x51		STRSCCDLY[1:0]		-	-	-	-	ACALEN	ICHKDIS
0X52 THRU 0X58			UNUSED							

Atmel LED Driver-MSL3082

8-string, High-power, White or RGB LED Driver for TV, Blacklighting, or Intelligent Solid-state Lighting

REGISTER AND ADDRESS		FUNCTION	REGISTER DATA							
			D7	D6	D5	D4	D3	D2	D1	D0
FBODAC*	0x59	Efficiency Optimizer DAC readback	FBOACT	-	-	-	FBODAC[3:0]			
DO NOT ACCESS ADDRESS RANGE 0X58 TO 0X8F										
E2ADDR	0x90	User EEPROM read/write access	-	E2ADDR[6:0]						
E2CTRLSTA	0x91		E2BUSY	BLDACT	E2ERR	-	-	RWCTRL[1:0]		

* Read-only registers

Register Power-up Defaults

Register power-up default values are shown in Table 4.

Table 4. Atmel LED Driver-MSL3082 Register Power-up Defaults

REGISTER NAME AND ADDRESS		POWER-UP CONDITION REGISTERS INITIALIZED FROM EEPROM	REGISTER DATA								HEX	
			D7	D6	D5	D4	D3	D2	D1	D0		
0x00	CONTROL	All LED strings drive outputs are enabled	1	1	1	1	1	1	1	1	1	FF
0x02	POWERCTRL	String phase delay enabled Efficiency Optimizer feedback output enabled I ² C bus timeout enabled Direct PWM disabled String open circuit detection enabled String short circuit detection enabled Device awake	0	1	1	1	0	1	1	1	1	77
0x03	OSCCTRL	Internal oscillator f _{osc} set to 20MHz	0	0	0	0	0	1	0	0	0	04
0x04	OTTEMP	Over-temperature threshold is 90°C	0	1	0	1	1	0	1	0	0	5A
0x05	SYSTEMP	System temperature set to 30°C	0	0	0	1	1	1	1	0	0	1E
0x06	OTSLOPE	Over-temperature slope set to 50°C	0	0	1	1	0	0	1	0	0	32
0x08	PWMCTRL	PWM operation enabled String on-times truncated at end of frame GSC low frequency fault detection disabled PHI high frequency fault detection disabled Over-temperature derating of string on times enabled PWM frame synchronized to rising edge at PHI input GINT global intensity control enabled GSC input frequency division disabled	0	1	1	1	0	0	0	0	1	71
0x0B	GINT	Global intensity PWM duty cycle GINT = 15/64 = 23.4%	0	0	0	0	1	1	1	1	1	0F
0x0C	GSCDIV	GSC input frequency is divided by 2 ⁰	0	0	0	0	0	0	0	0	0	00
0x0D	PHIMUL	PHI input frequency is multiplied by 1	0	0	0	0	0	0	0	0	1	01
0x0E	STR03FBO	All strings are monitored by the Efficiency Optimizer	1	1	1	1	1	1	1	1	1	FF
0x0F	STR47FBO		1	1	1	1	1	1	1	1	1	FF



REGISTER NAME AND ADDRESS		POWER-UP CONDITION REGISTERS INITIALIZED FROM EEPROM	REGISTER DATA								
			D7	D6	D5	D4	D3	D2	D1	D0	HEX
0x10 0x17	ISTR0 thru ISTR7	Individual peak string current = $\frac{0.5}{R_{Sn}} * \frac{32}{63}$	0	0	1	0	0	0	0	0	20
0x20 0x27	PHDLY0 thru PHDLY7	All string phase delays set to zero processed GSC cycles	0	0	0	0	0	0	0	0	00
0x30 0x37	PWM0 thru PWM7	All strings PWM settings equal 48 processed GSC cycles	0	0	1	1	0	0	0	0	30
0x40	GSCMAX	Maximum GSC pulse count is 0	0	0	0	0	0	0	0	0	00
0x41			0	0	0	0	0	0	0	0	00
0x42	PHIMIN	Minimum PHI pulse count is 0	0	0	0	0	0	0	0	0	00
0x43			0	0	0	0	0	0	0	0	00
0x47	FAULTEN	Fault detection is enabled for all strings	1	1	1	1	1	1	1	1	FF
0x50	FBOCTRL0	Current source error confirmation delay is 4µs FBO power supply settling time allowance is 8ms Efficiency Optimizer auto recalibration delay is 1s Efficiency Optimizer gives three steps for headroom	0	0	0	0	1	1	0	0	0C
0x51	FBOCTRL1	Current source error detection enabled Auto recalibration disabled String short circuit confirmation delay is 4µs	0	0	0	0	0	0	0	0	00
0x90	E2ADDR	User EEPROM 7-bit address = 0x00	0	0	0	0	0	0	0	0	00
0x91	E2CTRLSTA	User EEPROM read/write disabled	0	0	0	0	0	0	0	0	00

Atmel Corporation

2325 Orchard Parkway
San Jose, CA 95131
USA
Tel: (+1)(408) 441-0311
Fax: (+1)(408) 487-2600
www.atmel.com

Atmel Asia Limited

Unit 01-5 & 16, 19F
BEA Tower, Millennium City 5
418 Kwun Tong Road
Kwun Tong, Kowloon
HONG KONG
Tel: (+852) 2245-6100
Fax: (+852) 2722-1369

Atmel Munich GmbH

Business Campus
Parkring 4
D-85748 Garching b. Munich
GERMANY
Tel: (+49) 89-31970-0
Fax: (+49) 89-3194621

Atmel Japan

9F, Tonetsu Shinkawa Bldg.
1-24-8 Shinkawa
Chuo-ku, Tokyo 104-0033
JAPAN
Tel: (+81)(3) 3523-3551
Fax: (+81)(3) 3523-7581

© 2011 Atmel Corporation. All rights reserved. / Rev.: MEM-MSL3082DB1-E-US_06-11

Atmel®, logo and combinations thereof, and others are registered trademarks or trademarks of Atmel Corporation or its subsidiaries. Other terms and product names may be trademarks of others.

Disclaimer: The information in this document is provided in connection with Atmel products. No license, express or implied, by estoppel or otherwise, to any intellectual property right is granted by this document or in connection with the sale of Atmel products. EXCEPT AS SET FORTH IN THE ATMEL TERMS AND CONDITIONS OF SALES LOCATED ON THE ATMEL WEBSITE, ATMEL ASSUMES NO LIABILITY WHATSOEVER AND DISCLAIMS ANY EXPRESS, IMPLIED OR STATUTORY WARRANTY RELATING TO ITS PRODUCTS INCLUDING, BUT NOT LIMITED TO, THE IMPLIED WARRANTY OF MERCHANTABILITY, FITNESS FOR A PARTICULAR PURPOSE, OR NON-INFRINGEMENT. IN NO EVENT SHALL ATMEL BE LIABLE FOR ANY DIRECT, INDIRECT, CONSEQUENTIAL, PUNITIVE, SPECIAL OR INCIDENTAL DAMAGES (INCLUDING, WITHOUT LIMITATION, DAMAGES FOR LOSS AND PROFITS, BUSINESS INTERRUPTION, OR LOSS OF INFORMATION) ARISING OUT OF THE USE OR INABILITY TO USE THIS DOCUMENT, EVEN IF ATMEL HAS BEEN ADVISED OF THE POSSIBILITY OF SUCH DAMAGES. Atmel makes no representations or warranties with respect to the accuracy or completeness of the contents of this document and reserves the right to make changes to specifications and products descriptions at any time without notice. Atmel does not make any commitment to update the information contained herein. Unless specifically provided otherwise, Atmel products are not suitable for, and shall not be used in, automotive applications. Atmel products are not intended, authorized, or warranted for use as components in applications intended to support or sustain life.