

Customer Information Sheet

DRAWING No.: M80-789XXX

SHEET 2 OF 2

IF IN DOUBT - ASK

©

NOT TO SCALE

THIRD ANGLE PROJECTION

ALL DIMENSIONS IN mm

ORDER CODE:

M80-789XXX

TOTAL No. OF WAYS

04, 06, 08, 10, 12, 14,
16, 18, 20, 26, 34, 44

FINISH:

22 - GOLD ON CONTACT AREA
TIN/LEAD ON TAILS
42 - GOLD ON CONTACT AREA
100% TIN ON TAILS
45 - GOLD

SPECIFICATIONS:

MATERIAL:

MOULDING = POLYAMIDE 46 UL94V-0, BLACK
CONTACTS = PHOSPHOR BRONZE
LATCHES = BERYLLIUM COPPER

FINISH:

CONTACTS:

22 = 0.75µ GOLD ON CONTACT AREA.
3.0µ TIN/LEAD ON TAILS
42 = 0.75µ GOLD ON CONTACT AREA.
3.0µ 100% TIN ON TAILS
45 = GOLD

LATCH = 1.25µ NICKEL

ELECTRICAL:

CURRENT RATING (25°C) = 3.0A MAX.
CURRENT RATING (85°C) = 2.2A MAX.
WORKING VOLTAGE = 120V AC/DC
VOLTAGE PROOF = 360V AC/DC

CONTACT RESISTANCE:

INITIAL = 20 mΩ MAX.
AFTER CONDITIONING = 25 mΩ MAX.
INSULATION RESISTANCE:
INITIAL = 1000 MΩ MIN.
AFTER CONDITIONING = 100 MΩ MIN.

MECHANICAL:

DURABILITY = 500 OPERATIONS

ENVIRONMENTAL:

TEMPERATURE RANGE = -55°C TO +125°C

PACKING: TUBE

FOR COMPLETE SPECIFICATION, SEE COMPONENT SPECIFICATION C005XX (LATEST ISSUE)

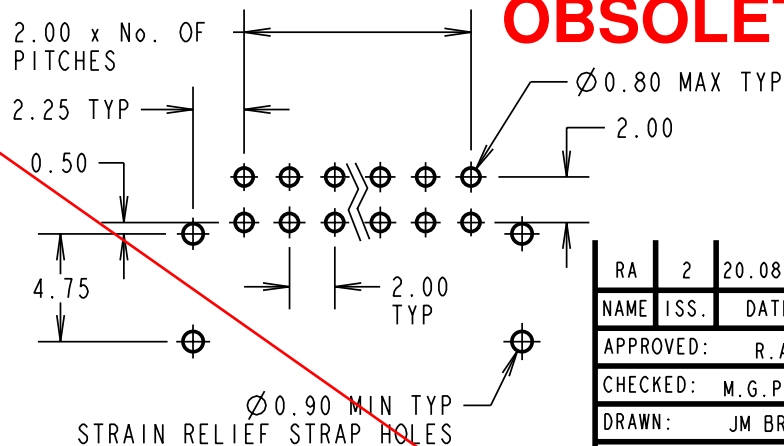
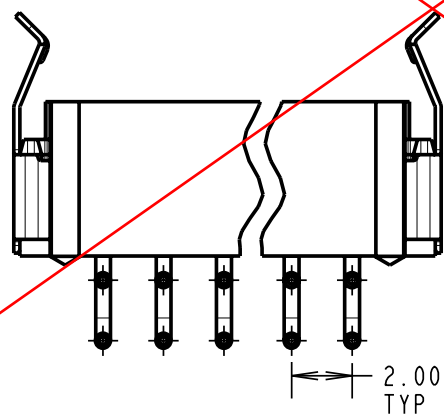
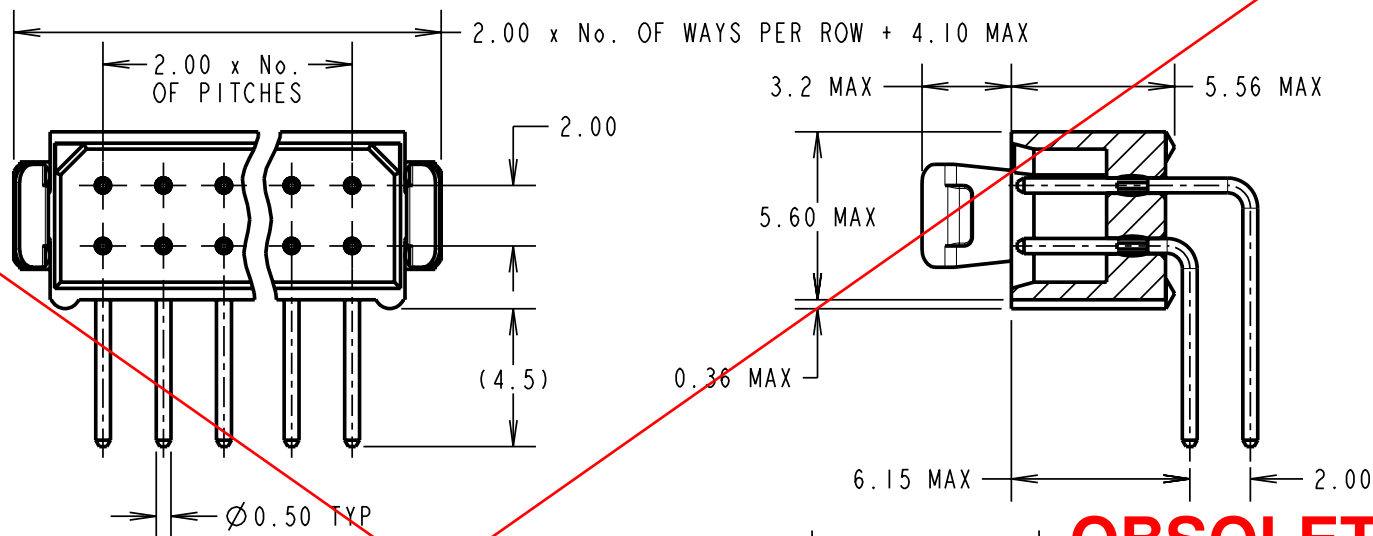

OBSOLETE

RECOMMENDED PCB LAYOUT

NOTES:

1. 2-OFF STRAIN RELIEF STRAPS
M80-0030006 ARE INCLUDED
WITH EACH CONNECTOR.

RA	2	20.08.08	----
NAME	ISS.	DATE	C/NOTE
APPROVED:		R. ADDE	
CHECKED:		M.G. PLESTED	
DRAWN:		JM BROOKES	
CUSTOMER REF.:			
ASSEMBLY DRG:			

HARWIN

HARWIN USA
TEL: 603 893 5376
FAX: 603 893 5396
mis@harwin.com

HARWIN Europe (UK)
TEL: 023 9231 4545
FAX: 023 9231 4590
mis@harwin.co.uk

HARWIN Asia
TEL: +65 6 779 4909
FAX: +65 6 779 3868
mis@harwin.com.sg

THIS DRAWING AND ANY INFORMATION OR DESCRIPTIVE MATTER SET OUT HEREON ARE CONFIDENTIAL AND COPYRIGHT PROPERTY OF THE HARWIN GROUP AND MUST NOT BE DISCLOSED, LOANED, COPIED OR USED FOR MANUFACTURING, TENDERING OR FOR ANY OTHER PURPOSE WITHOUT THEIR WRITTEN PERMISSION.

TOLERANCES
X. = ±1mm
X.X = ±0.25mm
X.XX = ±0.10mm
X.XXX = ±0.01mm
ANGLES = ±5°
UNLESS STATED

MATERIAL: SEE ABOVE
FINISH: SEE ABOVE
S/AREA: mm²

TITLE: DATAMATE DIL
HORIZONTAL MALE PC TAIL
ASSEMBLY - FRICTION LATCHED
DRAWING NUMBER: M80-789XXX

SHT 2 OF 2