

4

3

2

1

CUSTOMER DRAWING

AMPHENOL P/N
C10-729922-000

REVISION			
ZONE	REV.	DESCRIPTION	DATE
	C	UPDATE THE RECOMMEND WIRE & DIMENSION DETAIL	2017/06/19
	D	1. ADD PAGE 2 CODE NUMBER 2. REVISE SOME DIMENSIONS TO REF 3. UPDATE NOTES	2020/8/31
	E	UPDATE CODE NUMBER ON PAGE 2	2020/11/13

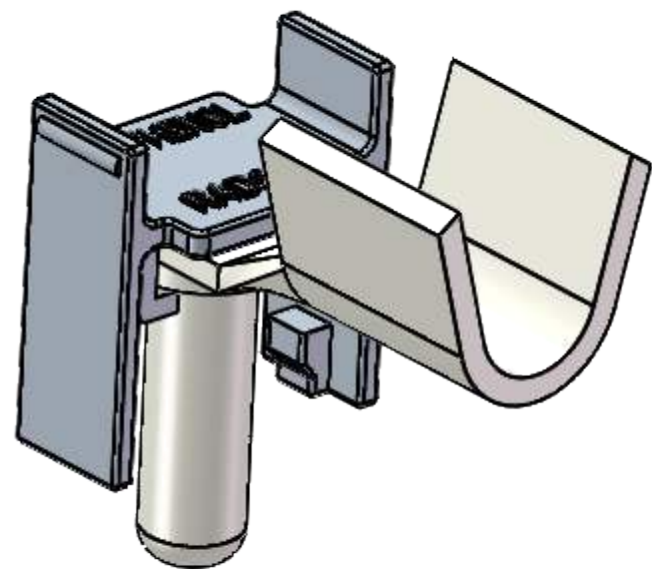

GENERAL VIEW
SCALE 4:1

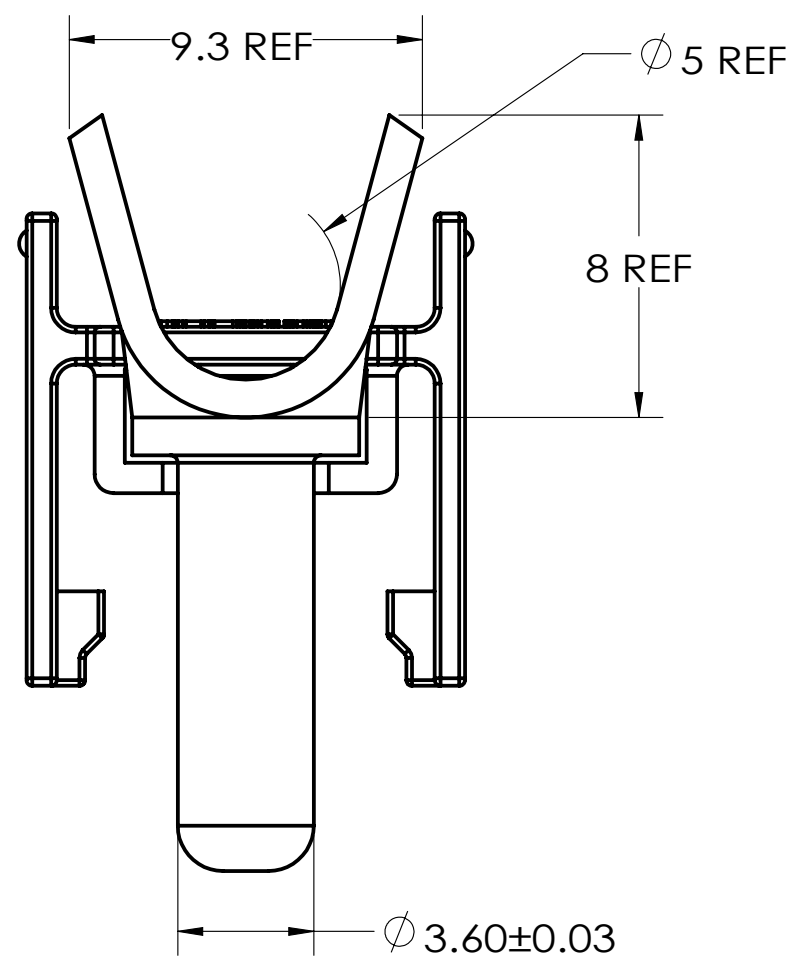
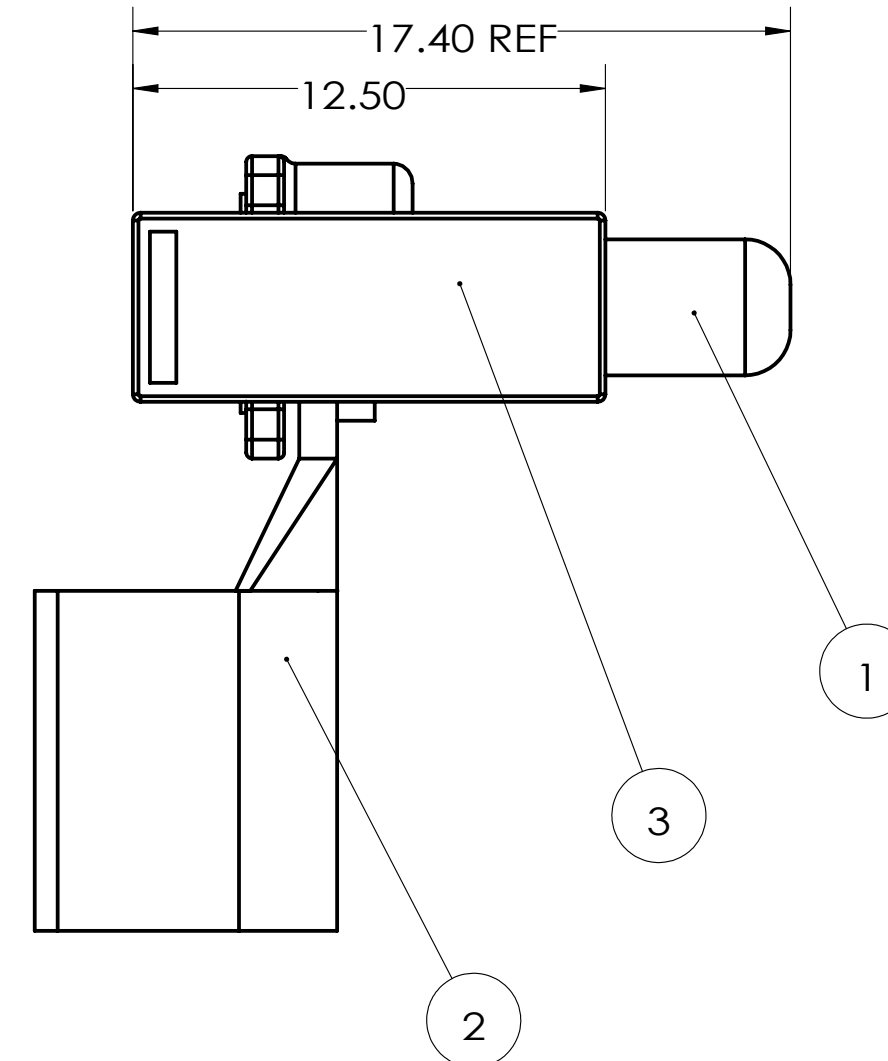
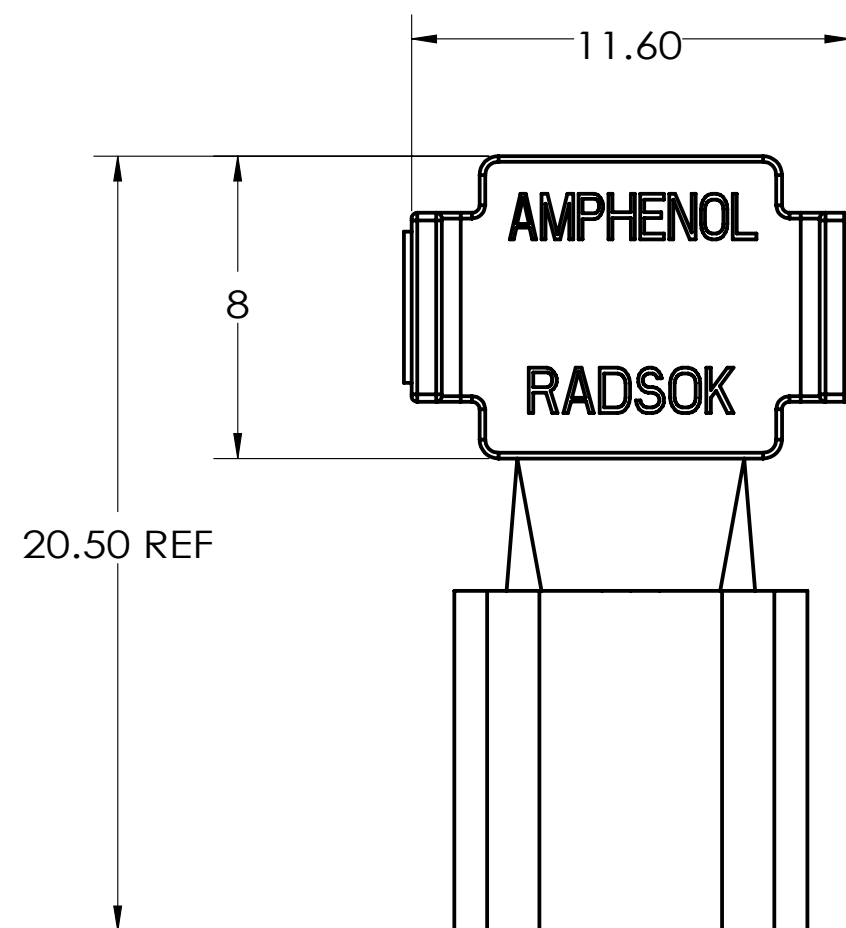

3. SPECIFICATIONS:
RATED CURRENT: 70A MAX.
RECOMMEND WIRE SIZE IS 8 AWG.

2. MATERIAL & SURFACE FINISH:
CONTACT PIN: BRASS, SILVER 3.75UM MIN OVER NICKEL 1.25UM MIN.
LUG: COPPER, TIN 2.5UM OVER NICKEL 1.25UM MIN.
LOCKING CLIP: PBT BLACK.

1. THE REFERENCED PRODUCT SHALL BE COMPLIANT TO RoHS DIRECTIVE.

NOTES

THIS DOCUMENT CONTAINS PROPRIETARY INFORMATION AND SUCH INFORMATION MAY NOT BE DISCLOSED TO OTHERS FOR ANY PURPOSE OR USED FOR MANUFACTURING PURPOSES WITHOUT WRITTEN PERMISSION FROM THE AMPHENOL CORP.

Next Assembly

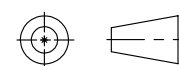

BILL OF MATERIALS				
ITEM NO.	PART NUMBER	DESCRIPTION	QTY.	UNITS
1	-	3.6 CONTACT PIN	1	PCS
2	-	LUG	1	PCS
3	-	CLIP	1	PCS

UNLESS OTHERWISE SPECIFIED		APPROVALS		DATE
LINEAR DIMENSIONS ARE IN MILLIMETERS TOLERANCES:		PREPARED BY:	ROSAN HUANG	2020/11/13
DIM. RANGE 0.5-3 >3-6 >6-30 >30-120 >120-400		LEAD/PRODUCT ENGINEER:	ROSAN HUANG	
TOLERANCE ±0.1 ±0.1±0.2 ±0.3 ±0.5		ENGINEERING MANAGER:	ROB WENG	
ANGLES = ±2°		PRODUCT GROUP:	C&I	
DIM. & TOL. PER ASME Y14.5M-1994; DRM PER MIL-DTL-31000; OTHER AMPHENOL STANDARDS: 9-9318		AIPG DIVISION:		
THIRD ANGLE PROJECTION		MATERIAL SPEC	PROCESS SPEC	
		SEE NOTE 2	N/A	

AMPHENOL CORPORATION			
Amphenol Technology (Zhuhai) Co. Ltd. No. 63 Xinghan Road, Sanzao Town, Jinwan, Zhuhai, PRC			
3.6MM WTB PIN & LOCKING CLIP ASSY, U			
8AWG			
SIZE	CAGE CODE	DOCUMENT NUMBER	REV
C	77820	10-729922	E
SCALE: 5:1		REF: -	SHEET 1 OF 2

4

3

2

1

CODE NUMBER OF WTB CONNECTORS

CODE NUMBER: WTB XXX X X XXX XXX X

CONNECTOR SERIES
WTB: WIRE TO BOARD CONNECTORS

RADSOK SIZE
XXX: RADSOK SIZE, XX.X MM
SUCH AS: "036" MEANS "3.6"MM

MATING PROPERTY
SUCH AS "X" =P, MEANS PIN SIDE
"X" =S, MEANS SOCKET SIDE

PACKAGE
"X" OMITTED MEANS STANDARD PACKAGE OF BAG

LENGTH OF SOLDER TAILS
"XXX" MEANS "X.XX"MM
SUCH AS "354" MEANS "3.54"MM
EXCEPT: "XXX"="000" MEANS PIN SIDE, NO SOLDER TAILS.

HEIGHT OVER BOARD
"XXX" MEANS "XX.X" MM
SUCH AS "174" MEANS "17.4"MM

DIRECTION OF MATING
SUCH AS "X"=R, MEANS RIGHT ANGLE
"X"=V, MEANS VERTICAL

CODE NUMBER	M P/N
WTB036PR174000	C10-729922-000

THIS DOCUMENT CONTAINS PROPRIETARY INFORMATION AND SUCH INFORMATION MAY NOT BE DISCLOSED TO OTHERS FOR ANY PURPOSE OR USED FOR MANUFACTURING PURPOSES WITHOUT WRITTEN PERMISSION FROM THE AMPHENOL CORP.

SIZE	CAGE CODE	DOCUMENT NUMBER	REV
C	77820	10-729922	E
SCALE: 8:1		REF: -	SHEET 2 OF 2

D

D

C

C

B

B

A

A