



**ANATECH ELECTRONICS INC**  
RF & Microwave Filters & Products

# 10010 MHz Cavity Bandpass Filter

**Part Number: AB10010B1138**



## Electrical specifications

**Center Frequency:** 10010 MHz  
**Bandwidth:** 320 MHz  
**Input / Output Impedance:** 50 Ohms  
**Passband:** 9850-10170 MHz  
**Passband Insertion Loss:** ≤1.0dB  
**Passband Ripple:** <0.2dB  
**Passband Return Loss:** ≥15dB  
**Rejection:** ≥70dB@9610, 10410MHz  
**Power Handling:** 2W

## Mechanical

**Connector Type:** SMA (F)  
**Dimensions:** 4.89 x 2.23 x .64 inches

## Environmental

**Operating Temperature:** -0 to +50 deg.C  
**Storage Temperature:** -55 to +95 deg.C  
**Shock:** 20 G. 11ms  
**Vibration:** 20 G. 5 to 200 Hz

## Outline Drawing:

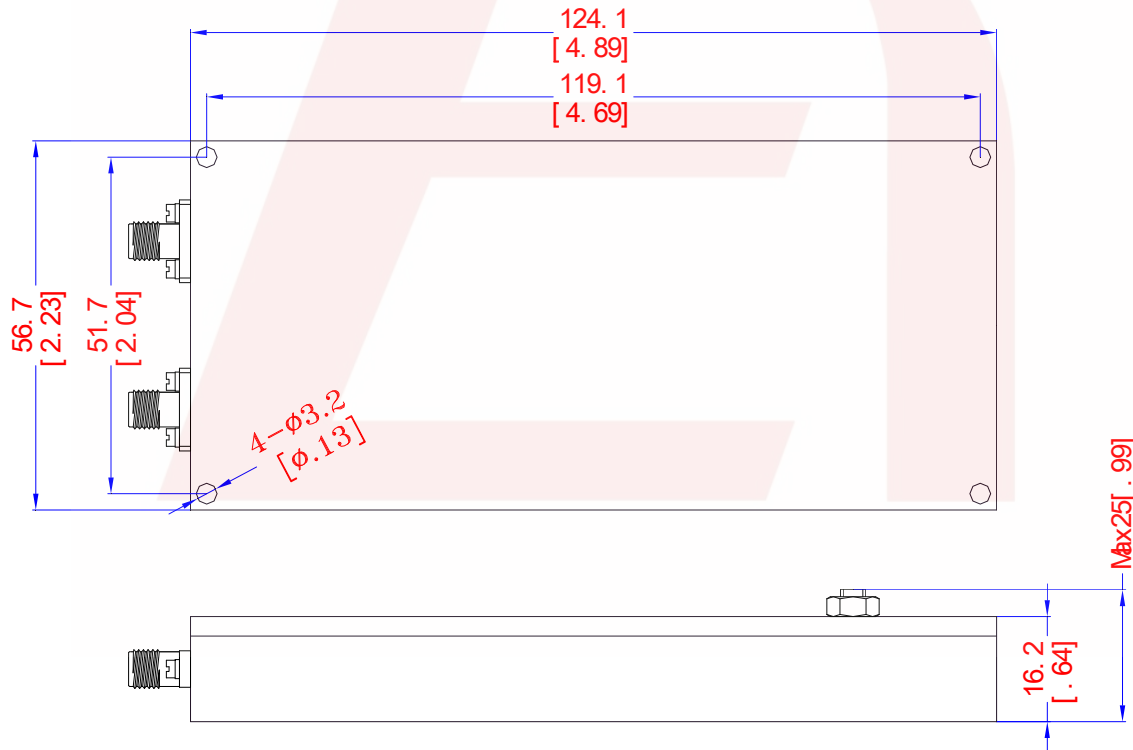

DS-B1138-03152018-Rev0



### Response Plot:

