

PAGE 1/4	ISSUE 08-04-20A	SERIES SMPM-L	PART NUMBER R201L00010
----------	-----------------	---------------	-------------------------------

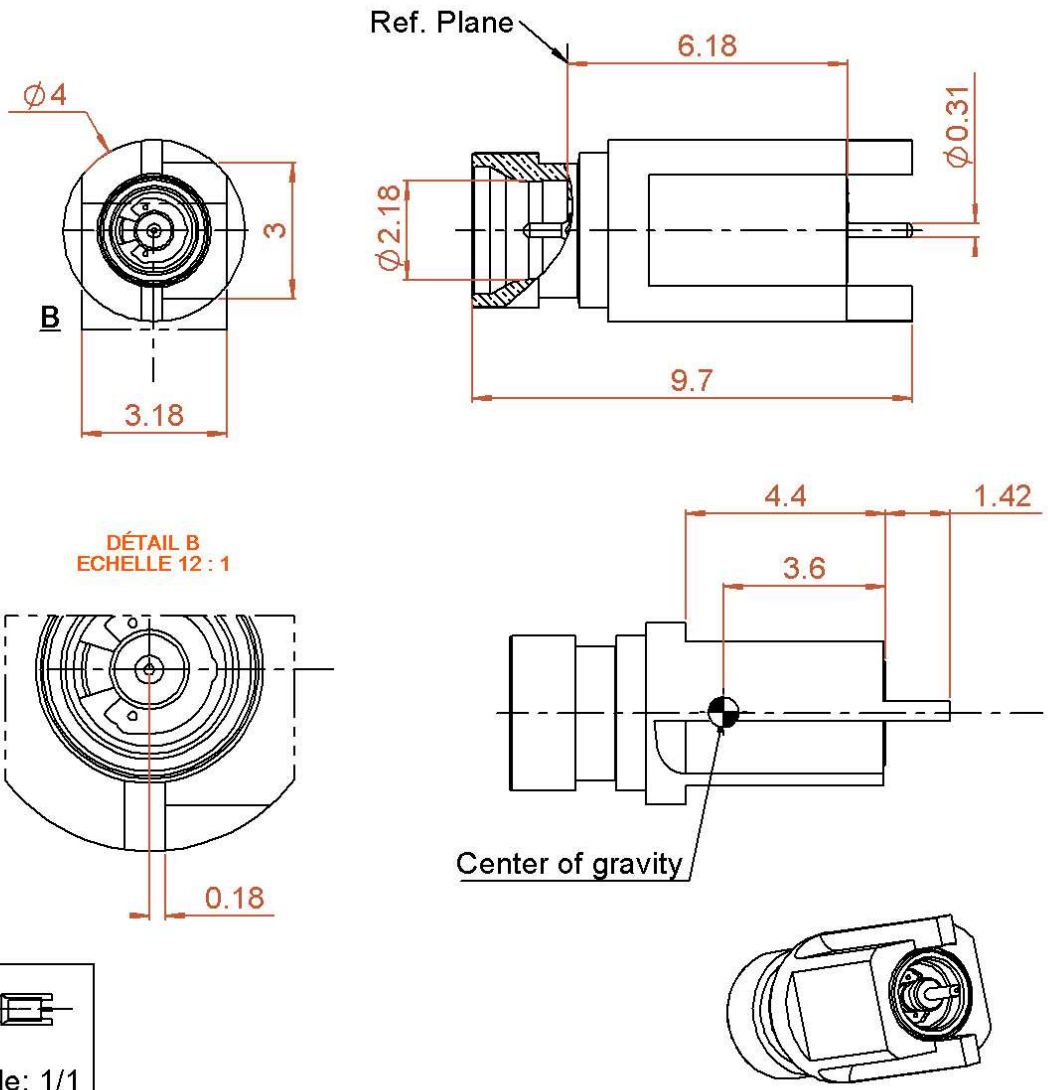

All dimensions are in mm. Tolerances according ISO 2768 m-H

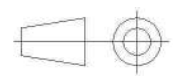

COMPONENTS	MATERIALS	PLATING (µm)
Body	BERYLLIUM COPPER	N2PGR
Center contact	BERYLLIUM COPPER	N2PGR
Outer contact		
Insulator	PEEK	
Gasket		
Others parts	BERYLLIUM COPPER	N2PGR
-	-	-
-	-	-

PAGE 3/4	ISSUE 08-04-20A	SERIES SMPM-L	PART NUMBER R201L00010
----------	-----------------	---------------	------------------------

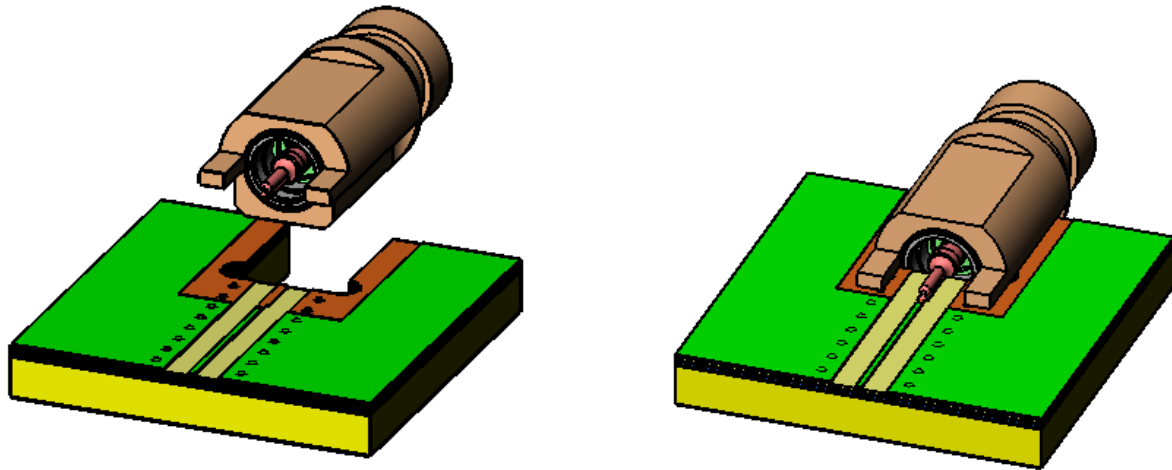

PCB Dimension

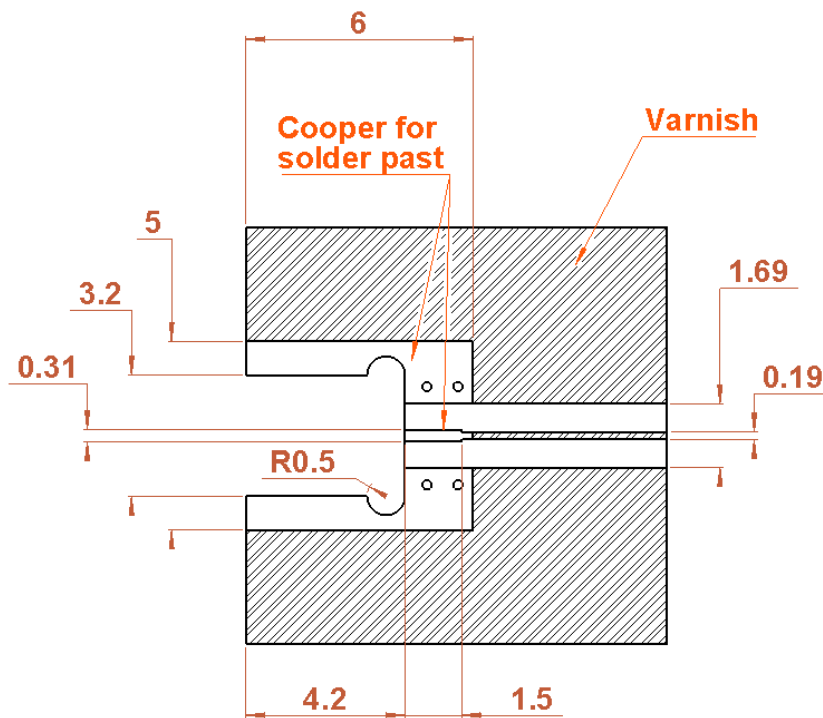

PAGE 4/4	ISSUE 08-04-20A	SERIES SMPM-L	PART NUMBER R201L00010
----------	-----------------	---------------	-------------------------------

PACKAGING

