

2-Layer EN55022 Class A Radiated Emissions Compliant Evaluation Board for the ADM2582E/ADM2587E 2.5 kV rms Signal and Power Isolated RS-485 Transceivers with ±15 kV ESD Protection

FEATURES

2.5 kV rms power and signal isolated RS-485/RS-422 transceiver
PCB layout optimized for EN55022 radiated emissions

according to the [AN-1349 Application Note](#)

[ADM2587E](#) passes EN55022 Class A (certification available)

[ADM2582E](#) passes EN55022 Class A (certification available)

2-layer printed circuit board (PCB) layout that minimizes PCB material cost

Convenient connections for power and signal through screw terminal blocks

Configurable as half-duplex or full-duplex

5 V or 3.3 V operation

Easily configurable through jumper connections

Test points for measuring all signals

EVALUATION KIT CONTENTS

[EVAL-ADM2582EEMIZ](#) or [EVAL-ADM2587EEMIZ](#)

DOCUMENTS NEEDED

[AN-1349 Application Note](#)

[ADM2582E/ADM2587E data sheet](#)

GENERAL DESCRIPTION

The [ADM2582E/ADM2587E](#) evaluation board can easily evaluate the [ADM2582E](#) and [ADM2587E](#) power and signal isolated RS-485/RS-422 transceivers. Screw terminal blocks provide convenient connections for the power and signal connections. The evaluation board is easily configured through jumper connections. The board can be used in half-duplex or full-duplex configurations and has a 120 Ω termination resistor fitted on the receiver input. The evaluation board can be used with either the [ADM2582E](#) 16 Mbps device or the [ADM2587E](#) 500 kbps device. The driver and receiver are enabled and disabled by jumper connections. Test points are included on the power and signal lines on both sides of the isolation barrier.

EN55022 RADIATED EMISSIONS

The [ADM2582E/ADM2587E](#) evaluation board is designed to reduce emissions generated by the high frequency switching elements used by the *isoPower*® technology to transfer power through the [ADM2582E/ADM2587E](#) integrated transformer. The layout of the evaluation board is generated using the guidelines provided in the [AN-1349 Application Note](#), *PCB Implementation Guidelines to Minimize Radiated Emissions on the ADM2582E/ADM2587E RS-485/RS-422 Transceivers*. The [ADM2587E](#) and [ADM2582E](#) evaluation boards are tested and certified to pass EN55022 Class A.

EVALUATION BOARD PHOTOGRAPH

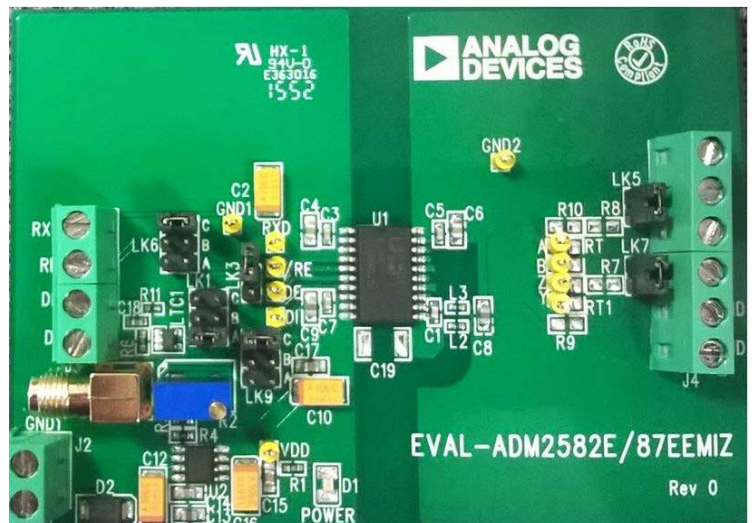

Figure 1.

TABLE OF CONTENTS

Features	1	Termination and Pull-Up/Pull-Down Resistors	4
Evaluation Kit Contents.....	1	Decoupling and Reservoir Capacitors.....	4
Documents Needed.....	1	Board Internal Layer Thickness	4
General Description	1	PCB Layout Reccomendations	4
EN55022 Radiated Emissions	1	EN55022 Radiated Emissions Test Results	5
Evaluation Board Photograph.....	1	Evaluation Board Schematics and Artwork.....	8
Revision History	2	Ordering Information.....	10
Evaluation Board Hardware.....	3	Bill of Materials.....	10
Test Setup.....	3	Related Links.....	11
Jumper Settings.....	3		

REVISION HISTORY

5/2016—Revision 0: Initial Version

EVALUATION BOARD HARDWARE

TEST SETUP

The [ADM2582E/ADM2587E](#) evaluation board is shown in Figure 2 with the default jumper settings on the LK1 through LK9 jumper blocks. In the default jumper connections, both the [ADM2582E/ADM2587E](#) driver and receiver are enabled. Figure 2 also shows the power connection on the J2 terminal block, input signal connection on the DI jack, and probes attached to the RXD, DI, Y, and Z test points for a loopback test (LK5 and LK7 are closed to connect A to Y pins and B to Z pins, respectively).

JUMPER SETTINGS

The inputs to the [ADM2582E/ADM2587E](#) can be configured using the jumpers on the evaluation board (see Table 1). Do not place multiple jumper blocks on the LK1, LK3, and LK6 jumper blocks because the input sources may be shorted together. For each link, a single jumper block can move from one position to another, as specified in Table 1.

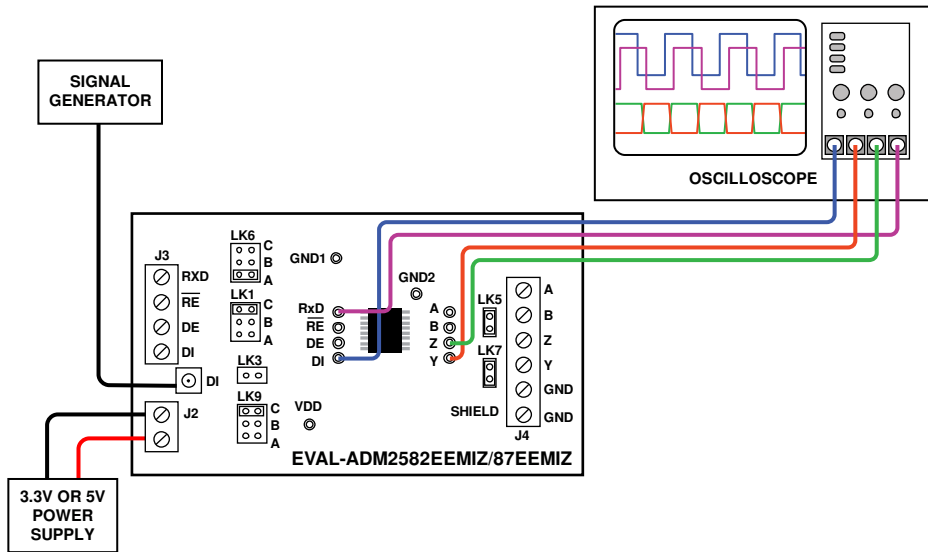

Figure 2. Basic Operation of the EN55022 Class A Compliant Evaluation Board for the [ADM2582E/ADM2587E](#) Isolated RS-485/RS-422 Transceivers

Table 1. Jumper Configuration

Link	Connection	Description
LK1	A	Connects the driver enable input (DE) of the ADM2582E/ADM2587E to V _{CC} pin. This setting enables the driver.
	B	Connects the driver enable input (DE) of the ADM2582E/ADM2587E to the DE J3 terminal block connector.
	C	Connects the driver enable input (DE) of the ADM2582E/ADM2587E to GND ₁ pin. This setting disables the driver.
LK6	A	Connects the receiver enable input ($\overline{\text{RE}}$) of the ADM2582E/ADM2587E to V _{CC} pin. This setting disables the receiver.
	B	Connects the receiver enable input ($\overline{\text{RE}}$) of the ADM2582E/ADM2587E to the $\overline{\text{RE}}$ J3 terminal block connector.
	C	Connects the receiver enable input ($\overline{\text{RE}}$) of the ADM2582E/ADM2587E to GND ₁ pin. This setting enables the receiver.
LK3	Closed	Connects the receiver enable input ($\overline{\text{RE}}$) of the ADM2582E/ADM2587E to the driver enable input (DE). This setting ensures that when the driver is enabled, the receiver is disabled, or when the driver is disabled, the receiver is enabled.
LK9	A	Connects the TxD pin of the ADM2582E/ADM2587E to the DI connector.
	B	Connects the TxD pin of the ADM2582E/ADM2587E to the DI J3 terminal block connector.
	C	Connects the TxD pin of the ADM2582E/ADM2587E to the on-board oscillator circuit.
LK5	Closed	Connects the ADM2582E/ADM2587E Receiver Input B to Driver Output Z. When LK5 and LK7 are both connected, the evaluation board is configured for half-duplex operation.
	Open	When LK5 and LK7 are both open, the evaluation board is configured for full-duplex operation.
LK7	Closed	Connects the ADM2582E/ADM2587E Receiver Input A to Driver Output Y. When LK5 and LK7 are both connected, the evaluation board is configured for half-duplex operation.
	Open	When LK5 and LK7 are both open, the evaluation board is configured for full-duplex operation.

TERMINATION AND PULL-UP/PULL-DOWN RESISTORS

The evaluation board includes the RT and RT1 footprints for fitting termination resistors between the A and B receiver inputs and the Y and Z driver outputs. By default, the board is not fitted with a 120 Ω resistor, RT, between A and B. This resistor must be removed if the board is connected to a bus that is already terminated at both ends. For more information about proper termination, see the [AN-960 Application Note](#), *RS-485/RS-422 Circuit Implementation Guide*.

Although the [ADM2582E/ADM2587E](#) have a built-in receiver fail-safe for the bus idle condition, there are footprints on the evaluation board for fitting the R9 and R10 pull-up resistors to the V_{ISOOUT} supply of the [ADM2582E/ADM2587E](#) on A and Y, as well as the R7 and R8 pull-down resistors to GND_2 on B and Z. These resistors can be fitted if the user is connecting to other devices that require external biasing resistors on the bus. The exact value required for a 200 mV minimum differential voltage in the bus idle condition depends on the supply voltage (for example, 960 Ω for 3.3 V and 1440 Ω for 5 V).

For more information about the bus idle fail-safe, see the [AN-960 Application Note](#), *RS-485/RS-422 Circuit Implementation Guide*.

DECOUPLING AND RESERVOIR CAPACITORS

The evaluation board uses the following decoupling and reservoir capacitors:

- On the logic side of the board, the C3 and C4 capacitors must be 10 nF and 100 nF ceramic capacitors, respectively, and the C2 capacitor must be a 10 μ F tantalum capacitor.
- On the logic side of the board, the C7 capacitor must be a 100 nF ceramic capacitor, and the C9 capacitor must be a 10 μ F tantalum capacitor.
- On the logic side of the board additional capacitors are added for the power regulation circuits. C12, C13, and C16 must be a 10 μ F tantalum capacitors, while C14 and C15 must be 100 nF ceramic capacitors.
- On the bus side of the board, the C5 and C6 capacitors must be 10 nF and 100 nF, respectively, and the C1 and C98 capacitors must be 100 nF and 10 μ F, respectively.

BOARD INTERNAL LAYER THICKNESS

The [ADM2582E/ADM2587E](#) evaluation board consists of two layers. The spacing between the top and bottom layer is 1.6 mm.

The [EVAL-ADM2582EEMIZ](#) and [EVAL-ADM2587EEMIZ](#) PCB has a layer spacing of 0.4 mm between Layer 1 and Layer 2, meeting requirements for isolation standards IEC 61010, third edition, and IEC 60950 in the [AN-1109 Application Note](#), *Recommendations for Control of Radiated Emissions with iCoupler Devices*.

PCB LAYOUT RECCOMENDATIONS

The [ADM2582E/ADM2587E](#) evaluation board is designed to reduce emissions generated by the high frequency switching elements used by the *isoPower* technology to transfer power through the [ADM2582E/ADM2587E](#) integrated transformer. The layout of the evaluation board is generated using the guidelines provided in the [AN-1349 Application Note](#).

The [AN-1349 Application Note](#) provides examples of 4-layer PCBs. The [EVAL-ADM2582EEMIZ](#) and [EVAL-ADM2587EEMIZ](#) PCB layout is a 2-layer PCB. To pass EN55022 Class A on a 2-layer PCB, the following layout guidelines are recommended:

- Ensure that there is good decoupling on the PCB (see the Decoupling and Reservoir Capacitors section).
- Place a ferrite bead between the PCB trace connections and the following IC pins: V_{ISOOUT} (Pin 12) and GND_2 (Pin 11 and Pin 14).
- Do not connect the V_{ISOOUT} pin to a power plane; connect between V_{ISOOUT} and V_{ISOIN} using a PCB trace. Ensure V_{ISOIN} (Pin 19) is connected through the L3 ferrite to V_{ISOOUT} (Pin 12) as shown in Figure 3.
- Place a high voltage discrete capacitor connected between GND_1 (Pin 10) and GND_2 (Pin 11). The [EVAL-ADM2582EEMIZ](#) requires a high voltage discrete capacitor in order to pass EN 55022 Class A with adequate margin to allow for test variation. However, the [EVAL-ADM2587EEMIZ](#) can pass EN 55022 Class A without a high voltage discrete capacitor. Adding a high voltage discrete capacitor to the [EVAL-ADM2587EEMIZ](#) allows a larger pass margin from the EN55022 Class A limits.

The following additional notes apply to the PCB layout; refer to the schematic and artwork in Figure 10 to Figure 13.

- Ensure GND_2 (Pin 14) is connected to GND_2 (Pin 11) on the inside (device side) of the C1 100 nF capacitor.
- Ensure the C1 capacitor is connected between V_{ISOOUT} (Pin 12) and GND_2 (Pin 11) on the device side of the L2 and L3 ferrites.
- Ensure GND_2 (Pin 16) is connected to GND_2 (Pin 11) on the outside (bus side) of the L2 ferrite as shown in Figure 3.
- Ensure that there is a keep out area for the GND_2 plane in the PCB layout around the L2 and L3 ferrites. The keep out area means there must not be a GND_2 fill on any layer below the L2 and L3 ferrites.
- Ensure there is a minimum of 4 mm separation gap between the GND_2 plane fill and the GND_2 fill for the C19 high voltage discrete capacitor pad.

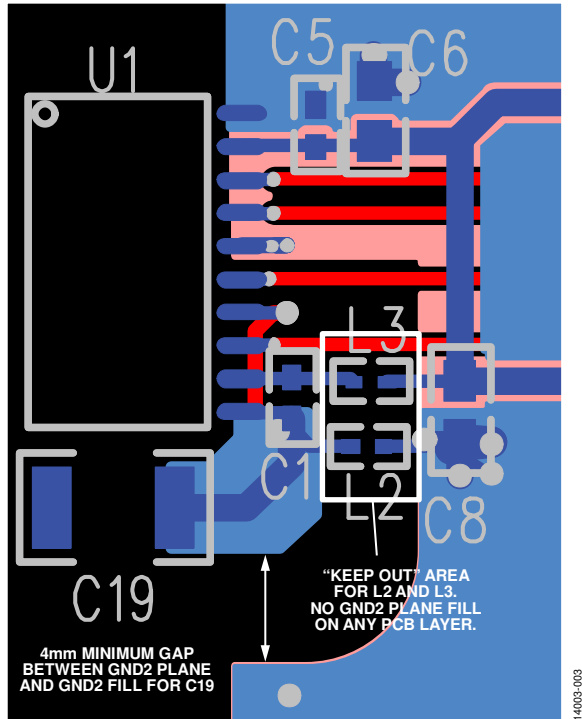

Figure 3. Layout Notes for EVAL-ADM2582EEMIZ and EVAL-ADM2587EEMIZ

- Locate the power delivery circuit in close proximity to the ADM2587E/ADM2582E device, so the V_{CC} trace is as short as possible. The EVAL-ADM2582EEMIZ and EVAL-ADM2587EEMIZ PCB has a power delivery circuit located at the bottom of the PCB with a short trace from the ADP667ARZ regulator output to V_{CC} (Pin 8). This layout example minimizes the loop area in which high frequency current can flow. An increase in the loop area results in an increase in the emissions levels.

EN55022 RADIATED EMISSIONS TEST RESULTS

The ADM2587E evaluation board is tested and certified to pass EN55022 Class A with >6 dB μ V margin. The ADM2582E evaluation board is tested and certified to pass EN55022 Class A. EN55022 Certification documents for the EVAL-ADM2582EEMIZ and EVAL-ADM2587EEMIZ evaluation boards are available to customers upon request from Analog Devices, Inc.

Table 3 provides a summary of the capability of the EVAL-ADM2582EEMIZ and EVAL-ADM2587EEMIZ evaluation boards. All EN55022 radiated emissions tests are performed with the PCB schematic and layout as described in Figure 10 to Figure 13. The C19 capacitor (See Figure 10) high voltage discrete capacitor is removed for some tests. Table 2 describes the effect of removing or adding the capacitor.

Table 2. EN55022 Test Results Summary

Device	Configuration	EN 55022 Result
ADM2587E	C19 not fitted	Pass Class A (3.9 dB μ V margin)
ADM2582E	C19 not fitted	Pass Class A (1.2 dB μ V margin)
ADM2582E	C19 fitted	Pass Class A (with a larger 7.5 dB μ V margin)

The EVAL-ADM2582EEMIZ and EVAL-ADM2587EEMIZ evaluation boards are configured and tested with 3.3 V V_{CC} or 5.0 V V_{CC} power supplied to the ADM2582E and ADM2587E devices, with the power supplied from the ADP667ARZ regulator output to V_{CC} (Pin 8). The ADP667ARZ regulator input is supplied from a standard 9 V battery. All EN55022 radiated emissions testing is performed with 9 V batteries. Testing is performed at 500 kbps clock (ADM2587E) or 16 Mbps clock (ADM2582E), with the clock supplied by the on-board oscillator. The ADM2587E/ADM2582E transceiver is connected in full-duplex mode and the bus pins are loaded with a 54 Ω termination resistor (maximum bus loading). Measurements are carried out in an anechoic chamber at 10 m from 30 MHz to 2 GHz. Figure 4 to Figure 9 show the results of the worst case horizontal scans and Table 3 to Table 8 show the tabulated quasi-peak (QP) results.

Table 3. ADM2587E 3.3V V_{CC} Test Results (Not Using a High Voltage Discrete Capacitor Between GND₁ and GND₂)

Frequency (MHz)	QP Level dB (μ V/m)	EN55022 Class A dB (μ V/m)	Antenna Position	Antenna Height (m)	Pass/Fail
180.0040	26.7	40	Horizontal	4	Pass
358.4040	34.0	47	Vertical	3.5	Pass
359.9560	43.1	47	Horizontal	2.5	Pass

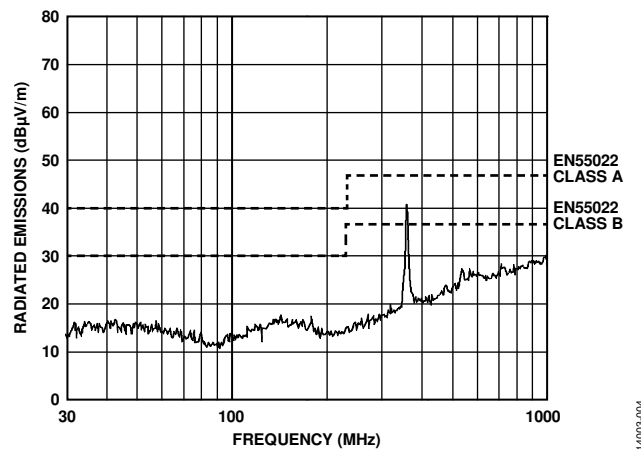

Figure 4. Horizontal Scan from 30 MHz to 1000 MHz (Corresponds to Worst Case for Table 3)

Table 4. ADM2587E 5.0 V V_{CC} Test Results (Not Using a High Voltage Discrete Capacitor Between GND₁ and GND₂)

Frequency (MHz)	QP Level dB (μV/m)	EN55022 Class A dB (μV/m)	Antenna Position	Antenna Height (m)	Pass/Fail
199.9120	24.6	40	Horizontal	4	Pass
399.1040	43	47	Horizontal	4	Pass
399.1280	32.2	47	Vertical	3.5	Pass

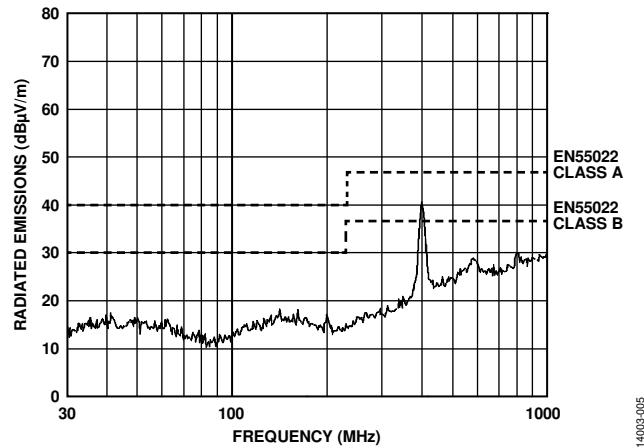

Figure 5. Horizontal Scan from 30 MHz to 1000 MHz (Corresponds to Worst Case for Table 4)

Table 5. ADM2582E 3.3V V_{CC} Test Results (Not Using a High Voltage Discrete Capacitor Between GND₁ and GND₂)

Frequency (MHz)	QP Level dB (μV/m)	EN55022 Class A dB (μV/m)	Antenna Position	Antenna Height (m)	Pass/Fail
1978.996	27.7	40	Horizontal	4	Pass
356.948	45.8	47	Horizontal	2.5	Pass
357.060	35.3	47	Vertical	3.2	Pass
500.148	27.5	47	Horizontal	2	Pass
535.000	30.5	47	Horizontal	2	Pass
591.888	30.9	47	Horizontal	1.5	Pass

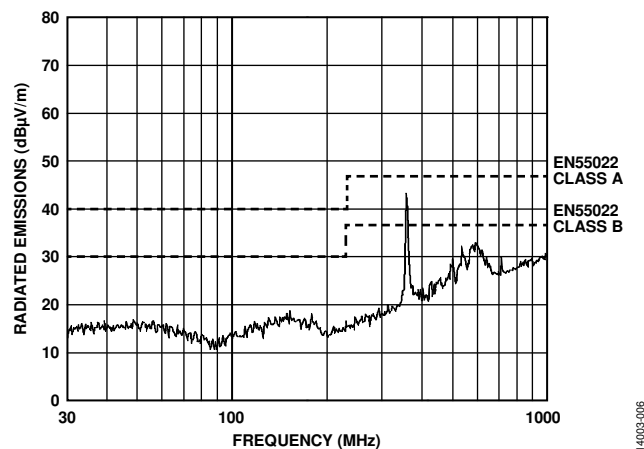

Figure 6. Horizontal Scan from 30 MHz to 1000 MHz (Corresponds to Worst Case for Table 5)

Table 6. ADM2582E 5.0 V V_{CC} Test Results (Not Using a High Voltage Discrete Capacitor Between GND₁ and GND₂)

Frequency (MHz)	QP Level dB (μV/m)	EN55022 Class A dB (μV/m)	Antenna Position	Antenna Height (m)	Pass/Fail
197.904	25.6	40	Horizontal	4	Pass
309.536	24.6	47	Horizontal	3	Pass
350.776	28.8	47	Horizontal	2.5	Pass
397.528	32.9	47	Vertical	3	Pass
397.676	42.3	47	Horizontal	2	Pass
426.356	20.5	47	Horizontal	2.5	Pass
456.100	19.3	47	Horizontal	3	Pass
462.036	36.4	47	Horizontal	1.5	Pass
497.816	20.2	47	Horizontal	2	Pass
568.904	27.5	47	Vertical	2	Pass
588.344	33.7	47	Horizontal	1.8	Pass
634.872	36.0	47	Horizontal	1.5	Pass
660.716	30.4	47	Horizontal	1.2	Pass

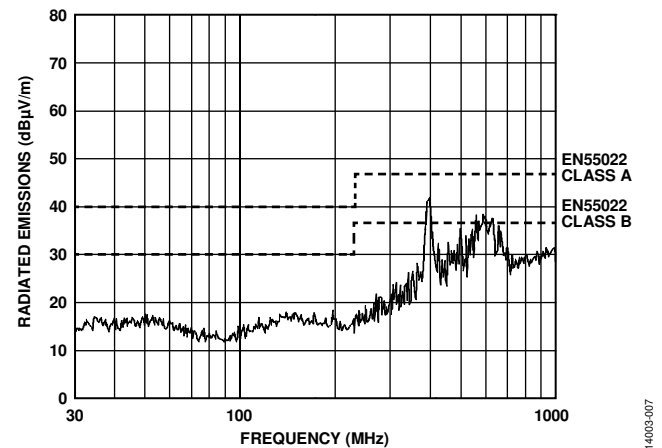

Figure 7. Horizontal Scan from 30 MHz to 1000 MHz (Corresponds to Worst Case for Table 6)

Table 7. ADM2582E 3.3 V V_{CC} Test Results (Using a High Voltage Discrete Capacitor Between GND₁ and GND₂)

Frequency (MHz)	QP Level dB (μV/m)	EN55022 Class A dB (μV/m)	Antenna Position	Antenna Height (m)	Pass/Fail
179.120	26.7	40	Horizontal	4	Pass
357.172	30.2	47	Horizontal	3	Pass
559.008	31.7	47	Horizontal	2	Pass
714.1080	27.4	47	Horizontal	1.2	Pass
892.448	33.3	47	Horizontal	1	Pass

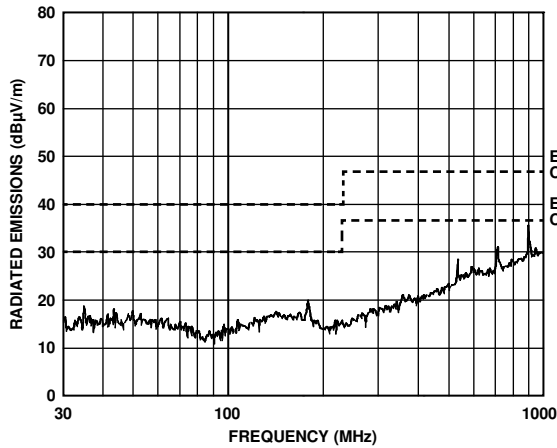

Figure 8. Horizontal Scan from 30 MHz to 1000 MHz (Corresponds to Worst Case for Table 7)

14003-008

Table 8. ADM2582E 5.0 V V_{CC} Test Results (Using a High Voltage Discrete Capacitor Between GND₁ and GND₂)

Frequency (MHz)	QP Level dB (μV/m)	EN55022 Class A dB (μV/m)	Antenna Position	Antenna Height (m)	Pass/Fail
197.740	23.6	40	Horizontal	4	Pass
344.228	28	47	Horizontal	3	Pass
394.000	30.1	47	Horizontal	2.5	Pass
425.216	31.6	47	Horizontal	2.2	Pass
465.760	32.8	47	Horizontal	2	Pass
492.064	32.2	47	Horizontal	2.5	Pass
496.700	32.8	47	Horizontal	1.8	Pass
532.980	25.3	47	Horizontal	2	Pass
537.196	28.5	47	Vertical	3	Pass
537.308	38.8	47	Horizontal	1.5	Pass
562.532	38.6	47	Horizontal	1.8	Pass
577.768	39.1	47	Horizontal	2	Pass
583.396	33.9	47	Horizontal	1.5	Pass
587.724	27.4	47	Vertical	2.5	Pass
588.056	39.5	47	Horizontal	1.5	Pass
603.648	33.5	47	Horizontal	1.5	Pass
608.236	39.0	47	Horizontal	1.5	Pass

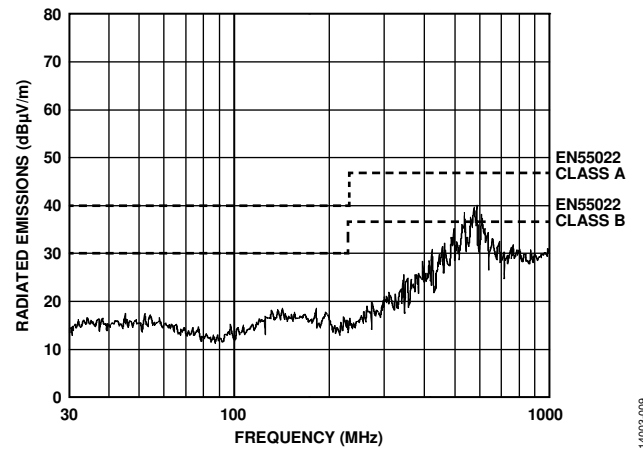
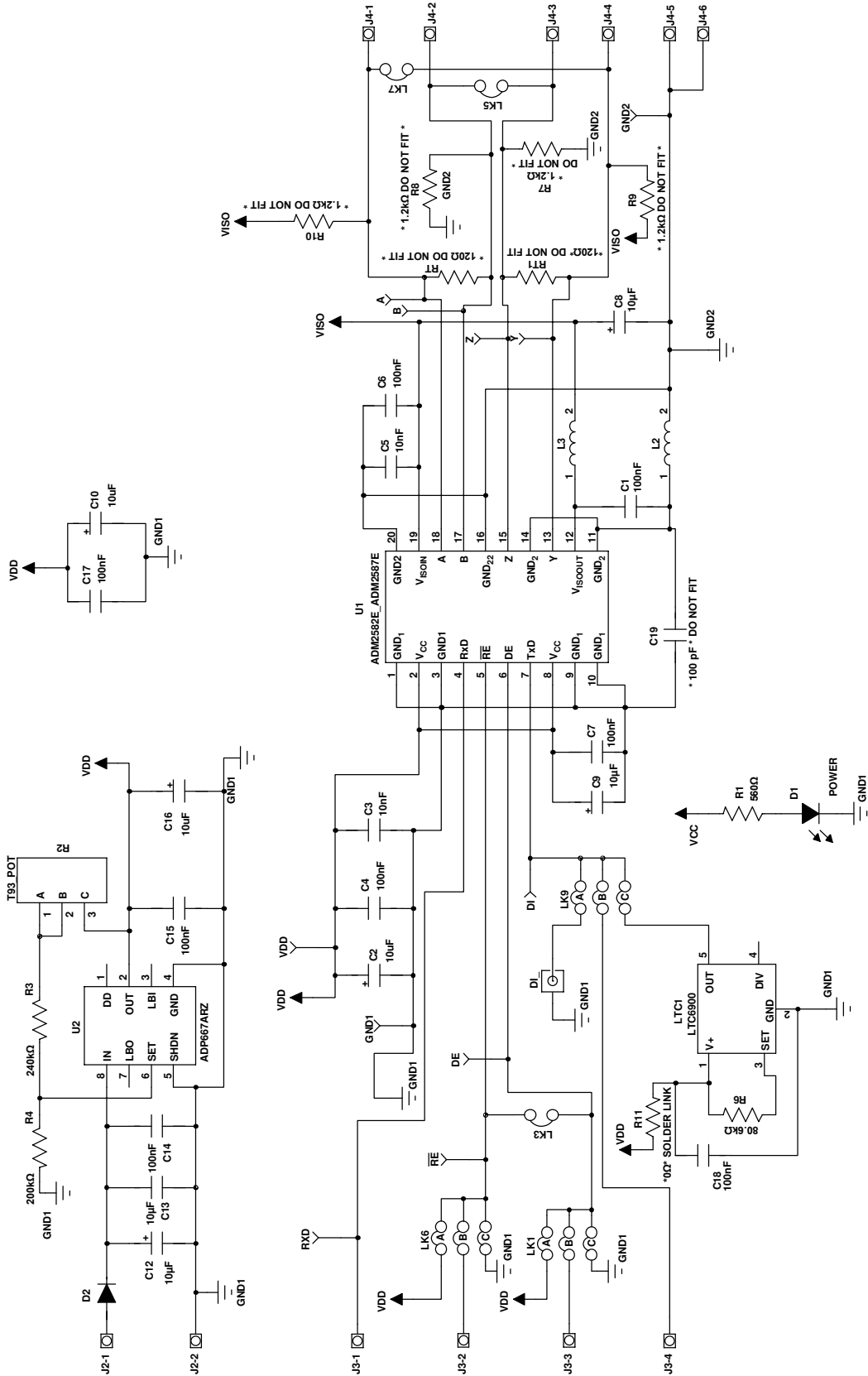

Figure 9. Horizontal Scan from 30 MHz to 1000 MHz (Corresponds to Worst Case for Table 8)

14003-009

EVALUATION BOARD SCHEMATICS AND ARTWORK



14003-010

Figure 10. Schematic of the ADM2582E/ADM2587E Evaluation Board

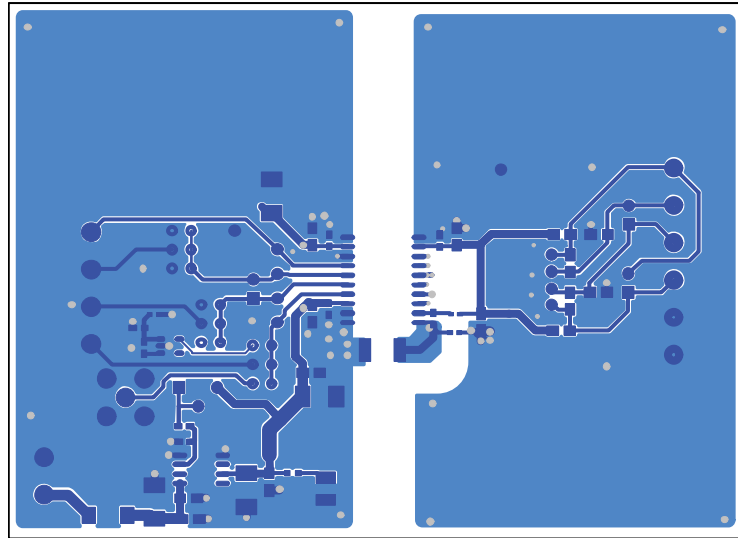

Figure 11. Top Layer

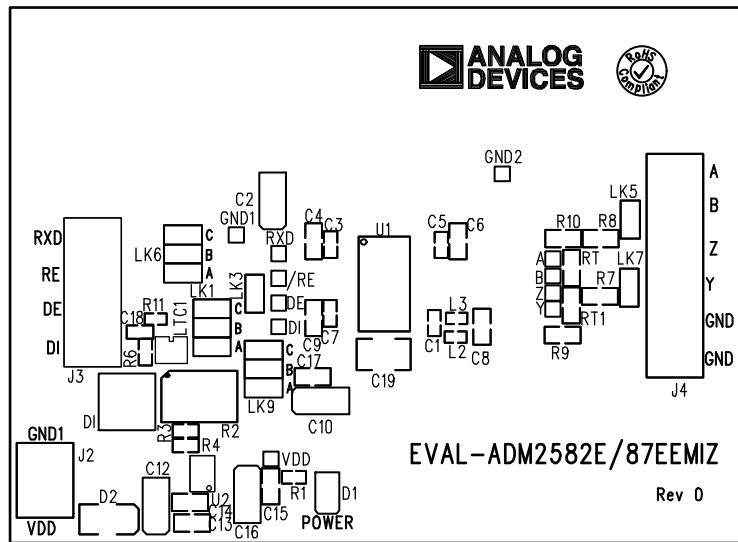

Figure 12. Silkscreen

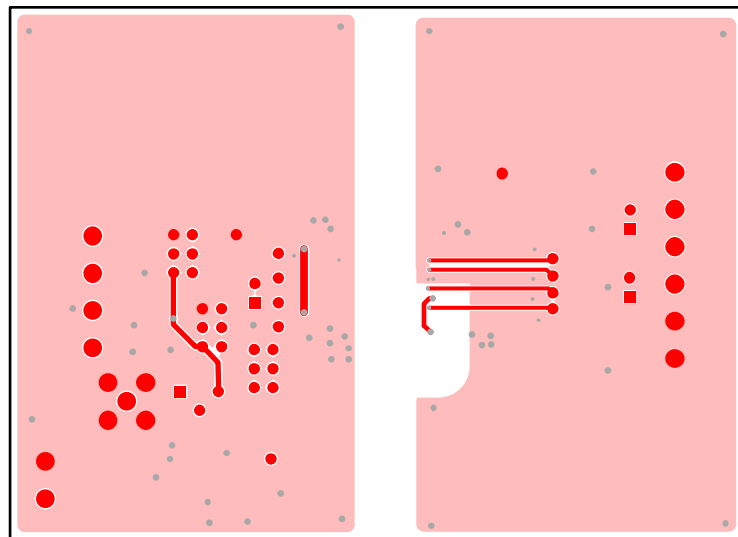

Figure 13. Bottom Layer

ORDERING INFORMATION

BILL OF MATERIALS

Table 9. EVAL-ADM2582EEMIZ

Quantity	Reference Designator	Description	Manufacturer	Part Number
4	RR7, R8, R9, R10	Resistors, size 0805 (not inserted)	Panasonic	ERA6AEB122V
1	R11	Resistor, 0 Ω , size 0402 (not inserted)	Multicomp	MCMR04X000 PTL
1	RT	Resistor, 120 Ω , size 0805 (not inserted)	Yegeo	RC0805JR-07120RL
1	RT1	Resistor, 120 Ω , size 0805 (not inserted)	Yegeo	RC0805JR-07120RL
3	C8, C9, C13	Capacitors, size 0805, 10 μ F	AVX	08056C106KAT2A
5	C4, C6, 14, C15, C17	Capacitors, size 0805, 100 nF	Multicomp	MC0805F104Z160CT
4	C2, C10, C12, C16	Capacitors, tantalum, 10 μ F	Kemet	B45196E3106K309
3	C1, C7, C18	Capacitors, size 0603, 100 nF	Yegeo	CC0603KRX7R7BB104
2	C3, C5	Capacitors, size 0603, 10 nF	AVX	0603YC103KAT2A
1	J2	Power connector, 2-pin terminal block	Camdenboss	CTB5000/2
1	J3	Connector, 4-pin terminal block	Camdenboss	CTB5000/4
1	J4	Connector, 6-pin terminal block	Camdenboss	CTB5000/6
1	LTC1	Oscillator	LTC	LTC6900CS5#TRMPBF
1	R1	Resistor, 0603, 1%, 560R	Multicomp	CRCW0603560RFKEAHP
1	R2	Trimmer, potentiometer, 500 k Ω , 23TURN	Vishay	T93YB504KT20
1	R3	Resistor, 0603, 240 k Ω , 5%	Vishay	CRCW0603240KFKEA
1	R4	Resistor, 0603, 200 k Ω , 5%	Bourns	CR0603-FX-2003ELF
1	R6	Resistor, 0603, 2.49 k Ω , 0.1%	Multicomp	MC0063W060312K49
3	LK1, LK6, LK9	6-pin (3 \times 2), 2.54 mm header and shorting blocks	Harwin	M20-9983646 and M7566-05
3	LK3, LK5, LK7	2-pin (1 \times 2), 2.54 mm header and shorting blocks	Harwin	M20-9990246
1	U1	20-lead, wide body SOIC	Analog Devices, Inc.	ADM2582EBRWZ
1	U2	Adjustable voltage regulator	Analog Devices, Inc.	ADP667ARZ
2	LK2, LK3	Ferrite beads, 0402	Taiyo Yuden	BKH1005LM182-T
1	DI	SMA right hand jack	TE Connectivity	5-1814400-1
1	D1	LED, SMD	Avago	HSMS-C191
1	D2	Schottky diode, 1 A, SMB	ON Semiconductor	MBRS130T3G
1	C19	Capacitor, ceramic, 1812	TDK	C4532C0G3F101K160KA
11	RXD, RE, DE, DI, A, B, Z, Y, VDD, GND1, GND2	Test points, yellow	Vero	20-313140

Table 10. EVAL-ADM2587EEMIZ

Quantity	Reference Designator	Description	Manufacturer	Part Number
4	RR7, R8, R9, R10	Resistors, size 0805 (not inserted)	Panasonic	ERA6AEB122V
1	R11	Resistor, 0 Ω , size 0402 (not inserted)	Multicomp	MCMR04X000 PTL
1	RT	Resistor, 120 Ω , size 0805 (not inserted)	Yegeo	RC0805JR-07120RL
1	RT1	Resistor, 120 Ω , size 0805 (not inserted)	Yegeo	RC0805JR-07120RL
3	C8, C9, C13	Capacitors, size 0805, 10 μ F	AVX	08056C106KAT2A
5	C4, C6, 14, C15, C17	Capacitors, size 0805, 100 nF	Multicomp	MC0805F104Z160CT
4	C2, C10, C12, C16	Capacitors, tantalum, 10 μ F	Kemet	B45196E3106K309
3	C1, C7, C18	Capacitors, size 0603, 100 nF	Yegeo	CC0603KRX7R7BB104
2	C3, C5	Capacitors, size 0603, 10 nF	AVX	0603YC103KAT2A
1	J2	Power connector, 2-pin terminal block	Camdenboss	CTB5000/2
1	J3	Connector, 4-pin terminal block	Camdenboss	CTB5000/4
1	J4	Connector, 6-pin terminal block	Camdenboss	CTB5000/6
1	LTC1	Oscillator	LTC	LTC6900CS5#TRMPBF
1	R1	Resistor, 0603, 1%, 560R	Multicomp	CRCW0603560RFKEAHP
1	R2	Trimmer, POT, 500 k Ω , 23TURN	Vishay	T93YB504KT20
1	R3	Resistor, 0603, 240 k Ω , 5%	Vishay	CRCW0603240KFKEA
1	R4	Resistor, 0603, 200 k Ω , 5%	Bourns	CR0603-FX-2003ELF
1	R6	Resistor, 0603, 2.49 k Ω , 0.1%	TE Connectivity	RP73D1J80K6BTDG
3	LK1, LK6, LK9	6-pin (3 \times 2), 2.54 mm header and shorting blocks	Harwin	M20-9983646 and M7566-05
3	LK3, LK5, LK7	2-pin (1 \times 2), 2.54 mm header and shorting blocks	Harwin	M20-9990246
1	U1	20-lead, wide body SOIC	Analog Devices, Inc.	ADM2587EBRWZ
1	U2	Adjustable voltage regulator	Analog Devices, Inc.	ADP667ARZ
2	LK2, LK3	Ferrite beads, 0402	Taiyo Yuden	BKH1005LM182-T
1	DI	SMA right hand jack	TE Connectivity	5-1814400-1
1	D1	LED, SMD	Avago	HSMS-C191
1	D2	Schottky diode, 1 A, SMB	ON Semiconductor	MBRS130T3G
1	C19	Capacitor, ceramic, 1812	TDK	C4532C0G3F101K160KA
11	RXD, RE, DE, DI, A, B, Z, Y, VDD, GND1, GND2	Test points, yellow	Vero	20-313140

RELATED LINKS

Resource	Description
ADM2587E	500 kbps, 2.5 kV rms signal and power isolated RS-485/RS-422 transceivers with \pm 15 kV ESD Protection
ADM2582E	16 Mbps, 2.5 kV rms signal and power Isolated RS-485/RS-422 transceivers with \pm 15 kV ESD Protection
AN-1349	PCB Implementation Guidelines to Minimize Radiated Emissions on the ADM2582E/ADM2587E RS-485/RS-422 Transceivers
AN-960	RS-485/RS-422 Circuit Implementation Guide
AN-1109	Recommendations for Control of Radiated Emissions with iCoupler [®] Devices

NOTES

**ESD Caution**

ESD (electrostatic discharge) sensitive device. Charged devices and circuit boards can discharge without detection. Although this product features patented or proprietary protection circuitry, damage may occur on devices subjected to high energy ESD. Therefore, proper ESD precautions should be taken to avoid performance degradation or loss of functionality.

Legal Terms and Conditions

By using the evaluation board discussed herein (together with any tools, components documentation or support materials, the "Evaluation Board"), you are agreeing to be bound by the terms and conditions set forth below ("Agreement") unless you have purchased the Evaluation Board, in which case the Analog Devices Standard Terms and Conditions of Sale shall govern. Do not use the Evaluation Board until you have read and agreed to the Agreement. Your use of the Evaluation Board shall signify your acceptance of the Agreement. This Agreement is made by and between you ("Customer") and Analog Devices, Inc. ("ADI"), with its principal place of business at One Technology Way, Norwood, MA 02062, USA. Subject to the terms and conditions of the Agreement, ADI hereby grants to Customer a free, limited, personal, temporary, non-exclusive, non-sublicensable, non-transferable license to use the Evaluation Board FOR EVALUATION PURPOSES ONLY. Customer understands and agrees that the Evaluation Board is provided for the sole and exclusive purpose referenced above, and agrees not to use the Evaluation Board for any other purpose. Furthermore, the license granted is expressly made subject to the following additional limitations: Customer shall not (i) rent, lease, display, sell, transfer, assign, sublicense, or distribute the Evaluation Board; and (ii) permit any Third Party to access the Evaluation Board. As used herein, the term "Third Party" includes any entity other than ADI, Customer, their employees, affiliates and in-house consultants. The Evaluation Board is NOT sold to Customer; all rights not expressly granted herein, including ownership of the Evaluation Board, are reserved by ADI. CONFIDENTIALITY. This Agreement and the Evaluation Board shall all be considered the confidential and proprietary information of ADI. Customer may not disclose or transfer any portion of the Evaluation Board to any other party for any reason. Upon discontinuation of use of the Evaluation Board or termination of this Agreement, Customer agrees to promptly return the Evaluation Board to ADI. ADDITIONAL RESTRICTIONS. Customer may not disassemble, decompile or reverse engineer chips on the Evaluation Board. Customer shall inform ADI of any occurred damages or any modifications or alterations it makes to the Evaluation Board, including but not limited to soldering or any other activity that affects the material content of the Evaluation Board. Modifications to the Evaluation Board must comply with applicable law, including but not limited to the RoHS Directive. TERMINATION. ADI may terminate this Agreement at any time upon giving written notice to Customer. Customer agrees to return to ADI the Evaluation Board at that time. LIMITATION OF LIABILITY. THE EVALUATION BOARD PROVIDED HEREUNDER IS PROVIDED "AS IS" AND ADI MAKES NO WARRANTIES OR REPRESENTATIONS OF ANY KIND WITH RESPECT TO IT. ADI SPECIFICALLY DISCLAIMS ANY REPRESENTATIONS, ENDORSEMENTS, GUARANTEES, OR WARRANTIES, EXPRESS OR IMPLIED, RELATED TO THE EVALUATION BOARD INCLUDING, BUT NOT LIMITED TO, THE IMPLIED WARRANTY OF MERCHANTABILITY, TITLE, FITNESS FOR A PARTICULAR PURPOSE OR NON-INFRINGEMENT OF INTELLECTUAL PROPERTY RIGHTS. IN NO EVENT WILL ADI AND ITS LICENSORS BE LIABLE FOR ANY INCIDENTAL, SPECIAL, INDIRECT, OR CONSEQUENTIAL DAMAGES RESULTING FROM CUSTOMER'S POSSESSION OR USE OF THE EVALUATION BOARD, INCLUDING BUT NOT LIMITED TO LOST PROFITS, DELAY COSTS, LABOR COSTS OR LOSS OF GOODWILL. ADI'S TOTAL LIABILITY FROM ANY AND ALL CAUSES SHALL BE LIMITED TO THE AMOUNT OF ONE HUNDRED US DOLLARS (\$100.00). EXPORT. Customer agrees that it will not directly or indirectly export the Evaluation Board to another country, and that it will comply with all applicable United States federal laws and regulations relating to exports. GOVERNING LAW. This Agreement shall be governed by and construed in accordance with the substantive laws of the Commonwealth of Massachusetts (excluding conflict of law rules). Any legal action regarding this Agreement will be heard in the state or federal courts having jurisdiction in Suffolk County, Massachusetts, and Customer hereby submits to the personal jurisdiction and venue of such courts. The United Nations Convention on Contracts for the International Sale of Goods shall not apply to this Agreement and is expressly disclaimed.