

General Description

The MAX6666/MAX6667 are high-accuracy, low-cost, low-power temperature sensors with a single-wire output. The MAX6666/MAX6667 convert the ambient temperature into a ratiometric PWM output with temperature information contained in the duty cycle of the output square wave. The MAX6666 has a push-pull output and the MAX6667 has an open-drain output.

The MAX6666/MAX6667 operate at supply voltages from +3V to +5.5V. The typical unloaded supply current at 5.0V is 200µA. Both devices feature a single-wire output that minimizes the number of pins necessary to interface with a microprocessor (µP). The output is a square wave with a nominal frequency of 35Hz (±20%) at +25°C. The output format is decoded as follows:

$$\text{Temperature (}^\circ\text{C)} = 235 - (400 \times t_1)/t_2$$

Where t_1 is fixed with a typical value of 10ms and t_2 is modulated by the temperature (Figure 1). The MAX6666/MAX6667 operate from -40°C to +125°C and are available in space-saving SOT23 packages.

Applications

- Process Control
- Industrial
- HVAC and Environmental Control
- µP and µC Temperature Monitoring

Features

- Simple Single-Wire PWM Output
- ±1.0°C Accuracy at +25°C
- High Accuracy
 - ±1°C at $T_A = +30^\circ\text{C}$
 - ±2.5°C at $T_A = +10^\circ\text{C}$ to +50°C
- Operate Up to +125°C
- Low 200µA Typical Current Consumption
- Small SOT23 package

Ordering Information

PART	TEMP RANGE	PIN-PACKAGE	TOP MARK
MAX6666AUT+T	-40°C to +125°C	6 SOT23	AATF
MAX6667AUT+T	-40°C to +125°C	6 SOT23	AATG

+Denotes a lead(Pb)-free/RoHS-compliant package.
T = Tape and reel.

Typical Operating Circuit

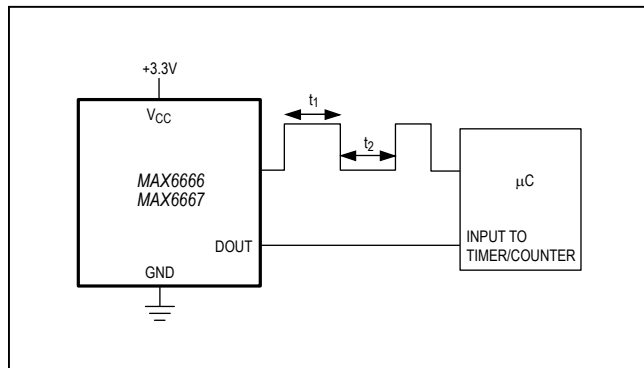

Pin Configuration

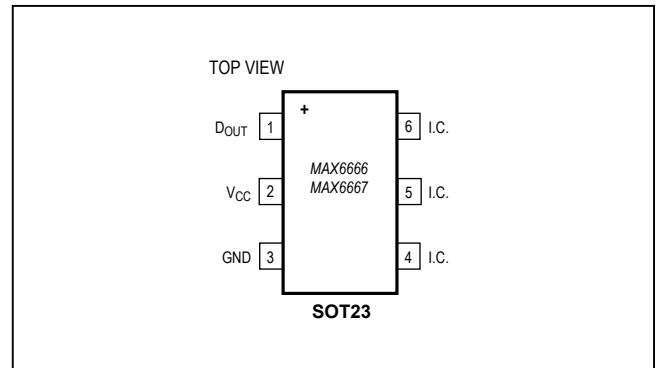

Absolute Maximum Ratings

(Voltages Referenced to GND)

V _{CC}	-0.3V to +6.0V
D _{OUT}	
MAX6666	-0.3V to (V _{CC} + 0.3V)
MAX6667	-0.3V to + 6.0V
D _{OUT} Current	-1mA to +50mA
Continuous Current into Any Other Terminal	±20mA

Continuous Power Dissipation (T_A = +70°C)

6-Pin SOT23 (derate 7.4mW/°C above +70°C)	595mW
Operating Temperature Range	-40°C to +150°C
Storage Temperature Range	-65°C to +150°C
Junction Temperature	+150°C
Lead Temperature (soldering, 10s)	+300°C

Stresses beyond those listed under "Absolute Maximum Ratings" may cause permanent damage to the device. These are stress ratings only, and functional operation of the device at these or any other conditions beyond those indicated in the operational sections of the specifications is not implied. Exposure to absolute maximum rating conditions for extended periods may affect device reliability.

Electrical Characteristics

(V_{CC} = +3.0V to +5.5V, T_A = -40°C to +125°C, unless otherwise noted. Typical values are at V_{CC} = +3.3V, T_A = +25°C.)

PARAMETER	SYMBOL	CONDITIONS	MIN	TYP	MAX	UNITS
Supply Voltage Range	V _{CC}		3.0		5.5	V
Supply Current	I _{CC}	V _{CC} = +3.0V to +5.5V		200	500	μA
Temperature Error		V _{CC} = +3.3V	T _A = +30°C	-1	+1	°C
			T _A = +10°C to +50°C	-2.5	+2.5	
			T _A = 0°C to +100°C	-3.8	+3.8	
			T _A = -25°C to +125°C	-4.8	+4.8	
			T _A = -40°C, V _{CC} = +3.3V	-6	+6	
Nominal t ₁ Pulse Width				10		ms
MAX6666 Output High Voltage		I _{OH} = 800μA	V _{CC} - 0.4			V
MAX6666 Output Low Voltage		I _{OL} = 800μA			0.4	V
MAX6666 Fall Time		C _L = 100pF, R _L = ∞		80		ns
MAX6666 Rise Time		C _L = 100pF, R _L = ∞		80		ns
MAX6667 Output Low Voltage		I _{SINK} = 1.6mA			0.4	V
		I _{SINK} = 5.0mA			1.2	
MAX6667 Fall Time		C _L = 100pF, R _L = 10kΩ		40		ns
MAX6667 Output Capacitance		C _L = 0		15		pF
MAX6667 Output Leakage				<0.1		μA
Power-Supply Rejection Ratio	PSRR	V _{CC} = +3.0V to +5.5V		0.3	1.0	°C/V

Typical Operating Characteristics

(TA = +25°C, unless otherwise noted.)

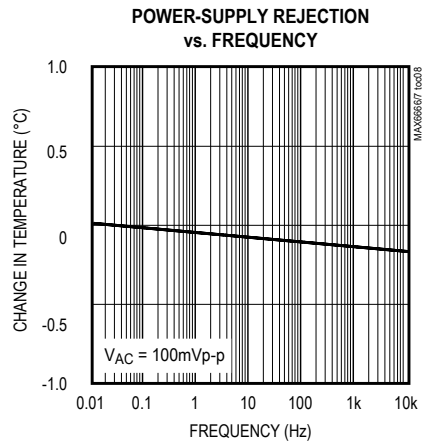
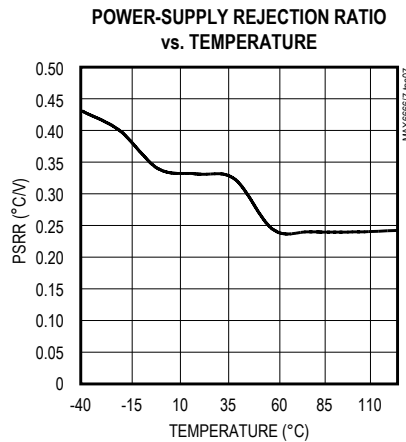
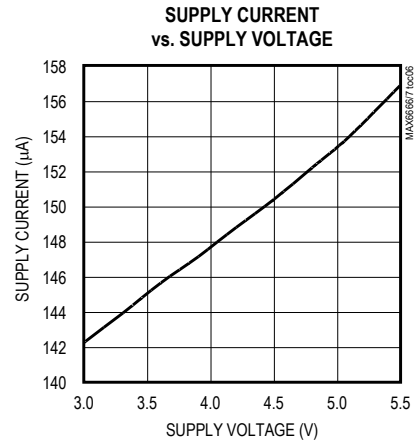
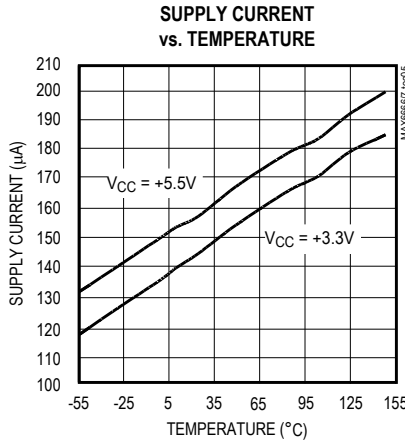
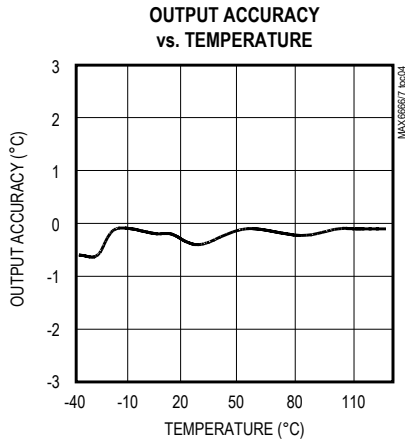
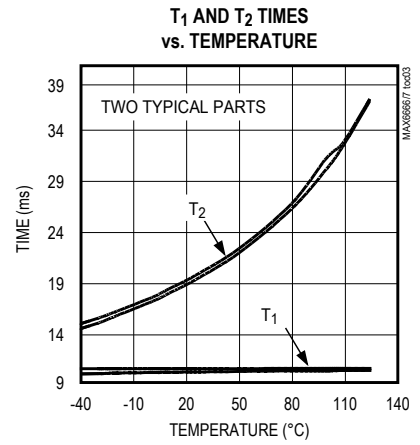
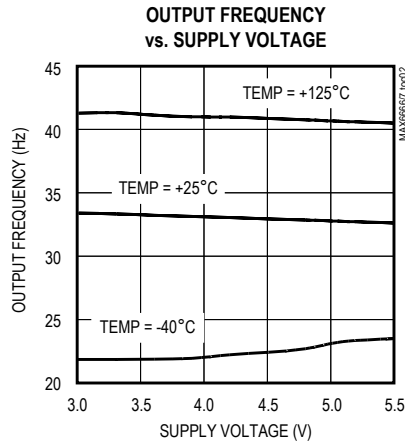
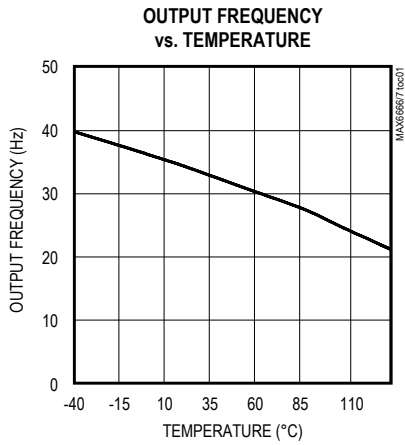

Typical Operating Characteristics (continued)

(TA = +25°C, unless otherwise noted.)

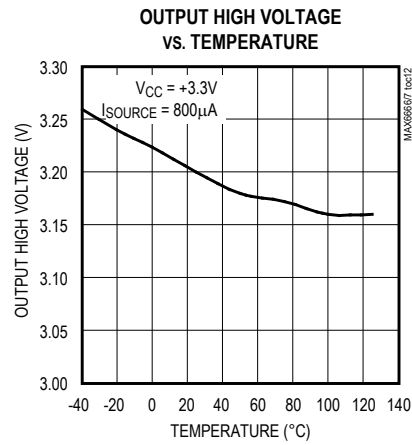
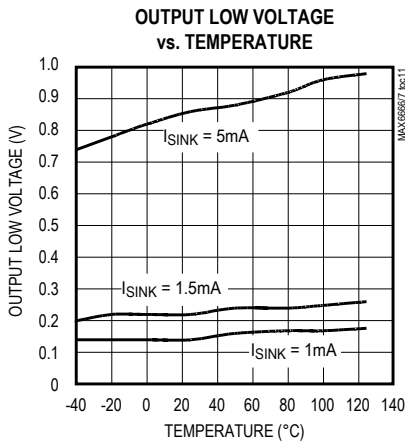
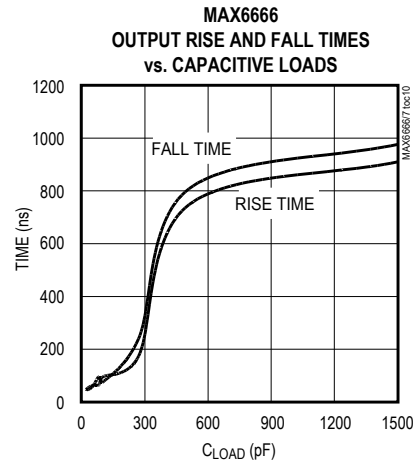
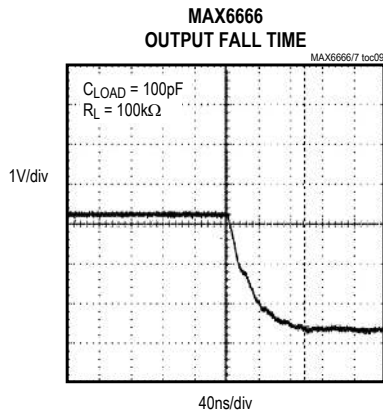

Pin Description

PIN	NAME	FUNCTION
1	D _{OUT}	Digital Output Pin. The pulse width of the output waveform is modulated by the temperature.
2	V _{CC}	Supply Voltage
3	GND	Ground
4, 5, 6	I.C.	Internally Connected. Leave I.C. unconnected or connect to GND.

Detailed Description

The MAX6666/MAX6667 are high-accuracy, low-cost, low current (200µA typ) temperature sensors ideal for interfacing with µCs or µPs. The MAX6666/MAX6667 convert the ambient temperature into a ratiometric PWM output at a nominal frequency of 35Hz (±20%) at +25°C.

The time periods, t_1 (high) and t_2 (low) (Figure 1), are easily read by the µP's timer/counter port. To calculate the temperature, use the expression below:

$$\text{Temperature (}^\circ\text{C)} = +235 - (400 \times t_1)/t_2$$

The µC or µP measures the output of the MAX6666/MAX6667 by counting t_1 and t_2 and computing the temperature based on their ratio. The resolution of the count is a function of the processor clock frequency and the resolution of the counter. The MAX6666/MAX6667 have a resolution of approximately 11 bits. Always use the same clock for t_1 and t_2 counters so that the temperature is strictly based on a ratio of the two times, thus eliminating errors due to different clocks' frequencies.

The MAX6666 (Figure 2a) has a push-pull output and provides rail-to-rail output drive. The ability to source and sink current allows the MAX6666 to drive capacitive loads up to 10nF with less than 1°C error.

The MAX6667 (Figure 2b) has an open-drain output. The output capacitance should be minimized in MAX6667 applications because the sourcing current is set by the pullup resistor. If the output capacitance becomes too large, lengthy rise and fall times distort the pulse width, resulting in inaccurate measurements.

Applications Information

Accurate temperature monitoring requires a good thermal contact between the MAX6666/MAX6667 and the object being monitored. A precise temperature measurement depends on the thermal resistance between the object being monitored and the MAX6666 die. Heat flows in and out of plastic packages primarily through the leads. For the best thermal contact, connect all unused pins to ground. If the sensor is intended to measure the temperature of a heat-generating component on the circuit board, mount the device as close as possible to that component and share the ground traces (if they are not too noisy) with the component. This maximizes the heat transfer from the component to the sensor.

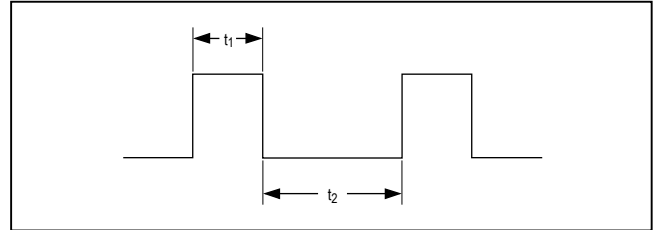

Figure 1. MAX6666/MAX6667 PWM Output

Power-Supply Bypassing

The MAX6666/MAX6667 operate from a +3V to +5.5V supply. If a noisy power-supply line is used, bypass V_{CC} to GND with a 0.1µF capacitor.

Power Supply from µP Port Pin

The low quiescent current of the MAX6666/MAX6667 enables it to be powered from a logic line, which meets the requirements for supply voltage range. This provides a simple shutdown function to totally eliminate quiescent current by taking the logic line low. The logic line must be able to withstand the 0.1µF power-supply bypass capacitance.

Galvanic Isolation

Use an optocoupler to isolate the MAX6666/MAX6667 whenever a high common-mode voltage is present. Because some optocouplers have turn-off times that are much longer than their turn-on times, choose an optocoupler with equal turn-on and turn-off times. Unequal turn-on/turn-off times produce an error in the temperature reading.

Thermal Considerations

Self-heating may cause the temperature measurement accuracy of the MAX6666/MAX6667 to degrade in some applications. The quiescent dissipation and the power dissipated by the digital output may cause errors in obtaining the accurate temperature measurement. The temperature errors depend on the thermal conductivity of the package (SOT23, 140°C/W), the mounting technique, and the airflow. Static dissipation in the MAX6666/MAX6667 is typically 4.5mW operating at 5V with no load. As a worst-case example, consider the MAX6667 and its maximum rated load of 5mA and assume a maximum output voltage of 0.8V adds 4mW power dissipation. Use Figure 3 to estimate the temperature error.

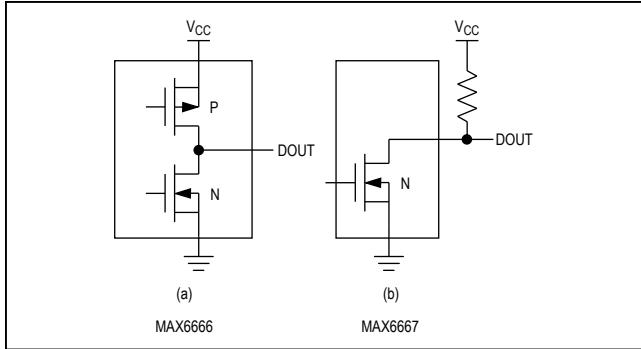

Figure 2. MAX6666/MAX6667 Output Configuration

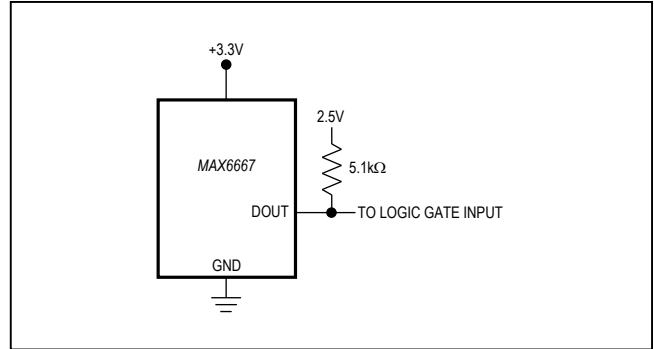

Figure 4. Low-Voltage Logic

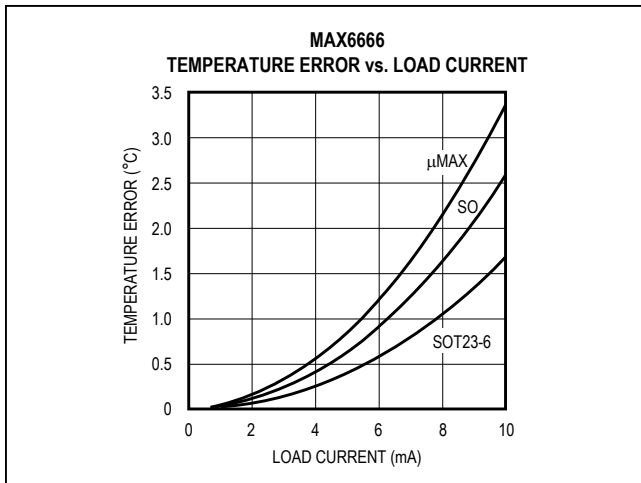

Figure 3. MAX6666 Temperature Error Due to Load Current

Chip Information

PROCESS: BiCMOS

Package Information

For the latest package outline information and land patterns (footprints), go to www.maximintegrated.com/packages. Note that a “+”, “#”, or “-” in the package code indicates RoHS status only. Package drawings may show a different suffix character, but the drawing pertains to the package regardless of RoHS status.

PACKAGE TYPE	PACKAGE CODE	DOCUMENT NO.	LAND PATTERN NO.
6 SOT23	U6FH+6	21-0058	90-0175

Low-Voltage Logic

Use the MAX6667 open-drain output to drive low-voltage devices. As shown in Figure 4, connect a pullup resistor from the low-voltage logic supply to the MAX6667 output. Limit the resistor’s current to about 1mA, thus maintaining an output low logic level of less than 200mV.

Revision History

REVISION NUMBER	REVISION DATE	DESCRIPTION	PAGES CHANGED
3	8/09	Updated <i>Ordering Information</i> , <i>Pin Configuration</i> , <i>Absolute Maximum Ratings</i> , and <i>Pin Description</i> sections	1, 2, 4
4	4/14	Updated <i>Applications</i>	1

For pricing, delivery, and ordering information, please contact Maxim Direct at 1-888-629-4642, or visit Maxim Integrated's website at www.maximintegrated.com.

Maxim Integrated cannot assume responsibility for use of any circuitry other than circuitry entirely embodied in a Maxim Integrated product. No circuit patent licenses are implied. Maxim Integrated reserves the right to change the circuitry and specifications without notice at any time. The parametric values (min and max limits) shown in the Electrical Characteristics table are guaranteed. Other parametric values quoted in this data sheet are provided for guidance.