



WT11

Data Sheet

Version 3.1

Friday, May 22, 2009

Copyright © 2000-2009 Bluegiga Technologies

All rights reserved.

Bluegiga Technologies assumes no responsibility for any errors, which may appear in this manual. Furthermore, Bluegiga Technologies reserves the right to alter the hardware, software, and/or specifications detailed herein at any time without notice, and does not make any commitment to update the information contained herein. Bluegiga Technologies' products are not authorized for use as critical components in life support devices or systems.

The WRAP is a registered trademark of Bluegiga Technologies

The *Bluetooth* trademark is owned by the *Bluetooth* SIG Inc., USA, and is licensed to Bluegiga Technologies.

All other trademarks listed herein are owned by their respective owners.

Contents:

1.	Block Diagram and Descriptions	6
2.	Electrical characteristics	9
3.	WT11 pin description	13
4.	Physical Interfaces	16
4.1	UART Interface.....	16
4.1.1	UART Configuration While RESET is Active	17
4.1.2	UART Bypass Mode.....	17
4.2	USB Interface	19
4.2.1	USB Pull-Up Resistor	19
4.2.2	Self Powered Mode.....	19
4.2.3	Bus Powered Mode	20
4.2.4	Suspend Current.....	21
4.2.5	Detach and Wake-Up Signaling	21
4.2.6	USB Driver.....	22
4.2.7	USB 1.1 Compliance.....	22
4.2.8	USB 2.0 Compatibility.....	22
4.3	SPI Interface	23
4.4	PCM Interface	24
4.4.1	PCM Interface Master/Slave.....	24
4.4.2	Long Frame Sync	25
4.4.3	Short Frame Sync	25
4.4.4	Multi Slot Operation.....	26
4.4.5	GCI Interface	26
4.4.6	Slots and Sample Formats.....	27
4.4.7	Additional Features	28
4.4.8	PCM Configuration.....	28
5.	I/O Parallel Ports	30
6.	Software Stacks.....	31

6.1	iWRAP Stack	31
6.2	HCI Stack	32
6.3	RFCOMM Stack	35
6.4	VM Stack	36
6.5	HID Stack	37
7.	Enhanced Data Rate	39
7.1	Enhanced Data Rate Baseband	39
7.2	Enhanced Data Rate $\Pi/4$ DQPSK	39
7.3	8DQPSK	39
8.	Layout and Soldering Considerations	41
8.1	Soldering recommendations	41
8.2	Layout guidelines	41
9.	WT11 physical dimensions	43
10.	Package	46
11.	Certifications	48
11.1	Bluetooth	48
11.2	FCC	49
11.2.1	FCC antenna designation	50
11.3	CE	51
11.4	Industry Canada (IC)	51
12.	RoHS Statement with a List of Banned Materials	52
13.	Contact Information	53

TERMS & ABBREVIATIONS

Term or Abbreviation:	Explanation:
<i>Bluetooth</i>	Set of technologies providing audio and data transfer over short-range radio connections
<i>CE</i>	Conformité Européene
<i>DFU</i>	Device Firmware Upgrade
<i>EDR</i>	Enhanced Data Rate
<i>FCC</i>	Federal Communications Commission
<i>HCI</i>	Host Controller Interface
<i>HID</i>	Human Interface Device
<i>iWRAP</i>	Interface for WRAP
<i>PCB</i>	Printed Circuit Board
<i>PCM</i>	Pulse Code Modulation
<i>RoHS</i>	The Restriction of Hazardous Substances in Electrical and Electronic Equipment Directive (2002/95/EC)
<i>SPI</i>	Serial Peripheral Interface
<i>UART</i>	Universal Asynchronous Transmitter Receiver
<i>USB</i>	Universal Serial Bus
<i>VM</i>	Virtual Machine
<i>WRAP</i>	Wireless Remote Access Platform

DESCRIPTION

WT11 is a next-generation, class 1, Bluetooth® 2.0+EDR (Enhanced Data Rates) module. It introduces three times faster data rates compared to existing Bluetooth® 1.2 modules even with lower power consumption! WT11 is a highly integrated and sophisticated Bluetooth® module, containing all the necessary elements from Bluetooth® radio to antenna and a fully implemented protocol stack. Therefore WT11 provides an ideal solution for developers who want to integrate Bluetooth® wireless technology into their design with limited knowledge of Bluetooth® and RF technologies.

By default WT11 module is equipped with powerful and easy-to-use iWRAP firmware. iWRAP enables users to access Bluetooth® functionality with simple ASCII commands delivered to the module over serial interface - it's just like a Bluetooth® modem.

FEATURES:

- Fully Qualified Bluetooth system v2.0 + EDR, CE and FCC
- Class 1, range up to 300 meters
- Integrated chip antenna or UFL connector
- Industrial temperature range from -40°C to +85°C
- Enhanced Data Rate (EDR) compliant with v2.0.E.2 of specification for both 2Mbps and 3Mbps modulation modes
- RoHS Compliant
- Full Speed Bluetooth Operation with Full Piconet
- Scatternet Support
- USB interface (USB 2.0 compatible)
- UART with bypass mode
- Support for 802.11 Coexistence
- 8Mbits of Flash Memory

APPLICATIONS:

- Hand held terminals
- Industrial devices
- Point-of-Sale systems
- PCs
- Personal Digital Assistants (PDAs)
- Computer Accessories
- Access Points
- Automotive Diagnostics Units



Figure 1: Physical outlook of WT11-A



Figure 2: Physical outlook of WT11-E

ORDERING INFORMATION:

	Internal chip antenna	UFL connector
iWRAP 3.0 firmware	WT11-A-AI3	WT11-E-AI3
iWRAP 2.2.0 firmware	WT11-A-AI	WT11-E-AI
HCI firmware, BT2.1 + EDR	WT11-A-HCI21	WT11-E-HCI21
HCI firmware, BT2.0 + EDR	WT11-A-HCI	WT11-E-HCI
Custom firmware	WT11-A-C (*)	WT11-E-C (*)

Table 1: Ordering information

*) Custom firmware means any standard firmware with custom parameters (like UART baud rate), custom firmware developed by customer or custom firmware developed by Bluegiga for the customer.

To order custom firmware you must have a properly filled Custom Firmware Order Form and unique ordering code issued by Bluegiga.

Contact support@bluegiga.com for more information.

1. BLOCK DIAGRAM AND DESCRIPTIONS

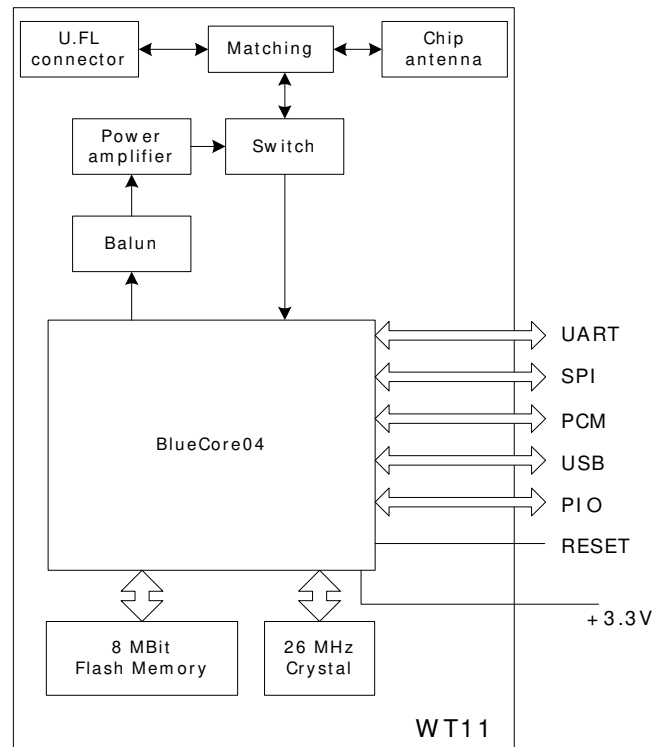

Figure 3: Block Diagram of WT11

BlueCore04

BlueCore04 is a single chip Bluetooth solution which implements the Bluetooth radio transceiver and also an on chip microcontroller. BlueCore04 implements Bluetooth® 2.0+ EDR (Enhanced Data Rate) and it can deliver data rates up to 3 Mbps.

The microcontroller (MCU) on BlueCore04 acts as interrupt controller and event timer run the Bluetooth software stack and control the radio and host interfaces. A 16-bit reduced instruction set computer (RISC) microcontroller is used for low power consumption and efficient use of memory.

BlueCore04 has 48Kbytes of on-chip RAM is provided to support the RISC MCU and is shared between the ring buffers used to hold voice/data for each active connection and the general purpose memory required by the Bluetooth stack.

Crystal

The crystal oscillates at 26MHz.

Flash

Flash memory is used for storing the Bluetooth protocol stack and Virtual Machine applications. It can also be used as an optional external RAM for memory intensive applications.

Balun

Balun changes the balanced input/output signal of the module to unbalanced signal of the monopole antenna.

Power amplifier

Power amplifier is used to increase the output power to a level required by class 1 specification.

Switch

Switch is used to separate transmission and receiver modes.

Matching

Antenna matching components match the antenna to 50 Ohms and also selects between chip antenna and UFL connector.

Antenna

The antenna is ACX AT3216 chip antenna.

U.FL

This is a standard U.FL male connector for external antenna possibility.

USB

This is a full speed Universal Serial Bus (USB) interface for communicating with other compatible digital devices. WT11 acts as a USB peripheral, responding to requests from a Master host controller such as a PC.

Synchronous Serial Interface

This is a synchronous serial port interface (SPI) for interfacing with other digital devices. The SPI port can be used for system debugging. It can also be used for programming the Flash memory.

UART

This is a standard Universal Asynchronous Receiver Transmitter (UART) interface for communicating with other serial devices.

Audio PCM Interface

The audio pulse code modulation (PCM) Interface supports continuous transmission and reception of PCM encoded audio data over Bluetooth.

Programmable I/O

WT11 has a total of 6 digital programmable I/O terminals. These are controlled by firmware running on the device.

Reset

This can be used to reset WT11.

802.11 Coexistence Interface

Dedicated hardware is provided to implement a variety of coexistence schemes. Channel skipping AFH (Adaptive Frequency Hopping), priority signaling, channel signaling and host passing of channel instructions are all supported. The features are configured in firmware. Since the details of some methods are proprietary (e.g. Intel WCS) please contact Bluegiga Technologies for details.

2. ELECTRICAL CHARACTERISTICS

Absolute maximum ratings

	Min	Max	Unit
Storage temperature	-40	85	°C
Operating temperature	-40	85	°C
Supply voltage	-0,3	3,6	V
Terminal voltages	-0,4	Vdd + 0,4	V
Output current from PIOs		35	mA

The module should not continuously run under these conditions. Exposure to absolute maximum rating conditions for extended periods of time may affect reliability and cause permanent damage to the device.

Table 2: Absolute maximum ratings

Recommended operating conditions

	Min	Max	Unit
Operating temperature	-40	85	°C
Supply voltage	3,1 ⁽¹⁾⁽²⁾	3.6	V
Terminal voltages	0	Vdd	V

Table 3: Recommended operating conditions

- 1) WT11 operates as low as 2,7 V supply voltage. However, to safely meet the USB specification for minimum voltage for USB data lines, minimum of 3,1 V supply is required.
- 2) The supply voltage has an effect on the output power of WT11. See figure 4.

Terminal characteristics

	Min	Typ	Max	Unit
I/O voltage levels				
V _{IL} input logic level low	-0,4	-	0,8	V
V _{IH} input logic level high	0,7Vdd	-	Vdd + 0,4	V
V _{OL} output logic level low	-	-	0,2	V
V _{OH} output logic level high	Vdd - 0,2	-	-	V
Reset terminal				
V _{TH,res} threshold voltage	0,64	0,85	1,5	V
R _{IRES} input resistance		220		kΩ
C _{IRES} input capacitance		220		nF
Input and tri-state current with				
Strong pull-up	-100	-40	-10	μA
Strong pull-down	10	40	100	μA
Weak pull-up	-5	-1	-0,2	μA
Weak pull-down	0,2	1	5	μA
I/O pad leakage current	-1	0	1	μA
Vdd supply current				
TX mode	-	-	170	mA
RX mode	-	-	170	mA

Table 4: Terminal characteristics

Current consumption

Test conditions: Room temperature, Vdd = 3,3 V, iWRAP firmware

OPERATION MODE	Peak supply current	AVG supply current	Unit	Notes
Peak current at TX mode	170	-	mA	-
Peak current at RX mode	170	-	mA	-
IDLE	-	3	mA	Module is idle Default settings
IDLE, Deep Sleep ON	-	1,5	mA	Module is idle
IDLE, Deep Sleep ON NOT visible, NOT connectable	-	0,37	mA	Module is idle Minimum consumption
INQUIRY	-	54,6	mA	Device discovery with INQUIRY command
NAME	-	54,6	mA	Name resolution
CALL [channel]	-	54,6	mA	CALL addr 1 RFCOMM, Default settings
CALL [UUID]	-	54,7	mA	CALL addr 1101 RFCOMM, Default settings
CONNECT Slave	-	21,5	mA	No data was transmitted, Default settings
CONNECT Master	-	6,5	mA	No data was transmitted, Default settings
CONNECT, Slave Sniff mode ON	-	3,7	mA	No data was transmitted, Default settings, Sniff parameter 1000
CONNECT, Master Sniff mode ON	-	4,9	mA	No data was transmitted, Default settings, Sniff parameter 1000
CONNECT, Slave Park mode ON	-	3,4	mA	No data was transmitted, Default settings, Park parameter 1000
CONNECT. Master Park mode ON	-	6,3	mA	No data was transmitted, Default settings, Park parameter 1000
CONNECT + DataSlave (RX)	-	33,4	mA	UART: 115200,8n1, Full bandwidth transmission, Default settings, 2 meter distance
CONNECT + DataMaster (TX)	-	22,0	mA	UART: 115200,8n1, Full bandwidth transmission, Default settings, 2 meter distance
CONNECT + DataSlave (RX) Sniff mode ON	-	23,8	mA	UART: 115200,8n1, Sniff parameter 40, Full bandwidth transmission, 1 meter distance
CONNECT + DataMaster (TX) Sniff mode ON	-	18,3	mA	UART: 115200,8n1, Sniff parameter 40, Full bandwidth transmission, 1 meter distance

Table 5: Current consumption

Radio characteristics and general specifications

	Specification		Note
Operating frequency range	(2400 ... 2483,5) MHz		ISM Band
Lower guard band	2 MHz		
Upper guard band	3,5 MHz		
Carrier frequency	2402 MHz ... 2480 MHz		$f = 2402 + k$, $k = 0...78$
Modulation method	GFSK (1 Mbps) P/4 DQPSK (2Mbps)		
Hopping	1600 hops/s, 1 MHz channel space		
Maximum data rate	GFSK:	Asynchronous, 723.2 kbps / 57.6 kbps Synchronous: 433.9 kbps / 433.9 kbps	
	P/4 DQPSK:	Asynchronous, 1448.5 kbps / 115.2 kbps Synchronous: 869.7 kbps / 869.7 kbps	
	8DQPSK:	Asynchronous, 2178.1 kbps / 177.2 kbps Synchronous: 1306.9 kbps / 1306.9 kbps	
Receiving signal range	-82 to -20 dBm		Typical condition
Receiver IF frequency	1.5 MHz		Center frequency
Transmission power	Min	-11 ... -9 dBm	
	Max	+14 ... +18 dBm	
RF input impedance	50 Ω		
Compliance	Bluetooth specification, version 2.0 + EDR		
USB specification	USB specification, version 1.1 (USB 2.0 compliant)		

Table 6: Radio characteristics and general specifications

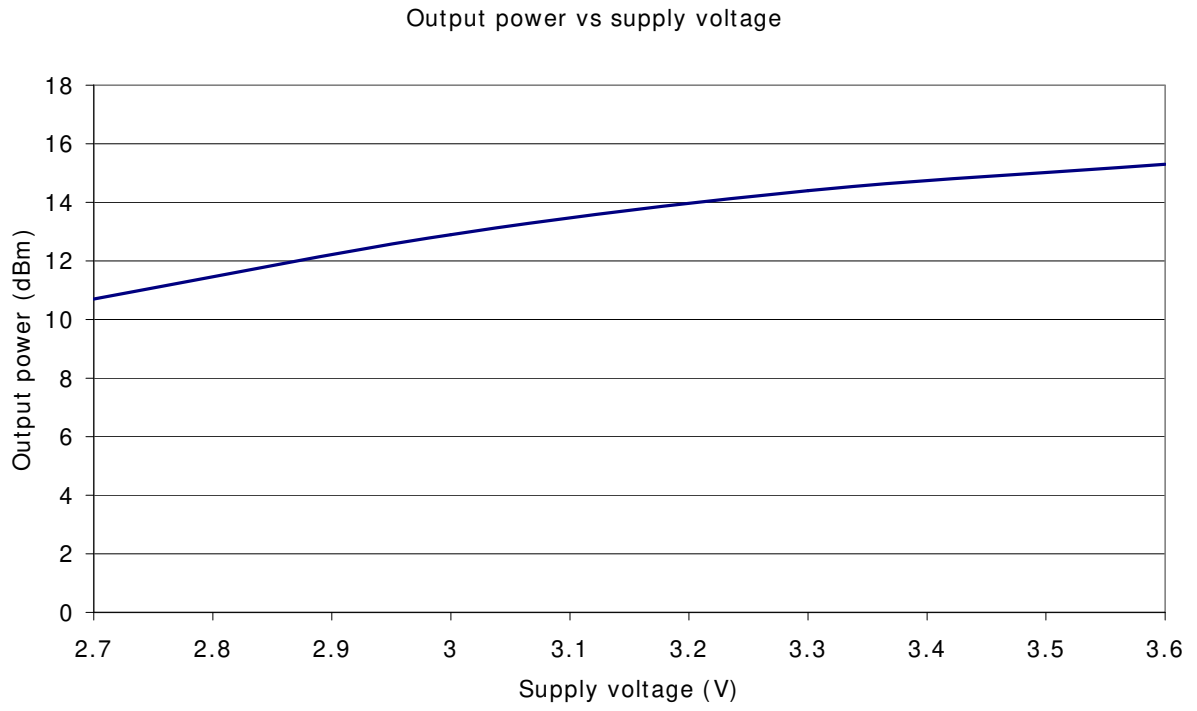

Figure 4: WT11 output power vs supply voltage

3. WT11 PIN DESCRIPTION

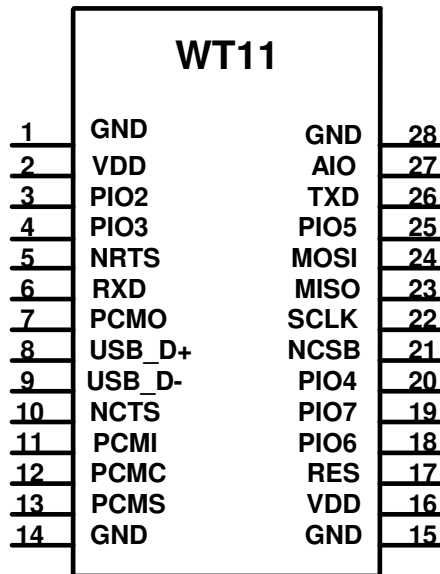

Figure 5: WT11 connection diagram

GND (pins 1, 14, 15 and 28)

Connect GND pins to the ground plane of PCB.

VDD (pins 2 and 16)

3.3 V supply voltage connection. WT11 has an internal decoupling capacitor and LC filter to block high frequency disturbances. Thus external filtering is usually not needed. It is however recommended to leave an option for an external high Q 10pF decoupling capacitor in case EMC problems arise.

RES (pin 17)

The RESET pin is an active high reset and is internally filtered using the internal low frequency clock oscillator. A reset will be performed between 1.5 and 4.0ms following RESET being active. It is recommended that RESET be applied for a period greater than 5ms.

WT11 has an internal reset circuitry, which keeps reset pin active until supply voltage has reached stability in the start up. This ensures that supply for the flash memory inside the WT11 will reach stability before BC4 chip fetches instructions from it. Schematic of the reset circuitry is shown in figure 5. Rising supply voltage charges the capacitor, which will activate the reset of WT11. The capacitor discharges through 220 kΩ resistor, which eventually deactivates the reset. Time constant of the RC circuitry is set such that the supply voltage is safely stabilized before reset deactivates. Pull-up or pull-down resistor should not be connected to the reset pin to ensure proper star up of WT11.

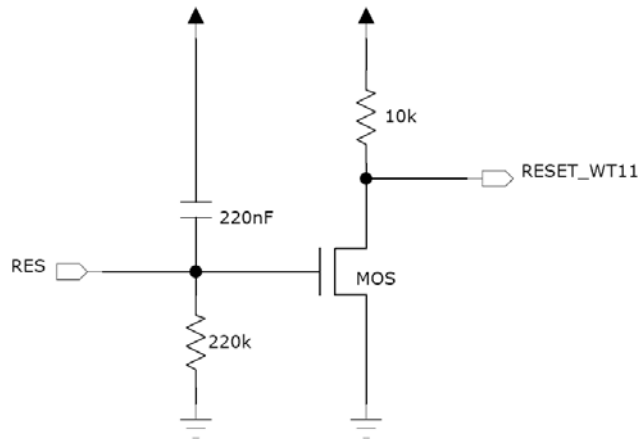

Figure 6: WT11 internal reset circuitry

PIO2 – PIO7 (pins 3, 4, 18, 19, 20 and 25)

Programmable digital I/O lines. All PIO lines can be configured through software to have either weak or strong pull-ups or pull-downs. Configuration for each PIO line depends on the application. See section 10 “I/O parallel ports” for detailed descriptions for each terminal. Default configuration for all of the PIO lines is input with weak internal pull-up.

AIO (pin 27)

General purpose analog interface. Typically used for battery voltage measurements. Can be left not connected.

NRTS (pin 5)

CMOS output with weak internal pull-up. Can be used to implement RS232 hardware flow control where RTS (request to send) is active low indicator. UART interface requires external RS232 transceiver chip.

NCTS (pin 10)

CMOS input with weak internal pull-down. Can be used to implement RS232 hardware flow control where CTS (clear to send) is active low indicator. UART interface requires external RS232 transceiver chip.

RXD (pin 6)

CMOS input with weak internal pull-down. RXD is used to implement UART data transfer from another device to WT11. UART interface requires external RS232 transceiver chip.

TXD (pin 26)

CMOS output with weak internal pull-up. TXD is used to implement UART data transfer from WT11 to another device. UART interface requires external RS232 transceiver chip.

PCMO (pin 7)

CMOS output with weak internal pull-down. Used in PCM (pulse code modulation) interface to transmit digitized audio.

PCMI (pin 11)

CMOS input with weak internal pull-down. Used in PCM interface to receive digitized audio.

PCMC (pin 12)

Bi-directional synchronous data clock signal pin with weak internal pull-down. PCMC is used in PCM interface to transmit or receive CLK signal. When configured as a master, WT11 generates clock signal for the PCM interface. When configured as a slave PCMC is an input and receives the clock signal from another device.

PCMS (pin 13)

Bi-directional synchronous data strobe with weak internal pull-down. When configured as a master, WT11 generates SYNC signal for the PCM interface. When configured as a slave PCMS is an input and receives the SYNC signal from another device.

USB_D+ (pin 8)

Bi-directional USB data line with a selectable internal 1.5 k Ω pull-up implemented as a current source (compliant with USB specification v1.2). External series resistor is required to match the connection to the characteristic impedance of the USB cable.

USB_D- (pin 9)

Bi-directional USB data line. External series resistor is required to match the connection to the characteristic impedance of the USB cable.

NCSB (pin 21)

CMOS input with weak internal pull-up. Active low chip select for SPI (serial peripheral interface).

SCLK (pin 22)

CMOS input for the SPI clock signal with weak internal pull-down. WT11 is the slave and receives the clock signal from the device operating as a master.

MISO (pin 23)

SPI data output with weak internal pull-down.

MOSI (pin 24)

SPI data input with weak internal pull-down.

4. PHYSICAL INTERFACES

4.1 UART Interface

WT11 Universal Asynchronous Receiver Transmitter (UART) interface provides a simple mechanism for communicating with other serial devices using the RS232 standard. The UART interface of WT11 uses voltage levels of 0 to V_{dd} and thus external transceiver IC is required to meet the voltage level specifications of UART.

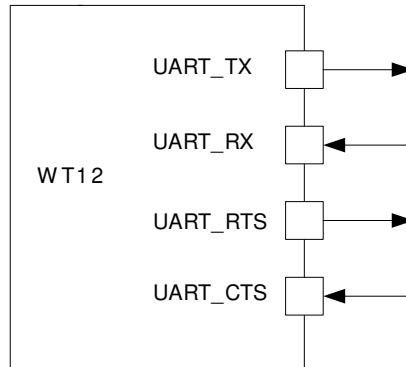

Figure 7: WT11 UART interface

Four signals are used to implement the UART function, as shown in Figure 7. When WT11 is connected to another digital device, UART_RX and UART_TX transfer data between the two devices. The remaining two signals, UART_CTS and UART_RTS, can be used to implement RS232 hardware flow control where both are active low indicators. DTR, DSR and DCD signals can be implemented using PIO terminals of WT11. All UART connections are implemented using CMOS technology and have signaling levels of 0V and V_{DD}.

In order to communicate with the UART at its maximum data rate using a standard PC, an accelerated serial port adapter card is required for the PC.

Parameter		Possible values
Baud rate	Minimum	1200 baud (d2%Error)
	Maximum	9600 baud (d1%Error)
Flow control		RTS/CTS, none
Parity		None, Odd, Even
Number of stop bits		1 or 2
Bits per channel		8

Table 7: Possible UART settings

The UART interface is capable of resetting WT11 upon reception of a break signal. A Break is identified by a continuous logic low (0V) on the UART_RX terminal, as shown in Figure 8. If t_{BRK} is longer than the value, defined by the PS Key PSKEY_HOST_IO_UART_RESET_TIMEOUT, (0x1a4), a reset will occur. This feature allows a host to initialize the system to a known state. Also, WT11 can emit a Break character that may be used to wake the Host.

Since UART_RX terminal includes weak internal pull-down, it can't be left open unless disabling UART interface using PS_KEY settings. If UART is not disabled, a pull-up resistor

has to be connected to UART_RX. UART interface requires external RS232 transceiver, which usually includes the required pull-up.

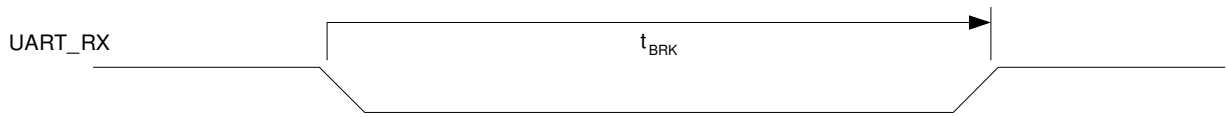

Figure 8: Break signal

Note:

Table 8 shows a list of commonly used Baud rates and their associated values for the Persistent Store Key PSKEY_UART_BAUD_RATE (0x204). There is no requirement to use these standard values. Any Baud rate within the supported range can be set in the Persistent Store Key according to the formula in Equation below.

$$\text{Baud Rate} = \frac{\text{PSKEY_UART_BAUD_RATE}}{0.004096}$$

Figure 9: Baud rate calculation formula

Baud rate	Persistent store values		Error
	Hex	Dec	
1200	0x0005	5	1.73%
2400	0x000a	10	1.73%
4800	0x0014	20	1.73%
9600	0x0027	39	-0.82%
19200	0x004f	79	0.45%
38400	0x009d	157	-0.18%
57600	0x00ec	263	0.03%
76800	0x013b	315	0.14%
115200	0x01d8	472	0.03%
230400	0x03b0	944	0.03%
460800	0x075f	1887	-0.02%
921600	0x0ebf	3775	0.00%
1382400	0x161e	5662	-0.01%
1843200	0x1d7e	7550	0.00%
2765800	0x2c3d	11325	0.00%

Table 8: UART baud rates and error values

4.1.1 UART Configuration While RESET is Active

The UART interface for WT11 while the chip is being held in reset is tri-state. This will allow the user to daisy chain devices onto the physical UART bus. The constraint on this method is that any devices connected to this bus must tri-state when WT11reset is de-asserted and the firmware begins to run.

4.1.2 UART Bypass Mode

Alternatively, for devices that do not tri-state the UART bus, the UART bypass mode on WT11 can be used. The default state of WT11 after reset is de-asserted, this is for the host

UART bus to be connected to the WT11 UART, thereby allowing communication to WT11 via the UART.

In order to apply the UART bypass mode, a BCCMD command will be issued to WT11 upon this, it will switch the bypass to PIO[7:4] as shown in Figure 10. Once the bypass mode has been invoked, WT11 will enter the deep sleep state indefinitely.

In order to re-establish communication with WT11, the chip must be reset so that the default configuration takes affect.

It is important for the host to ensure a clean Bluetooth disconnection of any active links before the bypass mode is invoked. Therefore it is not possible to have active Bluetooth links while operating the bypass mode.

The current consumption for a device in UART Bypass Mode is equal to the values quoted for a device in standby mode.

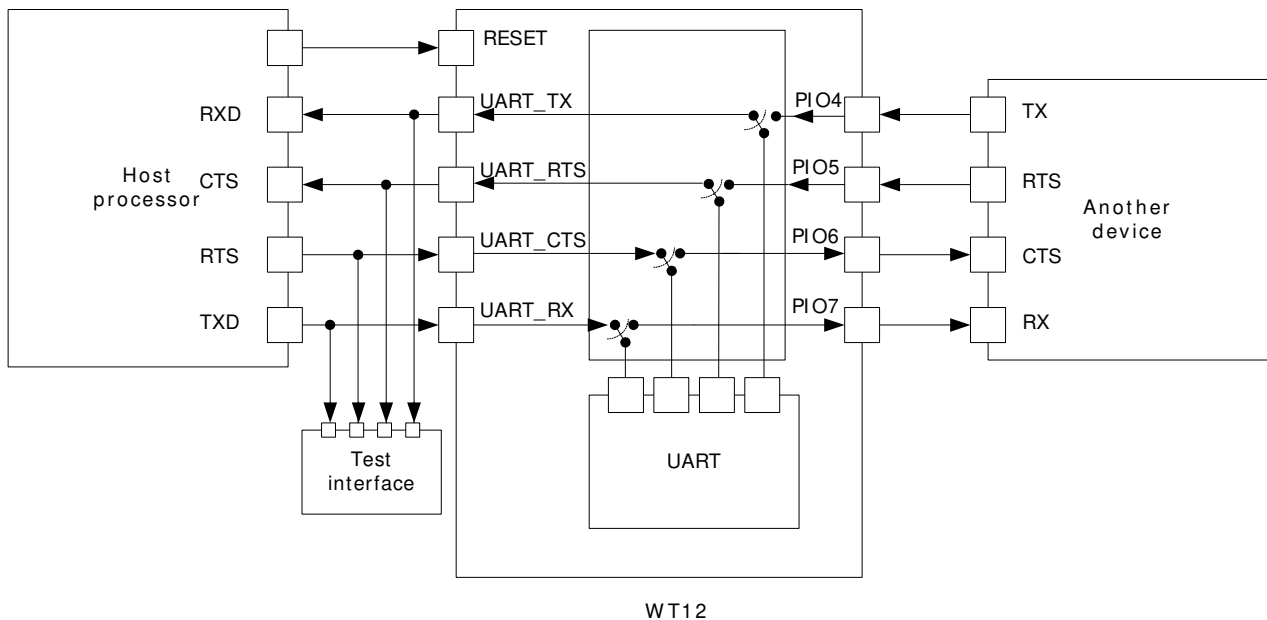

Figure 10: UART bypass mode

4.2 USB Interface

WT11 USB devices contain a full speed (12Mbits/s) USB interface that is capable of driving a USB cable directly. No external USB transceiver is required. To match the connection to the characteristic impedance of the USB cable, series resistors must be included to both of the signal lines. These should be of 1% tolerance and the value required may vary between 0 and 20 ohm with 10 ohm being nominal. The resistors should be placed close to the USB pins of the module in order to avoid reflections. The module has internally 22 ohm resistors in series. The total input impedance seen by the cable is affected by the IC characteristics, track layout and the connector. The cable impedance is approximately 40 ohm.

The device operates as a USB peripheral, responding to requests from a master host controller such as a PC. Both the OHCI and the UHCI standards are supported. The set of USB endpoints implemented can behave as specified in the USB section of the Bluetooth v2.0 + EDR specification or alternatively can appear as a set of endpoint appropriate to USB audio devices such as speakers.

As USB is a Master/Slave oriented system (in common with other USB peripherals), WT11 only supports USB Slave operation.

4.2.1 USB Pull-Up Resistor

WT11 features an internal USB pull-up resistor. This pulls the USB_DP pin weakly high when WT11 is ready to enumerate. It signals to the PC that it is a full speed (12Mbit/s) USB device.

The USB internal pull-up is implemented as a current source, and is compliant with Section 7.1.5 of the USB specification v1.2. The internal pull-up pulls USB_D+ high to at least 2.8V when loaded with a 15k Ω +/-5% pull-down resistor (in the hub/host). This presents a Therein resistance to the host of at least 900 Ω . Alternatively, an external 1.5k Ω pull-up resistor can be placed between a PIO line and D+ on the USB cable. The firmware must be alerted to which mode is used by setting PS Key PSKEY_USB_PIO_PULLUP appropriately. The default setting uses the internal pull-up resistor.

4.2.2 Self Powered Mode

In self powered mode, the circuit is powered from its own power supply and not from the VBUS (5V) line of the USB cable. It draws only a small leakage current (below 0.5mA) from VBUS on the USB cable. This is the easier mode for which to design for, as the design is not limited by the power that can be drawn from the USB hub or root port. However, it requires that VBUS be connected to WT11 via a voltage divider (Rvb1 and Rvb2), so WT11 can detect when VBUS is powered up. Voltage divider is essential to drop the 5V voltage at the VBUS to 3,3V expected at the USB interface of WT11. WT11 will not pull USB_DP high when VBUS is off.

Self powered USB designs (powered from a battery or PSU) must ensure that a PIO line is allocated for USB pull-up purposes. A 1.5K 5% pull-up resistor between USB_DP and the selected PIO line should be fitted to the design. Failure to fit this resistor may result in the design failing to be USB compliant in self powered mode. The internal pull-up in WT11 is only suitable for bus powered USB devices i.e. dongles.

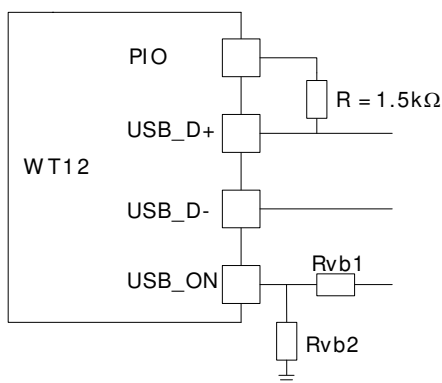

Figure 11: USB in self powered mode

The terminal marked USB_ON can be any free PIO pin. The PIO pin selected must be registered by setting PSKEY_USB_PIO_VBUS to the corresponding pin number. In self powered mode PSKEY_USB_PIO_PULLUP must be set to match with the PIO selected.

Note:

USB_ON is shared with WT11 PIO terminals (PIO2-PIO7).

4.2.3 Bus Powered Mode

In bus powered mode the application circuit draws its current from the 5V VBUS supply on the USB cable. WT11 negotiates with the PC during the USB enumeration stage about how much current it is allowed to consume.

For WT11 Bluetooth applications, it is recommended that the regulator used to derive 3.3V from VBUS is rated at 200mA average current and should be able to handle peaks of 220mA without fold back or limiting. In bus powered mode, WT11 requests 200mA during enumeration.

When selecting a regulator, be aware that VBUS may go as low as 4.4V. The inrush current (when charging reservoir and supply decoupling capacitors) is limited by the USB specification (see USB specification v1.1, Section 7.2.4.1). Some applications may require soft start circuitry to limit inrush current if more than 10pF is present between VBUS and GND.

The 5V VBUS line emerging from a PC is often electrically noisy. As well as regulation down to 3.3V, applications should include careful filtering of the 5V line to attenuate noise that is above the voltage regulator bandwidth.

In bus powered mode PSKEY_USB_PIO_PULLUP must be set to 16 for internal pull-up (default configuration in WT11).

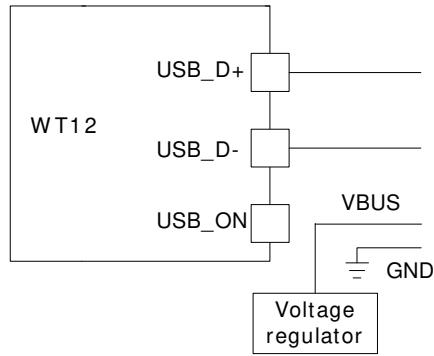

Figure 12: USB in bus powered mode

4.2.4 Suspend Current

All USB devices must permit the USB controller to place them in a USB Suspend mode. While in USB Suspend, bus powered devices must not draw more than 0.5mA from USB VBUS (self powered devices may draw more than 0.5mA from their own supply). This current draw requirement prevents operation of the radio by bus powered devices during USB Suspend.

The voltage regulator circuit itself should draw only a small quiescent current (typically less than 100uA) to ensure adherence to the suspend current requirement of the USB specification. This is not normally a problem with modern regulators. Ensure that external LEDs and/or amplifiers can be turned off by WT11. The entire circuit must be able to enter the suspend mode. (For more details on USB Suspend, see separate CSR documentation).

4.2.5 Detach and Wake-Up Signaling

WT11 can provide out-of-band signaling to a host controller by using the control lines called 'USB_DETACH' and 'USB_WAKE_UP'. These are outside the USB specification (no wires exist for them inside the USB cable), but can be useful when embedding WT11 into a circuit where no external USB is visible to the user. Both control lines are shared with PIO pins and can be assigned to any PIO pin by setting the PS Keys PSKEY_USB_PIO_DETACH and PSKEY_USB_PIO_WAKEUP to the selected PIO number.

USB_DETACH is an input which, when asserted high, causes WT11 to put USB_D- and USB_D+ in high impedance state and turned off the pull-up resistor on D+. This detaches the device from the bus and is logically equivalent to unplugging the device. When USB_DETACH is taken low, WT11 will connect back to USB and await enumeration by the USB host.

USB_WAKE_UP is an active high output (used only when USB_DETACH is active) to wake up the host and allow USB communication to recommence. It replaces the function of the software USB_WAKE_UP message (which runs over the USB cable), and cannot be sent while WT11 is effectively disconnected from the bus.

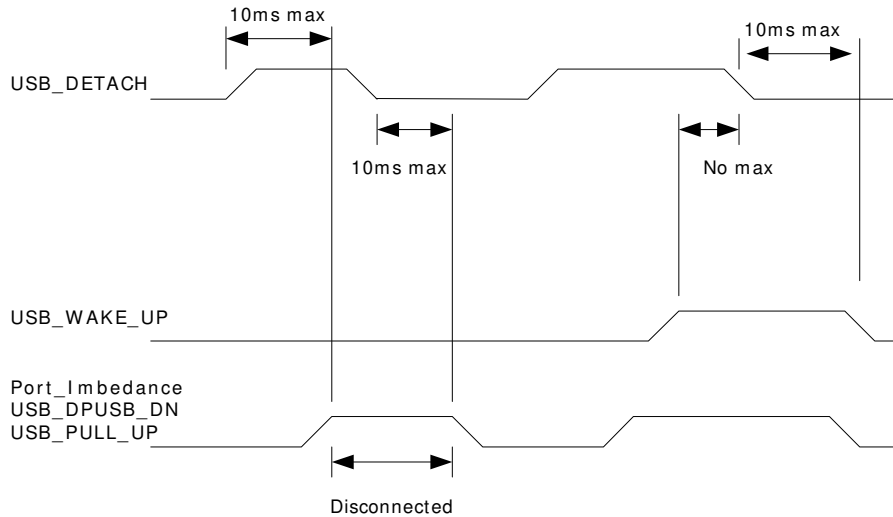

Figure 13: USB_DETACH and USB_WAKE_UP Signal

4.2.6 USB Driver

A USB Bluetooth device driver is required to provide a software interface between WT11 and Bluetooth software running on the host computer. Suitable drivers are available from www.bluegiga.com/techforum/.

4.2.7 USB 1.1 Compliance

WT11 is qualified to the USB specification v1.1, details of which are available from <http://www.usb.org>. The specification contains valuable information on aspects such as PCB track impedance, supply inrush current and product labeling.

Although WT11 meets the USB specification, Bluegiga Technologies cannot guarantee that an application circuit designed around the module is USB compliant. The choice of application circuit, component choice and PCB layout all affect USB signal quality and electrical characteristics. The information in this document is intended as a guide and should be read in association with the USB specification, with particular attention being given to Chapter 7. Independent USB qualification must be sought before an application is deemed USB compliant and can bear the USB logo. Such qualification can be obtained from a USB plug fest or from an independent USB test house.

Terminals USB_D+ and USB_D- adhere to the USB specification 2.0 (Chapter 7) electrical requirements.

4.2.8 USB 2.0 Compatibility

WT11 is compatible with USB v2.0 host controllers; under these circumstances the two ends agree the mutually acceptable rate of 12Mbits/s according to the USB v2.0 specification.

4.3 SPI Interface

The synchronous serial port interface (SPI) is for interfacing with other digital devices. The SPI port can be used for system debugging. It can also be used for programming the Flash memory. SPI interface is connected using the MOSI, MISO, CSB and CLK pins.

The module operates as a slave and thus MISO is an output of the module. MISO is not in high-impedance state when CSB is pulled high. Instead, the module outputs 0 if the processor is running and 1 if it is stopped. Thus WT11 should not be connected in a multi-slave arrangement by simple parallel connection of slave MISO lines.

4.4 PCM Interface

Pulse Code Modulation (PCM) is a standard method used to digitize audio (particularly voice) patterns for transmission over digital communication channels. Through its PCM interface, WT11 has hardware support for continual transmission and reception of PCM data, thus reducing processor overhead for wireless headset applications. WT11 offers a bi directional digital audio interface that routes directly into the baseband layer of the on chip firmware. It does not pass through the HCI protocol layer.

Hardware on WT11 allows the data to be sent to and received from a SCO connection. Up to three SCO connections can be supported by the PCM interface at any one time.

WT11 can operate as the PCM interface Master generating an output clock of 128, 256 or 512kHz. When configured as PCM interface slave it can operate with an input clock up to 2048kHz. WT11 is compatible with a variety of clock formats, including Long Frame Sync, Short Frame Sync and GCI timing environments.

It supports 13 or 16-bit linear, 8-bit μ -law or A-law companded sample formats at 8ksamples/s and can receive and transmit on any selection of three of the first four slots following PCM_SYNC. The PCM configuration options are enabled by setting the PS Key PS KEY_PCM_CONFIG32 (0x1b3). WT11 interfaces directly to PCM audio devices including the following:

- Qualcomm MSM 3000 series and MSM 5000 series CDMA baseband devices
- OKI MSM7705 four channel A-law and μ -law CODEC
- Motorola MC145481 8-bit A-law and μ -law CODEC
- Motorola MC145483 13-bit linear CODEC
- STW 5093 and 5094 14-bit linear CODECs
- BlueCore4-External is also compatible with the Motorola SSI™ interface
-

4.4.1 PCM Interface Master/ Slave

When configured as the Master of the PCM interface, WT11 generates PCM_CLK and PCM_SYNC.

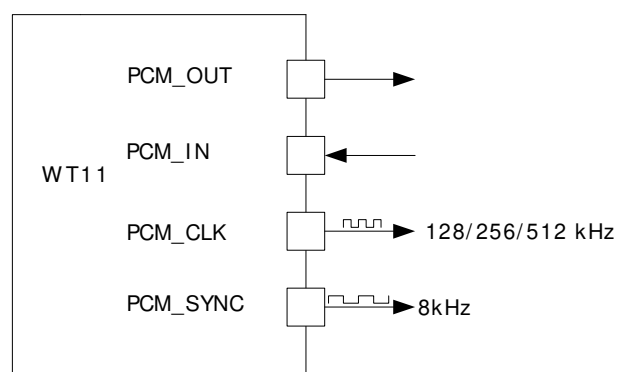

Figure 14: WT11 as PCM master

When configured as the Slave of the PCM interface, WT11 accepts PCM_CLK and PCM_SYNC. PCM_CLK rates up to 2048kHz are accepted.

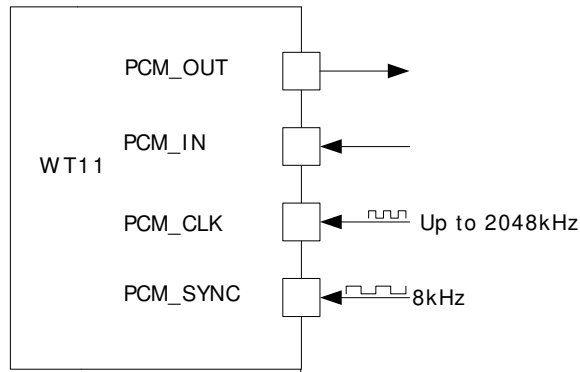

Figure 15: WT11 as PCM slave

4.4.2 Long Frame Sync

Long Frame Sync is the name given to a clocking format that controls the transfer of PCM data words or samples. In Long Frame Sync, the rising edge of PCM_SYNC indicates the start of the PCM word. When WT11 is configured as PCM Master, generating PCM_SYNC and PCM_CLK, then PCM_SYNC is 8-bits long. When BlueCore4-External is configured as PCM Slave, PCM_SYNC may be from two consecutive falling edges of PCM_CLK to half the PCM_SYNC rate, i.e. 62.5µs long.

WT11 samples PCM_IN on the falling edge of PCM_CLK and transmits PCM_OUT on the rising edge. PCM_OUT may be configured to be high impedance on the falling edge of PCM_CLK in the LSB position or on the rising edge.

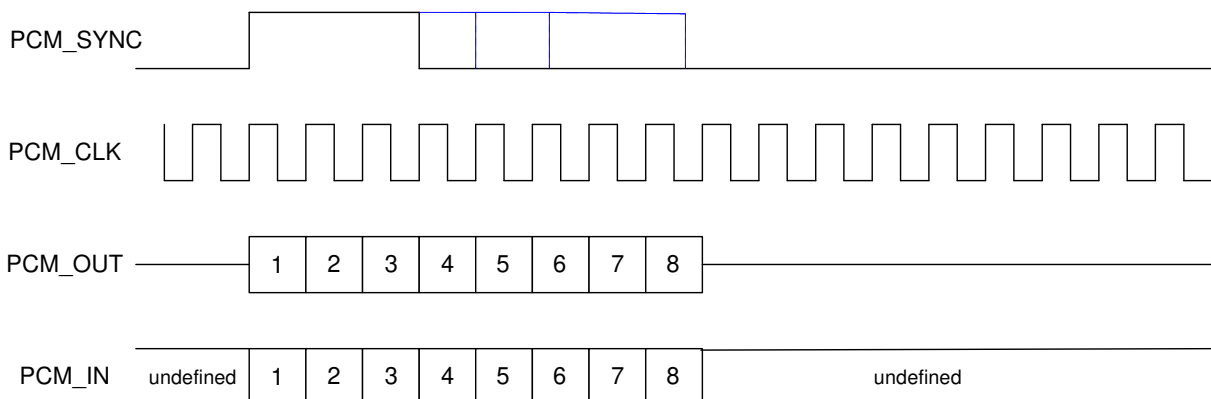

Figure 16: Long frame sync (shown with 8-bit Companded Sample)

4.4.3 Short Frame Sync

In Short Frame Sync the falling edge of PCM_SYNC indicates the start of the PCM word. PCM_SYNC is always one clock cycle long.

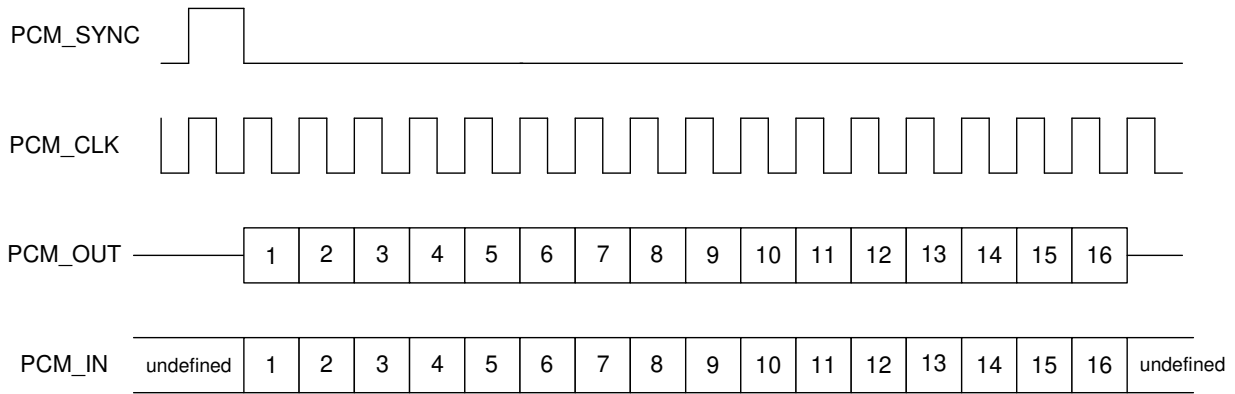

Figure 17: Short frame sync (shown with 16-bit Companded Sample)

As with Long Frame Sync, WT11 samples PCM_IN on the falling edge of PCM_CLK and transmits PCM_OUT on the rising edge. PCM_OUT may be configured to be high impedance on the falling edge of PCM_CLK in the LSB position or on the rising edge.

4.4.4 Multi Slot Operation

More than one SCO connection over the PCM interface is supported using multiple slots. Up to three SCO connections can be carried over any of the first four slots.

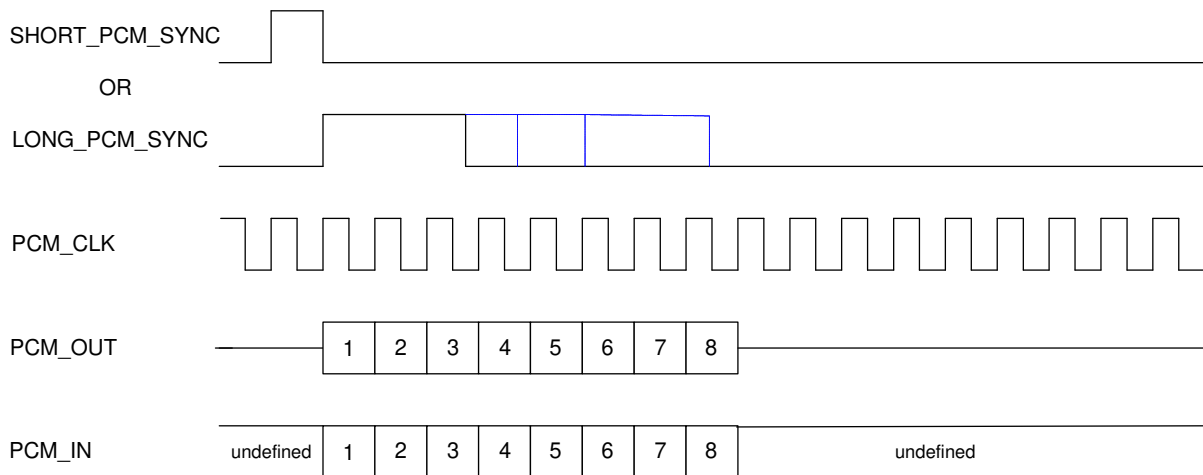

Figure 18: Multi Slot Operation with Two Slots and 8-bit Companded Samples

4.4.5 GCI Interface

WT11 is compatible with the General Circuit Interface, a standard synchronous 2B+D ISDN timing interface. The two 64Kbps B channels can be accessed when this mode is configured.

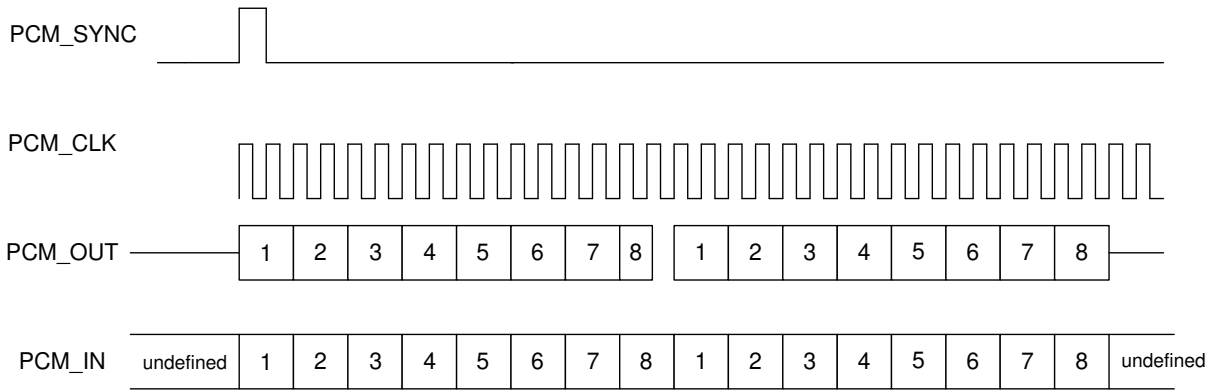

Figure 19: GCI Interface

The start of frame is indicated by the rising edge of PCM_SYNC and runs at 8kHz. With WT11 in Slave mode, the frequency of PCM_CLK can be up to 4.096MHz.

4.4.6 Slots and Sample Formats

WT11 can receive and transmit on any selection of the first four slots following each sync pulse. Slot durations can be either 8 or 16 clock cycles. Durations of 8 clock cycles may only be used with 8-bit sample formats. Durations of 16 clocks may be used with 8, 13 or 16-bit sample formats.

WT11 supports 13-bit linear, 16-bit linear and 8-bit μ -law or A-law sample formats. The sample rate is 8ksamples/s. The bit order may be little or big Endian. When 16-bit slots are used, the 3 or 8 unused bits in each slot may be filled with sign extension, padded with zeros or a programmable 3-bit audio attenuation compatible with some Motorola CODECs.

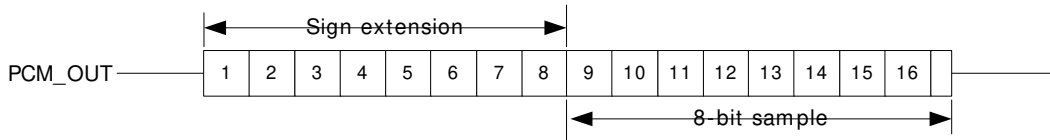

Figure 20: 16-bit slot with 8-bit companded sample and sign extension selected

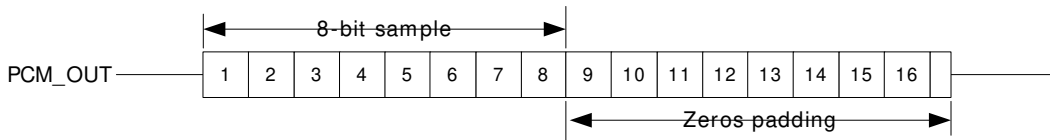

Figure 21: 16-bit slot with 8-bit companded sample and zeros padding selected

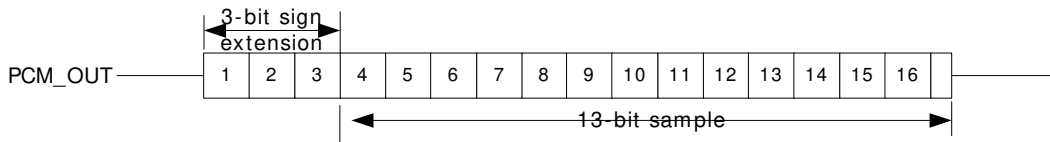

Figure 22: 16-bit slot with 13-bit linear sample and sign extension selected

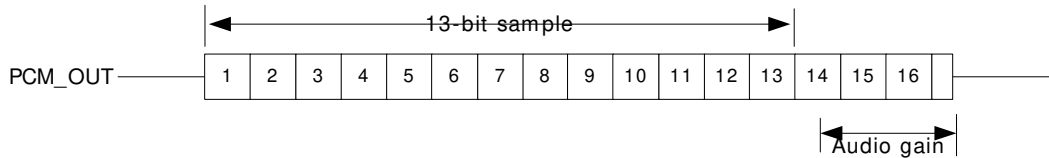

Figure 23: 16-bit slot with 13-bit linear sample and audio gain selected

4.4.7 Additional Features

WT11 has a mute facility that forces PCM_OUT to be 0. In Master mode, PCM_SYNC may also be forced to 0 while keeping PCM_CLK running which some CODECS use to control power down.

4.4.8 PCM Configuration

The PCM configuration is set using two PS Keys, PSKEY_PCM_CONFIG32 and PSKEY_PCM_LOW_JITTER_CONFIG. The following tables detail these PS Keys. The default for PSKEY_PCM_CONFIG32 key is 0x00800000 i.e. first slot following sync is active, 13-bit linear voice format, long frame sync and interface master generating 256kHz PCM_CLK from 4MHz internal clock with no tri-stating of PCM_OUT. PSKEY_PCM_LOW_JITTER_CONFIG is described in Table 10.

Name	Bit position	Description
-	0	Set to 0
SLAVE MODE EN	1	0 selects Master mode with internal generation of PCM_CLK and PCM_SYNC. 1 selects Slave mode requiring externally generated PCM_CLK and PCM_SYNC. This should be set to 1 if 48M_PCM_CLK_GEN_EN (bit 11) is set.
SHORT SYNC EN	2	0 selects long frame sync (rising edge indicates start of frame), 1 selects short frame sync (falling edge indicates start of frame).
-	3	Set to 0
SIGN EXTENDED EN	4	0 selects padding of 8 or 13-bit voice sample into a 16-bit slot by inserting extra LSBs, 1 selects sign extension. When padding is selected with 3-bit voice sample, the 3 padding bits are the audio gain setting; with 8-bit samples the 8 padding bits are zeroes.
LSB FIRST EN	5	0 transmits and receives voice samples MSB first, 1 uses LSB first.
TX TRISTATE EN	6	0 drives PCM_OUT continuously, 1 tri-states PCM_OUT immediately after the falling edge of PCM_CLK in the last bit of an active slot, assuming the next slot is not active.
TX TRISTATE RISING EDGE EN	7	0 tristates PCM_OUT immediately after the falling edge of PCM_CLK in the last bit of an active slot, assuming the next slot is also not active. 1 tristates PCM_OUT after the rising edge of PCM_CLK.
SYNC SUPPRESS EN	8	0 enables PCM_SYNC output when master, 1 suppresses PCM_SYNC whilst keeping PCM_CLK running. Some CODECS utilize this to enter a low power state.
GCI MODE EN	9	1 enables GCI mode.
MUTE EN	10	1 forces PCM_OUT to 0.
48M PCM CLK GEN EN	11	0 sets PCM_CLK and PCM_SYNC generation via DDS from internal 4 MHz clock, as for BlueCore4-External. 1 sets PCM_CLK and PCM_SYNC generation via DDS from internal 48 MHz clock.
LONG LENGTH SYNC EN	12	0 sets PCM_SYNC length to 8 PCM_CLK cycles and 1 sets length to 16 PCM_CLK cycles. Only applies for long frame sync and with 48M_PCM_CLK_GEN_EN set to 1.
-	[20:16]	Set to 0b00000.
MASTER CLK RATE	[22:21]	Selects 128 (0b01), 256 (0b00), 512 (0b10) kHz PCM_CLK frequency when master and 48M_PCM_CLK_GEN_EN (bit 11) is low.
ACTIVE SLOT	[26:23]	Default is 0001. Ignored by firmware
SAMPLE_FORMAT	[28:27]	Selects between 13 (0b00), 16 (0b01), 8 (0b10) bit sample with 16 cycle slot duration 8 (0b11) bit sample 8 cycle slot duration.

Table 9: PSKEY_PCM_CONFIG32 description

Name	Bit position	Description
CNT LIMIT	[12:0]	Sets PCM_CLK counter limit
CNT RATE	[23:16]	Sets PCM_CLK count rate.
SYNC LIMIT	[31:24]	Sets PCM_SYNC division relative to PCM_CLK.

Table 10: PSKEY_PCM_LOW_JITTER_CONFIG Description

5. I/O PARALLEL PORTS

The Parallel Input Output (PIO) Port is a general-purpose I/O interface to WT11. The port consists of six programmable, bi-directional I/O lines, PIO[2:7]. Programmable I/O lines can be accessed either via an embedded application running on WT11 or via private channel or manufacturer-specific HCI commands.

All PIO lines are configured as inputs with weak pull downs at reset.

PIO[2] / USB_PULL_UP (1)

The function depends on whether WT11 is a USB or UART capable version. On UART versions, this terminal is a programmable I/O. On USB versions, it can drive a pull-up resistor on USB_D+. For application using external RAM this terminal may be programmed for chip select.

PIO[3] / USB_WAKE_UP (1)

On UART versions of WT11 this terminal is a programmable I/O. On USB versions, its function is selected by setting the Persistent Store Key PSKEY_USB_PIO_WAKEUP (0x2cf) either as a programmable I/O or as a USB_WAKE_UP function.

PIO[4] / USB_ON (1)

On UART versions of WT11 this terminal is a programmable I/O. On USB versions, the USB_ON function is also selectable.

PIO[5] / USB_DETACH (1)

On UART versions of WT11 this terminal is a programmable I/O. On USB versions, the USB_DETACH function is also selectable.

PIO[6] / CLK_REQ

Function is determined by Persistent Store Keys. Using PSKEY_CLOCK_REQUEST_ENABLE, (0x246) this terminal can be configured to be low when WT11 is in deep sleep and high when a clock is required. The clock must be supplied within 4ms of the rising edge of PIO[6] to avoid losing timing accuracy in certain Bluetooth operating modes.

PIO[7]

Programmable I/O terminal.

6. SOFTWARE STACKS

WT11 is supplied with Bluetooth v2.0 + EDR compliant stack firmware, which runs on the internal RISC microcontroller.

The WT11 software architecture allows Bluetooth processing and the application program to be shared in different ways between the internal RISC microcontroller and an external host processor (if any). The upper layers of the Bluetooth stack (above HCI) can be run either on-chip or on the host processor.

6.1 iWRAP Stack

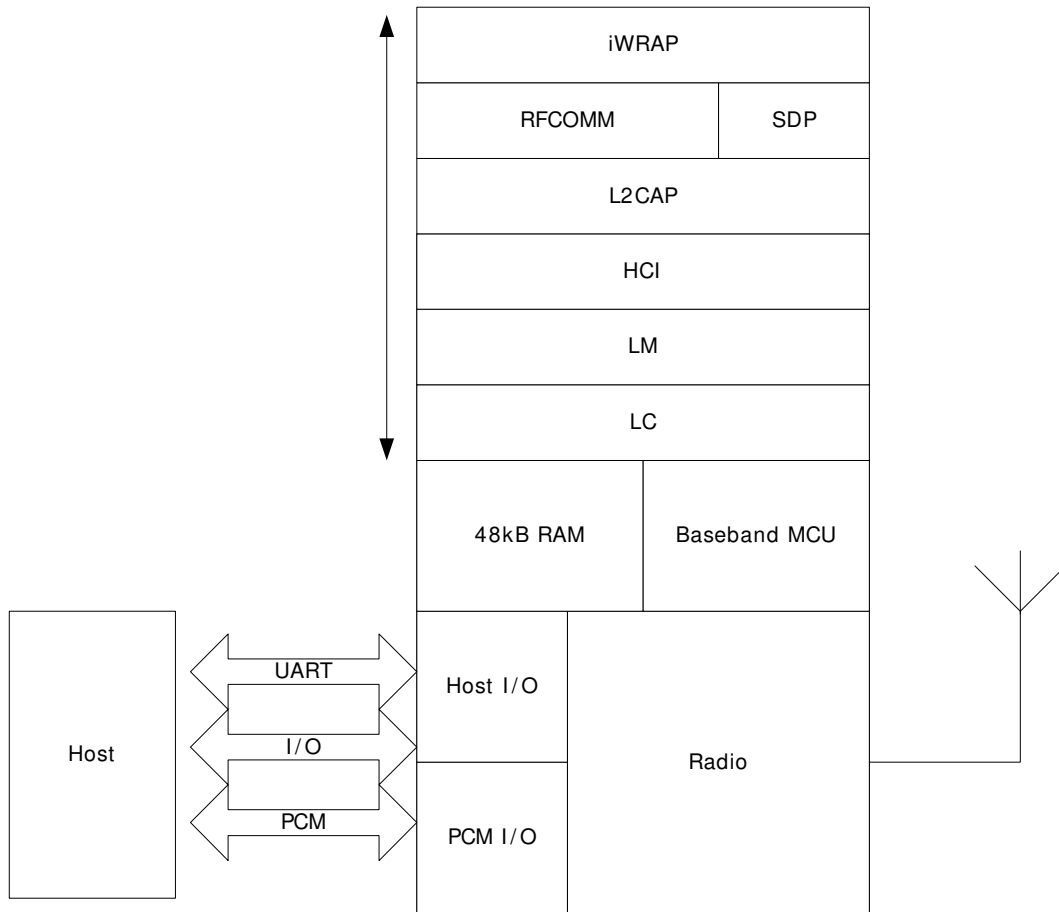

Figure 24: WRAP THOR VM Stack

In figure 24 above, the iWRAP software solution is described. In this version of the stack firmware shown no host processor is required to run the Bluetooth protocol stack. All software layers, including application software, run on the internal RISC processor in a protected user software execution environment known as a Virtual Machine (VM).

The host processor interfaces to iWRAP software via one or more of the physical interfaces, which are also shown in the figure 24. The most common interfacing is done via UART interface using the ASCII commands supported by the iWRAP software. With these ASCII commands the user can access Bluetooth functionality without paying any attention to the complexity, which lies in the Bluetooth protocol stack.

The user may write applications code to run on the host processor to control iWRAP software with ASCII commands and to develop Bluetooth powered applications.

Notes:

More details of iWRAP software and its features can be found from *iWRAP User Guide* which can be downloaded from www.bluegiga.com.

6.2 HCI Stack

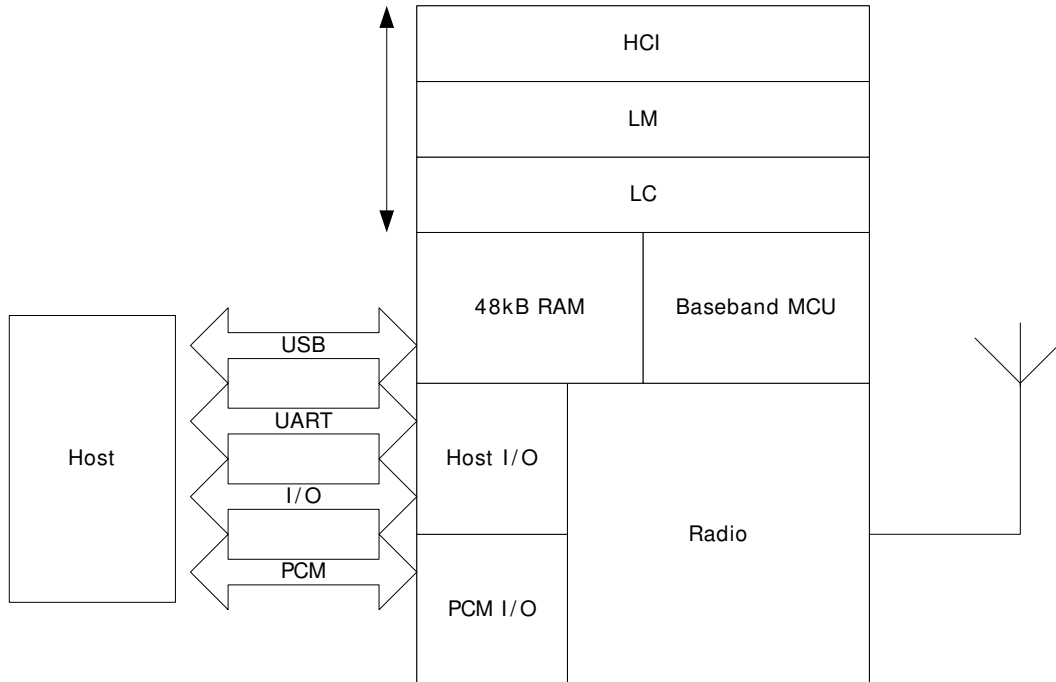

Figure 25: WRAP THOR HCI Stack

In the implementation shown in figure 25 the internal processor runs the Bluetooth stack up to the Host Controller Interface (HCI). The Host processor must provide all upper layers including the application.

Features of HCI Stack

1. New Bluetooth v2.0 + EDR Mandatory Functionality:

- (AFH), including classifier
- Faster connection – enhanced inquiry scan (immediate FHS response)
- LMP improvements
- Parameter ranges

2. Optional v2.0 functionality supported:

- Adaptive Frequency Hopping (AFH) as Master and Automatic Channel Classification
- Fast Connect – Interlaced Inquiry and Page Scan plus RSSI during Inquiry
- Extended SCO (eSCO), eV3 + CRC, eV4, eV5
- SCO handle
- Synchronization

The firmware has been written against the Bluetooth v2.0 + EDR Specification.

- Bluetooth components:
 - Baseband (including LC)
 - LM
 - HCI

- Standard USB v2.0 (full speed) and UART HCI Transport Layers
- All standard radio packet types
- Full Bluetooth data rate, enhanced data rates of 2 and 3Mbps(1)
- Operation with up to seven active slaves(1)
- Scatternet v2.5 operation
- Maximum number of simultaneous active ACL connections: 7(2)
- Maximum number of simultaneous active SCO connections: 3(2)
- Operation with up to three SCO links, routed to one or more slaves
- All standard SCO voice coding, plus “transparent SCO”
- Standard operating modes: page, inquiry, page-scan and inquiry-scan
- All standard pairing, authentication, link key and encryption operations
- Standard Bluetooth power saving mechanisms: Hold, Sniff and Park modes, including Forced Hold”
- Dynamic control of peers’ transmit power via LMP
- Master/Slave switch
- Broadcast
- Channel quality driven data rate
- All standard Bluetooth Test Modes

The firmware’s supported Bluetooth features are detailed in the standard Protocol Implementation Conformance (PICS) documents. They can be asked separately form support@bluegiga.com.

Extra functionality:

- Supports BlueCore Serial Protocol (BCSP) – a proprietary, reliable alternative to the standard Bluetooth UART Host Transport
- Provides a set of approximately 50 manufacturer-specific HCI extension commands. This command set (called BCCMD – “BlueCore Command”), provides:
 - Access to the chip’s general-purpose PIO port
 - The negotiated effective encryption key length on established Bluetooth links
 - Access to the firmware’s random number generator
 - Controls to set the default and maximum transmit powers – these can help minimize interference between overlapping, fixed-location piconets
- Dynamic UART configuration

- Radio transmitter enable/disable – a simple command connects to a dedicated hardware switch that determines whether the radio can transmit
- The firmware can read the voltage on a pair of the chip’s external pins. This is normally used to build a battery monitor, using either VM or host code
- A block of BCCMD commands provides access to the chip’s “persistent store” configuration database (PS). The database sets the device’s Bluetooth address, Class of Device, radio (transmit class) configuration, SCO routing, LM, USB and DFU constants, etc.
- A UART “break” condition can be used in three ways:
 - Presenting a UART break condition to the chip can force the chip to perform a hardware reboot
 - Presenting a break condition at boot time can hold the chip in a low power state, preventing normal initialization while the condition exists
 - With BCSP, the firmware can be configured to send a break to the host before sending data – normally used to wake the host from a deep sleep state
- The DFU standard has been extended with public/private key authentication, allowing manufacturers to control the firmware that can be loaded onto their Bluetooth modules
- A modified version of the DFU protocol allows firmware upgrade via the chip’s UART
- A block of “radio test” or BIST commands allows direct control of the chip’s radio. This aids the development of modules’ radio designs, and can be used to support Bluetooth qualification.
- Virtual Machine (VM). The firmware provides the VM environment in which to run application-specific code. Although the VM is mainly used with BlueLab and “RFCOMM builds” (alternative firmware builds providing L2CAP, SDP and RFCOMM), the VM can be used with this build to perform simple tasks such as flashing LED’s via the chip’s PIO port.
- Hardware low power modes: shallow sleep and deep sleep. The chip drops into modes that significantly reduce power consumption when the software goes idle.
- SCO channels are normally routed via HCI (over BCSP). However, up to three SCO channels can be routed over the chip’s single PCM port (at the same time as routing any remaining SCO channels over HCI).
- Co-operative existence with 802.11b/g chipsets. The device can be optionally configured to support a number of different co-existence schemes including:
 - TDMA - Bluetooth and WLAN avoid transmitting at the same time.
 - FDMA - Bluetooth avoids transmitting within the WLAN channel
 - Combination TDMA & FDMA - Bluetooth avoids transmitting in the WLAN channel only when WLAN is active.
- Please refer to separate documentation for full details of the co-existence schemes that CSR supports.

Notes:

1. Supports basic data rate up to 723.2kbps asymmetric, maximum allowed by Bluetooth v2.0 + EDR specification
2. WT11 supports all combinations of active ACL and SCO channels for both Master and
3. Always refer to the Firmware Release Note for the specific functionality of a particular build.

6.3 RFCOMM Stack

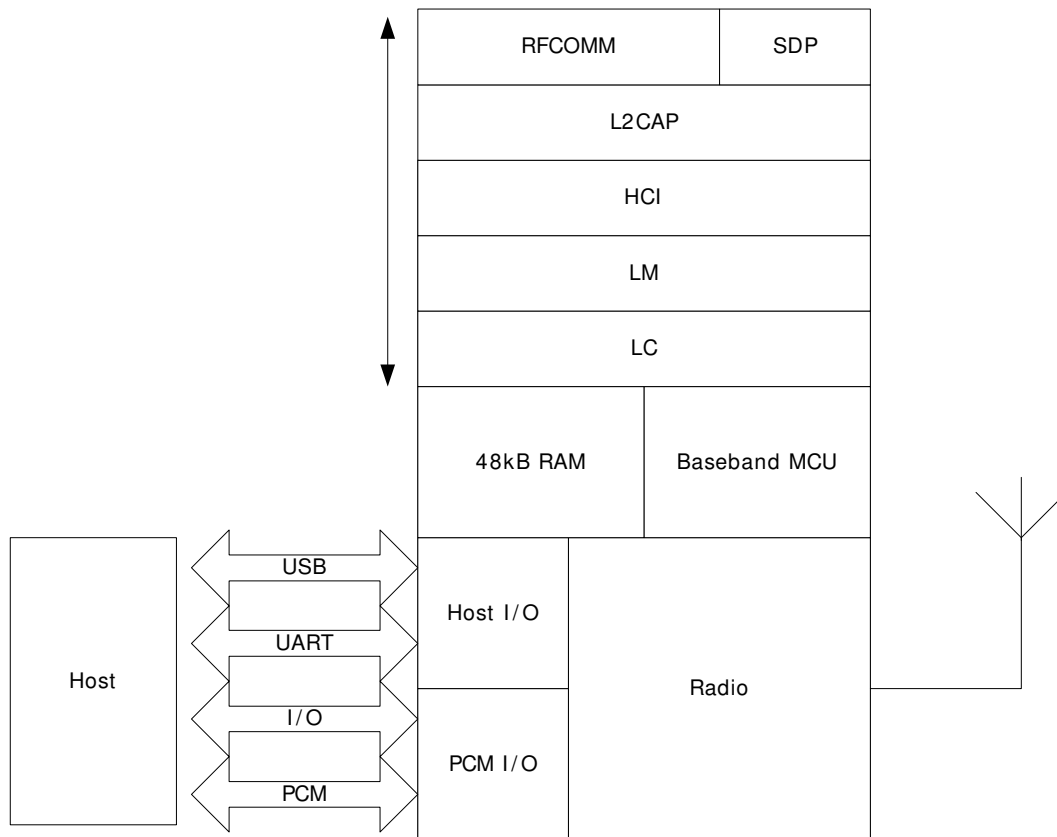

Figure 26: WRAP THOR RFCOMM stack

In the version of the firmware, shown in Figure 26, the upper layers of the Bluetooth stack up to RFCOMM are run on-chip. This reduces host-side software and hardware requirements at the expense of some of the power and flexibility of the HCI only stack.

Features of RFCOMM Stack

Interfaces to Host:

- RFCOMM, an RS-232 serial cable emulation protocol
- SDP, a service database look-up protocol

Connectivity:

- Maximum number of active slaves: 3
- Maximum number of simultaneous active ACL connections: 3
- Maximum number of simultaneous active SCO connections: 3
- Data Rate: up to 350kbps¹

Security:

- Full support for all Bluetooth security features up to and including strong (128-bit) encryption.

Power Saving:

- Full support for all Bluetooth power saving modes (Park, Sniff and Hold).

Data Integrity:

- CQDDR increases the effective data rate in noisy environments.
- RSSI used to minimize interference to other radio devices using the ISM band.

Notes:

1. The data rate is with respect to WT11 with basic data rate packets.

6.4 VM Stack

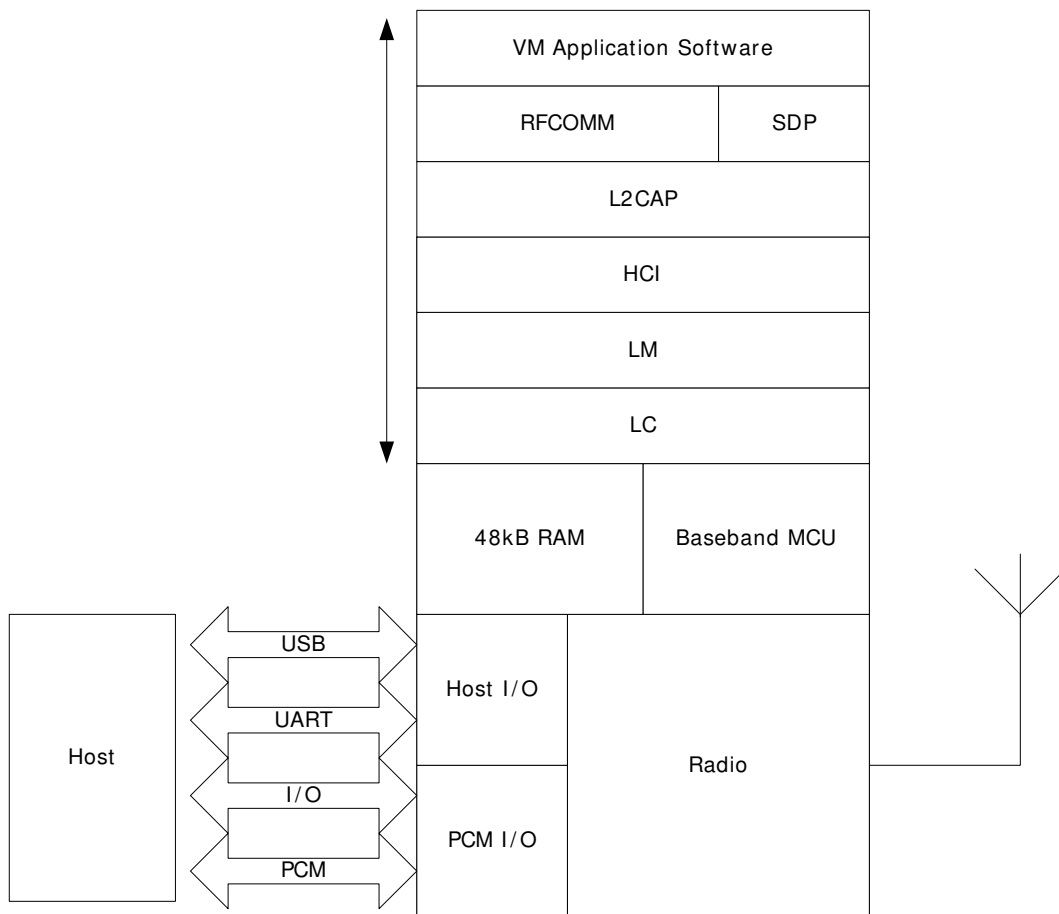

Figure 27: WRAP THOR VM Stack

In figure 27, this version of the stack firmware shown requires no host processor (but can use a host processor for debugging etc.). All software layers, including application software, run on the internal RISC processor in a protected user software execution environment known as a Virtual Machine (VM).

The user may write custom application code to run on the BlueCore VM using BlueLab™ software development kit (SDK) supplied with the Casira development kit, available separately from Bluegiga or directly from CSR. This code will then execute alongside the main WRAP THOR firmware. The user is able to make calls to the WRAP THOR firmware for various operations. WRAP THOR firmware is not equal to iWRAP firmware, which on the contrary does not allow user to run own firmware in the module.

The execution environment is structured so the user application does not adversely affect the main software routines, thus ensuring that the Bluetooth stack software component does not need re-qualification when the application is changed.

Using the VM and the BlueLab SDK the user is able to develop applications such as a cordless headset or other profiles without the requirement of a host controller. BlueLab is supplied with example code including a full implementation of the headset profile.

Notes:

Sample applications to control PIO lines can also be written with BlueLab SDK and the VM for the HCI stack.

6.5 HID Stack

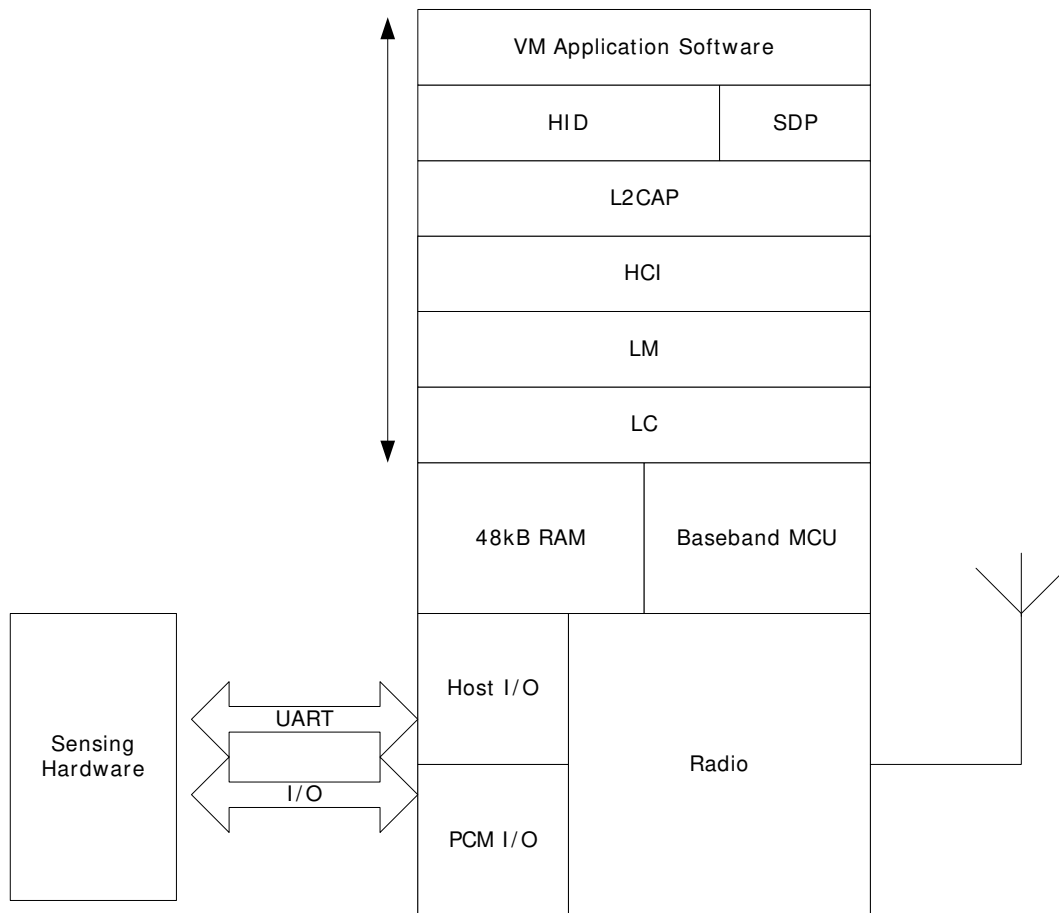

Figure 28: WRAP THOR HID stack

This version of the stack firmware requires no host processor. All software layers, including application software, run on the internal RISC microcontroller in a protected user software execution environment known as a virtual machine (VM).

The user may write custom application code to run on the BlueCore VM using BlueLab Professional software development kit (SDK) supplied with the BlueLab Professional and Casira development kits, available separately from CSR. This code will then execute alongside the main BlueCore firmware. The user is able to make calls to the BlueCore firmware for various operations.

The execution environment is structured so the user application does not adversely affect the main software routines, thus ensuring that the Bluetooth stack software component does not need re-qualification when the application is changed.

Using the VM and the BlueLab Professional SDK the user is able to develop Bluetooth HID devices such as an optical mouse or keyboard. The user is able to customize features such as power management and connect/reconnect behavior.

The HID I/O component in the HID stack controls low latency data acquisition from external sensor hardware. With this component running in native code, it does not incur the overhead of the VM code interpreter. Supported external sensors include 5 mouse buttons, the Agilent ADNS-2030 optical sensor, quadrature scroll wheel, direct coupling to a keyboard matrix and a UART interface to custom hardware.

A reference schematic for implementing a three button, optical mouse with scroll wheel is available separately.

Software Development

WT11 Evaluation Kits are available to allow the evaluation of the WT11 hardware and software as well CSR BlueLab toolkit for developing on-chip and host software.

7. ENHANCED DATA RATE

EDR has been introduced to provide 2x and optionally 3x data rates with minimal disruption to higher layers of the Bluetooth stack. CSR supports both of the new data rates, with WT11. WT11 is compliant with revision v2.0.E.2 of the specification.

7.1 Enhanced Data Rate Baseband

At the baseband level EDR uses the same 1.6kHz slot rate as basic data rate and therefore the packets can be 1, 3, or 5 slots long as per the basic data rate. Where EDR differs from the basic data rate is that in the same 1MHz symbol rate 2 or 3bits are used per symbol, compared to 1bit per symbol used by the basic data rate. To achieve the increase in number of bits symbol, two new modulation schemes have been introduced as summarized in Table 11 presented below and the modulation schemes are explained in the further sections.

Scheme	Bits per symbol	Modulation
Basic data rate	1	GFSK
Enhanced data rate	2	P/4 DQPSK
Enhanced data rate	3	8DPSK (optional)

Table 11: Data rate schemes

Although the EDR uses new packets Link establishment and management are unchanged and still use Basic Rate packets.

7.2 Enhanced Data Rate $\Pi/4$ DQPSK

4-state Differential Phase Shift Keying

2 bits determine phase shift between consecutive symbols

2 bits determine phase shift between consecutive symbols

S/4 rotation avoids phase shift of S, which would cause large amplitude variation

Raised Cosine pulse shaping filter to further reduce side band emissions

Bit pattern	Phase shift
00	$\Pi/4$
01	$3 \Pi/4$
10	$-3 \Pi/4$
11	$-\Pi/4$

Table 12: 2 bits determine phase shift between consecutive symbols

7.3 8DQPSK

8-state Differential Phase-Shift Keying

Three bits determine phase shift between consecutive symbols.

Bit pattern	Phase shift
000	0
001	$\Pi/4$
011	$\Pi/2$
010	$3 \Pi/4$
110	Π
111	$-3 \Pi/4$
101	$-\Pi/2$
100	$-\Pi/4$

Table 13: 3 bits determine phase shift between consecutive symbols

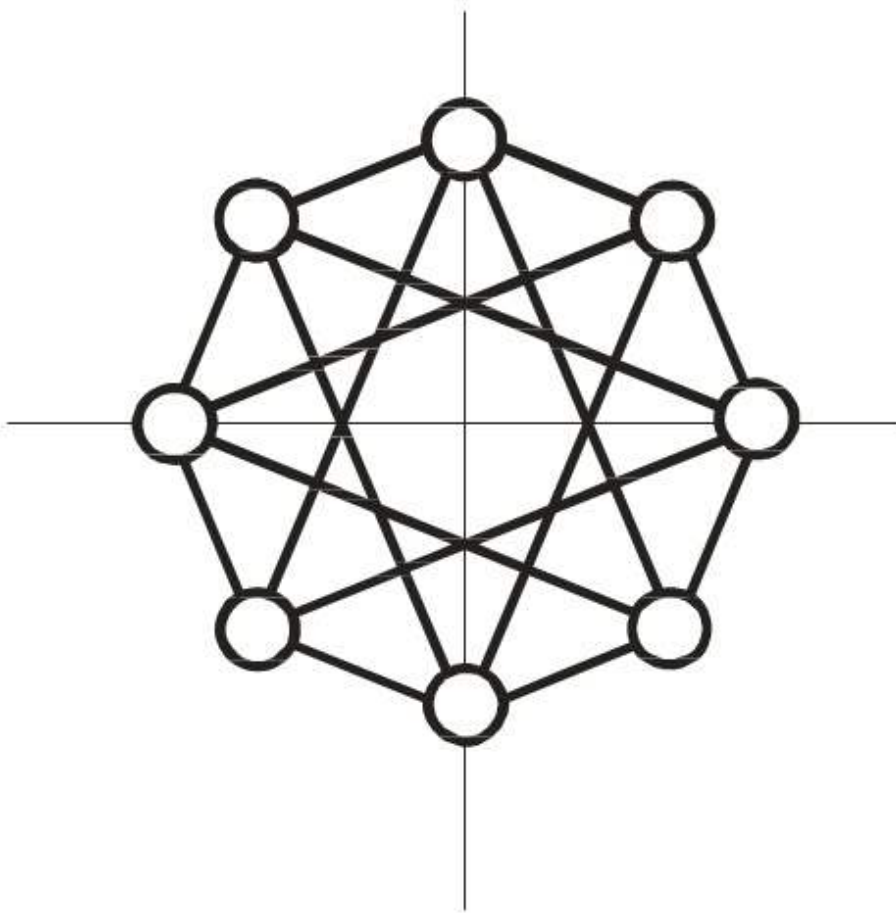

Figure 29: 8DQPSK

8. LAYOUT AND SOLDERING CONSIDERATIONS

8.1 Soldering recommendations

WT11 is compatible with industrial standard reflow profile for Pb-free solders. The reflow profile used is dependent on the thermal mass of the entire populated PCB, heat transfer efficiency of the oven and particular type of solder paste used. Consult the datasheet of particular solder paste for profile configurations.

Bluegiga Technologies will give following recommendations for soldering the module to ensure reliable solder joint and operation of the module after soldering. Since the profile used is process and layout dependent, the optimum profile should be studied case by case. Thus following recommendation should be taken as a starting point guide.

- Refer to technical documentations of particular solder paste for profile configurations
- Avoid using more than one flow.
- Reliability of the solder joint and self-alignment of the component are dependent on the solder volume. Minimum of 150µm stencil thickness is recommended.
- Aperture size of the stencil should be 1:1 with the pad size.
- A low residue, “no clean” solder paste should be used due to low mounted height of the component.

8.2 Layout guidelines

It is strongly recommended to use good layout practices to ensure proper operation of the module. Placing copper or any metal near antenna deteriorates its operation by having effect on the matching properties and the radiation efficiency. Metal shield around the antenna will prevent the radiation and thus metal case should not be used with the module.

When using overlapping GND planes, use grounding vias separated max 3 mm apart at the edge of grounding areas to prevent RF penetrating inside the PCB and causing an unintentional resonator. Use GND vias all around the PCB edges. Figure 30 illustrates recommended PCB design around the antenna of WT11 when the module is placed at the edge of a PCB.

Avoid placing bare copper, such as vias, under the module to avoid shorts caused by the vias at the bottom layer of the module. Avoid placing any metal closer than 20 mm from the antenna.

Avoid placing plastic or any other dielectric material closer than 5 mm to the antenna. The impedance matching of the antenna is optimized with the evaluation kit and any dielectric material, such as a plastic case, closer than 5 mm to the antenna will move the resonant frequency down wards. Any dielectric material closer than 2 mm to the antenna will have a radical effect on the range of the module. It is highly recommended to strictly follow the layout show in the figure 30 using FR4 with thickness of 1 mm. In a case, when thicker FR4 or a plastic case close to the antenna is mandatory, the antenna matching can be retuned by removing extra FR4 under the antenna. Please contact Bluegiga technical support for details.

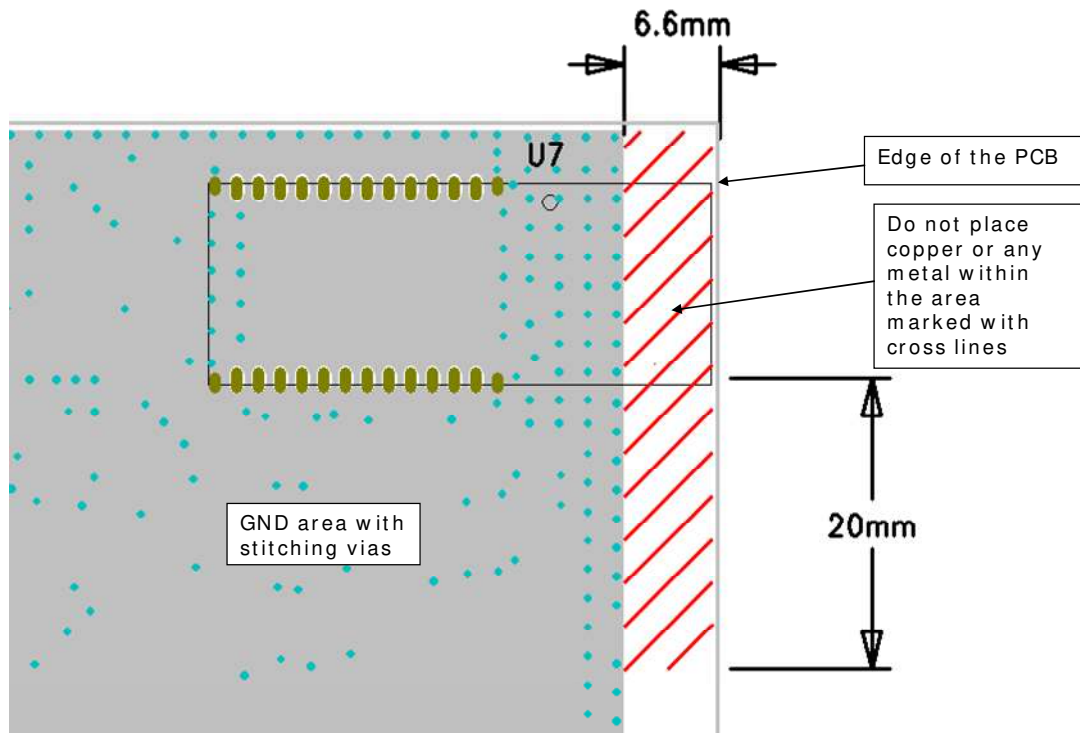

Figure 30: Recommended PCB layout around ACX antenna with the module at the edge of PCB

Following recommendations helps to avoid EMC problems arising in the design. Note that each design is unique and the following list do not consider all basic design rules such as avoiding capacitive coupling between signal lines. Following list is aimed to avoid EMC problems caused by RF part of the module. Use good consideration to avoid problems arising from digital signals in the design.

- Do not remove copper from the PCB more than needed. Use ground filling as much as possible. However remove small floating islands after copper pour.
- Do not place a ground plane underneath the antenna. The grounding areas under the module should be designed as shown in Figure 30.
- Use conductive vias separated max. 3 mm apart at the edge of the ground areas. This prevents RF to penetrate inside the PCB. Use ground vias extensively all over the PCB. If you allow RF freely inside the PCB, you have a potential resonator in your hand. All the traces in (and on) the PCB are potential antennas.
- Avoid loops.
- Ensure that signal lines have return paths as short as possible. For example if a signal goes to an inner layer through a via, always use ground vias around it. Locate them tightly and symmetrically around the signal vias.
- Routing of any sensitive signals should be done in the inner layers of the PCB.
- Sensitive traces should have a ground area above and under the line. If this is not possible make sure that the return path is short by other means (for example using a ground line next to the signal line).

9. WT11 PHYSICAL DIMENSIONS

WT11-A Dimensions

Tolerances ~ 10%

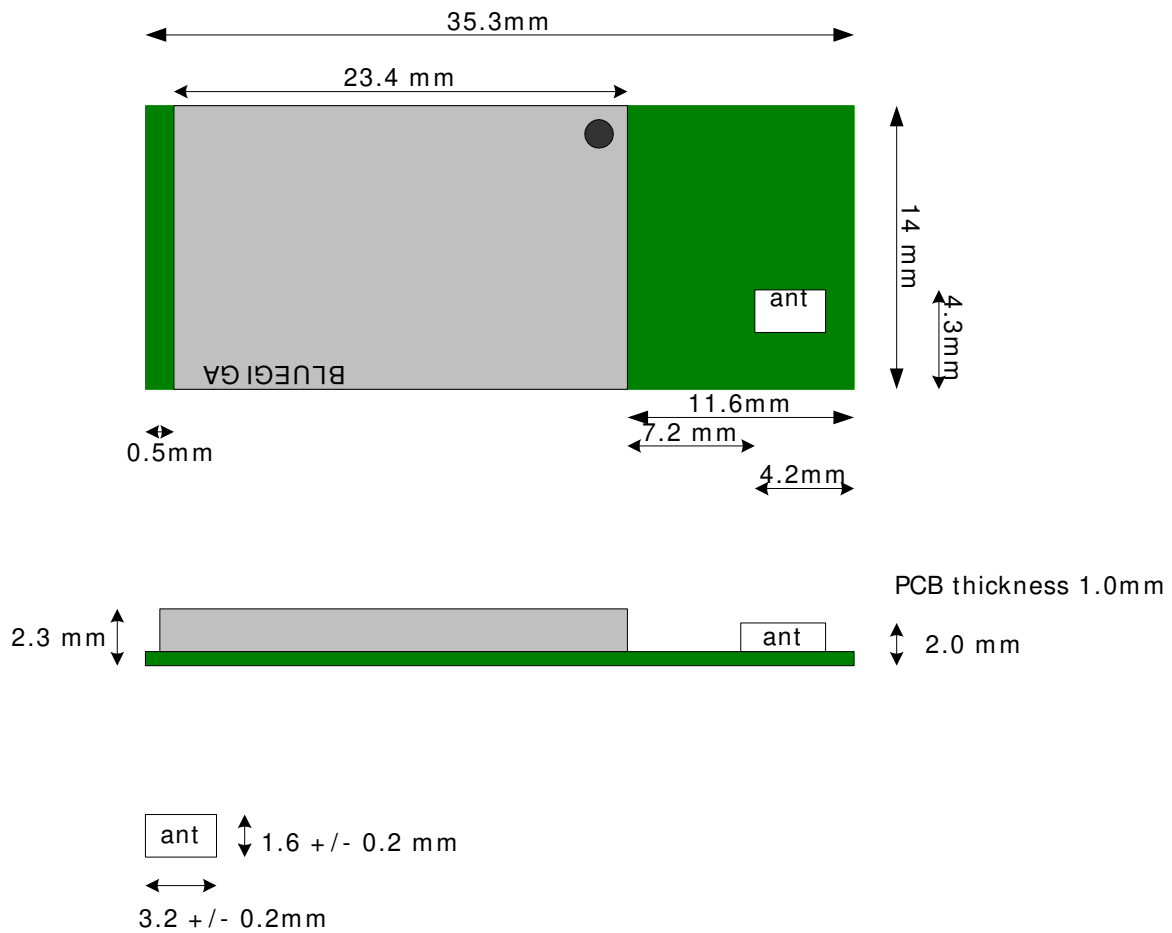

Figure 31: WT11-A dimensions

WT11-E Dimensions
Tolerances +/- 10%

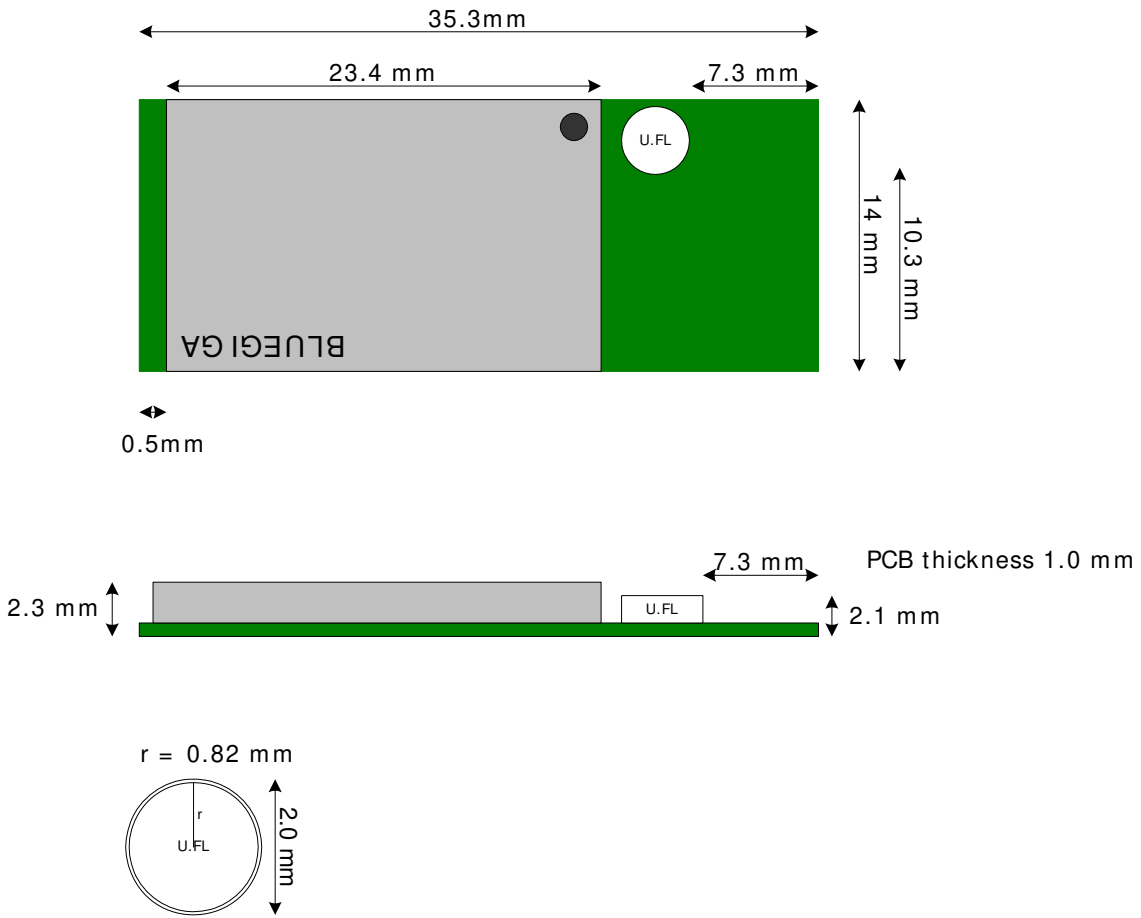

Figure 32: WT11-E dimensions

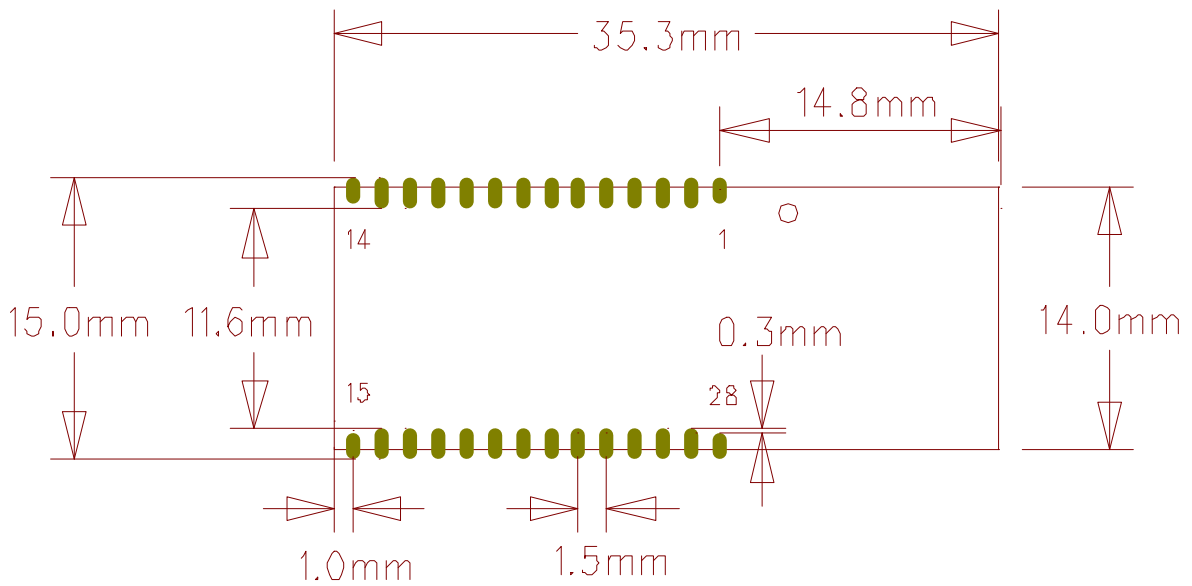

Figure 33: WT11 foot print and dimension (top view)

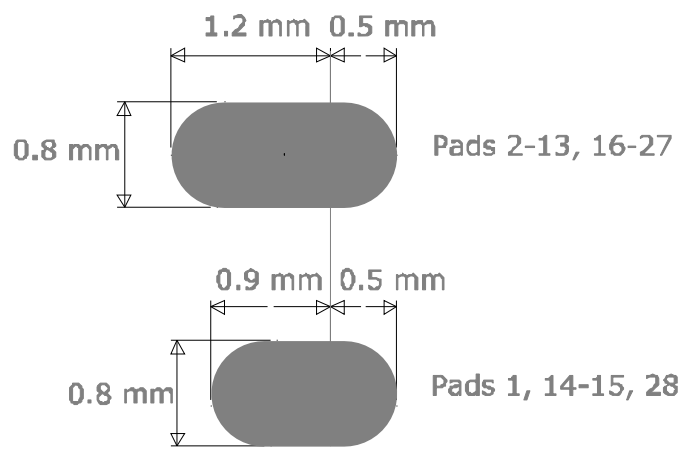

Figure 34: WT11 pad dimensions

10. PACKAGE

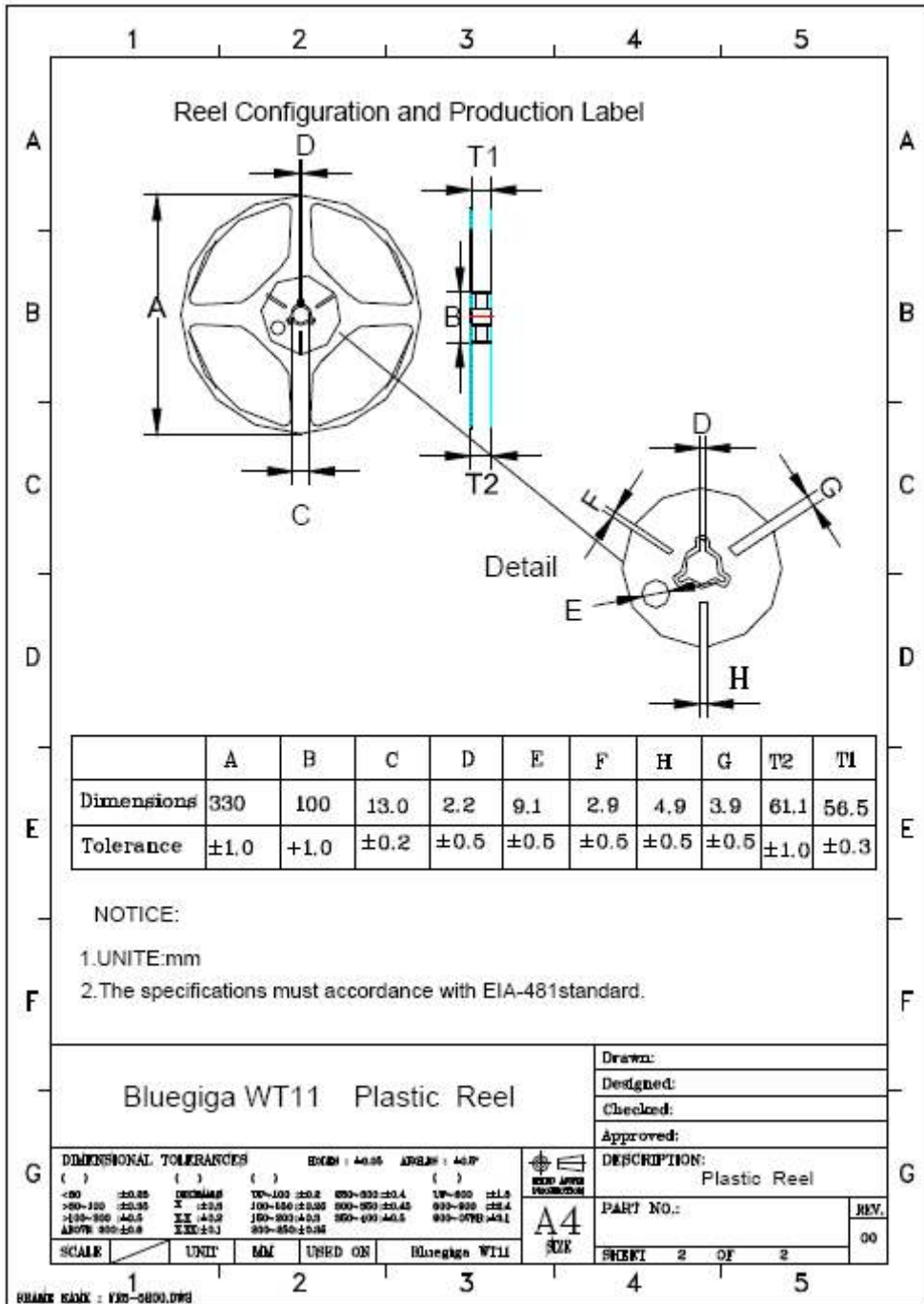

Figure 35: Reel information

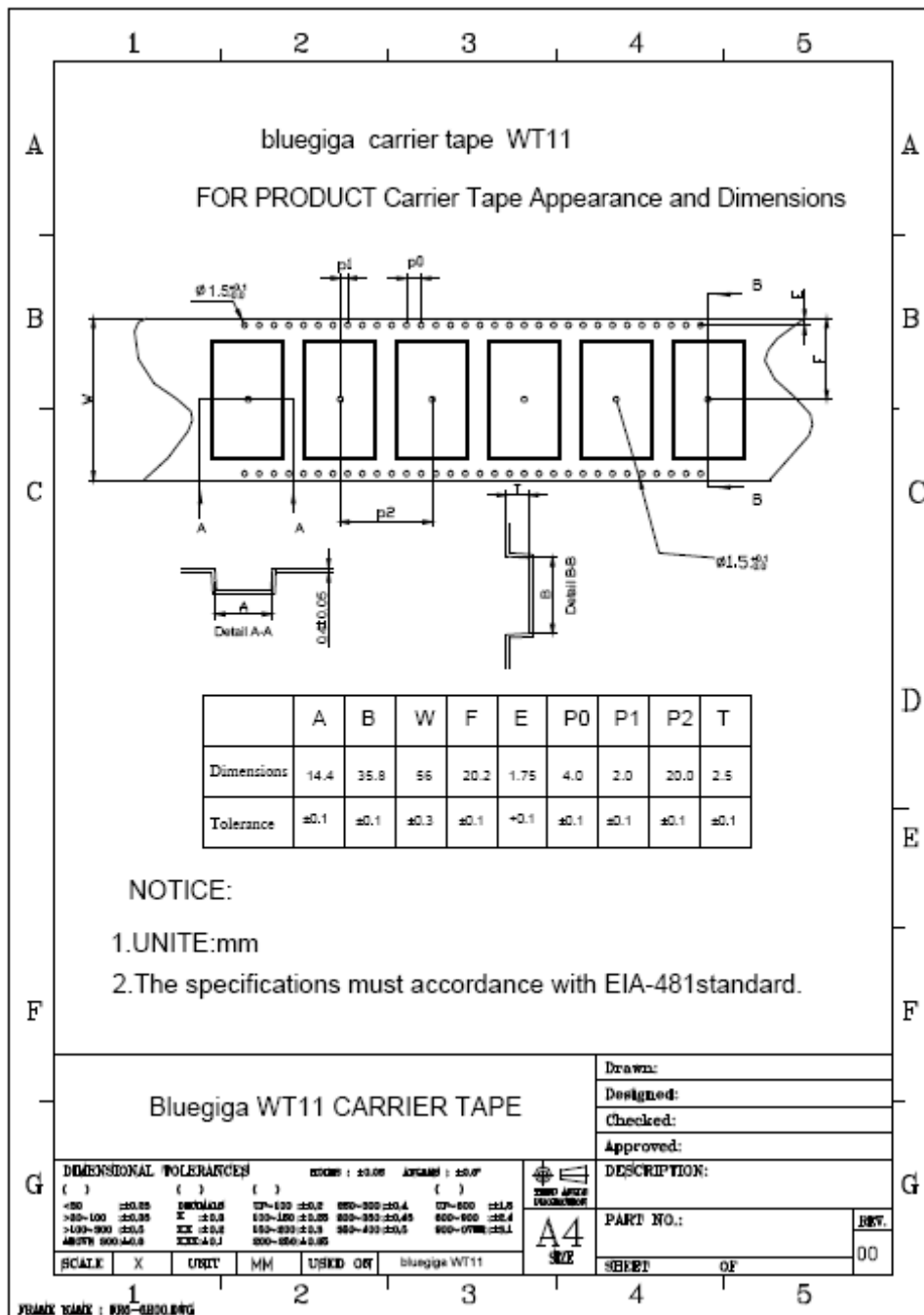

Figure 36: Tape information

11. CERTIFICATIONS

WT11 is compliant to the following specifications

11.1 Bluetooth

WT12 module is *Bluetooth* qualified and listed as an end product. If not modified in any way, it is a complete *Bluetooth* entity, containing software and hardware functionality as well as the whole RF-part including the antenna. This practically translates to that if the module is used without modification of any kind, it does not need any *Bluetooth* approval work. If changes are made in the parameter set, added profiles or in the antenna design, it is required to be submitted to a QQB (*Bluetooth* Qualification Body) for evaluation on what needs to be tested.

With HCI firmware WT11 will not meet the requirements of end product qualification.

WT11 is Bluetooth compliant to the following specifications

1. RF as defined in Part A of the Bluetooth specification v2.0+ EDR, Vol.2 Core System Package [Controller volume] (Class 1 operation) with all optional and mandatory features supported.
2. BB as defined in Part B of the Bluetooth specification v2.0+ EDR, Vol.2 Core System Package [Controller volume], and specified in the covered functionality of the Software Integrated Component (Bluetooth ID: B01294)
3. LM as defined in Part C of the Bluetooth specification v2.0+ EDR, Vol.2 Core System Package [Controller volume], and specified in the covered functionality of the Software Integrated Component (Bluetooth ID: B01294)
4. L2CAP as defined in Part A of the Bluetooth specification v2.0+ EDR, Vol.3 Core System Package [Controller volume], and specified in the covered functionality of the Software Integrated Component (Bluetooth ID: B00477)
5. SDP as defined in Part B of the Bluetooth specification v2.0+ EDR, Vol.3 Core System Package [Controller volume], and specified in the covered functionality of the Software Integrated Component (Bluetooth ID: B00477)
6. RFCOMM as defined in PART F:1 of the Bluetooth Core Specification v1.1 and specified in the covered functionality of the Software Integrated Component (Bluetooth ID: B00047).
7. Generic Access GAP as defined in PART C of the Bluetooth Core Specification v2.0+ EDR, Vol.3 Core Systems Package [Host Volume], and specified in the covered functionality of the Software Integrated Component (Bluetooth ID: B00047).
8. Serial Port Profile (SPP) as defined in PART K:5 of the Bluetooth Profile Specification v1.1, and specified in the covered functionality of the Software Integrated Component (Bluetooth ID: B00047).

Bluetooth identifier: B03005

11.2 FCC

Federal Communications Commission (FCC) Statement

15.21

You are cautioned that changes or modifications not expressly approved by the part responsible for compliance could void the user's authority to operate the equipment.

15.105(b)

This equipment has been tested and found to comply with the limits for a Class B digital device, pursuant to part 15 of the FCC rules. These limits are designed to provide reasonable protection against harmful interference in a residential installation. This equipment generates, uses and can radiate radio frequency energy and, if not installed and used in accordance with the instructions, may cause harmful interference to radio communications. However, there is no guarantee that interference will not occur in a particular installation. If this equipment does cause harmful interference to radio or television reception, which can be determined by turning the equipment off and on, the user is encouraged to try to correct the interference by one or more of the following measures:

- Reorient or relocate the receiving antenna.
- Increase the separation between the equipment and receiver.
- Connect the equipment into an outlet on a circuit different from that to which the receiver is connected.
- Consult the dealer or an experienced radio/TV technician for help.

Operation is subject to the following two conditions:

- This device may not cause interference and
- This device must accept any interference, including interference that may cause undesired operation of the device.

FCC RF Radiation Exposure Statement:

This equipment complies with FCC radiation exposure limits set forth for an uncontrolled environment. End users must follow the specific operating instructions for satisfying RF exposure compliance. This transmitter must not be co-located or operating in conjunction with any other antenna or transmitter.

Note: The end product shall have the words "*Contains Transmitter Module FCC ID: QQQWT11*"

WT11-A FCC ID: QQQWT11

11.2.1 FCC antenna designation

FCC certified and listed antennas for WT11-E are:

1. EAD MMTX-EA-/)A Bluetooth 2.4GHz SMA M, Dipole Antenna, 2dBi
2. GigAnt Titanis, Dipole Antenna, 4.4dBi
3. EAD MTX-BT-Blade, Dipole Antenna, 2dBi
4. EAD BT-Stubby, Dipole Antenna, 0dBi
5. ACX AT3216, Chip Antenna, 0.5dBi

11.3 CE

WT11 meets the requirements of the standards below and hence fulfills the requirements of EMC Directive 89/336/EEC as amended by Directives 92/31/EEC and 93/68/EEC within CE marking requirement.

- Electromagnetic emission EN 301 489-17 V.1.2.1
 - EN 55022:1998+ A
 - EN 55022:2000+ A3
 - EN 55022:2003 Class B
 - EN 61000-3-2:2001
 - EN 61000-3-3:1995 A1:2001
 - EN 61000-4-3:2002
 - EN 61000-4-4:1995 A1:2000
 - EN 61000-4-5:1995 A1:2000
 - EN 61000-4-6:1996 A1:2000
 - EN 61000-4-11:1994 A1:2000
- ETSI EN 300.328 V1.6.1:2004

11.4 Industry Canada (IC)

WT11 Industry Canada ID: 5123A-BGTWT11E

12. ROHS STATEMENT WITH A LIST OF BANNED MATERIALS

WT11 meets the requirements of Directive 2002/95/EC of the European Parliament and of the Council on the Restriction of Hazardous Substance (RoHS)

The following banned substances are not present in WT11, which is compliant with RoHS:

- Cadmium
- Lead
- Mercury
- Hexavalent chromium
- PBB (Polybrominated Bi-Phenyl)
- PBDE (Polybrominated Diphenyl Ether)

13. CONTACT INFORMATION

Sales: sales@bluegiga.com

Technical support: support@bluegiga.com
<http://www.bluegiga.com/techforum/>

Orders: orders@bluegiga.com

Head Office / Finland

Phone: +358-9-4355 060
Fax: +358-9-4355 0660

Street Address:
Sinikalliontie 11
02630 ESPOO
FINLAND

Postal address:
P.O. BOX 120
02631 ESPOO, FINLAND

Sales Office / USA
Phone: (781) 556-1039

Bluegiga Technologies, Inc.
99 Derby Street, Suite 200
Hingham, MA 02043