

Device Overview

The 89HPES24T3G2 is a member of IDT's PRECISE™ family of PCI Express® switching solutions. The PES24T3G2 is a 24-lane, 3-port Gen2 peripheral chip that performs PCI Express base switching with a feature set optimized for high performance applications such as servers, storage, and communications systems. It provides connectivity and switching functions between a PCI Express upstream port and two downstream ports and supports switching between downstream ports.

Features

- u High Performance PCI Express Switch
 - Twenty-four 5 Gbps Gen2 PCI Express lanes supporting 5 Gbps and 2.5 Gbps operation
 - Up to three switch ports
 - Support for Max Payload Size up to 2048 bytes
 - Supports one virtual channel and eight traffic classes
 - Fully compliant with PCI Express base specification Revision 2.0
- u Flexible Architecture with Numerous Configuration Options
 - Automatic per port link width negotiation to x8, x4, x2, or x1
 - Automatic lane reversal on all ports
 - Automatic polarity inversion
 - Supports in-band hot-plug presence detect capability
 - Supports external signal for hot plug event notification allowing SCI/SMI generation for legacy operating systems

- Dynamic link width reconfiguration for power/performance optimization
- Configurable downstream port PCI-to-PCI bridge device numbering
- Crosslink support
- Supports ARI forwarding defined in the Alternative Routing-ID Interpretation (ARI) ECN for virtualized and non-virtualized environments
- Ability to load device configuration from serial EEPROM
- u Legacy Support
 - PCI compatible INTx emulation
 - Supports bus locked transactions, allowing use of PCI Express with legacy software
- u Highly Integrated Solution
 - Requires no external components
 - Incorporates on-chip internal memory for packet buffering and queueing
 - Integrates twenty-four 5 Gbps / 2.5 Gbps embedded SerDes, 8B/10B encoder/decoder (no separate transceivers needed)
- u Reliability, Availability, and Serviceability (RAS) Features
 - Ability to disable peer-to-peer communications
 - Supports ECRC and Advanced Error Reporting
 - All internal data and control RAMs are SECDED ECC protected
 - Supports PCI Express hot-plug on all downstream ports
 - Supports upstream port hot-plug

Block Diagram

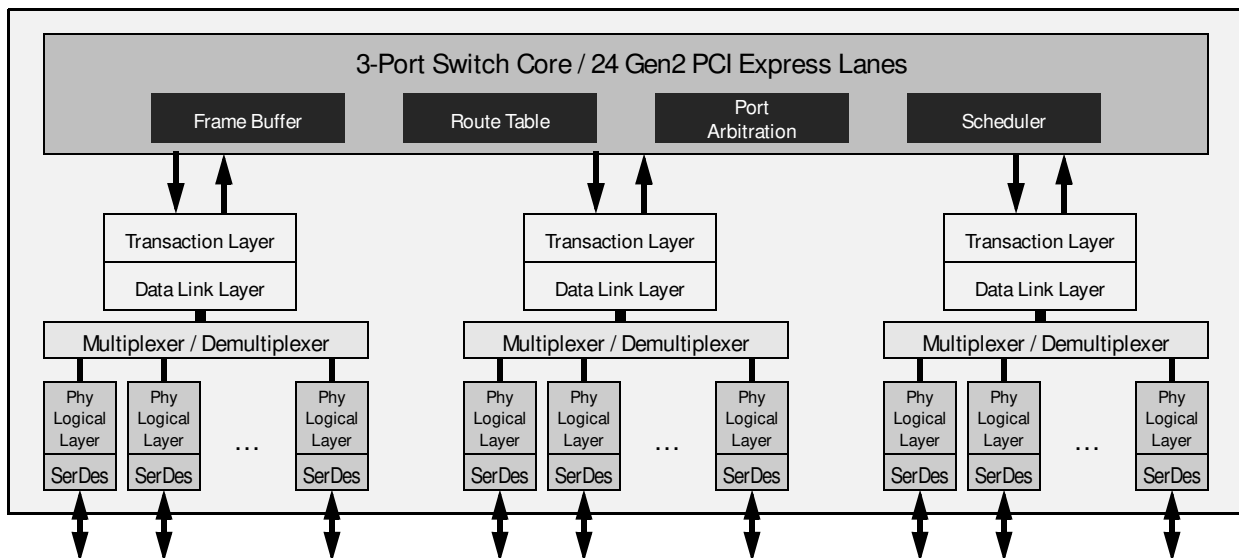

Figure 1 Internal Block Diagram

- Hot-swap capable I/O
- External Serial EEPROM contents are checksum protected
- Supports PCI Express Device Serial Number Capability
- Capability to monitor link reliability and autonomously change link speed to prevent link instability
- u Power Management
 - Utilizes advanced low-power design techniques to achieve low typical power consumption
 - Support PCI Power Management Interface specification (PCI-PM 1.1)
 - Supports device power management states: D0, D3_{hot} and D3_{cold}
 - Support for PCI Express Active State Power Management (ASPM) link state
 - Supports link power management states: L0, L0s, L1, L2/L3 Ready and L3
 - Supports PCI Express Power Budgeting Capability
 - Configurable SerDes power consumption
 - Supports optional PCI-Express SerDes Transmit Low-Swing Voltage Mode
 - Supports numerous SerDes Transmit Voltage Margin settings
 - Unused SerDes are disabled
- u Testability and Debug Features
 - Per port link up and activity status outputs available on I/O expander outputs
 - Built in SerDes 8-bit and 10-bit pseudo-random bit stream (PRBS) generators
 - Numerous SerDes test modes, including a PRBS Master Loopback mode for in-system link testing
 - Ability to read and write any internal register via SMBus and JTAG interfaces, including SerDes internal controls
 - Per port statistics and performance counters, as well as proprietary link status registers
- u General Purpose Input/Output Pins
 - Each pin may be individually configured as an input or output
 - Each pin may be individually configured as an interrupt input
 - Some pins have selectable alternate functions
- u Option A Package: 19mm x 19mm 324-ball Flip Chip BGA with 1mm ball spacing
- u Option B Package: 27mm x 27mm 676-ball Flip Chip BGA with 1mm ball spacing

Product Description

Utilizing standard PCI Express interconnect, the PES24T3G2 provides the most efficient I/O connectivity solution for applications requiring high throughput, low latency, and simple board layout with a minimum number of board layers. It provides connectivity for up to 3 ports across 24 integrated serial lanes. Each lane provides 5 Gbps of bandwidth in both directions and is fully compliant with PCI Express Base Specification, Revision 2.0, including operation in 5 Gbps, 2.5 Gbps, and mixed 5 Gbps / 2.5Gbps modes.

The PES24T3G2 is based on a flexible and efficient layered architecture. The PCI Express layer consists of SerDes, Physical, Data Link and Transaction layers in compliance with PCI Express Base specification

Revision 2.0. The PES24T3G2 can operate either as a store and forward or cut-through switch and is designed to switch memory and I/O transactions. It supports eight Traffic Classes (TCs) and one Virtual Channel (VC) with sophisticated resource management to enable efficient switching and I/O connectivity for servers, storage, and embedded processors with limited connectivity.

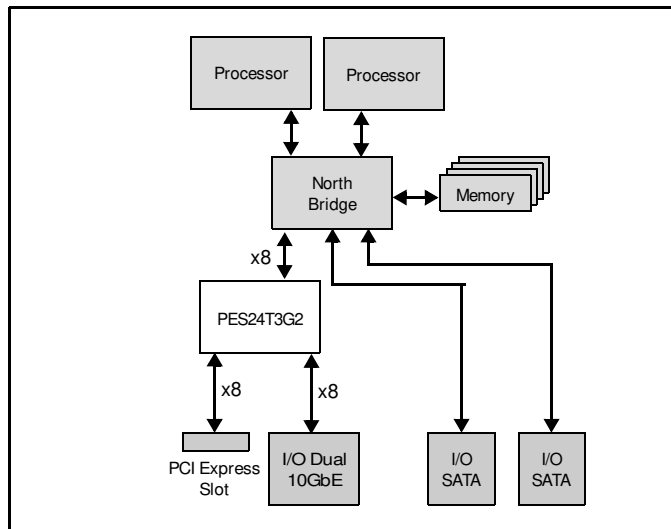

Figure 2 I/O Expansion Application

SMBus Interface

The PES24T3G2 contains two SMBus interfaces. The slave interface provides full access to the configuration registers in the PES24T3G2, allowing every configuration register in the device to be read or written by an external agent. The master interface allows the default configuration register values of the PES24T3G2 to be overridden following a reset with values programmed in an external serial EEPROM. The master interface is also used by an external Hot-Plug I/O expander.

Six pins make up each of the two SMBus interfaces. These pins consist of an SMBus clock pin, an SMBus data pin, and 4 SMBus address pins. In the slave interface, these address pins allow the SMBus address to which the device responds to be configured. In the master interface, these address pins allow the SMBus address of the serial configuration EEPROM from which data is loaded to be configured. The SMBus address is set up on negation of PERSTN by sampling the corresponding address pins. When the pins are sampled, the resulting address is assigned as shown in [Table 1](#).

Note: MSMBADDR and SSMBADDR address pins are not available in the 19mm package. The MSMBADDR address is hardwired to 0x50, and the SSMBADDR address is hardwired to 0x77.

Bit	Slave SMBus Address	Master SMBus Address
1	SSMBADDR[1]	MSMBADDR[1]
2	SSMBADDR[2]	MSMBADDR[2]
3	SSMBADDR[3]	MSMBADDR[3]
4	0	MSMBADDR[4]
5	SSMBADDR[5]	1
6	1	0
7	1	1

Table 1 Master and Slave SMBus Address Assignment for 27x27mm Package

As shown in Figure 3, the master and slave SMBuses may be used in a unified or split configuration. In the unified configuration, shown in Figure 3(a), the master and slave SMBuses are tied together and the PES24T3G2 acts both as a SMBus master as well as a SMBus slave on this bus. This requires that the SMBus master or processor that has access to PES24T3G2 registers supports SMBus arbitration. In some systems, this SMBus master interface may be implemented using general purpose I/O pins on a processor or micro controller, and may not support SMBus arbitration. To support these systems, the PES24T3G2 may be configured to operate in a split configuration as shown in Figure 3(b).

In the split configuration, the master and slave SMBuses operate as two independent buses and thus multi-master arbitration is never required. The PES24T3G2 supports reading and writing of the serial EEPROM on the master SMBus via the slave SMBus, allowing in system programming of the serial EEPROM.

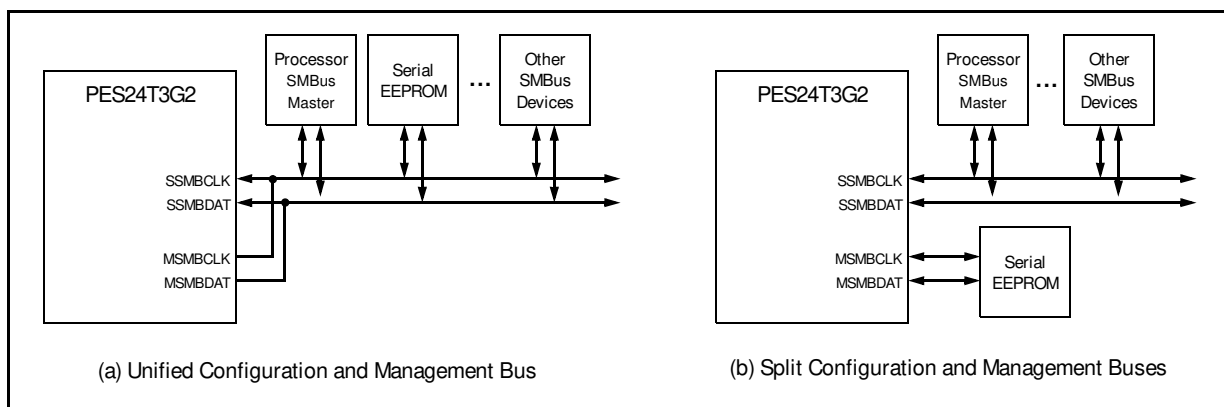

Figure 3 SMBus Interface Configuration Examples

Hot-Plug Interface

The PES24T3G2 supports PCI Express Hot-Plug on each downstream port. To reduce the number of pins required on the device, the PES24T3G2 utilizes an external I/O expander, such as that used on PC motherboards, connected to the SMBus master interface. Following reset and configuration, whenever the state of a Hot-Plug output needs to be modified, the PES24T3G2 generates an SMBus transaction to the I/O expander with the new value of all of the outputs. Whenever a Hot-Plug input changes, the I/O expander generates an interrupt which is received on the IOEXPINTN input pin (alternate function of GPIO) of the PES24T3G2. In response to an I/O expander interrupt, the PES24T3G2 generates an SMBus transaction to read the state of all of the Hot-Plug inputs from the I/O expander.

General Purpose Input/Output

The PES24T3G2 provides General Purpose Input/Output (GPIO) pins (7 pins in the 19mm package and 11 pins in the 27mm package) that may be used by the system designer as bit I/O ports. Each GPIO pin may be configured independently as an input or output through software control. Many GPIO pins are shared with other on-chip functions. These alternate functions may be enabled via software, SMBus slave interface, or serial configuration EEPROM.

Pin Description

The following tables list the functions of the pins provided on the PES24T3G2. Some of the functions listed may be multiplexed onto the same pin. The active polarity of a signal is defined using a suffix. Signals ending with an "N" are defined as being active, or asserted, when at a logic zero (low) level. All other signals (including clocks, buses, and select lines) will be interpreted as being active, or asserted, when at a logic one (high) level.

Note: In the PES24T3G2, the two downstream ports are labeled port 2 and port 4.

Signal	Type	Name/Description
PE0RP[7:0] PE0RN[7:0]	I	PCI Express Port 0 Serial Data Receive. Differential PCI Express receive pairs for port 0. Port 0 is the upstream port.
PE0TP[7:0] PE0TN[7:0]	O	PCI Express Port 0 Serial Data Transmit. Differential PCI Express transmit pairs for port 0. Port 0 is the upstream port.
PE2RP[7:0] PE2RN[7:0]	I	PCI Express Port 2 Serial Data Receive. Differential PCI Express receive pairs for port 2.
PE2TP[7:0] PE2TN[7:0]	O	PCI Express Port 2 Serial Data Transmit. Differential PCI Express transmit pairs for port 2.
PE4RP[7:0] PE4RN[7:0]	I	PCI Express Port 4 Serial Data Receive. Differential PCI Express receive pairs for port 4.
PE4TP[7:0] PE4TN[7:0]	O	PCI Express Port 4 Serial Data Transmit. Differential PCI Express transmit pairs for port 4.
PEREFCLKP PEREFCLKN	I	PCI Express Reference Clock. Differential reference clock pair input. This clock is used as the reference clock by on-chip PLLs to generate the clocks required for the system logic and on-chip SerDes. The frequency of the differential reference clock is determined by the REFCLKM signal.
REFCLKM ¹	I	PCI Express Reference Clock Mode Select. This signal selects the frequency of the reference clock input. 0x0 - 100 MHz 0x1 - 125 MHz This pin should be static and not change following the negation of PERSTN.

Table 2 PCI Express Interface Pins

¹ REFCLKM is not available in the 19mm package and frequency is set at 100MHz.

Signal	Type	Name/Description
MSMBADDR[4:1] ¹	I	Master SMBus Address. These pins determine the SMBus address of the serial EEPROM from which configuration information is loaded.
MSMBCLK	I/O	Master SMBus Clock. This bidirectional signal is used to synchronize transfers on the master SMBus.
MSMBDAT	I/O	Master SMBus Data. This bidirectional signal is used for data on the master SMBus.
SSMBADDR[5,3:1] ²	I	Slave SMBus Address. These pins determine the SMBus address to which the slave SMBus interface responds.
SSMBCLK	I/O	Slave SMBus Clock. This bidirectional signal is used to synchronize transfers on the slave SMBus.

Table 3 SMBus Interface Pins (Part 1 of 2)

Signal	Type	Name/Description
SSMBDAT	I/O	Slave SMBus Data. This bidirectional signal is used for data on the slave SMBus.

Table 3 SMBus Interface Pins (Part 2 of 2)

¹ MSMBADDR pins are not available in the 19mm package. Address hardwired to 0x50.

² SSMBADDR pins are not available in the 19mm package. Address hardwired to 0x77.

Signal	Type	Name/Description
GPIO[0]	I/O	General Purpose I/O. This pin can be configured as a general purpose I/O pin. Alternate function pin name: P2RSTN Alternate function pin type: Output Alternate function: Reset output for downstream port 2
GPIO[1]	I/O	General Purpose I/O. This pin can be configured as a general purpose I/O pin. Alternate function pin name: P4RSTN Alternate function pin type: Output Alternate function: Reset output for downstream port 4
GPIO[2]	I/O	General Purpose I/O. This pin can be configured as a general purpose I/O pin. Alternate function pin name: IOEXPINTN0 Alternate function pin type: Input Alternate function: I/O Expander interrupt 0 input
GPIO[3] ¹	I/O	General Purpose I/O. This pin can be configured as a general purpose I/O pin. Alternate function pin name: IOEXPINTN1 Alternate function pin type: Input Alternate function: I/O Expander interrupt 1 input
GPIO[4] ¹	I/O	General Purpose I/O. This pin can be configured as a general purpose I/O pin. Alternate function pin name: IOEXPINTN2 Alternate function pin type: Input Alternate function: I/O Expander interrupt 2 input
GPIO[5] ¹	I/O	General Purpose I/O. This pin can be configured as a general purpose I/O pin.
GPIO[6] ¹	I/O	General Purpose I/O. This pin can be configured as a general purpose I/O pin.
GPIO[7]	I/O	General Purpose I/O. This pin can be configured as a general purpose I/O pin. Alternate function pin name: GPEN Alternate function pin type: Output Alternate function: General Purpose Event (GPE) output
GPIO[8]	I/O	General Purpose I/O. This pin can be configured as a general purpose I/O pin.
GPIO[9]	I/O	General Purpose I/O. This pin can be configured as a general purpose I/O pin.
GPIO[10]	I/O	General Purpose I/O. This pin can be configured as a general purpose I/O pin.

Table 4 General Purpose I/O Pins

¹ GPIO pins 3, 4, 5, 6 are not available in the 19mm package.

Signal	Type	Name/Description
CCLKDS	I	Common Clock Downstream. The assertion of this pin indicates that all downstream ports are using the same clock source as that provided to downstream devices. This bit is used as the initial value of the Slot Clock Configuration bit in all of the Link Status Registers for downstream ports. The value may be overridden by modifying the SCLK bit in each downstream port's PCIELSTS register.
CCLKUS	I	Common Clock Upstream. The assertion of this pin indicates that the upstream port is using the same clock source as the upstream device. This bit is used as the initial value of the Slot Clock Configuration bit in the Link Status Register for the upstream port. The value may be overridden by modifying the SCLK bit in the P0_PCIEELSTS register.
MSMBSMODE ¹	I	Master SMBus Slow Mode. The assertion of this pin indicates that the master SMBus should operate at 100 KHz instead of 400 KHz. This value may not be overridden.
PERSTN	I	Fundamental Reset. Assertion of this signal resets all logic inside PES24T3G2 and initiates a PCI Express fundamental reset.
RSTHALT ²	I	Reset Halt. When this signal is asserted during a PCI Express fundamental reset, PES24T3G2 executes the reset procedure and remains in a reset state with the Master and Slave SMBuses active. This allows software to read and write registers internal to the device before normal device operation begins. The device exits the reset state when the RSTHALT bit is cleared in the SWCTL register by an SMBus master.
SWMODE[2:0]	I	Switch Mode. These configuration pins determine the PES24T3G2 switch operating mode. 0x0 - Normal switch mode 0x1 - Normal switch mode with Serial EEPROM initialization 0x2 - through 0x7 Reserved These pins should be static and not change following the negation of PERSTN.

Table 5 System Pins

¹ MSMBSMODE is not available in the 19mm package, resulting in the master SMBus operating only at 400 KHz.

² RSTHALT is not available in the 19mm package.

Signal	Type	Name/Description
JTAG_TCK	I	JTAG Clock. This is an input test clock used to clock the shifting of data into or out of the boundary scan logic or JTAG Controller. JTAG_TCK is independent of the system clock with a nominal 50% duty cycle.
JTAG_TDI	I	JTAG Data Input. This is the serial data input to the boundary scan logic or JTAG Controller.
JTAG_TDO	O	JTAG Data Output. This is the serial data shifted out from the boundary scan logic or JTAG Controller. When no data is being shifted out, this signal is tri-stated.
JTAG_TMS	I	JTAG Mode. The value on this signal controls the test mode select of the boundary scan logic or JTAG Controller.

Table 6 Test Pins (Part 1 of 2)

Signal	Type	Name/Description
JTAG_TRST_N	I	JTAG Reset. This active low signal asynchronously resets the boundary scan logic and JTAG TAP Controller. An external pull-up on the board is recommended to meet the JTAG specification in cases where the tester can access this signal. However, for systems running in functional mode, one of the following should occur: 1) actively drive this signal low with control logic 2) statically drive this signal low with an external pull-down on the board

Table 6 Test Pins (Part 2 of 2)

Signal	Type	Name/Description
REFRES0, REFRES1	I/O	Port 0 External Reference Resistors. Provides a reference for the Port 0 SerDes bias currents and PLL calibration circuitry. A 3 kOhm +/- 1% resistor should be connected from these pins to ground.
REFRES2, REFRES3	I/O	Port 2 External Reference Resistors. Provides a reference for the Port 2 SerDes bias currents and PLL calibration circuitry. A 3 kOhm +/- 1% resistor should be connected from these pins to ground.
REFRES4, REFRES5	I/O	Port 4 External Reference Resistors. Provides a reference for the Port 4 SerDes bias currents and PLL calibration circuitry. A 3 kOhm +/- 1% resistor should be connected from these pins to ground.
V _{DD} CORE	I	Core V _{DD} . Power supply for core logic.
V _{DD} I/O	I	I/O V _{DD} . LVTTTL I/O buffer power supply.
V _{DD} PEA	I	PCI Express Analog Power. Serdes analog power supply (1.0V).
V _{DD} PEHA	I	PCI Express Analog High Power. Serdes analog power supply (2.5V).
V _{DD} PETA	I	PCI Express Transmitter Analog Voltage. Serdes transmitter analog power supply (1.0V).
V _{SS}	I	Ground.

Table 7 Power, Ground, and SerDes Resistor Pins

Pin Characteristics

Note: Some input pads of the PES24T3G2 do not contain internal pull-ups or pull-downs. Unused inputs should be tied off to appropriate levels. This is especially critical for unused control signal inputs which, if left floating, could adversely affect operation. Also, any input pin left floating can cause a slight increase in power consumption.

Function	Pin Name	Type	Buffer	I/O Type	Internal Resistor ¹	Notes
PCI Express Interface	PE0RN[7:0]	I	PCIe differential ²	Serial Link		
	PE0RP[7:0]	I				
	PE0TN[7:0]	O				
	PE0TP[7:0]	O				
	PE2RN[7:0]	I				
	PE2RP[7:0]	I				
	PE2TN[7:0]	O				
	PE2TP[7:0]	O				
	PE4RN[7:0]	I				
	PE4RP[7:0]	I				
	PE4TN[7:0]	O				
	PE4TP[7:0]	O				
	PEREFCLKN	I	HCSL	Diff. Clock Input		Refer to Table 9
	PEREFCLKP	I				
	REFCLKM ³	I	LVTTTL	Input	pull-down	
SMBus	MSMBADDR[4:1] ⁴	I	LVTTTL	Input	pull-down	
	MSMBCLK	I/O		STI ⁵		pull-up on board
	MSMBDAT	I/O		STI		pull-up on board
	SSMBADDR[5,3:1] ⁴	I		Input	pull-up	
	SSMBCLK	I/O		STI		pull-up on board
	SSMBDAT	I/O		STI		pull-up on board
General Purpose I/O	GPIO[10:0] ⁶	I/O	LVTTTL	STI, High Drive	pull-up	
System Pins	CCLKDS	I	LVTTTL	Input	pull-up	
	CCLKUS	I		Input	pull-up	
	MSMBSMODE ⁷	I		Input	pull-down	
	PERSTN	I		STI		
	RSTHALT ⁷	I		Input	pull-down	
	SWMODE[2:0]	I		Input	pull-down	
EJTAG / JTAG	JTAG_TCK	I	LVTTTL	STI	pull-up	
	JTAG_TDI	I		STI	pull-up	
	JTAG_TDO	O				
	JTAG_TMS	I		STI	pull-up	
	JTAG_TRST_N	I		STI	pull-up	

Table 8 Pin Characteristics (Part 1 of 2)

Function	Pin Name	Type	Buffer	I/O Type	Internal Resistor ¹	Notes
SerDes Reference Resistors	REFRES0	I/O	Analog			
	REFRES1	I/O				
	REFRES2	I/O				
	REFRES3	I/O				
	REFRES4	I/O				
	REFRES5	I/O				

Table 8 Pin Characteristics (Part 2 of 2)

- ¹. Internal resistor values under typical operating conditions are 92K Ω for pull-up and 90K Ω for pull-down.
- ². All receiver pins set the DC common mode voltage to ground. All transmitters must be AC coupled to the media.
- ³. REFCLKM pin is not available in the 19mm package.
- ⁴. SMBus address pins are not available in the 19mm package.
- ⁵. Schmitt Trigger Input (STI).
- ⁶. GPIO pins 3, 4, 5, 6 are not available in the 19mm package.
- ⁷. MSMBSMODE and RSTHALT are not available in the 19mm package.

Logic Diagram — PES24T3G2

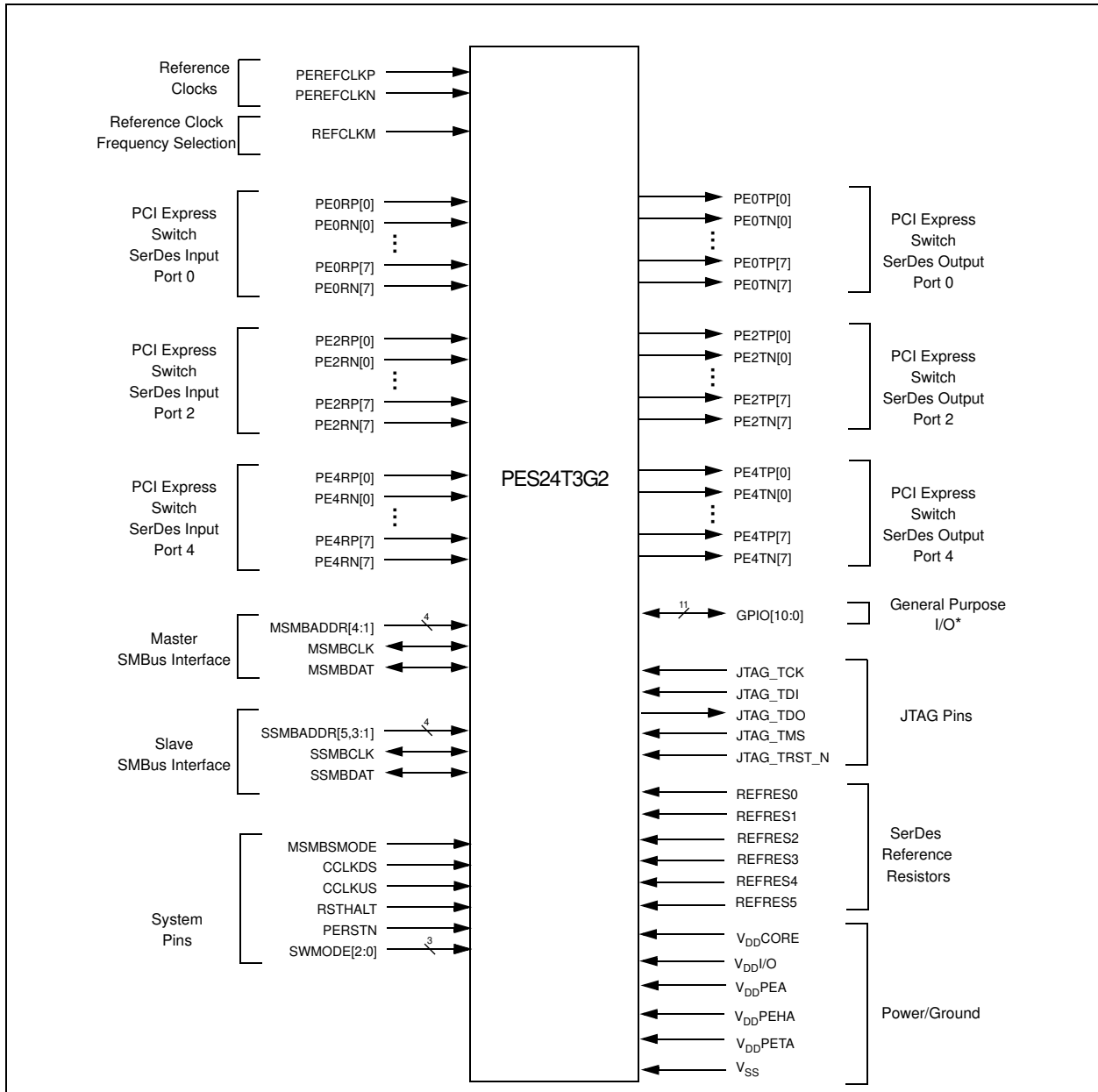

Figure 4 PES24T3G2 Logic Diagram

Note: The following pins are not available in the 19mm package: REFCLKM, MSMBADDR, SSMBADDR, MSMBSMODE, RSTHALT, GPIO[6:3].

System Clock Parameters

Values based on systems running at recommended supply voltages and operating temperatures, as shown in Tables 13 and 15.

Parameter	Description	Condition	Min	Typical	Max	Unit
Refclk _{FREQ}	Input reference clock frequency range		100		125 ¹	MHz
T _{C-RISE}	Rising edge rate	Differential	0.6		4	V/ns
T _{C-FALL}	Falling edge rate	Differential	0.6		4	V/ns
V _{IH}	Differential input high voltage	Differential	+150			mV
V _{IL}	Differential input low voltage	Differential			-150	mV
V _{CROSS}	Absolute single-ended crossing point voltage	Single-ended	+250		+550	mV
V _{CROSS-DELTA}	Variation of V _{CROSS} over all rising clock edges	Single-ended			+140	mV
V _{RB}	Ring back voltage margin	Differential	-100		+100	mV
T _{STABLE}	Time before V _{RB} is allowed	Differential	500			ps
T _{PERIOD-AVG}	Average clock period accuracy		-300		2800	ppm
T _{PERIOD-ABS}	Absolute period, including spread-spectrum and jitter		9.847		10.203	ns
T _{CC-JITTER}	Cycle to cycle jitter				150	ps
V _{MAX}	Absolute maximum input voltage				+1.15	V
V _{MIN}	Absolute minimum input voltage		-0.3			V
Duty Cycle	Duty cycle		40		60	%
Rise/Fall Matching	Single ended rising Refclk edge rate versus falling Refclk edge rate			20		%
Z _{C-DC}	Clock source output DC impedance		40		60	Ω

Table 9 Input Clock Requirements

¹ The input clock frequency will be either 100 or 125 MHz depending on signal REFCLKM. Frequency is set at 100 MHz in the 19mm package.

AC Timing Characteristics

Parameter	Description	Gen 1			Gen 2			Units
		Min ¹	Typ ¹	Max ¹	Min ¹	Typ ¹	Max ¹	
PCIe Transmit								
UI	Unit Interval	399.88	400	400.12	199.94	200	200.06	ps
T _{TX-EYE}	Minimum Tx Eye Width	0.75			0.75			UI
T _{TX-EYE-MEDIAN-to-MAX-JITTER}	Maximum time between the jitter median and maximum deviation from the median			0.125				UI
T _{TX-RISE} , T _{TX-FALL}	TX Rise/Fall Time: 20% - 80%	0.125			0.15			UI
T _{TX-IDLE-MIN}	Minimum time in idle	20			20			UI

Table 10 PCIe AC Timing Characteristics (Part 1 of 2)

Parameter	Description	Gen 1			Gen 2			Units
		Min ¹	Typ ¹	Max ¹	Min ¹	Typ ¹	Max ¹	
T _{TX-IDLE-SET-TO-IDLE}	Maximum time to transition to a valid Idle after sending an Idle ordered set			8			8	ns
T _{TX-IDLE-TO-DIFF-DATA}	Maximum time to transition from valid idle to diff data			8			8	ns
T _{TX-SKEW}	Transmitter data skew between any 2 lanes			1.3			1.3	ns
T _{MIN-PULSED}	Minimum Instantaneous Lone Pulse Width	NA			0.9			UI
T _{TX-HF-DJ-DD}	Transmitter Deterministic Jitter > 1.5MHz Bandwidth	NA					0.15	UI
T _{RF-MISMATCH}	Rise/Fall Time Differential Mismatch	NA					0.1	UI
PCIe Receive								
UI	Unit Interval	399.88	400	400.12	199.94		200.06	ps
T _{RX-EYE (with jitter)}	Minimum Receiver Eye Width (jitter tolerance)	0.4			0.4			UI
T _{RX-EYE-MEDIUM TO MAX JITTER}	Max time between jitter median & max deviation			0.3				UI
T _{RX-SKEW}	Lane to lane input skew			20			8	ns
T _{RX-HF-RMS}	1.5 — 100 MHz RMS jitter (common clock)	NA					3.4	ps
T _{RX-HF-DJ-DD}	Maximum tolerable DJ by the receiver (common clock)	NA					88	ps
T _{RX-LF-RMS}	10 KHz to 1.5 MHz RMS jitter (common clock)	NA					4.2	ps
T _{RX-MIN-PULSE}	Minimum receiver instantaneous eye width	NA			0.6			UI

Table 10 PCIe AC Timing Characteristics (Part 2 of 2)

¹ Minimum, Typical, and Maximum values meet the requirements under PCI Specification 2.0

Signal	Symbol	Reference Edge	Min	Max	Unit	Timing Diagram Reference
GPIO						
GPIO[10:0] ¹	T _{pw} ²	None	50	—	ns	

Table 11 GPIO AC Timing Characteristics

¹ GPIO signals must meet the setup and hold times if they are synchronous or the minimum pulse width if they are asynchronous. Note that GPIO[6:3] pins are not available in the 19mm package.

² The values for this symbol were determined by calculation, not by testing.

Signal	Symbol	Reference Edge	Min	Max	Unit	Timing Diagram Reference
JTAG						
JTAG_TCK	Tper_16a	none	50.0	—	ns	See Figure 5 .
	Thigh_16a, Tlow_16a		10.0	25.0	ns	
JTAG_TMS ¹ , JTAG_TDI	Tsu_16b	JTAG_TCK rising	2.4	—	ns	
	Thld_16b		1.0	—	ns	
JTAG_TDO	Tdo_16c	JTAG_TCK falling	—	20	ns	
	Tdz_16c ²		—	20	ns	
JTAG_TRST_N	Tpw_16d ²	none	25.0	—	ns	

Table 12 JTAG AC Timing Characteristics

¹ The JTAG specification, IEEE 1149.1, recommends that JTAG_TMS should be held at 1 while the signal applied at JTAG_TRST_N changes from 0 to 1. Otherwise, a race may occur if JTAG_TRST_N is deasserted (going from low to high) on a rising edge of JTAG_TCK when JTAG_TMS is low, because the TAP controller might go to either the Run-Test/Idle state or stay in the Test-Logic-Reset state.

² The values for this symbol were determined by calculation, not by testing.

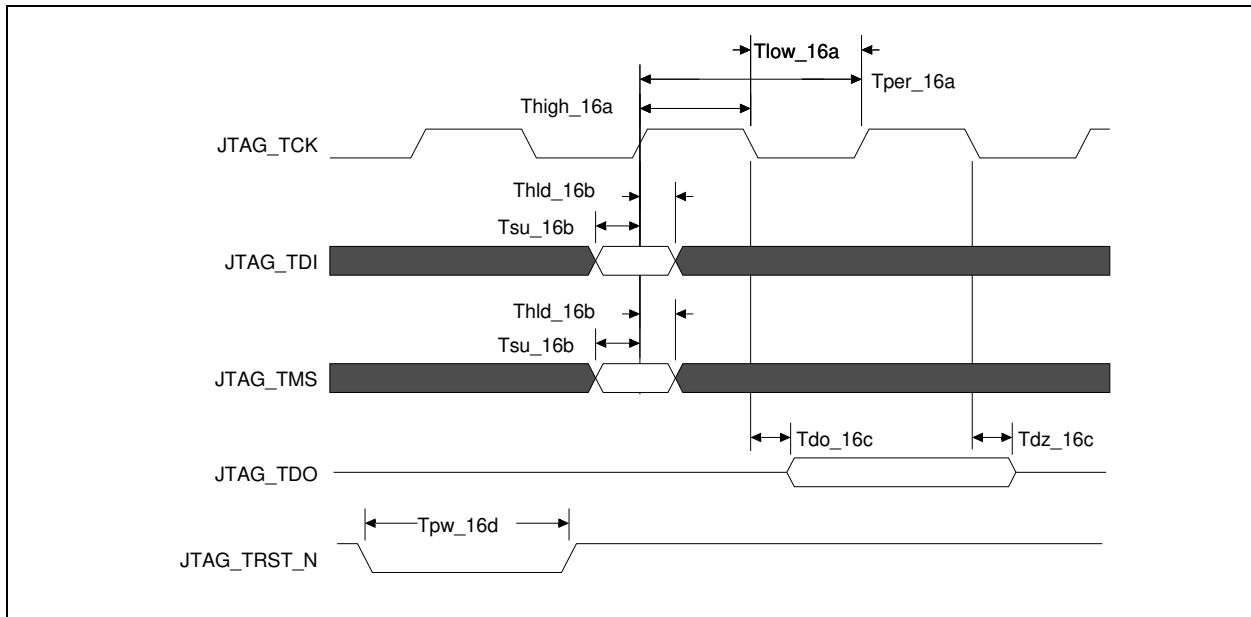

Figure 5 JTAG AC Timing Waveform

Recommended Operating Supply Voltages

Symbol	Parameter	Minimum	Typical	Maximum	Unit
V _{DD} CORE	Internal logic supply	0.9	1.0	1.1	V
V _{DD} I/O	I/O supply except for SerDes LVPECL/CML	3.135	3.3	3.465	V
V _{DD} PEA ¹	PCI Express Analog Power	0.95	1.0	1.1	V
V _{DD} PEHA ²	PCI Express Analog High Power	2.25	2.5	2.75	V
V _{DD} PETA ¹	PCI Express Transmitter Analog Voltage	0.95	1.0	1.1	V
V _{SS}	Common ground	0	0	0	V

Table 13 PES24T3G2 Operating Voltages

¹ V_{DD}PEA and V_{DD}PETA should have no more than 25mV_{peak-peak} AC power supply noise superimposed on the 1.0V nominal DC value.

² V_{DD}PEHA should have no more than 50mV_{peak-peak} AC power supply noise superimposed on the 2.5V nominal DC value.

Absolute Maximum Voltage Rating

Core Supply	PCIe Analog Supply	PCIe Analog High Supply	PCIe Transmitter Supply	I/O Supply
1.5V	1.5V	4.6V	1.5V	4.6V

Table 14 PES24T3G2 Absolute Maximum Voltage Rating

Warning: For proper and reliable operation in adherence with this data sheet, the device should not exceed the recommended operating voltages in Table 13. The absolute maximum operating voltages in Table 14 are offered to provide guidelines for voltage excursions outside the recommended voltage ranges. Device functionality is not guaranteed at these conditions and sustained operation at these values or any exposure to voltages outside the maximum range may adversely affect device functionality and reliability.

Power-Up/Power-Down Sequence

During power supply ramp-up, V_{DD}CORE must remain at least 1.0V below V_{DD}I/O at all times. There are no other power-up sequence requirements for the various operating supply voltages.

The power-down sequence can occur in any order.

Recommended Operating Temperature

Grade	Temperature
Commercial	0°C to +70°C Ambient
Industrial	-40°C to +85°C Ambient

Table 15 PES24T3G2 Operating Temperatures

Power Consumption

Typical power is measured under the following conditions: 25°C Ambient, 35% total link usage on all ports, typical voltages defined in [Table 13](#) (and also listed below).

Maximum power is measured under the following conditions: 70°C Ambient, 85% total link usage on all ports, maximum voltages defined in [Table 13](#) (and also listed below).

Number of Active Lanes per Port		Core Supply		PCIe Analog Supply		PCIe Analog High Supply		PCIe Termination Supply		I/O Supply		Total	
		Typ 1.0V	Max 1.1V	Typ 1.0V	Max 1.1V	Typ 2.5V	Max 2.75V	Typ 1.0V	Max 1.15V	Typ 3.3V	Max 3.465V	Typ Power	Max Power
8/8/8 (Full Swing)	mA	1010	1260	1384	1600	161	176	541	600	3	5		
	Watts	1.01	1.39	1.38	1.76	0.40	0.48	0.54	0.66	0.010	0.017	3.35	4.31
88/8 (Half Swing)	mA	1010	1260	1190	1376	161	176	281	312	3	5		
	Watts	1.01	1.39	1.19	1.51	0.40	0.48	0.28	0.34	0.010	0.017	2.89	3.74

Table 16 PES24T3G2 Power Consumption

Thermal Considerations — Option A Package

This section describes thermal considerations for the PES24T3G2 (19mm² FCBGA324 package). The data in [Table 17](#) below contains information that is relevant to the thermal performance of the PES24T3G2 switch.

Symbol	Parameter	Value	Units	Conditions
$T_{J(max)}$	Junction Temperature	125	°C	Maximum
$T_{A(max)}$	Ambient Temperature	70	°C	Maximum
$\theta_{JA(effective)}$	Effective Thermal Resistance, Junction-to-Ambient	16.8	°C/W	Zero air flow
		10.1	°C/W	1 m/S air flow
		9.2	°C/W	2 m/S air flow
θ_{JB}	Thermal Resistance, Junction-to-Board	4.1	°C/W	
θ_{JC}	Thermal Resistance, Junction-to-Case	0.3	°C/W	
P	Power Dissipation of the Device	4.31	Watts	Maximum

Table 17 Thermal Specifications for PES24T3G2, 19x19 mm FCBGA324 Package

Thermal Considerations — Option B Package

This section describes thermal considerations for the PES24T3G2 (27mm² FCBGA676 package). The data in [Table 18](#) below contains information that is relevant to the thermal performance of the PES24T3G2 switch.

Symbol	Parameter	Value	Units	Conditions
$T_{J(max)}$	Junction Temperature	125	°C	Maximum
$T_{A(max)}$	Ambient Temperature	70	°C	Maximum
$\theta_{JA(effective)}$	Effective Thermal Resistance, Junction-to-Ambient	14.6	°C/W	Zero air flow
		8.2	°C/W	1 m/S air flow
		7.2	°C/W	2 m/S air flow
θ_{JB}	Thermal Resistance, Junction-to-Board	3.1	°C/W	
θ_{JC}	Thermal Resistance, Junction-to-Case	0.3	°C/W	
P	Power Dissipation of the Device	4.31	Watts	Maximum

Table 18 Thermal Specifications for PES24T3G2, 27x27 mm FCBGA676 Package

Note: It is important for the reliability of this device in any user environment that the junction temperature not exceed the $T_{J(max)}$ value specified in [Table 17](#). Consequently, the effective junction to ambient thermal resistance (θ_{JA}) for the worst case scenario must be maintained below the value determined by the formula:

$$\theta_{JA} = (T_{J(max)} - T_{A(max)})/P$$

Given that the values of $T_{J(max)}$, $T_{A(max)}$, and P are known, the value of desired θ_{JA} becomes a known entity to the system designer. How to achieve the desired θ_{JA} is left up to the board or system designer, but in general, it can be achieved by adding the effects of θ_{JC} (value provided in [Table 17](#)), thermal resistance of the chosen adhesive (θ_{CS}), that of the heat sink (θ_{SA}), amount of airflow, and properties of the circuit board (number of layers and size of the board). As a general guideline, this device will not need a heat sink if the board has 8 or more layers AND the board size is larger than 4"x12" AND airflow in excess of 0.5 m/s is available. It is strongly recommended that users perform their own thermal analysis for their own board and system design scenarios.

DC Electrical Characteristics

Values based on systems running at recommended supply voltages, as shown in [Table 13](#).

Note: See [Table 8](#), Pin Characteristics, for a complete I/O listing.

I/O Type	Parameter	Description	Gen1			Gen2			Unit	Condi- tions
			Min ¹	Typ ¹	Max ¹	Min ¹	Typ ¹	Max ¹		
Serial Link	PCIe Transmit									
	V _{TX-DIFFP-p}	Differential peak-to-peak output voltage	800		1200	800		1200	mV	
	V _{TX-DIFFP-p-LOW}	Low-Drive Differential Peak to Peak Output Voltage	400		1200	400		1200	mV	
	V _{TX-DE-RATIO-3.5dB}	De-emphasized differential output voltage	-3		-4	-3.0	-3.5	-4.0	dB	
	V _{TX-DE-RATIO-6.0dB}	De-emphasized differential output voltage	NA			-5.5	-6.0	-6.5	dB	
	V _{TX-DC-CM}	DC Common mode voltage	0		3.6	0		3.6	V	
	V _{TX-CM-ACP}	RMS AC peak common mode output voltage			20				mV	
	V _{TX-CM-DC-active-idle-delta}	Abs delta of DC common mode voltage between L0 and idle			100			100	mV	
	V _{TX-CM-DC-line-delta}	Abs delta of DC common mode voltage between D+ and D-			25			25	mV	
	V _{TX-Idle-DiffP}	Electrical idle diff peak output			20			20	mV	
	RL _{TX-DIFF}	Transmitter Differential Return loss	10					10	dB	0.05 - 1.25GHz
									8	dB
	RL _{TX-CM}	Transmitter Common Mode Return loss	6					6	dB	
	Z _{TX-DIFF-DC}	DC Differential TX impedance	80	100	120			120	Ω	
	V _{TX-CM-ACpp}	Peak-Peak AC Common	NA					100	mV	
V _{TX-DC-CM}	Transmit Driver DC Common Mode Voltage	0		3.6	0		3.6	V		
V _{TX-RCV-DETECT}	The amount of voltage change allowed during Receiver Detection			600			600	mV		
I _{TX-SHORT}	Transmitter Short Circuit Current Limit	0		90				90	mA	

Table 19 DC Electrical Characteristics (Part 1 of 2)

I/O Type	Parameter	Description	Gen1			Gen2			Unit	Condi- tions
			Min ¹	Typ ¹	Max ¹	Min ¹	Typ ¹	Max ¹		
Serial Link (cont.)	PCIe Receive									
	$V_{RX-DIFFp-p}$	Differential input voltage (peak-to-peak)	175		1200	120		1200	mV	
	$RL_{RX-DIFF}$	Receiver Differential Return Loss	10					10	dB	0.05 - 1.25GHz
								8		1.25 - 2.5GHz
	RL_{RX-CM}	Receiver Common Mode Return Loss	6					6	dB	
	$Z_{RX-DIFF-DC}$	Differential input impedance (DC)	80	100	120	Refer to return loss spec			Ω	
	Z_{RX--DC}	DC common mode impedance	40	50	60	40		60	Ω	
	$Z_{RX-COMM-DC}$	Powered down input common mode impedance (DC)	200k	350k				50k	Ω	
	$Z_{RX-HIGH-IMP-DC-POS}$	DC input CM input impedance for $V > 0$ during reset or power down			50k			50k	Ω	
	$Z_{RX-HIGH-IMP-DC-NEG}$	DC input CM input impedance for $V < 0$ during reset or power down			1.0k			1.0k	Ω	
$V_{RX-IDLE-DET-DIFFp-p}$	Electrical idle detect threshold	65		175	65		175	mV		
$V_{RX-CM-ACp}$	Receiver AC common-mode peak voltage			150			150	mV	$V_{RX-CM-ACp}$	
PCIe REFCLK										
	C_{IN}	Input Capacitance	1.5	—		1.5	—		pF	
Other I/Os										
LOW Drive Output	I_{OL}		—	2.5	—	—	2.5	—	mA	$V_{OL} = 0.4v$
	I_{OH}		—	-5.5	—	—	-5.5	—	mA	$V_{OH} = 1.5V$
High Drive Output	I_{OL}		—	12.0	—	—	12.0	—	mA	$V_{OL} = 0.4v$
	I_{OH}		—	-20.0	—	—	-20.0	—	mA	$V_{OH} = 1.5V$
Schmitt Trig- ger Input (STI)	V_{IL}		-0.3	—	0.8	-0.3	—	0.8	V	—
	V_{IH}		2.0	—	$V_{DD}/O + 0.5$	2.0	—	$V_{DD}/O + 0.5$	V	—
Input	V_{IL}		-0.3	—	0.8	-0.3	—	0.8	V	—
	V_{IH}		2.0	—	$V_{DD}/O + 0.5$	2.0	—	$V_{DD}/O + 0.5$	V	—
Capacitance	C_{IN}		—	—	8.5	—	—	8.5	pF	—
Leakage	Inputs		—	—	± 10	—	—	± 10	μA	V_{DD}/O (max)
	I/O_{LEAK} W/O Pull-ups/downs		—	—	± 10	—	—	± 10	μA	V_{DD}/O (max)
	I/O_{LEAK} WITH Pull-ups/downs		—	—	± 80	—	—	± 80	μA	V_{DD}/O (max)

Table 19 DC Electrical Characteristics (Part 2 of 2)

¹ Minimum, Typical, and Maximum values meet the requirements under PCI Specification 2.0.

Option A Package Pinout, 19x19mm 324-BGA Signal Pinout

The following table lists the pin numbers and signal names for the PES24T3G2 device.

Pin	Function	Alt	Pin	Function	Alt	Pin	Function	Alt	Pin	Function	Alt
A1	V _{SS}		B17	PE4TN00		D15	V _{DD} CORE		F13	V _{SS}	
A2	V _{DD} /O		B18	PE4TP00		D16	V _{SS}		F14	PE4RN03	
A3	V _{SS}		C1	PE2TP06		D17	V _{SS}		F15	PE4RP03	
A4	V _{SS}		C2	PE2TN06		D18	V _{SS}		F16	V _{SS}	
A5	V _{SS}		C3	V _{SS}		E1	PE2TP05		F17	PE4TN03	
A6	V _{DD} /O		C4	PE2RP06		E2	PE2TN05		F18	PE4TP03	
A7	V _{SS}		C5	PE2RN06		E3	V _{SS}		G1	V _{SS}	
A8	JTAG_TDI		C6	V _{SS}		E4	PE2RP05		G2	V _{SS}	
A9	MSMBDAT		C7	JTAG_TCK		E5	PE2RN05		G3	V _{SS}	
A10	V _{DD} /O		C8	JTAG_TRST_N		E6	V _{DD} CORE		G4	V _{DD} CORE	
A11	V _{SS}		C9	SSMBDAT		E7	V _{DD} CORE		G5	V _{DD} CORE	
A12	GPIO_00	1	C10	CCLKDS		E8	V _{DD} CORE		G6	V _{DD} PEA	
A13	V _{DD} /O		C11	SWMODE_2		E9	V _{SS}		G7	V _{DD} PEA	
A14	V _{DD} /O		C12	GPIO_02		E10	V _{DD} CORE		G8	V _{DD} CORE	
A15	V _{SS}		C13	GPIO_09		E11	V _{DD} CORE		G9	V _{DD} CORE	
A16	V _{SS}		C14	PE4RN01		E12	V _{DD} CORE		G10	V _{DD} CORE	
A17	V _{DD} /O		C15	PE4RP01		E13	V _{DD} CORE		G11	V _{SS}	
A18	V _{DD} /O		C16	V _{SS}		E14	PE4RN02		G12	V _{DD} PEA	
B1	PE2TP07		C17	PE4TN01		E15	PE4RP02		G13	V _{DD} PEA	
B2	PE2TN07		C18	PE4TP01		E16	V _{SS}		G14	V _{DD} CORE	
B3	V _{SS}		D1	V _{SS}		E17	PE4TN02		G15	V _{DD} CORE	
B4	PE2RP07		D2	V _{SS}		E18	PE4TP02		G16	V _{SS}	
B5	PE2RN07		D3	V _{SS}		F1	PE2TP04		G17	V _{SS}	
B6	V _{DD} /O		D4	V _{DD} CORE		F2	PE2TN04		G18	V _{SS}	
B7	V _{SS}		D5	V _{DD} CORE		F3	V _{SS}		H1	PE2TP03	
B8	JTAG_TMS		D6	V _{DD} /O		F4	PE2RP04		H2	PE2TN03	
B9	SSMBCLK		D7	JTAG_TDO		F5	PE2RN04		H3	V _{SS}	
B10	V _{DD} /O		D8	MSMBCLK		F6	V _{SS}		H4	PE2RP03	
B11	SWMODE_1		D9	CCLKUS		F7	V _{SS}		H5	PE2RN03	
B12	GPIO_01	1	D10	SWMODE_0		F8	V _{DD} CORE		H6	V _{DD} PEA	
B13	GPIO_10		D11	PERSTN		F9	V _{SS}		H7	V _{DD} PEA	
B14	PE4RN00		D12	GPIO_07	1	F10	V _{DD} CORE		H8	V _{DD} CORE	
B15	PE4RP00		D13	GPIO_08		F11	V _{SS}		H9	V _{DD} CORE	
B16	V _{SS}		D14	V _{DD} CORE		F12	V _{SS}		H10	V _{DD} CORE	

Table 20 PES24T3G2 (19x19mm 324-pin) Signal Pin-Out (Part 1 of 3)

Pin	Function	Alt	Pin	Function	Alt	Pin	Function	Alt	Pin	Function	Alt
H11	V _{SS}		K13	V _{DD} PETA		M15	PE4RP07		P17	V _{DD} CORE	
H12	V _{DD} PEA		K14	V _{DD} CORE		M16	V _{SS}		P18	V _{SS}	
H13	V _{DD} PEA		K15	NC		M17	PE4TN07		R1	V _{SS}	
H14	PE4RN04		K16	V _{SS}		M18	PE4TP07		R2	V _{DD} CORE	
H15	PE4RP04		K17	REFRES5		N1	V _{SS}		R3	V _{DD} CORE	
H16	V _{SS}		K18	REFRES4		N2	V _{SS}		R4	PE0RP07	
H17	PE4TN04		L1	PE2TP01		N3	V _{SS}		R5	PE0RP06	
H18	PE4TP04		L2	PE2TN01		N4	V _{DD} CORE		R6	NC	
J1	PE2TP02		L3	V _{SS}		N5	V _{DD} CORE		R7	PE0RP05	
J2	PE2TN02		L4	PE2RP01		N6	V _{SS}		R8	PE0RP04	
J3	V _{SS}		L5	PE2RN01		N7	V _{SS}		R9	V _{DD} CORE	
J4	PE2RP02		L6	V _{DD} PETA		N8	V _{DD} PEA		R10	PE0RP03	
J5	PE2RN02		L7	V _{DD} PETA		N9	V _{DD} PEHA		R11	PE0RP02	
J6	V _{DD} PEHA		L8	V _{DD} PEA		N10	V _{DD} PETA		R12	V _{DD} CORE	
J7	V _{DD} PEHA		L9	V _{DD} PEHA		N11	V _{DD} PEA		R13	PE0RP01	
J8	V _{DD} CORE		L10	V _{DD} PETA		N12	V _{DD} PEHA		R14	PE0RP00	
J9	V _{SS}		L11	V _{DD} PEA		N13	V _{SS}		R15	V _{DD} CORE	
J10	V _{DD} CORE		L12	V _{DD} PEHA		N14	V _{SS}		R16	V _{DD} CORE	
J11	V _{SS}		L13	V _{DD} PETA		N15	V _{DD} CORE		R17	V _{DD} CORE	
J12	V _{DD} PEHA		L14	PE4RN06		N16	V _{SS}		R18	V _{SS}	
J13	V _{DD} PEHA		L15	PE4RP06		N17	V _{SS}		T1	V _{SS}	
J14	PE4RN05		L16	V _{SS}		N18	V _{SS}		T2	V _{SS}	
J15	PE4RP05		L17	PE4TN06		P1	V _{SS}		T3	V _{SS}	
J16	V _{SS}		L18	PE4TP06		P2	V _{DD} CORE		T4	V _{SS}	
J17	PE4TN05		M1	PE2TP00		P3	V _{DD} CORE		T5	V _{SS}	
J18	PE4TP05		M2	PE2TN00		P4	PE0RN07		T6	V _{SS}	
K1	REFRES2		M3	V _{SS}		P5	PE0RN06		T7	V _{SS}	
K2	REFRES3		M4	PE2RP00		P6	V _{DD} CORE		T8	V _{SS}	
K3	V _{SS}		M5	PE2RN00		P7	PE0RN05		T9	V _{SS}	
K4	V _{DD} CORE		M6	V _{DD} PETA		P8	PE0RN04		T10	V _{SS}	
K5	V _{DD} CORE		M7	V _{DD} PETA		P9	V _{DD} CORE		T11	V _{SS}	
K6	V _{DD} PETA		M8	V _{DD} PEA		P10	PE0RN03		T12	V _{SS}	
K7	V _{DD} PETA		M9	V _{DD} PEHA		P11	PE0RN02		T13	V _{SS}	
K8	V _{DD} CORE		M10	V _{DD} PETA		P12	V _{DD} CORE		T14	V _{SS}	
K9	V _{SS}		M11	V _{DD} PEA		P13	PE0RN01		T15	V _{SS}	
K10	V _{DD} CORE		M12	V _{DD} PEHA		P14	PE0RN00		T16	V _{SS}	
K11	V _{SS}		M13	V _{SS}		P15	V _{DD} CORE		T17	V _{SS}	
K12	V _{DD} PETA		M14	PE4RN07		P16	V _{DD} CORE		T18	V _{SS}	

Table 20 PES24T3G2 (19x19mm 324-pin) Signal Pin-Out (Part 2 of 3)

Pin	Function	Alt	Pin	Function	Alt	Pin	Function	Alt	Pin	Function	Alt
U1	V _{SS}		U10	PE0TN03		V1	V _{SS}		V10	PE0TP03	
U2	PEREFCLKN		U11	PE0TN02		V2	PEREFCLKP		V11	PE0TP02	
U3	V _{SS}		U12	V _{SS}		V3	V _{SS}		V12	V _{SS}	
U4	PE0TN07		U13	PE0TN01		V4	PE0TP07		V13	PE0TP01	
U5	PE0TN06		U14	PE0TN00		V5	PE0TP06		V14	PE0TP00	
U6	REFRES1		U15	V _{SS}		V6	REFRES0		V15	V _{SS}	
U7	PE0TN05		U16	V _{SS}		V7	PE0TP05		V16	V _{SS}	
U8	PE0TN04		U17	V _{SS}		V8	PE0TP04		V17	V _{SS}	
U9	V _{SS}		U18	V _{SS}		V9	V _{SS}		V18	V _{SS}	

Table 20 PES24T3G2 (19x19mm 324-pin) Signal Pin-Out (Part 3 of 3)

Option A Package Power Pins (19x19mm 324-Pin)

V _{DD} Core	V _{DD} Core	V _{DD} Core	V _{DD} I/O	V _{DD} PEA	V _{DD} PEHA	V _{DD} PETA
D4	G9	N15	A2	G6	J6	K6
D5	G10	P2	A6	G7	J7	K7
D14	G14	P3	A10	G12	J12	K12
D15	G15	P6	A13	G13	J13	K13
E6	H8	P9	A14	H6	L9	L6
E7	H9	P12	A17	H7	L12	L7
E8	H10	P15	A18	H12	M9	L10
E10	J8	P16	B6	H13	M12	L13
E11	J10	P17	B10	L8	N9	M6
E12	K4	R2	D6	L11	N12	M7
E13	K5	R3		M8		M10
F8	K8	R9		M11		N10
F10	K10	R12		N8		
G4	K14	R15		N11		
G5	N4	R16				
G8	N5	R17				

Table 21 PES24T3G2 (19x19mm 324-Pin) Power Pins

Option A Package Ground Pins (19x19mm 324-Pin)

V _{SS}	V _{SS}	V _{SS}	V _{SS}	V _{SS}	V _{SS}
A1	D16	G11	M3	T1	T18
A3	D17	G16	M13	T2	U1
A4	D18	G17	M16	T3	U3
A5	E3	G18	N1	T4	U9
A7	E9	H3	N2	T5	U12
A11	E16	H11	N3	T6	U15
A15	F3	H16	N6	T7	U16
A16	F6	J3	N7	T8	U17
B3	F7	J9	N13	T9	U18
B7	F9	J11	N14	T10	V1
B16	F11	J16	N16	T11	V3
C3	F12	K3	N17	T12	V9
C6	F13	K9	N18	T13	V12
C16	F16	K11	P1	T14	V15
D1	G1	K16	P18	T15	V16
D2	G2	L3	R1	T16	V17
D3	G3	L16	R18	T17	V18

Table 22 PES24T3G2 (19x19mm 324-Pin) Ground Pins

Option A Package Alternate Signal Functions (19x19mm 324-Pin)

Pin	GPIO	Alternate
A12	GPIO_00	P2RSTN
B12	GPIO_01	P4RSTN
C12	GPIO_02	IOEXPINTN0
D12	GPIO_07	GPEN

Table 23 PES24T3G2 (19x19mm 324-Pin) Alternate Signal Functions

Option A Package Signals Listed Alphabetically (19x19mm 324-Pin)

Signal Name	I/O Type	Location	Signal Category
CCLKDS	I	C10	System
CCLKUS	I	D9	
GPIO_00	I/O	A12	General Purpose Input/Output
GPIO_01	I/O	B12	
GPIO_02	I/O	C12	
GPIO_07	I/O	D12	
GPIO_08	I/O	D13	
GPIO_09	I/O	C13	
GPIO_10	I/O	B13	
JTAG_TCK	I	C7	
JTAG_TDI	I	A8	
JTAG_TDO	O	D7	
JTAG_TMS	I	B8	
JTAG_TRST_N	I	C8	
MSMBCLK	I/O	D8	SMBus
MSMBDAT	I/O	A9	
NO CONNECT		K15, R6	
PE0RN00	I	P14	PCI Express
PE0RN01	I	P13	
PE0RN02	I	P11	
PE0RN03	I	P10	
PE0RN04	I	P8	
PE0RN05	I	P7	
PE0RN06	I	P5	
PE0RN07	I	P4	
PE0RP00	I	R14	
PE0RP01	I	R13	
PE0RP02	I	R11	
PE0RP03	I	R10	
PE0RP04	I	R8	
PE0RP05	I	R7	
PE0RP06	I	R5	
PE0RP07	I	R4	
PE0TN00	O	U14	

Table 24 PES24T3G2 (19x19mm 324-Pin) Alphabetical Signal List (Part 1 of 4)

Signal Name	I/O Type	Location	Signal Category
PE0TN01	O	U13	PCI Express (cont.)
PE0TN02	O	U11	
PE0TN03	O	U10	
PE0TN04	O	U8	
PE0TN05	O	U7	
PE0TN06	O	U5	
PE0TN07	O	U4	
PE0TP00	O	V14	
PE0TP01	O	V13	
PE0TP02	O	V11	
PE0TP03	O	V10	
PE0TP04	O	V8	
PE0TP05	O	V7	
PE0TP06	O	V5	
PE0TP07	O	V4	
PE2RN00	I	M5	
PE2RN01	I	L5	
PE2RN02	I	J5	
PE2RN03	I	H5	
PE2RN04	I	F5	
PE2RN05	I	E5	
PE2RN06	I	C5	
PE2RN07	I	B5	
PE2RP00	I	M4	
PE2RP01	I	L4	
PE2RP02	I	J4	
PE2RP03	I	H4	
PE2RP04	I	F4	
PE2RP05	I	E4	
PE2RP06	I	C4	
PE2RP07	I	B4	
PE2TN00	O	M2	
PE2TN01	O	L2	
PE2TN02	O	J2	
PE2TN03	O	H2	
PE2TN04	O	F2	

Table 24 PES24T3G2 (19x19mm 324-Pin) Alphabetical Signal List (Part 2 of 4)

Signal Name	I/O Type	Location	Signal Category
PE2TN05	O	E2	PCI Express (cont.)
PE2TN06	O	C2	
PE2TN07	O	B2	
PE2TP00	O	M1	
PE2TP01	O	L1	
PE2TP02	O	J1	
PE2TP03	O	H1	
PE2TP04	O	F1	
PE2TP05	O	E1	
PE2TP06	O	C1	
PE2TP07	O	B1	
PE4RN00	I	B14	
PE4RN01	I	C14	
PE4RN02	I	E14	
PE4RN03	I	F14	
PE4RN04	I	H14	
PE4RN05	I	J14	
PE4RN06	I	L14	
PE4RN07	I	M14	
PE4RP00	I	B15	
PE4RP01	I	C15	
PE4RP02	I	E15	
PE4RP03	I	F15	
PE4RP04	I	H15	
PE4RP05	I	J15	
PE4RP06	I	L15	
PE4RP07	I	M15	
PE4TN00	O	B17	
PE4TN01	O	C17	
PE4TN02	O	E17	
PE4TN03	O	F17	
PE4TN04	O	H17	
PE4TN05	O	J17	
PE4TN06	O	L17	
PE4TN07	O	M17	
PE4TP00	O	B18	

Table 24 PES24T3G2 (19x19mm 324-Pin) Alphabetical Signal List (Part 3 of 4)

Signal Name	I/O Type	Location	Signal Category
PE4TP01	O	C18	PCI Express (cont.)
PE4TP02	O	E18	
PE4TP03	O	F18	
PE4TP04	O	H18	
PE4TP05	O	J18	
PE4TP06	O	L18	
PE4TP07	O	M18	
PEREFCLKN	I	U2	
PEREFCLKP	I	V2	
PERSTN	I	D11	System
REFRES0	I/O	V6	SerDes Reference Resistors
REFRES1	I/O	U6	
REFRES2	I/O	K1	
REFRES3	I/O	K2	
REFRES4	I/O	K18	
REFRES5	I/O	K17	
SSMBCLK	I/O	B9	SMBus
SSMBDAT	I/O	C9	
SWMODE_0	I	D10	System
SWMODE_1	I	B11	
SWMODE_2	I	C11	
V _{DD} CORE, V _{DD} I/O, V _{DD} PEA, V _{DD} PEHA, V _{DD} PETA	See Table 21 for a listing of power pins.		
V _{SS}	See Table 22 for a listing of ground pins.		

Table 24 PES24T3G2 (19x19mm 324-Pin) Alphabetical Signal List (Part 4 of 4)

Option A Package — Package Trace Length

Signal Name	Conductor Length (microns)
PE0RN00	6476.76
PE0RP00	6852.44
PE0RN01	5193.18
PE0RP01	5556.44
PE0RN02	4122.07
PE0RP02	4488.70
PE0RN03	4026.18
PE0RP03	4426.98
PE0TN00	9779.14
PE0TP00	9830.77
PE0TN01	8725.88
PE0TP01	8836.41
PE0TN02	7608.89
PE0TP02	7657.42
PE0TN03	7295.70
PE0TP03	7361.98
PE2RN00	2227.99
PE2RP00	2600.58
PE2RN01	1881.27
PE2RP01	2256.96
PE2RN02	2105.60
PE2RP02	2470.94
PE2RN03	2835.27
PE2RP03	3207.86
PE2TN00	5462.64
PE2TP00	5576.55
PE2TN01	5163.54
PE2TP01	5273.30
PE2TN02	5389.58
PE2TP02	5512.25
PE2TN03	5310.88
PE2TP03	5451.71
PE4RN00	9450.47
PE4RP00	9700.88
PE4RN01	8438.57

Table 25 Signal Trace Length (Part 1 of 2)

Signal Name	Conductor Length (microns)
PE4RP01	8818.65
PE4RN02	8521.33
PE4RP02	8890.07
PE4RN03	9130.21
PE4RP03	9403.58
PE4TN00	12116.40
PE4TP00	12168.24
PE4TN01	12011.65
PE4TP01	12035.01
PE4TN02	12731.79
PE4TP02	12864.34
PE4TN03	11571.96
PE4TP03	11712.79
PE0REFCLKN	12558.62
PE0REFCLKP	12641.05

Table 25 Signal Trace Length (Part 2 of 2)

Option A Package Pinout — Top View

	1	2	3	4	5	6	7	8	9	10	11	12	13	14	15	16	17	18	
A																			A
B																			B
C																			C
D																			D
E																			E
F																			F
G																			G
H																			H
J																			J
K																			K
L																			L
M																			M
N																			N
P																			P
R																			R
T																			T
U																			U
V																			V

	V _{DD} Core (Power)		V _{DD} PETA (Power)		V _{SS} (Ground)		Signals
	V _{DD} I/O (Power)		V _{DD} PEA (Power)		V _{DD} PEHA (Power)		No Connect

19x19mm Package Drawing — 324-Pin AL324/AR324

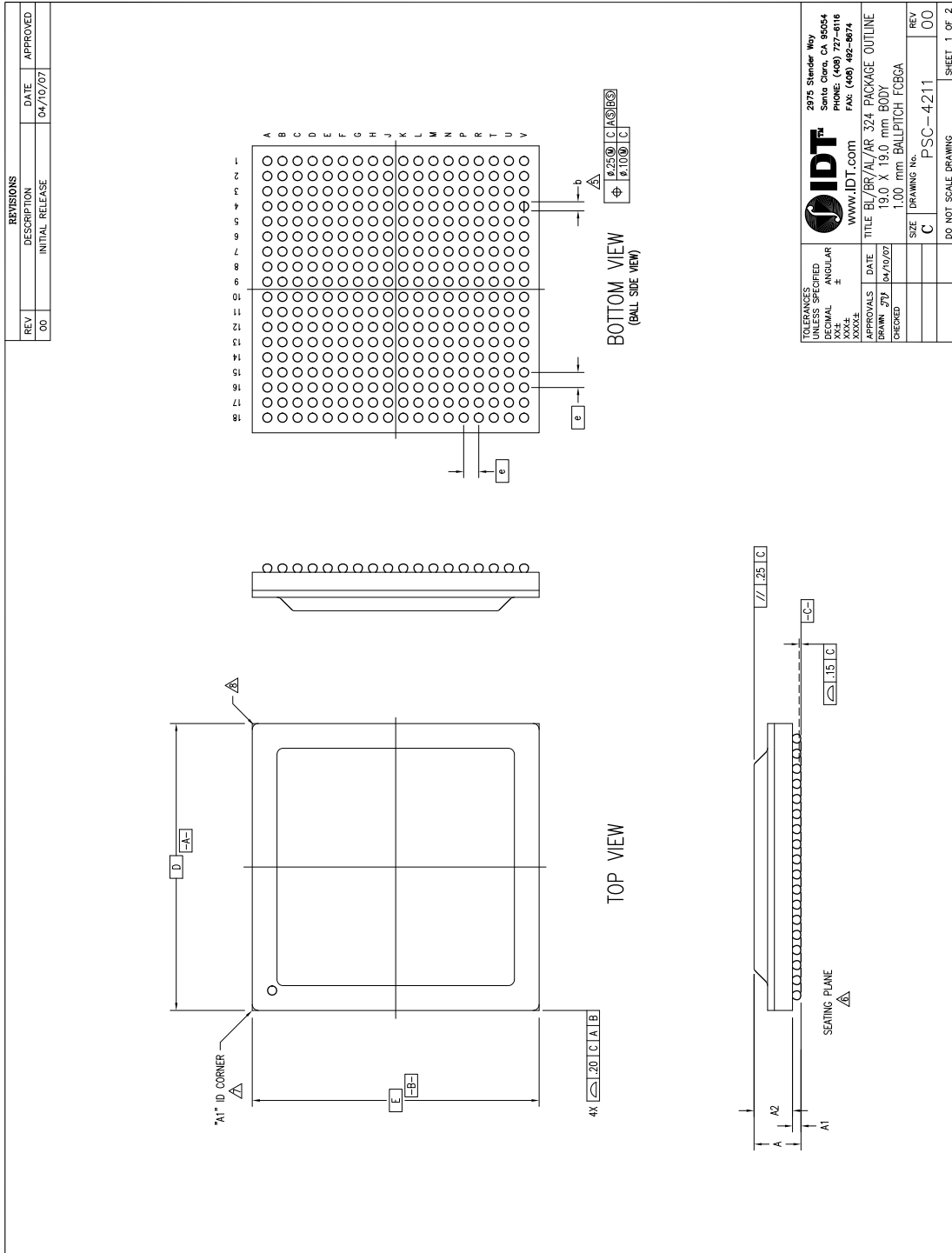

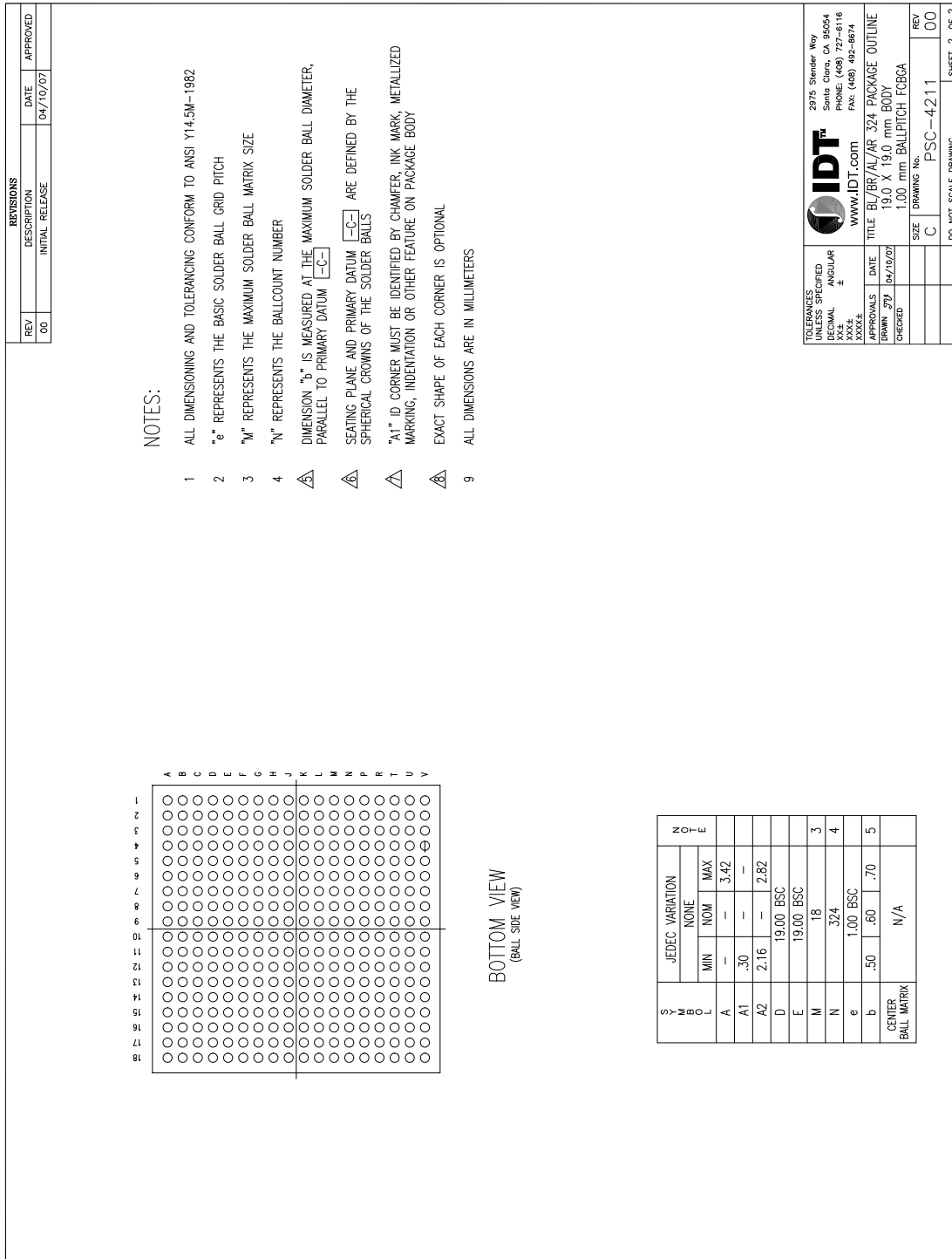

Option B Package Pinout, 27x27mm 676-BGA Signal Pinout

The following table lists the pin numbers and signal names for the PES24T3G2 device.

Pin	Function	Alt	Pin	Function	Alt	Pin	Function	Alt	Pin	Function	Alt
A1	V _{SS}		B9	MSMBDAT		C17	V _{DD} I/O		D25	V _{SS}	
A2	V _{SS}		B10	SSMBADDR_2		C18	V _{SS}		D26	NC	
A3	V _{SS}		B11	SSMBADDR_5		C19	V _{DD} I/O		E1	V _{SS}	
A4	JTAG_TDI		B12	SSMBDAT		C20	V _{SS}		E2	V _{SS}	
A5	JTAG_TMS		B13	V _{SS}		C21	V _{DD} I/O		E3	V _{SS}	
A6	MSMBADDR_1		B14	SWMODE_0		C22	GPIO_10		E4	V _{SS}	
A7	MSMBADDR_3		B15	SWMODE_2		C23	V _{DD} I/O		E5	V _{SS}	
A8	MSMBCLK		B16	V _{SS}		C24	V _{SS}		E6	V _{DD} CORE	
A9	SSMBADDR_1		B17	V _{DD} I/O		C25	V _{SS}		E7	V _{DD} CORE	
A10	SSMBADDR_3		B18	GPIO_00	1	C26	NC		E8	V _{SS}	
A11	SSMBCLK		B19	GPIO_02	1	D1	PEREFCLKP		E9	V _{DD} CORE	
A12	CCLKUS		B20	GPIO_04	1	D2	V _{SS}		E10	V _{SS}	
A13	CCLKDS		B21	GPIO_06		D3	V _{SS}		E11	V _{DD} CORE	
A14	V _{SS}		B22	MSMBSMODE		D4	V _{SS}		E12	V _{SS}	
A15	SWMODE_1		B23	REFCLKM		D5	V _{DD} CORE		E13	V _{DD} CORE	
A16	NC		B24	V _{DD} I/O		D6	V _{DD} CORE		E14	V _{SS}	
A17	PERSTN		B25	V _{SS}		D7	V _{SS}		E15	V _{DD} CORE	
A18	RSTHALT		B26	V _{SS}		D8	V _{DD} CORE		E16	V _{SS}	
A19	GPIO_01	1	C1	PEREFCLKN		D9	V _{SS}		E17	V _{DD} CORE	
A20	GPIO_03	1	C2	V _{SS}		D10	V _{DD} CORE		E18	V _{SS}	
A21	GPIO_05		C3	V _{SS}		D11	V _{SS}		E19	V _{DD} CORE	
A22	GPIO_07	1	C4	V _{DD} CORE		D12	V _{DD} CORE		E20	V _{DD} CORE	
A23	V _{SS}		C5	V _{DD} I/O		D13	V _{DD} CORE		E21	V _{DD} CORE	
A24	GPIO_09		C6	V _{SS}		D14	V _{SS}		E22	V _{SS}	
A25	V _{SS}		C7	V _{DD} I/O		D15	V _{DD} CORE		E23	V _{SS}	
A26	V _{SS}		C8	V _{SS}		D16	V _{SS}		E24	V _{SS}	
B1	V _{SS}		C9	V _{DD} I/O		D17	V _{DD} CORE		E25	V _{SS}	
B2	V _{SS}		C10	V _{SS}		D18	V _{DD} CORE		E26	V _{SS}	
B3	V _{DD} I/O		C11	V _{DD} I/O		D19	V _{DD} CORE		F1	V _{DD} CORE	
B4	JTAG_TCK		C12	V _{SS}		D20	V _{SS}		F2	V _{DD} CORE	
B5	JTAG-TDO		C13	V _{DD} I/O		D21	V _{DD} CORE		F3	V _{DD} PEA	
B6	JTAG-TRST_N		C14	V _{DD} CORE		D22	V _{DD} CORE		F4	V _{SS}	
B7	MSMBADDR_2		C15	V _{DD} I/O		D23	GPIO_08		F5	V _{SS}	
B8	MSMBADDR_4		C16	V _{DD} CORE		D24	V _{SS}		F6	V _{DD} I/O	

Table 26 PES24T3G2 (27x27mm 676-Pin) Signal Pin-Out (Part 1 of 5)

Pin	Function	Alt	Pin	Function	Alt	Pin	Function	Alt	Pin	Function	Alt
F7	V _{SS}		G18	V _{SS}		J3	V _{DD} PETA		K14	V _{SS}	
F8	V _{SS}		G19	V _{SS}		J4	PE2RN06		K15	V _{DD} CORE	
F9	V _{SS}		G20	V _{SS}		J5	PE2RP06		K16	V _{DD} CORE	
F10	V _{SS}		G21	V _{SS}		J6	V _{SS}		K17	V _{SS}	
F11	V _{SS}		G22	PE4RP00		J7	V _{DD} CORE		K18	V _{SS}	
F12	NC		G23	PE4RN00		J8	V _{DD} CORE		K19	V _{DD} CORE	
F13	V _{SS}		G24	V _{DD} PETA		J9	V _{SS}		K20	V _{DD} CORE	
F14	V _{SS}		G25	PE4TP00		J10	V _{SS}		K21	V _{SS}	
F15	V _{SS}		G26	PE4TN00		J11	V _{DD} CORE		K22	V _{DD} PEA	
F16	NC		H1	V _{SS}		J12	V _{DD} CORE		K23	V _{DD} PEA	
F17	V _{SS}		H2	V _{SS}		J13	V _{SS}		K24	V _{DD} PEA	
F18	V _{SS}		H3	V _{DD} PEHA		J14	V _{SS}		K25	V _{SS}	
F19	V _{SS}		H4	V _{DD} PEHA		J15	V _{DD} CORE		K26	REFRES4	
F20	V _{SS}		H5	V _{SS}		J16	V _{DD} CORE		L1	PE2TN05	
F21	V _{SS}		H6	V _{SS}		J17	V _{SS}		L2	PE2TP05	
F22	V _{SS}		H7	V _{DD} CORE		J18	V _{SS}		L3	V _{DD} PETA	
F23	V _{SS}		H8	V _{DD} CORE		J19	V _{DD} CORE		L4	PE2RN05	
F24	V _{DD} PEA		H9	V _{SS}		J20	V _{DD} CORE		L5	PE2RP05	
F25	V _{DD} CORE		H10	V _{SS}		J21	V _{SS}		L6	V _{SS}	
F26	V _{DD} CORE		H11	V _{DD} CORE		J22	PE4RP01		L7	V _{DD} CORE	
G1	PE2TN07		H12	V _{DD} CORE		J23	PE4RN01		L8	V _{DD} CORE	
G2	PE2TP07		H13	V _{SS}		J24	V _{DD} PETA		L9	V _{SS}	
G3	V _{DD} PETA		H14	V _{SS}		J25	PE4TP01		L10	V _{SS}	
G4	PE2RN07		H15	V _{DD} CORE		J26	PE4TN01		L11	V _{DD} CORE	
G5	PE2RP07		H16	V _{DD} CORE		K1	REFRES3		L12	V _{DD} CORE	
G6	V _{SS}		H17	V _{SS}		K2	V _{SS}		L13	V _{SS}	
G7	V _{SS}		H18	V _{SS}		K3	V _{DD} PEA		L14	V _{SS}	
G8	V _{SS}		H19	V _{DD} CORE		K4	V _{DD} PEA		L15	V _{DD} CORE	
G9	V _{SS}		H20	V _{DD} CORE		K5	V _{DD} PEA		L16	V _{DD} CORE	
G10	V _{SS}		H21	V _{SS}		K6	V _{SS}		L17	V _{SS}	
G11	V _{SS}		H22	V _{SS}		K7	V _{DD} CORE		L18	V _{SS}	
G12	V _{SS}		H23	V _{DD} PEHA		K8	V _{DD} CORE		L19	V _{DD} CORE	
G13	V _{SS}		H24	V _{DD} PEHA		K9	V _{SS}		L20	V _{DD} CORE	
G14	V _{SS}		H25	V _{SS}		K10	V _{SS}		L21	V _{SS}	
G15	V _{SS}		H26	V _{SS}		K11	V _{DD} CORE		L22	PE4RP02	
G16	V _{SS}		J1	PE2TN06		K12	V _{DD} CORE		L23	PE4RN02	
G17	V _{SS}		J2	PE2TP06		K13	V _{SS}		L24	V _{DD} PETA	

Table 26 PES24T3G2 (27x27mm 676-Pin) Signal Pin-Out (Part 2 of 5)

Pin	Function	Alt	Pin	Function	Alt	Pin	Function	Alt	Pin	Function	Alt
L25	PE4TP02		N10	V _{SS}		P21	V _{SS}		T6	NC	
L26	PE4TN02		N11	V _{DD} CORE		P22	V _{SS}		T7	V _{DD} CORE	
M1	V _{DD} CORE		N12	V _{DD} CORE		P23	V _{DD} PEHA		T8	V _{DD} CORE	
M2	V _{SS}		N13	V _{SS}		P24	V _{DD} PEHA		T9	V _{SS}	
M3	V _{DD} PEHA		N14	V _{SS}		P25	V _{SS}		T10	V _{SS}	
M4	V _{DD} PEHA		N15	V _{DD} CORE		P26	V _{DD} CORE		T11	V _{DD} CORE	
M5	V _{SS}		N16	V _{DD} CORE		R1	PE2TN03		T12	V _{DD} CORE	
M6	NC		N17	V _{SS}		R2	PE2TP03		T13	V _{SS}	
M7	V _{DD} CORE		N18	V _{SS}		R3	V _{DD} PETA		T14	V _{SS}	
M8	V _{DD} CORE		N19	V _{DD} CORE		R4	PE2RN03		T15	V _{DD} CORE	
M9	V _{SS}		N20	V _{DD} CORE		R5	PE2RP03		T16	V _{DD} CORE	
M10	V _{SS}		N21	V _{SS}		R6	V _{SS}		T17	V _{SS}	
M11	V _{DD} CORE		N22	PE4RP03		R7	V _{DD} CORE		T18	V _{SS}	
M12	V _{DD} CORE		N23	PE4RN03		R8	V _{DD} CORE		T19	V _{DD} CORE	
M13	V _{SS}		N24	V _{DD} PETA		R9	V _{SS}		T20	V _{DD} CORE	
M14	V _{SS}		N25	PE4TP03		R10	V _{SS}		T21	NC	
M15	V _{DD} CORE		N26	PE4TN03		R11	V _{DD} CORE		T22	V _{SS}	
M16	V _{DD} CORE		P1	V _{DD} CORE		R12	V _{DD} CORE		T23	V _{DD} PEA	
M17	V _{SS}		P2	V _{SS}		R13	V _{SS}		T24	V _{DD} PEA	
M18	V _{SS}		P3	V _{DD} PEHA		R14	V _{SS}		T25	V _{SS}	
M19	V _{DD} CORE		P4	V _{DD} PEHA		R15	V _{DD} CORE		T26	V _{DD} CORE	
M20	V _{DD} CORE		P5	V _{SS}		R16	V _{DD} CORE		U1	PE2TN02	
M21	NC		P6	V _{SS}		R17	V _{SS}		U2	PE2TP02	
M22	V _{SS}		P7	V _{DD} CORE		R18	V _{SS}		U3	V _{DD} PETA	
M23	V _{DD} PEHA		P8	V _{DD} CORE		R19	V _{DD} CORE		U4	PE2RN02	
M24	V _{DD} PEHA		P9	V _{SS}		R20	V _{DD} CORE		U5	PE2RP02	
M25	V _{SS}		P10	V _{SS}		R21	V _{SS}		U6	V _{SS}	
M26	V _{DD} CORE		P11	V _{DD} CORE		R22	PE4RP04		U7	V _{DD} CORE	
N1	PE2TN04		P12	V _{DD} CORE		R23	PE4RN04		U8	V _{DD} CORE	
N2	PE2TP04		P13	V _{SS}		R24	V _{DD} PETA		U9	V _{SS}	
N3	V _{DD} PETA		P14	V _{SS}		R25	PE4TP04		U10	V _{SS}	
N4	PE2RN04		P15	V _{DD} CORE		R26	PE4TN04		U11	V _{DD} CORE	
N5	PE2RP04		P16	V _{DD} CORE		T1	V _{DD} CORE		U12	V _{DD} CORE	
N6	V _{SS}		P17	V _{SS}		T2	V _{SS}		U13	V _{SS}	
N7	V _{DD} CORE		P18	V _{SS}		T3	V _{DD} PEA		U14	V _{SS}	
N8	V _{DD} CORE		P19	V _{DD} CORE		T4	V _{DD} PEA		U15	V _{DD} CORE	
N9	V _{SS}		P20	V _{DD} CORE		T5	V _{SS}		U16	V _{DD} CORE	

Table 26 PES24T3G2 (27x27mm 676-Pin) Signal Pin-Out (Part 3 of 5)

Pin	Function	Alt	Pin	Function	Alt	Pin	Function	Alt	Pin	Function	Alt
U17	V _{SS}		W2	PE2TP01		Y13	V _{SS}		AA24	V _{DD} PETA	
U18	V _{SS}		W3	V _{DD} PETA		Y14	V _{SS}		AA25	PE4TP07	
U19	V _{DD} CORE		W4	PE2RN01		Y15	V _{DD} CORE		AA26	PE4TN07	
U20	V _{DD} CORE		W5	PE2RP01		Y16	V _{DD} CORE		AB1	V _{SS}	
U21	V _{SS}		W6	V _{SS}		Y17	V _{SS}		AB2	V _{SS}	
U22	PE4RP05		W7	V _{DD} CORE		Y18	V _{SS}		AB3	V _{DD} CORE	
U23	PE4RN05		W8	V _{DD} CORE		Y19	V _{DD} CORE		AB4	V _{DD} CORE	
U24	V _{DD} PETA		W9	V _{SS}		Y20	V _{DD} CORE		AB5	V _{DD} CORE	
U25	PE4TP05		W10	V _{SS}		Y21	V _{SS}		AB6	V _{SS}	
U26	PE4TN05		W11	V _{DD} CORE		Y22	V _{SS}		AB7	PE0RP07	
V1	V _{DD} CORE		W12	V _{DD} CORE		Y23	V _{DD} PEHA		AB8	V _{SS}	
V2	V _{SS}		W13	V _{SS}		Y24	V _{DD} PEHA		AB9	PE0RP06	
V3	V _{DD} PEA		W14	V _{SS}		Y25	V _{SS}		AB10	V _{DD} PEA	
V4	V _{DD} PEA		W15	V _{DD} CORE		Y26	REFRES5		AB11	PE0RP05	
V5	V _{DD} PEA		W16	V _{DD} CORE		AA1	PE2TN00		AB12	V _{SS}	
V6	V _{SS}		W17	V _{SS}		AA2	PE2TP00		AB13	PE0RP04	
V7	V _{DD} CORE		W18	V _{SS}		AA3	V _{DD} PETA		AB14	V _{DD} PEA	
V8	V _{DD} CORE		W19	V _{DD} CORE		AA4	PE2RN00		AB15	PE0RP03	
V9	V _{SS}		W20	V _{DD} CORE		AA5	PE2RP00		AB16	V _{SS}	
V10	V _{SS}		W21	V _{SS}		AA6	V _{SS}		AB17	PE0RP02	
V11	V _{DD} CORE		W22	PE4RP06		AA7	V _{SS}		AB18	V _{DD} PEA	
V12	V _{DD} CORE		W23	PE4RN06		AA8	V _{SS}		AB19	PE0RP01	
V13	V _{SS}		W24	V _{DD} PETA		AA9	V _{SS}		AB20	V _{SS}	
V14	V _{SS}		W25	PE4TP06		AA10	V _{SS}		AB21	PE0RP00	
V15	V _{DD} CORE		W26	PE4TN06		AA11	V _{SS}		AB22	V _{SS}	
V16	V _{DD} CORE		Y1	REFRES2		AA12	NC		AB23	V _{DD} CORE	
V17	V _{SS}		Y2	V _{SS}		AA13	V _{SS}		AB24	V _{DD} CORE	
V18	V _{SS}		Y3	V _{DD} PEHA		AA14	V _{SS}		AB25	V _{SS}	
V19	V _{DD} CORE		Y4	V _{DD} PEHA		AA15	V _{SS}		AB26	V _{SS}	
V20	V _{DD} CORE		Y5	V _{SS}		AA16	NC		AC1	V _{SS}	
V21	V _{SS}		Y6	V _{SS}		AA17	V _{SS}		AC2	V _{SS}	
V22	V _{DD} PEA		Y7	V _{DD} CORE		AA18	V _{SS}		AC3	V _{DD} CORE	
V23	V _{DD} PEA		Y8	V _{DD} CORE		AA19	V _{SS}		AC4	V _{DD} CORE	
V24	V _{DD} PEA		Y9	V _{SS}		AA20	V _{SS}		AC5	V _{DD} CORE	
V25	V _{SS}		Y10	V _{SS}		AA21	V _{SS}		AC6	V _{DD} PEHA	
V26	V _{DD} CORE		Y11	V _{DD} CORE		AA22	PE4RP07		AC7	PE0RN07	
W1	PE2TN01		Y12	V _{DD} CORE		AA23	PE4RN07		AC8	V _{DD} PEA	

Table 26 PES24T3G2 (27x27mm 676-Pin) Signal Pin-Out (Part 4 of 5)

Pin	Function	Alt	Pin	Function	Alt	Pin	Function	Alt	Pin	Function	Alt
AC9	PE0RN06		AD7	V _{SS}		AE5	V _{SS}		AF3	V _{DD} CORE	
AC10	V _{DD} PEA		AD8	V _{DD} PETA		AE6	V _{SS}		AF4	V _{DD} CORE	
AC11	PE0RN05		AD9	V _{SS}		AE7	PE0TP07		AF5	V _{DD} CORE	
AC12	V _{DD} PEHA		AD10	V _{DD} PETA		AE8	V _{SS}		AF6	V _{SS}	
AC13	PE0RN04		AD11	V _{DD} PETA		AE9	PE0TP06		AF7	PE0TN07	
AC14	V _{DD} PEHA		AD12	V _{DD} PEHA		AE10	V _{SS}		AF8	REFRES1	
AC15	PE0RN03		AD13	V _{DD} PETA		AE11	PE0TP05		AF9	PE0TN06	
AC16	V _{DD} PEA		AD14	V _{DD} PEHA		AE12	V _{SS}		AF10	V _{DD} CORE	
AC17	PE0RN02		AD15	V _{DD} PETA		AE13	PE0TP04		AF11	PE0TN05	
AC18	V _{DD} PEA		AD16	V _{DD} PEA		AE14	V _{SS}		AF12	V _{DD} CORE	
AC19	PE0RN01		AD17	V _{SS}		AE15	PE0TP03		AF13	PE0TN04	
AC20	V _{DD} PEHA		AD18	V _{DD} PETA		AE16	V _{SS}		AF14	V _{DD} CORE	
AC21	PE0RN00		AD19	V _{DD} PETA		AE17	PE0TP02		AF15	PE0TN03	
AC22	V _{SS}		AD20	V _{DD} PEHA		AE18	V _{SS}		AF16	V _{DD} CORE	
AC23	V _{DD} CORE		AD21	V _{DD} PETA		AE19	PE0TP01		AF17	PE0TN02	
AC24	V _{DD} CORE		AD22	V _{SS}		AE20	V _{SS}		AF18	REFRES0	
AC25	V _{SS}		AD23	V _{DD} CORE		AE21	PE0TP00		AF19	PE0TN01	
AC26	V _{SS}		AD24	V _{DD} CORE		AE22	V _{SS}		AF20	V _{SS}	
AD1	V _{SS}		AD25	V _{SS}		AE23	V _{DD} CORE		AF21	PE0TN00	
AD2	V _{SS}		AD26	V _{SS}		AE24	V _{DD} CORE		AF22	V _{SS}	
AD3	V _{DD} CORE		AE1	V _{SS}		AE25	V _{SS}		AF23	V _{DD} CORE	
AD4	V _{DD} CORE		AE2	V _{SS}		AE26	V _{SS}		AF24	V _{DD} CORE	
AD5	V _{DD} CORE		AE3	V _{DD} CORE		AF1	V _{SS}		AF25	V _{SS}	
AD6	V _{DD} PEHA		AE4	V _{DD} CORE		AF2	V _{SS}		AF26	V _{SS}	

Table 26 PES24T3G2 (27x27mm 676-Pin) Signal Pin-Out (Part 5 of 5)

Option B Package Core Power Pins (27x27mm 676-Pin Package)

V _{DD} Core	V _{DD} Core	V _{DD} Core	V _{DD} Core	V _{DD} Core	V _{DD} Core
C4	H7	L16	P20	V7	AB24
C14	H8	L19	P26	V8	AC3
C16	H11	L20	R7	V11	AC4
D5	H12	M1	R8	V12	AC5
D6	H15	M7	R11	V15	AC23
D8	H16	M8	R12	V16	AC24
D10	H19	M11	R15	V19	AD3
D12	H20	M12	R16	V20	AD4
D13	J7	M15	R19	V26	AD5
D15	J8	M16	R20	W7	AD23
D17	J11	M19	T1	W8	AD24
D18	J12	M20	T7	W11	AE3
D19	J15	M26	T8	W12	AE4
D21	J16	N7	T11	W15	AE23
D22	J19	N8	T12	W16	AE24
E6	J20	N11	T15	W19	AF3
E7	K7	N12	T16	W20	AF4
E9	K8	N15	T19	Y7	AF5
E11	K11	N16	T20	Y8	AF10
E13	K12	N19	T26	Y11	AF12
E15	K15	N20	U7	Y12	AF14
E17	K16	P1	U8	Y15	AF16
E19	K19	P7	U11	Y16	AF23
E20	K20	P8	U12	Y19	AF24
E21	L7	P11	U15	Y20	
F1	L8	P12	U16	AB3	
F2	L11	P15	U19	AB4	
F25	L12	P16	U20	AB5	
F26	L15	P19	V1	AB23	

Table 27 PES24T3G2 (27x27mm 676-Pin) Core Power Pins

Option B Package I/O, PCIe, and Transmitter Power Pins (27x27mm 676-Pin)

V _{DD} I/O	V _{DD} PEA	V _{DD} PEHA	V _{DD} PETA
B3	F3	H3	G3
B17	F24	H4	G24
B24	K3	H23	J3
C5	K4	H24	J24
C7	K5	M3	L3
C9	K22	M4	L24
C11	K23	M23	N3
C13	K24	M24	N24
C15	T3	P3	R3
C17	T4	P4	R24
C19	T23	P23	U3
C21	T24	P24	U24
C23	V3	Y3	W3
F6	V4	Y4	W24
	V5	Y23	AA3
	V22	Y24	AA24
	V23	AC6	AD8
	V24	AC12	AD10
	AB10	AC14	AD11
	AB14	AC20	AD13
	AB18	AD6	AD15
	AC8	AD12	AD18
	AC10	AD14	AD19
	AC16	AD20	AD21
	AC18		
	AD16		

Table 28 PES24T3G2 (27x27mm 676-Pin) I/O, PCIe, Transmitter Power Pins

Option B Package Ground Pins (27x27mm 676-Pin)

V _{SS}	V _{SS}	V _{SS}	V _{SS}	V _{SS}	V _{SS}	V _{SS}	V _{SS}
A1	E1	G7	J17	N13	T25	Y17	AD1
A2	E2	G8	J18	N14	U6	Y18	AD2
A3	E3	G9	J21	N17	U9	Y21	AD7
A14	E4	G10	K2	N18	U10	Y22	AD9
A23	E5	G11	K6	N21	U13	Y25	AD17
A25	E8	G12	K9	P2	U14	AA6	AD22
A26	E10	G13	K10	P5	U17	AA7	AD25
B1	E12	G14	K13	P6	U18	AA8	AD26
B2	E14	G15	K14	P9	U21	AA9	AE1
B13	E16	G16	K17	P10	V2	AA10	AE2
B16	E18	G17	K18	P13	V6	AA11	AE5
B25	E22	G18	K21	P14	V9	AA13	AE6
B26	E23	G19	K25	P17	V10	AA14	AE8
C2	E24	G20	L6	P18	V13	AA15	AE10
C3	E25	G21	L9	P21	V14	AA17	AE12
C6	E26	H1	L10	P22	V17	AA18	AE14
C8	F4	H2	L13	P25	V18	AA19	AE16
C10	F5	H5	L14	R6	V21	AA20	AE18
C12	F7	H6	L17	R9	V25	AA21	AE20
C18	F8	H9	L18	R10	W6	AB1	AE22
C20	F9	H10	L21	R13	W9	AB2	AE25
C24	F10	H13	M2	R14	W10	AB6	AE26
C25	F11	H14	M5	R17	W13	AB8	AF1
D2	F13	H17	M9	R18	W14	AB12	AF2
D3	F14	H18	M10	R21	W17	AB16	AF6
D4	F15	H21	M13	T2	W18	AB20	AF20
D7	F17	H22	M14	T5	W21	AB22	AF22
D9	F18	H25	M17	T9	Y2	AB25	AF25
D11	F19	H26	M18	T10	Y5	AB26	AF26
D14	F20	J6	M22	T13	Y6	AC1	
D16	F21	J9	M25	T14	Y9	AC2	
D20	F22	J10	N6	T17	Y10	AC22	
D24	F23	J13	N9	T18	Y13	AC25	
D25	G6	J14	N10	T22	Y14	AC26	

Table 29 PES24T3G2 (27x27mm 676-Pin) Ground Pins

Option B Package Alternate Signal Functions (27x27mm 676-Pin)

Pin	GPIO	Alternate
B18	GPIO[0]	P2RSTN
A19	GPIO[1]	P4RSTN
B19	GPIO[2]	IOEXPINTN0
A20	GPIO[3]	IOEXPINTN1
B20	GPIO[4]	IOEXPINTN2
A22	GPIO[7]	GPEN

Table 30 PES24T3G2 (27x27mm 676-Pin) Alternate Signal Functions

Option B Package No Connect Pins (27x27mm 676-Pin)

NC Pins
A16
C26
D26
F12
F16
M6
M21
T6
T21
AA12
AA16

Table 31 PES24T3G2 (27x27mm 676-Pin) No Connect Pins

Option B Package Signals Listed Alphabetically (27x27mm 676-Pin)

Signal Name	I/O Type	Location	Signal Category
CCLKDS	I	A13	System
CCLKUS	I	A12	
GPIO_00	I/O	B18	General Purpose Input/Output
GPIO_01	I/O	A19	
GPIO_02	I/O	B19	
GPIO_03	I/O	A20	
GPIO_04	I/O	B20	
GPIO_05	I/O	A21	
GPIO_06	I/O	B21	
GPIO_07	I/O	A22	
GPIO_08	I/O	D23	
GPIO_09	I/O	A24	
GPIO_10	I/O	C22	
JTAG_TCK	I	B4	JTAG
JTAG_TDI	I	A4	
JTAG_TDO	O	B5	
JTAG_TMS	I	A5	
JTAG_TRST_N	I	B6	
MSMBADDR_1	I	A6	SMBus
MSMBADDR_2	I	B7	
MSMBADDR_3	I	A7	
MSMBADDR_4	I	B8	
MSMBCLK	I/O	A8	
MSMBDAT	I/O	B9	
MSMBSMODE	I	B22	System
NO CONNECT	See Table 31 for a list of No Connect pins.		

Table 32 PES24T3G2 (27x27mm 676-Pin) Alphabetical Signal List (Part 1 of 5)

Signal Name	I/O Type	Location	Signal Category
PE0RN00	I	AC21	PCI Express
PE0RN01	I	AC19	
PE0RN02	I	AC17	
PE0RN03	I	AC15	
PE0RN04	I	AC13	
PE0RN05	I	AC11	
PE0RN06	I	AC9	
PE0RN07	I	AC7	
PE0RP00	I	AB21	
PE0RP01	I	AB19	
PE0RP02	I	AB17	
PE0RP03	I	AB15	
PE0RP04	I	AB13	
PE0RP05	I	AB11	
PE0RP06	I	AB9	
PE0RP07	I	AB7	
PE0TN00	O	AF21	
PE0TN01	O	AF19	
PE0TN02	O	AF17	
PE0TN03	O	AF15	
PE0TN04	O	AF13	
PE0TN05	O	AF11	
PE0TN06	O	AF9	
PE0TN07	O	AF7	
PE0TP00	O	AE21	
PE0TP01	O	AE19	
PE0TP02	O	AE17	
PE0TP03	O	AE15	
PE0TP04	O	AE13	
PE0TP05	O	AE11	
PE0TP06	O	AE9	
PE0TP07	O	AE7	
PE2RN00	I	AA4	
PE2RN01	I	W4	
PE2RN02	I	U4	
PE2RN03	I	R4	

Table 32 PES24T3G2 (27x27mm 676-Pin) Alphabetical Signal List (Part 2 of 5)

Signal Name	I/O Type	Location	Signal Category
PE2RN04	I	N4	PCI Express (cont.)
PE2RN05	I	L4	
PE2RN06	I	J4	
PE2RN07	I	G4	
PE2RP00	I	AA5	
PE2RP01	I	W5	
PE2RP02	I	U5	
PE2RP03	I	R5	
PE2RP04	I	N5	
PE2RP05	I	L5	
PE2RP06	I	J5	
PE2RP07	I	G5	
PE2TN00	O	AA1	
PE2TN01	O	W1	
PE2TN02	O	U1	
PE2TN03	O	R1	
PE2TN04	O	N1	
PE2TN05	O	L1	
PE2TN06	O	J1	
PE2TN07	O	G1	
PE2TP00	O	AA2	
PE2TP01	O	W2	
PE2TP02	O	U2	
PE2TP03	O	R2	
PE2TP04	O	N2	
PE2TP05	O	L2	
PE2TP06	O	J2	
PE2TP07	O	G2	
PE4RN00	I	G23	
PE4RN01	I	J23	
PE4RN02	I	L23	
PE4RN03	I	N23	
PE4RN04	I	R23	
PE4RN05	I	U23	
PE4RN06	I	W23	
PE4RN07	I	AA23	

Table 32 PES24T3G2 (27x27mm 676-Pin) Alphabetical Signal List (Part 3 of 5)

Signal Name	I/O Type	Location	Signal Category
PE4RP00	I	G22	PCI Express (cont.)
PE4RP01	I	J22	
PE4RP02	I	L22	
PE4RP03	I	N22	
PE4RP04	I	R22	
PE4RP05	I	U22	
PE4RP06	I	W22	
PE4RP07	I	AA22	
PE4TN00	O	G26	
PE4TN01	O	J26	
PE4TN02	O	L26	
PE4TN03	O	N26	
PE4TN04	O	R26	
PE4TN05	O	U26	
PE4TN06	O	W26	
PE4TN07	O	AA26	
PE4TP00	O	G25	
PE4TP01	O	J25	
PE4TP02	O	L25	
PE4TP03	O	N25	
PE4TP04	O	R25	
PE4TP05	O	U25	
PE4TP06	O	W25	
PE4TP07	O	AA25	
PEREFCLKN	I	C1	
PEREFCLKP	I	D1	
PERSTN	I	A17	System
REFCLKM	I	B23	PCI Express
REFRES0	I/O	AF18	SerDes Reference Resistors
REFRES1	I/O	AF8	
REFRES2	I/O	Y1	
REFRES3	I/O	K1	
REFRES4	I/O	K26	
REFRES5	I/O	Y26	
RSTHALT	I	A18	System

Table 32 PES24T3G2 (27x27mm 676-Pin) Alphabetical Signal List (Part 4 of 5)

Signal Name	I/O Type	Location	Signal Category
SSMBADDR_1	I	A9	SMBus
SSMBADDR_2	I	B10	
SSMBADDR_3	I	A10	
SSMBADDR_5	I	B11	
SSMBCLK	I/O	A11	
SSMBDAT	I/O	B12	
SWMODE_0	I	B14	System
SWMODE_1	I	A15	
SWMODE_2	I	B15	
V _{DD} CORE, V _{DD} I/O, V _{DD} PEA, V _{DD} PEHA, V _{DD} PETA	See Tables 27 and 28 for a listing of power pins.		
V _{SS}	See Table 29 for a listing of ground pins.		

Table 32 PES24T3G2 (27x27mm 676-Pin) Alphabetical Signal List (Part 5 of 5)

27x27mm Package Drawing — 676-Pin BL676/BR676

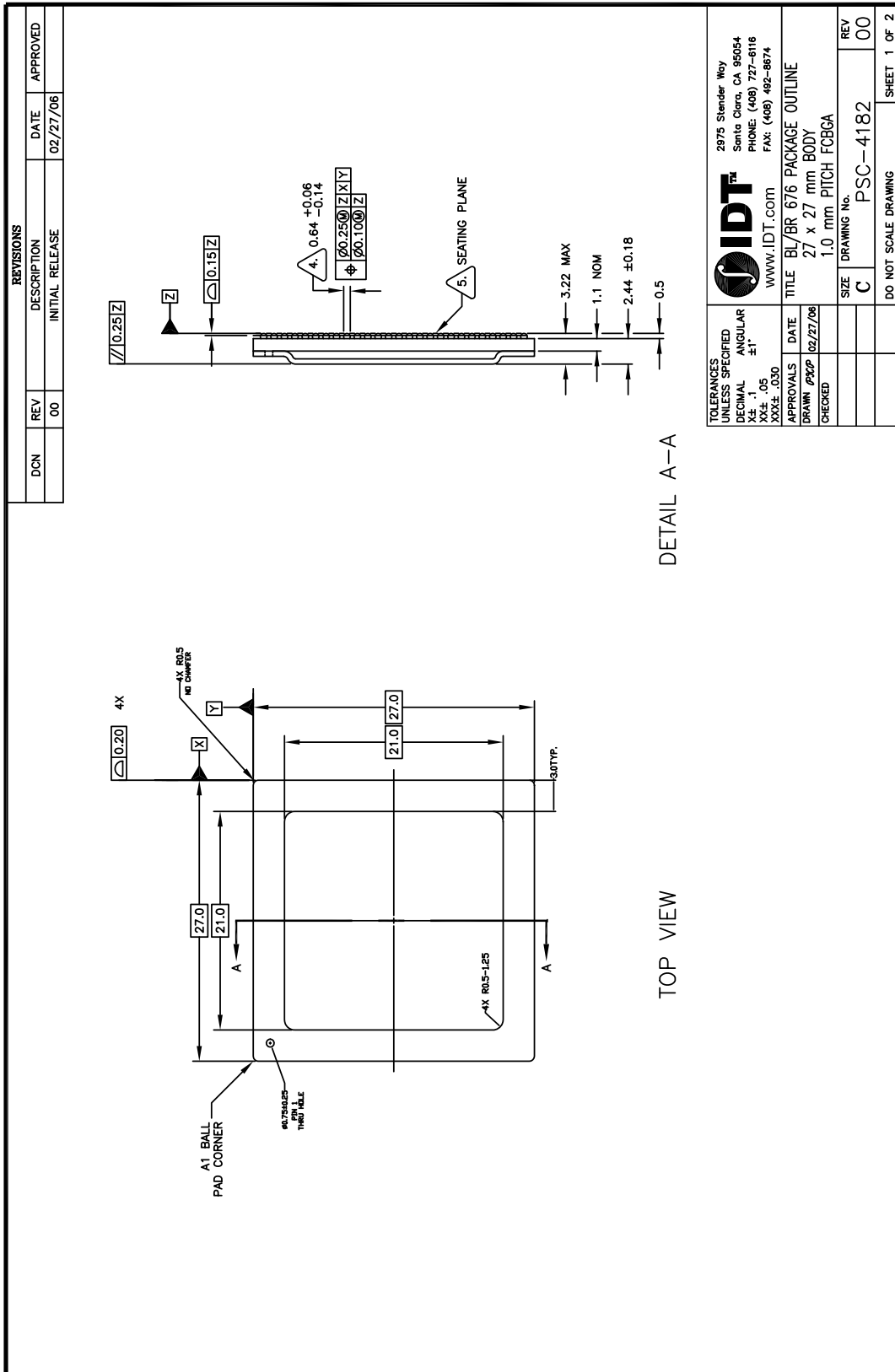

		2975 Stender Way Santa Clara, CA 95054 PHONE: (408) 727-8116 FAX: (408) 492-8874	
TOLERANCES UNLESS SPECIFIED DECIMAL ANGULAR XX.X .05 XXX.X .030		www.IDT.com	
APPROVALS DRAWN: PPKP CHECKED:		TITLE: BL/BR 676 PACKAGE OUTLINE 27 x 27 mm BODY 1.0 mm PITCH FCBGA	
DATE: 02/27/06		SIZE: C DRAWING No: PSC-4182	
REV: 00		SHEET 1 OF 2	

DETAIL A-A

TOP VIEW

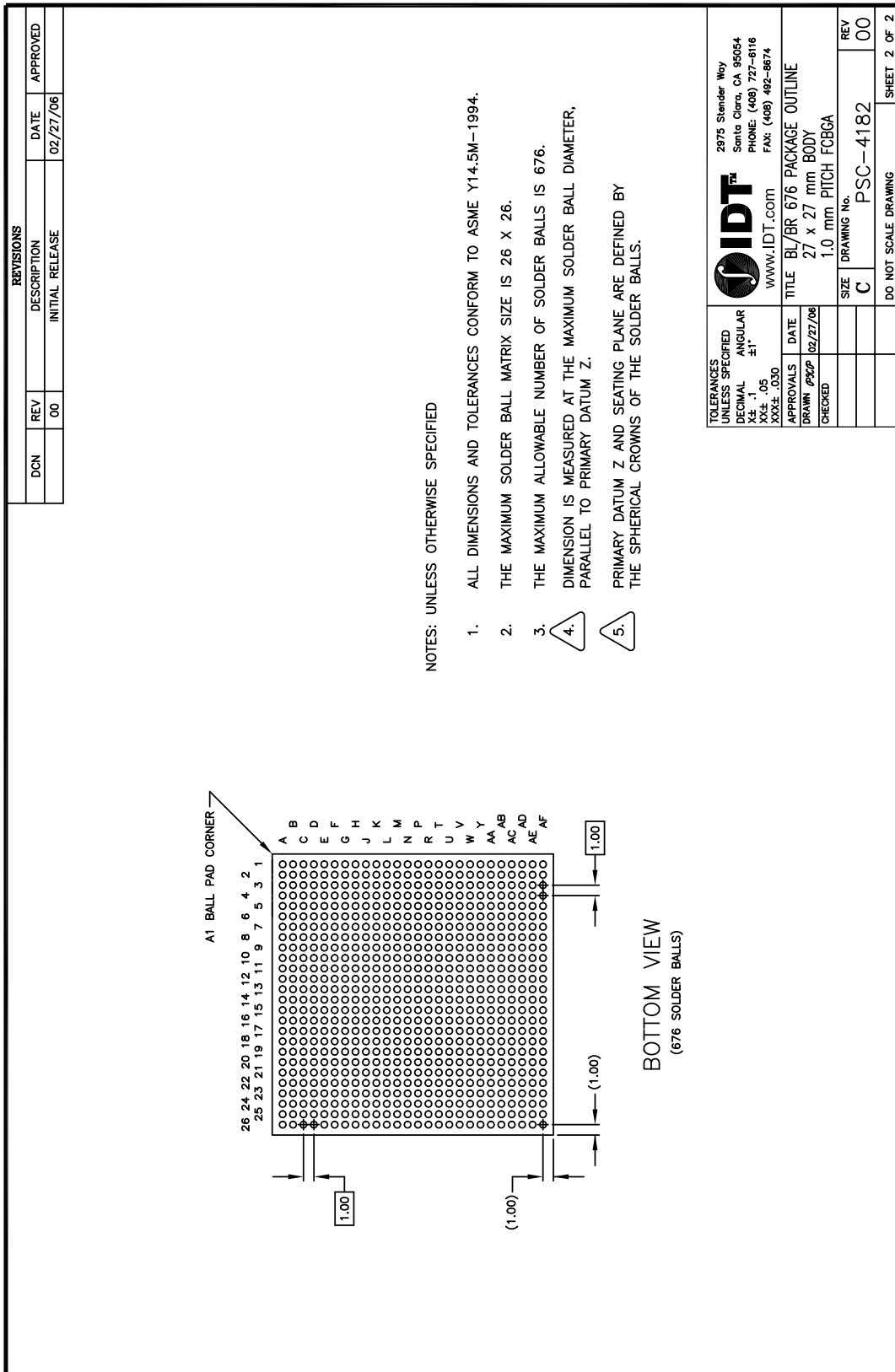

Revision History

January 15, 2009: Publication of final data sheet.

February 11, 2009: Revised AC Timing Characteristics table and DC Electrical Characteristics table to correct typos.

March 6, 2009: Added industrial temperature.

April 7, 2009: In Valid Combinations, changed ZB to ZC silicon for commercial temperature.

February 2, 2010: Added new section Absolute Maximum Voltage Rating with table.

September 13, 2010: In Table 8, changed Buffer type for PCI Express from CML to PCIe differential and changed reference clocks to HCSL.

September 29, 2010: Corrected typo in Ordering Code for 324-ball Green FCBGA package, Industrial Temperature.

January 20, 2011: Added new [Table 25](#), Package Trace Length for 19x19mm FCBGA package.

March 30, 2011: In [Table 13](#), added VddPETA to footnote #1.

September 4, 2012: Removed references to extra ports in [Table 25](#).

December 16, 2013: Changed the revision identifier to ZC from ZF in [Ordering Information](#).

Ordering Information

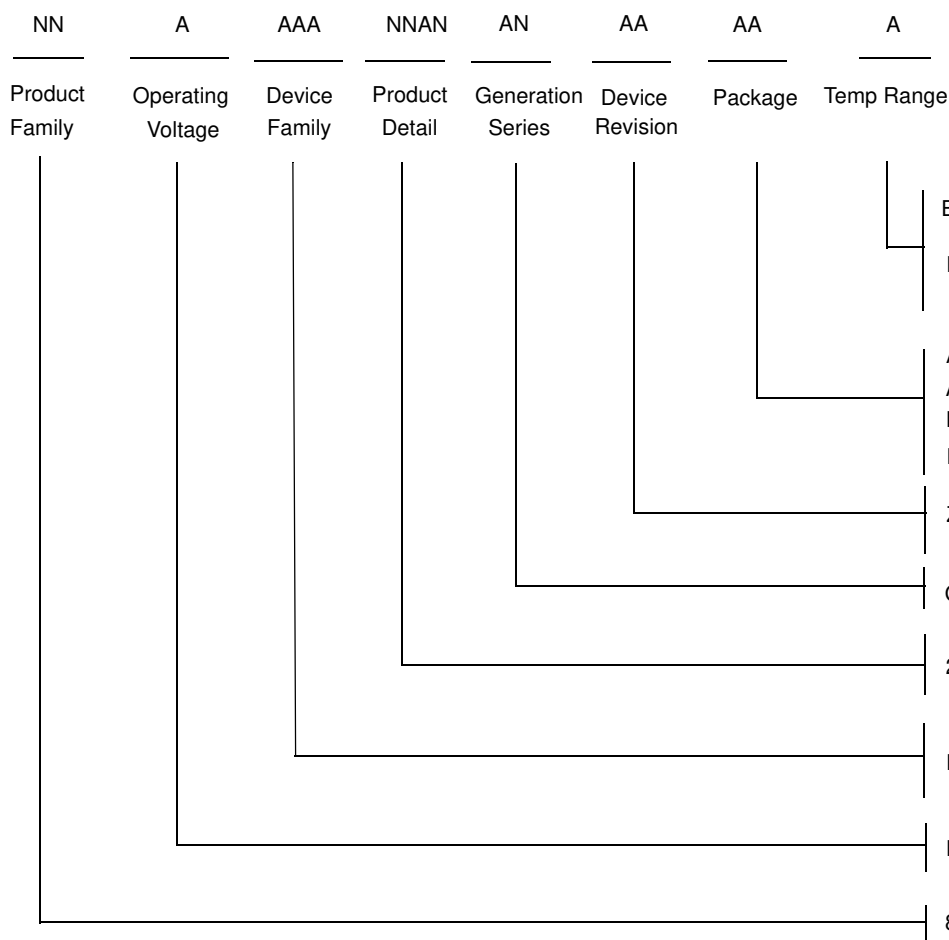

Legend
 A = Alpha Character
 N = Numeric Character

Blank Commercial Temperature (0°C to +70°C Ambient)
 I Industrial Temperature (-40° C to +85° C Ambient)
 AL 324-ball FCBGA
 ALG 324-ball FCBGA, Green
 BL 676-ball FCBGA
 BLG 676-ball FCBGA, Green
 ZC ZC revision
 G2 PCIe Gen 2
 24T3 24-lane, 3-port
 PES PCI Express Switch
 H 1.0V +/- 0.1V Core Voltage
 89 Serial Switching Product

Valid Combinations

Option A (19x19mm)

- 89HPES24T3G2ZCAL 324-ball FCBGA package, Commercial Temperature
- 89HPES24T3G2ZCALG 324-ball Green FCBGA package, Commercial Temperature
- 89HPES24T3G2ZCALI 324-ball FCBGA package, Industrial Temperature
- 89HPES24T3G2ZCALGI 324-ball Green FCBGA package, Industrial Temperature

Option B (27x27mm)

- 89HPES24T3G2ZCBL 676-ball FCBGA package, Commercial Temperature
- 89HPES24T3G2ZCBLG 676-ball Green FCBGA package, Commercial Temperature
- 89HPES24T3G2ZCBLI 676-ball FCBGA package, Industrial Temperature
- 89HPES24T3G2ZCBLGI 676-ball Green FCBGA package, Industrial Temperature

IMPORTANT NOTICE AND DISCLAIMER

RENESAS ELECTRONICS CORPORATION AND ITS SUBSIDIARIES (“RENESAS”) PROVIDES TECHNICAL SPECIFICATIONS AND RELIABILITY DATA (INCLUDING DATASHEETS), DESIGN RESOURCES (INCLUDING REFERENCE DESIGNS), APPLICATION OR OTHER DESIGN ADVICE, WEB TOOLS, SAFETY INFORMATION, AND OTHER RESOURCES “AS IS” AND WITH ALL FAULTS, AND DISCLAIMS ALL WARRANTIES, EXPRESS OR IMPLIED, INCLUDING, WITHOUT LIMITATION, ANY IMPLIED WARRANTIES OF MERCHANTABILITY, FITNESS FOR A PARTICULAR PURPOSE, OR NON-INFRINGEMENT OF THIRD PARTY INTELLECTUAL PROPERTY RIGHTS.

These resources are intended for developers skilled in the art designing with Renesas products. You are solely responsible for (1) selecting the appropriate products for your application, (2) designing, validating, and testing your application, and (3) ensuring your application meets applicable standards, and any other safety, security, or other requirements. These resources are subject to change without notice. Renesas grants you permission to use these resources only for development of an application that uses Renesas products. Other reproduction or use of these resources is strictly prohibited. No license is granted to any other Renesas intellectual property or to any third party intellectual property. Renesas disclaims responsibility for, and you will fully indemnify Renesas and its representatives against, any claims, damages, costs, losses, or liabilities arising out of your use of these resources. Renesas' products are provided only subject to Renesas' Terms and Conditions of Sale or other applicable terms agreed to in writing. No use of any Renesas resources expands or otherwise alters any applicable warranties or warranty disclaimers for these products.

(Disclaimer Rev.1.0 Mar 2020)

Corporate Headquarters

TOYOSU FORESIA, 3-2-24 Toyosu,
Koto-ku, Tokyo 135-0061, Japan
www.renesas.com

Contact Information

For further information on a product, technology, the most up-to-date version of a document, or your nearest sales office, please visit:
www.renesas.com/contact/

Trademarks

Renesas and the Renesas logo are trademarks of Renesas Electronics Corporation. All trademarks and registered trademarks are the property of their respective owners.