



**MULTI-INNO TECHNOLOGY CO., LTD.**

[www.multi-inno.com](http://www.multi-inno.com)

## LCD MODULE SPECIFICATION

**Model : MI0283QT-11**

**For Customer's Acceptance:**

Customer	
Approved	
Comment	

Revision	1.2
Engineering	
Date	2012-11-26
Our Reference	





# CONTENTS

- GENERAL INFORMATION
- EXTERNAL DIMENSIONS
- ABSOLUTE MAXIMUM RATINGS
- ELECTRICAL CHARACTERISTICS
- BACKLIGHT CHARACTERISTICS
- ELECTRO-OPTICAL CHARACTERISTICS
- INTERFACE DESCRIPTION
- APPLICATION NOTES
- INITIAL CODE
- RELIABILITY TEST
- INSPECTION CRITERION
- PRECAUTIONS FOR USING LCD MODULES
- USING LCD MODULES
- PRIOR CONSULT MATTER

**■ GENERAL INFORMATION**

Item	Contents	Unit/Note
LCD type	TFT/TRANSMISSIVE/POSITIVE	/
Viewing direction	6:00	O'Clock
Gray scale inversion direction	12:00	O'Clock
Module area (W × H)	50.2×69.3×4.0	mm <sup>2</sup>
Active area (W×H)	43.2×57.6	mm <sup>2</sup>
Number of Dots	240(RGB)×320	/
Pixel pitch(W × H)	0.18 × 0.18	mm <sup>2</sup>
DriverIC	ILI9341	/
Colors	65K/262K	/
Backlight Type	4 LEDs	/
Module Power consumption	220	mw
InterfaceType	CPU/RGB	/
Input voltage	2.8	V
With/Without TSP	With TSP	/
Weight	24.16	g

Note 1:Viewing direction for best image quality is different from TFT definition, there is a 180 degree shift.

Note 2 : RoHS compliant;

Note 3: LCM weight tolerance: ± 5% .



**■ ABSOLUTE MAXIMUM RATINGS**

Parameter	Symbol	Min	Max	Unit
Power supply voltage	VCI	-0.3	4.6	V
Logic signal voltage	VDDI	-0.3	4.6	V
Operating temperature	Top	-20	70	°C
Storage temperature	TST	-30	80	°C
Humidity	RH	-	90%(Max60°C)	RH

**■ ELECTRICAL CHARACTERISTICS**

## DC CHARACTERISTICS

Parameter	Symbol	Min	Typ	Max	Unit
Power supply voltage	VCI	2.5	2.8	3.3	V
Logic signal/O voltage	VDDI	1.65	2.8	3.3	V
Input voltage'H'level	VIH	0.7VDDI	-	VDDI	V
Input voltage'L'level	VIL	VSS	-	0.3VDDI	V
Output voltage'H'level	VOH	0.8VDDI	-	VDDI	V
Output voltage'L'level	VOL	VSS0	-	0.2VDDI	V

Note:

1: Display full white. Backlight on state.

2: IC on standby mode.

3: the default voltage is 2.8V, for N lights in series, the power is that the current multiply N.

**■ BACKLIGHT CHARACTERISTICS**

Item	Symbol	Condition	Min	Typ	Max	Unit	Note
Supply voltage	Vf	If=80mA	-	3.2	3.4	v	
Supply current	-	-	-	-	-	mA	
Reverse voltage	Vr	-	-	-	-	v	
Forward current	Normal	4-chip Parallel		80	-	mA	1
	Dimming			I <sub>pd</sub>			
Reverse Current	I <sub>r</sub>	-	-	-	-	μA	
Uniformity	ΔBp		80%				
Color coordinate*	X	I <sub>f</sub> =80mA	0.270	-	0.315	-	
	Y		0.270	-	0.315	-	

White LED CIRCUIT DIAGRAM:

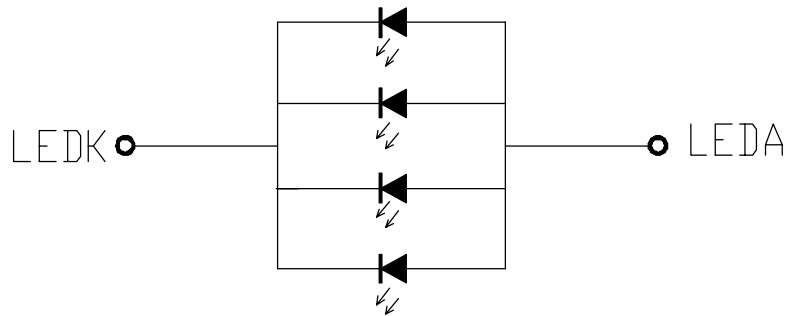

CIRCUIT DIAGRAM  
If=80mA,Constant Current

**NOTE:**

- 1 The LED 's driver mode needs to be constant current mode.
- 2 Permanent damage to the device may occur if maximum values are exceeded or reverse voltage is loaded .Functional operation should be restricted to the conditions described under normal operating conditions.

## ■ELECTRO-OPTICAL CHARACTERISTICS

Item	Symbol	Condition	Min	Typ	Max	Unit	Remark	Note
Response time	Tr +Tf	$\theta=0^\circ$ $\varnothing=0^\circ$ Ta=25°C	-	25	30	ms	Fig.1	4
Contrastratio	Cr		-	500	-	—	FIG 2.	1
Luminance uniformity	$\delta$ WHITE		80	90.8	-	%	FIG 2.	3
Surface Luminance	Lv		150	240	-	cd/m <sup>2</sup>	FIG 2.	2
Viewing angle range	$\theta$	$\varnothing = 90^\circ$	-	70	-	deg	FIG 3.	6
		$\varnothing = 270^\circ$	-	57	-	deg	FIG 3.	
		$\varnothing = 0^\circ$	-	70	-	deg	FIG 3.	
		$\varnothing = 180^\circ$	-	70	-	deg	FIG 3.	
CIE (x, y) chromaticity	Red x	$\theta=0^\circ$ $\varnothing=0^\circ$ Ta=25°C	-	0.6368	-		FIG 2.	5
	Red y		-	0.3329	-			
	Green x		-	0.3397	-			
	Green y		-	0.6138	-			
	Blue x		-	0.1433	-			
	Blue y		-	0.0807	-			
	White x		-	0.2886	-			
	White y		-	0.3194	-			
NTSC Ratio	S		55	67	-	%		

Note 1. Contrast Ratio(CR) is defined mathematically as For more information see FIG 2.:

$$\text{Contrast Ratio} = \frac{\text{Average Surface Luminance with all white pixels (P}_1, \text{P}_2, \text{P}_3, \text{P}_4, \text{P}_5)}{\text{Average Surface Luminance with all black pixels (P}_1, \text{P}_2, \text{P}_3, \text{P}_4, \text{P}_5)}$$

Note 2. Surface luminance is the LCD surface from the surface with all pixels displaying white. For more information see FIG 2.

$$L_v = \text{Average Surface Luminance with all white pixels (P}_1, \text{P}_2, \text{P}_3, \text{P}_4, \text{P}_5)$$

Note 3. The uniformity in surface luminance,  $\delta$  WHITE is determined by measuring luminance at each test position 1 through 5, and then dividing the maximum luminance of 5 points luminance by minimum luminance of 5 points luminance. For more information see FIG 2.

$$\delta \text{ WHITE} = \frac{\text{Minimum Surface Luminance with all white pixels (P}_1, \text{P}_2, \text{P}_3, \text{P}_4, \text{P}_5)}{\text{Maximum Surface Luminance with all white pixels (P}_1, \text{P}_2, \text{P}_3, \text{P}_4, \text{P}_5)}$$

Note 4. Response time is the time required for the display to transition from White to black(Rise Time, Tr) and from black to white(Decay Time, Tf). For additional information see FIG 1. The test equipment is Autronic-Melchers's ConoScope. Series

Note 5. CIE (x, y) chromaticity, The x,y value is determined by measuring luminance at each test position 1 through 5, and then make average value

Note 6. Viewing angle is the angle at which the contrast ratio is greater than 2. For TFT module the contrast ratio is greater than 10. The angles are determined for the horizontal or x axis and the vertical or y axis with respect to the z axis which is normal to the LCD surface. For more information see FIG 3.

Note 7. For Viewing angle and response time testing, the testing data is base on Autronic-Melchers's ConoScope. Series Instruments. For contrast ratio, Surface Luminance, Luminance uniformity, CIE The test data is base on TOPCON's BM-5 photo detector.

Note 8. For TFT module, Gray scale reverse occurs in the direction of panel viewing angle.



FIG.1. The definition of Response Time

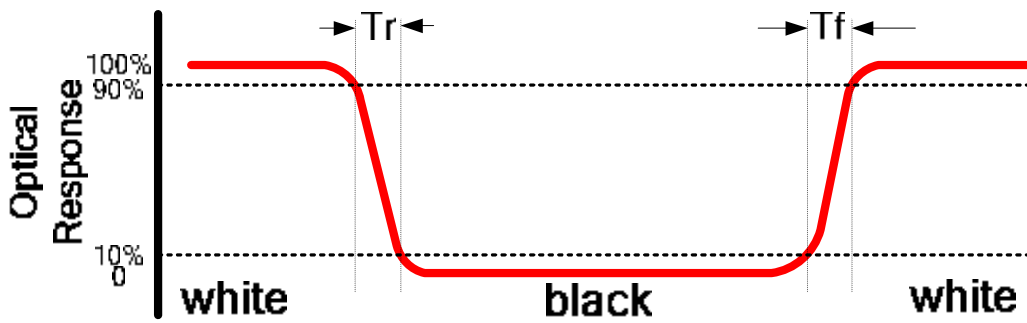

FIG.2. Measuring method for Contrast ratio, surface luminance, Luminance uniformity, CIE (x, y) chromaticity

A : 5 mm  
 B : 5 mm  
 H, V : Active Area  
 Light spot size  $\varnothing=5\text{mm}$ , 500mm distance from the LCD surface to detector lens  
 measurement instrument is TOPCON's luminance meter BM-5

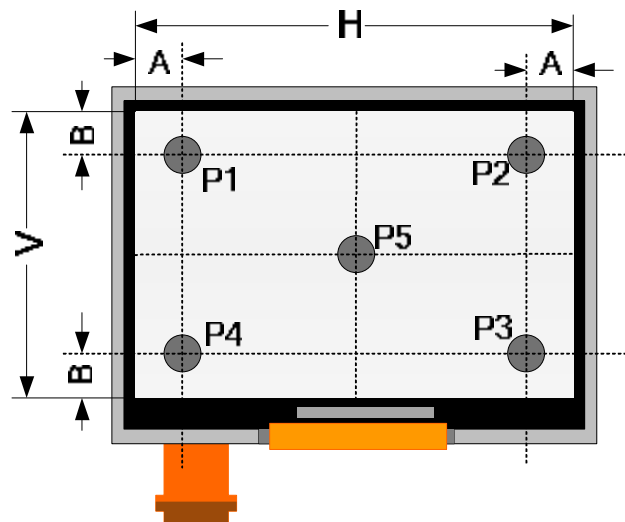
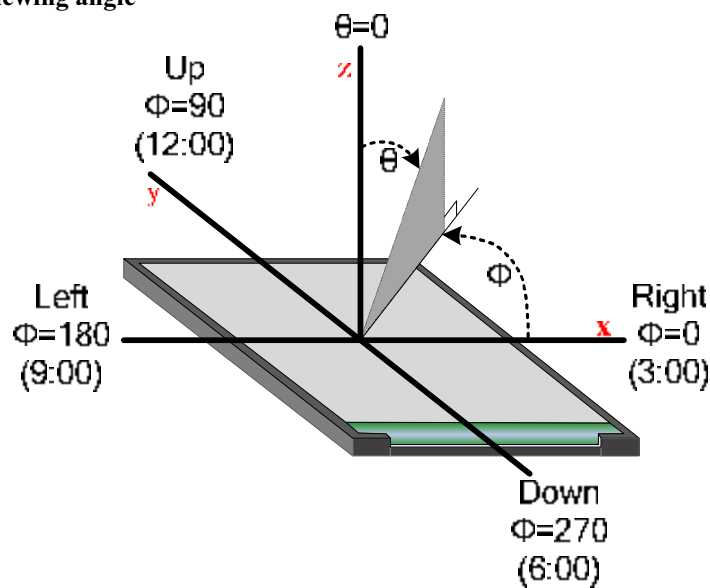

FIG.3. The definition of viewing angle





## ■ INTERFACE DESCRIPTION

Pin No.	Symbol	I/O	Function
1	LEDK	I	Cathode for LED backlighting
2	LEDA1	I	Anode No.1 for LED backlighting
3	LEDA2	I	Anode No.2 for LED backlighting
4	LEDA3	I	Anode No.3 for LED backlighting
5	LEDA4	I	Anode No.4 for LED backlighting
6	IM0	I	Select Interface Mode ;Note1
7	IM1	I	
8	IM2	I	
9	IM3	I	
10	RESET	I	Reset pin
11	VSYNC	IO	Frame Synchronizing Signal For RGB Interface
12	HSYNC	IO	Line Synchronizing Signal For RGB Interface
13	DOTCLK	IO	Dot Clock Signal For RGB Interface
14	DE	IO	Data Enable Signal For RGB Interface
15	DB17	IO	DATA BUS
32	DB0		
33	SDO	IO	Serial Output Signal
34	SDI	IO	Serial Input Signal
35	RD	IO	Read execution control pin
36	WRX(D/CX)	IO	Write execution control pin ; Serial Register select s Signal
37	D/CX(SCL)	IO	Register select signal; Serial Interface Clock
38	CSX	IO	Chip Select Signal
39	TE	IO	Tearing effect out pin synchronize MPU to frame writng
40	VDDI	P	Power Supply to the interface pins ,provide with 2.8V
41	VDDI	P	Power Supply to the interface pins ,provide with 2.8V
42	VCI	P	Logic power ,provide with 2.8V
43	GND	G	Ground
44	X+	O	Touch panel output
45	Y+	O	Touch panel output
46	X-	O	Touch panel output
47	Y-	O	Touch panel output
48	GND	O	Ground
49	GND	O	Ground
50	GND	-	Ground



NOTE1:

IM3	IM2	IM1	IM0	MCU-Interface Mode	Pins in use	
					Register/Content	GRAM
0	0	0	0	8080 MCU 8-bit bus interface I	D[7:0]	D[7:0],WRX,RDX,CSX,D/CX
0	0	0	1	8080 MCU 16-bit bus interface I	D[7:0]	D[15:0],WRX,RDX,CSX,D/CX
0	0	1	0	8080 MCU 9-bit bus interface I	D[7:0]	D[8:0],WRX,RDX,CSX,D/CX
0	0	1	1	8080 MCU 18-bit bus interface I	D[7:0]	D[17:0],WRX,RDX,CSX,D/CX
0	1	0	1	3-wire 9-bit data serial interface I	SCL,SDA,CSX	
0	1	1	0	4-wire 8-bit data serial interface I	SCL,SDA,D/CX,CSX	
1	0	0	0	8080 MCU 16-bit bus interface II	D[8:1]	D[17:10],D[8:1],WRX,RDX,CSX,D/CX
1	0	0	1	8080 MCU 8-bit bus interface II	D[17:10]	D[17:10],WRX,RDX,CSX,D/CX
1	0	1	0	8080 MCU 18-bit bus interface II	D[8:1]	D[17:0],WRX,RDX,CSX,D/CX
1	0	1	1	8080 MCU 9-bit bus interface II	D[17:10]	D[17:9],WRX,RDX,CSX,D/CX
1	1	0	1	3-wire 9-bit data serial interface II	SCL,SDI,SDO, CSX	
1	1	1	0	4-wire 8-bit data serial interface II	SCL,SDI,D/CX,SDO, CSX	

## APPLICATION NOTES

### 1.1 Interface Timing Chart

Note: Please refer to ILITEK's [ILI9341](#) data sheet for more details.

ILITEK's [ILI9341](#) INTERFACE PROTOCOL Inter 80 system CPU interface

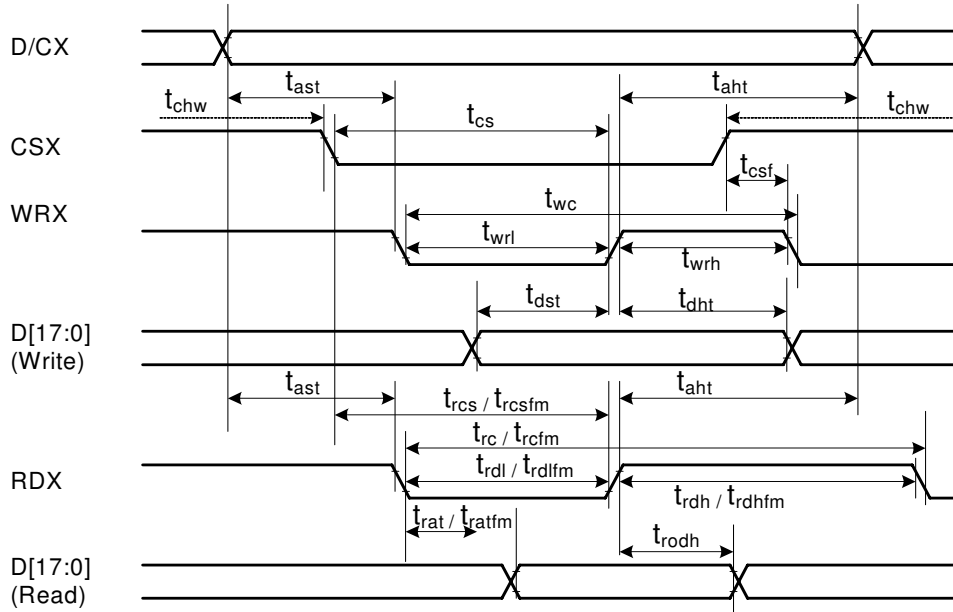

Signal	Symbol	Parameter	min	max	Unit	Description
DCX	tast	Address setup time	0	-	ns	
	taht	Address hold time (Write/Read)	0	-	ns	
CSX	tchw	CSX "H" pulse width	0	-	ns	
	tcs	Chip Select setup time (Write)	15	-	ns	
	trcs	Chip Select setup time (Read ID)	45	-	ns	
	trcsfm	Chip Select setup time (Read FM)	355	-	ns	
	tcsf	Chip Select Wait time (Write/Read)	10	-	ns	
WRX	twc	Write cycle	66	-	ns	
	twrh	Write Control pulse H duration	15	-	ns	
	twrl	Write Control pulse L duration	15	-	ns	
RDX (FM)	trcfm	Read Cycle (FM)	450	-	ns	
	trdhfm	Read Control H duration (FM)	90	-	ns	
	trdlfm	Read Control L duration (FM)	355	-	ns	
RDX (ID)	trc	Read cycle (ID)	160	-	ns	
	trdh	Read Control pulse H duration	90	-	ns	
	trdl	Read Control pulse L duration	45	-	ns	
D[17:0], D[17:10]&D[8:1], D[17:10], D[17:9]	tdst	Write data setup time	10	-	ns	For maximum CL=30pF For minimum CL=8pF
	tdht	Write data hold time	10	-	ns	
	trat	Read access time	-	40	ns	
	tratfm	Read access time	-	340	ns	
	trodh	Read output disable time	20	80	ns	

Note:  $T_a = -30$  to  $70$  °C,  $V_{DDI} = 1.65V$  to  $3.3V$ ,  $V_{CI} = 2.5V$  to  $3.3V$ ,  $V_{SS} = 0V$ .

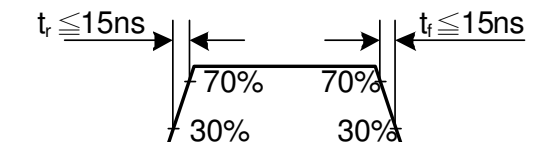



INSTRUCTION DESCRIPTION(ILITEK's ILI9341)

Regulative Command Set													
Command Function	D/CX	RDX	WRX	D17-8	D7	D6	D5	D4	D3	D2	D1	D0	Hex
No Operation	0	1	↑	XX	0	0	0	0	0	0	0	0	00h
Software Reset	0	1	↑	XX	0	0	0	0	0	0	0	1	01h
Read Display Identification Information	0	1	↑	XX	0	0	0	0	0	1	0	0	04h
	1	↑	1	XX	X	X	X	X	X	X	X	X	XX
	1	↑	1	XX	ID1 [7:0]							XX	
	1	↑	1	XX	ID2 [7:0]							XX	
	1	↑	1	XX	ID3 [7:0]							XX	
Read Display Status	0	1	↑	XX	0	0	0	0	1	0	0	1	09h
	1	↑	1	XX	X	X	X	X	X	X	X	X	XX
	1	↑	1	XX	D [31:25]							X	00
	1	↑	1	XX	X	D [22:20]			D [19:16]			61	
	1	↑	1	XX	X	X	X	X	X	D [10:8]			00
	1	↑	1	XX	D [7:5]			X	X	X	X	X	00
Read Display Power Mode	0	1	↑	XX	0	0	0	0	1	0	1	0	0Ah
	1	↑	1	XX	X	X	X	X	X	X	X	X	XX
	1	↑	1	XX	D [7:2]						0	0	08
Read Display MADCTL	0	1	↑	XX	0	0	0	0	1	0	1	1	0Bh
	1	↑	1	XX	X	X	X	X	X	X	X	X	XX
	1	↑	1	XX	D [7:2]						0	0	00
Read Display Pixel Format	0	1	↑	XX	0	0	0	0	1	1	0	0	0Ch
	1	↑	1	XX	X	X	X	X	X	X	X	X	XX
	1	↑	1	XX	RIM	DPI [2:0]			X	DBI [2:0]			06
Read Display Image Format	0	1	↑	XX	0	0	0	0	1	1	0	1	0Dh
	1	↑	1	XX	X	X	X	X	X	X	X	X	XX
	1	↑	1	XX	X	X	X	X	X	D [2:0]			00
Read Display Signal Mode	0	1	↑	XX	0	0	0	0	1	1	1	0	0Eh
	1	↑	1	XX	X	X	X	X	X	X	X	X	XX
	1	↑	1	XX	D [7:2]						0	0	00
Read Display Self-Diagnostic Result	0	1	↑	XX	0	0	0	0	1	1	1	1	0Fh
	1	↑	1	XX	X	X	X	X	X	X	X	X	XX
	1	↑	1	XX	D [7:6]			X	X	X	X	X	00
Enter Sleep Mode	0	1	↑	XX	0	0	0	1	0	0	0	0	10h
Sleep OUT	0	1	↑	XX	0	0	0	1	0	0	0	1	11h
Partial Mode ON	0	1	↑	XX	0	0	0	1	0	0	1	0	12h
Normal Display Mode ON	0	1	↑	XX	0	0	0	1	0	0	1	1	13h
Display Inversion OFF	0	1	↑	XX	0	0	1	0	0	0	0	0	20h
Display Inversion ON	0	1	↑	XX	0	0	1	0	0	0	0	1	21h
Gamma Set	0	1	↑	XX	0	0	1	0	0	1	1	0	26h
	1	1	↑	XX	GC [7:0]							01	
Display OFF	0	1	↑	XX	0	0	1	0	1	0	0	0	28h
Display ON	0	1	↑	XX	0	0	1	0	1	0	0	1	29h
Column Address Set	0	1	↑	XX	0	0	1	0	1	0	1	0	2Ah
	1	1	↑	XX	SC [15:8]							XX	
	1	1	↑	XX	SC [7:0]							XX	
	1	1	↑	XX	EC [15:8]							XX	
	1	1	↑	XX	EC [7:0]							XX	
Page Address Set	0	1	↑	XX	0	0	1	0	1	0	1	1	2Bh
	1	1	↑	XX	SP [15:8]							XX	
	1	1	↑	XX	SP [7:0]							XX	
	1	1	↑	XX	EP [15:8]							XX	
	1	1	↑	XX	EP [7:0]							XX	



Memory Write	0	1	↑	XX	0	0	1	0	1	1	0	0	2Ch
	1	1	↑		D [17:0]								XX
Color SET	0	1	↑	XX	0	0	1	0	1	1	0	1	2Dh
	1	↑	1	XX							R00 [5:0]		XX
	1	↑	1	XX							Rnn [5:0]		XX
	1	↑	1	XX							R31 [5:0]		XX
	1	↑	1	XX							G00 [5:0]		XX
	1	↑	1	XX							Gnn [5:0]		XX
	1	↑	1	XX							G64 [5:0]		XX
	1	↑	1	XX							B00 [5:0]		XX
	1	↑	1	XX							Bnn [5:0]		XX
	1	↑	1	XX							B31 [5:0]		XX
Memory Read	0	1	↑	XX	0	0	1	0	1	1	1	0	2Eh
	1	↑	1	XX	X	X	X	X	X	X	X	X	XX
	1	↑	1		D [17:0]								XX
Partial Area	0	1	↑	XX	0	0	1	1	0	0	0	0	30h
	1	1	↑	XX							SR [15:8]		00
	1	1	↑	XX							SR [7:0]		00
	1	1	↑	XX							ER [15:8]		01
	1	1	↑	XX							ER [7:0]		3F
Vertical Scrolling Definition	0	1	↑	XX	0	0	1	1	0	0	1	1	33h
	1	1	↑	XX							TFA [15:8]		00
	1	1	↑	XX							TFA [7:0]		00
	1	1	↑	XX							VSA [15:8]		01
	1	1	↑	XX							VSA [7:0]		40
	1	1	↑	XX							BFA [15:8]		00
1	1	↑	XX							BFA [7:0]		00	
Tearing Effect Line OFF	0	1	↑	XX	0	0	1	1	0	1	0	0	34h
Tearing Effect Line ON	0	1	↑	XX	0	0	1	1	0	1	0	1	35h
	1	1	↑	XX	X	X	X	X	X	X	X	M	00
Memory Access Control	0	1	↑	XX	0	0	1	1	0	1	1	0	36h
	1	1	↑	XX	MY	MX	MV	ML	BGR	MH	X	X	00
Vertical Scrolling Start Address	0	1	↑	XX	0	0	1	1	0	1	1	1	37h
	1	1	↑	XX							VSP [15:8]		00
	1	1	↑	XX							VSP [7:0]		00
Idle Mode OFF	0	1	↑	XX	0	0	1	1	1	0	0	0	38h
Idle Mode ON	0	1	↑	XX	0	0	1	1	1	0	0	1	39h
Pixel Format Set	0	1	↑	XX	0	0	1	1	1	0	1	0	3Ah
	1	1	↑	XX	X		DPI [2:0]		X		DBI [2:0]		66
Write Memory Continue	0	1	↑	XX	0	0	1	1	1	1	0	0	3Ch
	1	1	↑		D [17:0]								XX
Read Memory Continue	0	1	↑	XX	0	0	1	1	1	1	1	0	3Eh
	1	↑	1	XX	X	X	X	X	X	X	X	X	XX
	1	↑	1		D [17:0]								XX
Set Tear Scanline	0	1	↑	XX	0	1	0	0	0	1	0	0	44h
	1	1	↑	XX	X	X	X	X	X	X	X	STS [8]	00
	1	1	↑	XX							STS [7:0]		00
Get Scanline	0	1	↑	XX	0	1	0	0	0	1	0	1	45h
	1	↑	1	XX	X	X	X	X	X	X	X	X	XX
	1	↑	1	XX	X	X	X	X	X	X	GTS [9:8]		00
	1	↑	1	XX							GTS [7:0]		00
Write Display Brightness	0	1	↑	XX	0	1	0	1	0	0	0	1	51h
	1	1	↑	XX							DBV [7:0]		00



Read Display Brightness	0	1	↑	XX	0	1	0	1	0	0	1	0	52h
	1	↑	1	XX	X	X	X	X	X	X	X	X	XX
	1	↑	1	XX	DBV [7:0]								00
Write CTRL Display	0	1	↑	XX	0	1	0	1	0	0	1	1	53h
	1	1	↑	XX	X	X	BCTRL	X	DD	BL	X	X	00
Read CTRL Display	0	1	↑	XX	0	1	0	1	0	1	0	0	54h
	1	↑	1	XX	X	X	X	X	X	X	X	X	XX
	1	↑	1	XX	X	X	BCTRL	X	DD	BL	X	X	00
Write Content Adaptive Brightness Control	0	1	↑	XX	0	1	0	1	0	1	0	1	55h
	1	1	↑	XX	X	X	X	X	X	X	C [1:0]		00
Read Content Adaptive Brightness Control	0	1	↑	XX	0	1	0	1	0	1	1	0	56h
	1	↑	1	XX	X	X	X	X	X	X	X	X	XX
	1	↑	1	XX	X	X	X	X	X	X	C [1:0]		00
Write CABC Minimum Brightness	0	1	↑	XX	0	1	0	1	1	1	1	0	5Eh
	1	1	↑	XX	CMB [7:0]								00
Read CABC Minimum Brightness	0	1	↑	XX	0	1	0	1	0	1	1	1	5Fh
	1	↑	1	XX	X	X	X	X	X	X	X	X	XX
	1	↑	1	XX	CMB [7:0]								00
Read ID1	0	1	↑	XX	1	1	0	1	1	0	1	0	DAh
	1	↑	1	XX	X	X	X	X	X	X	X	X	XX
	1	↑	1	XX	Module's Manufacture [7:0]								XX
Read ID2	0	1	↑	XX	1	1	0	1	1	0	1	1	DBh
	1	↑	1	XX	X	X	X	X	X	X	X	X	XX
	1	↑	1	XX	LCD Module / Driver Version [7:0]								XX
Read ID3	0	1	↑	XX	1	1	0	1	1	1	0	0	DCh
	1	↑	1	XX	X	X	X	X	X	X	X	X	XX
	1	↑	1	XX	LCD Module / Driver ID [7:0]								XX

Extended Command Set													
Command Function	D/CX	RDX	WRX	D17-8	D7	D6	D5	D4	D3	D2	D1	D0	Hex
RGB Interface Signal Control	0	1	↑	XX	1	0	1	1	0	0	0	0	B0h
	1	1	↑	XX	ByPass_MODE	RCM [1:0]		X	VSPL	HSPL	DPL	EPL	40
Frame Control (In Normal Mode)	0	1	↑	XX	1	0	1	1	0	0	0	1	B1h
	1	1	↑	XX	X	X	X	X	X	X	DIVA [1:0]		00
	1	1	↑	XX	X	X	X	RTNA [4:0]					1B
Frame Control (In Idle Mode)	0	1	↑	XX	1	0	1	1	0	0	1	0	B2h
	1	1	↑	XX	X	X	X	X	X	X	DIVB [1:0]		00
	1	1	↑	XX	X	X	X	RTNB [4:0]					1B
Frame Control (In Partial Mode)	0	1	↑	XX	1	0	1	1	0	0	1	1	B3h
	1	1	↑	XX	X	X	X	X	X	X	DIVC [1:0]		00
	1	1	↑	XX	X	X	X	RTNC [4:0]					1B
Display Inversion Control	0	1	↑	XX	1	0	1	1	0	1	0	0	B4h
	1	1	↑	XX	X	X	X	X	X	NLA	NLB	NLC	02
Blanking Porch Control	0	1	↑	XX	1	0	1	1	0	1	0	1	B5h
	1	1	↑	XX	0	VFP [6:0]						02	
	1	1	↑	XX	0	VBP [6:0]						02	
	1	1	↑	XX	0	0	0	HFP [4:0]				0A	
	1	1	↑	XX	0	0	0	HBP [4:0]				14	



Display Function Control	0	1	↑	XX	1	0	1	1	0	1	1	0	B6h
	1	1	↑	XX	X	X	X	X	PTG [1:0]		PT [1:0]		0A
	1	1	↑	XX	REV	GS	SS	SM	ISC [3:0]			82	
	1	1	↑	XX	X	X	NL [5:0]						27
	1	1	↑	XX	X	X	PCDIV [5:0]						XX
Entry Mode Set	0	1	↑	XX	1	0	1	1	0	1	1	1	B7h
	1	1	↑	XX	X	X	X	X	DSTB	GON	DTE	GAS	07
Backlight Control 1	0	1	↑	XX	1	0	1	1	1	0	0	0	B8h
	1	1	↑	XX	X	X	X	X	X	X	X	X	XX
	1	1	↑	XX	X	X	X	X	TH_UI [3:0]			04	
Backlight Control 2	0	1	↑	XX	1	0	1	1	1	0	0	1	B9h
	1	1	↑	XX	X	X	X	X	X	X	X	X	XX
	1	1	↑	XX	TH_MV [3:0]			TH_ST [3:0]				B8	
Backlight Control 3	0	1	↑	XX	1	0	1	1	1	0	1	0	BAh
	1	1	↑	XX	X	X	X	X	X	X	X	X	XX
	1	1	↑	XX	X	X	X	X	DTH_UI [3:0]			04	
Backlight Control 4	0	1	↑	XX	1	0	1	1	1	0	1	1	BBh
	1	1	↑	XX	X	X	X	X	X	X	X	X	XX
	1	1	↑	XX	DTH_MV [3:0]			DTH_ST [3:0]				C9	
Backlight Control 5	0	1	↑	XX	1	0	1	1	1	1	0	0	BCh
	1	1	↑	XX	X	X	X	X	X	X	X	X	XX
	1	1	↑	XX	DIM2 [3:0]			X	DIM1 [2:0]			44	
Backlight Control 7	0	1	↑	XX	1	0	1	1	1	1	1	0	BEh
	1	1	↑	XX	PWM_DIV [7:0]							0F	
Backlight Control 8	0	1	↑	XX	1	0	1	1	1	1	1	1	BFh
	1	1	↑	XX	X	X	X	X	X	LEDONR	LEDONPOL	LEDPWMOPL	00
Power Control 1	0	1	↑	XX	1	1	0	0	0	0	0	0	C0h
	1	1	↑	XX	X	X	VRH [5:0]					26	
Power Control 2	0	1	↑	XX	1	1	0	0	0	0	0	1	C1h
	1	1	↑	XX	X	X	X	X	X	BT [2:0]			00
VCOM Control 1	0	1	↑	XX	1	1	0	0	0	1	0	1	C5h
	1	1	↑	XX	X	VMH [6:0]						31	
	1	1	↑	XX	X	VML [6:0]						3C	
VCOM Control 2	0	1	↑	XX	1	1	0	0	0	1	1	1	C7h
	1	1	↑	XX	nVM	VMF [6:0]						C0	
NV Memory Write	0	1	↑	XX	1	1	0	1	0	0	0	0	D0h
	1	1	↑	XX	X	X	X	X	X	PGM_ADR [2:0]			00
	1	1	↑	XX	PGM_DATA [7:0]							XX	
NV Memory Protection Key	0	1	↑	XX	1	1	0	1	0	0	0	1	D1h
	1	1	↑	XX	KEY [23:16]							55	
	1	1	↑	XX	KEY [15:8]							AA	
	1	1	↑	XX	KEY [7:0]							66	
NV Memory Status Read	0	1	↑	XX	1	1	0	1	0	0	1	0	D2h
	1	↑	1	XX	X	X	X	X	X	X	X	X	XX
	1	↑	1	XX	X	ID2_CNT [2:0]		X	ID1_CNT [2:0]		XX		
	1	↑	1	XX	BUSY	VMF_CNT [2:0]		X	ID3_CNT [2:0]		XX		





Read ID4	0	↑	1	XX	1	1	0	1	0	0	1	1	D3h
	1	↑	1	XX	X	X	X	X	X	X	X	X	XX
	1	↑	1	XX	0	0	0	0	0	0	0	0	00
	1	↑	1	XX	1	0	0	1	0	0	1	1	93
	1	↑	1	XX	0	1	0	0	0	0	0	1	41
Positive Gamma Correction	0	1	↑	XX	1	1	1	0	0	0	0	0	E0h
	1	1	↑	XX	X	X	X	X	VP0 [3:0]			08	
	1	1	↑	XX	X	X	VP1 [5:0]					0E	
	1	1	↑	XX	X	X	VP2 [5:0]					12	
	1	1	↑	XX	X	X	X	X	VP4 [3:0]			05	
	1	1	↑	XX	X	X	X	VP6 [4:0]				03	
	1	1	↑	XX	X	X	X	X	VP13 [3:0]			09	
	1	1	↑	XX	X	VP20 [6:0]						47	
	1	1	↑	XX	VP36 [3:0]			VP27 [3:0]			86		
	1	1	↑	XX	X	VP43 [6:0]						2B	
	1	1	↑	XX	X	X	X	X	VP50 [3:0]			0B	
	1	1	↑	XX	X	X	X	VP57 [4:0]				04	
	1	1	↑	XX	X	X	X	X	VP59 [3:0]			00	
	1	1	↑	XX	X	X	VP61 [5:0]					00	
	1	1	↑	XX	X	X	VP62 [5:0]					00	
1	1	↑	XX	X	X	X	X	VP63 [3:0]			00		
Negative Gamma Correction	0	1	↑	XX	1	1	1	0	0	0	0	1	E1h
	1	1	↑	XX	X	X	X	X	VN0 [3:0]			08	
	1	1	↑	XX	X	X	VN1 [5:0]					1A	
	1	1	↑	XX	X	X	VN2 [5:0]					20	
	1	1	↑	XX	X	X	X	X	VN4 [3:0]			07	
	1	1	↑	XX	X	X	X	VN6 [4:0]				0E	
	1	1	↑	XX	X	X	X	X	VN13 [3:0]			05	
	1	1	↑	XX	X	VN20 [6:0]						3A	
	1	1	↑	XX	VN36 [3:0]			VN27 [3:0]			8A		
	1	1	↑	XX	X	VN43 [6:0]						40	
	1	1	↑	XX	X	X	X	X	VN50 [3:0]			04	
	1	1	↑	XX	X	X	X	VN57 [4:0]				18	
	1	1	↑	XX	X	X	X	X	VN59 [3:0]			0F	
	1	1	↑	XX	X	X	VN61 [5:0]					3F	
	1	1	↑	XX	X	X	VN62 [5:0]					3F	
1	1	↑	XX	X	X	X	X	VN63 [3:0]			0F		
Digital Gamma Control 1	0	1	↑	XX	1	1	1	0	0	0	1	0	E2h
1 <sup>st</sup> Parameter	1	1	↑	XX	RCA0 [3:0]			BCA0 [3:0]			XX		
:	1	1	↑	XX	RCAx [3:0]			BCAx [3:0]			XX		
16 <sup>th</sup> Parameter	1	1	↑	XX	RCA15 [3:0]			BCA15 [3:0]			XX		
Digital Gamma Control 2	0	1	↑	XX	1	1	1	0	0	0	1	1	E3h
1 <sup>st</sup> Parameter	1	1	↑	XX	RFA0 [3:0]			BFA0 [3:0]			XX		
:	1	1	↑	XX	RFAx [3:0]			BFAX [3:0]			XX		
64 <sup>th</sup> Parameter	1	1	↑	XX	RFA63 [3:0]			BFA63 [3:0]			XX		
Interface Control	0	1	↑	XX	1	1	1	1	0	1	1	0	F6h
	1	1	↑	XX	MY_EOR	MX_EOR	MV_EOR	X	BGR_EOR	X	X	WEMODE	01
	1	1	↑	XX	X	X	EPF [1:0]		X	X	MDT [1:0]		00
	1	1	↑	XX	X	X	ENDIAN	X	DM [1:0]	RM	RIM	00	

Note 1: Undefined commands are treated as NOP (00h) command.

Note 2: B0 to D9 and DE to FF are for factory use of display supplier. USER can decide if these commands are available or they are treated as NOP (00h) commands before shipping to USER. Default value is NOP (00h).

Note 3: Commands 10h, 12h, 13h, 26h, 28h, 29h, 30h, 36h (Bit B4 only), 38h and 39h are updated during V-SYNC when ILI9341 is in Sleep OUT mode to avoid abnormal visual effects. During Sleep IN mode, these commands are updated immediately. Read status (09h), Read display power mode (0Ah), Read display MADCTL (0Bh), Read display pixel format (0Ch), Read display image mode (0Dh), Read display signal mode (0Eh) and Read display self diagnostic result (0Fh) of these commands are updated immediately both in Sleep IN mode and Sleep OUT mode.

## ■ INITIAL CODE

```

code void INIT()
{
    write_cmd(0x01); //software reset
    delay(5);
    write_cmd(0x28); // display off
//-----
    write_cmd(0xcf);
    write_data16(0x00,0x00);
    write_data16(0x00,0x83);
    write_data16(0x00,0x30);

    write_cmd(0xed);
    write_data16(0x00,0x64);
    write_data16(0x00,0x03);
    write_data16(0x00,0x12);
    write_data16(0x00,0x81);

    write_cmd(0xe8);
    write_data16(0x00,0x85);
    write_data16(0x00,0x01);
    write_data16(0x00,0x79);

    write_cmd(0xcb);
    write_data16(0x00,0x39);
    write_data16(0x00,0x2c);
    write_data16(0x00,0x00);
    write_data16(0x00,0x34);
    write_data16(0x00,0x02);

    write_cmd(0xf7);
    write_data16(0x00,0x20);

    write_cmd(0xea);
    write_data16(0x00,0x00);
    write_data16(0x00,0x00);

//-----power control-----
    write_cmd(0xc0); //power control
    write_data16(0x00,0x26);

    write_cmd(0xc1); //power control
    write_data16(0x00,0x11);
//-----VCOM设定不符合开机会闪烁 -----
    write_cmd(0xc5); //vcom control
    write_data16(0x00,0x35);//35
    write_data16(0x00,0x3e);//3E

    write_cmd(0xc7); //vcom control
    write_data16(0x00,0xbe);// 0x94
//-----memory access control-----
    write_cmd(0x36); // memory access control
    write_data16(0x00,0x48); //0048 my,mx,mv,ml,BGR,mh,0.0

    write_cmd(0x3a); // pixel format set
    write_data16(0x00,0x55);//16bit /pixel
//----- frame rate-----
    write_cmd(0xb1); // frame rate
    write_data16(0x00,0x00);
    write_data16(0x00,0x1B); //70

//-----Gamma-----
    write_cmd(0xf2); // 3Gamma Function Disable
    write_data16(0x00,0x08);

    write_cmd(0x26);
    write_data16(0x00,0x01); // gamma set 4 gamma curve 01/02/04/08

```



```
write_cmd(0xE0); //positive gamma correction
write_data16(0x00,0x1f);
write_data16(0x00,0x1a);
write_data16(0x00,0x18);
write_data16(0x00,0x0a);
write_data16(0x00,0x0f);
write_data16(0x00,0x06);
write_data16(0x00,0x45);
write_data16(0x00,0x87);
write_data16(0x00,0x32);
write_data16(0x00,0x0a);
write_data16(0x00,0x07);
write_data16(0x00,0x02);
write_data16(0x00,0x07);
write_data16(0x00,0x05);
write_data16(0x00,0x00);

write_cmd(0xE1); //negamma correction
write_data16(0x00,0x00);
write_data16(0x00,0x25);
write_data16(0x00,0x27);
write_data16(0x00,0x05);
write_data16(0x00,0x10);
write_data16(0x00,0x09);
write_data16(0x00,0x3a);
write_data16(0x00,0x78);
write_data16(0x00,0x4d);
write_data16(0x00,0x05);
write_data16(0x00,0x18);
write_data16(0x00,0x0d);
write_data16(0x00,0x38);
write_data16(0x00,0x3a);
write_data16(0x00,0x1f);
//-----ddram-----
write_cmd(0x2a); // column set
write_data16(0x00,0x00);
write_data16(0x00,0x00);
write_data16(0x00,0x00);
write_data16(0x00,0xEF);

write_cmd(0x2b); // page address set
write_data16(0x00,0x00);
write_data16(0x00,0x00);
write_data16(0x00,0x01);
write_data16(0x00,0x3F);

// write_cmd(0x34); // tearing effect off
//write_cmd(0x35); // tearing effect on

//write_cmd(0xb4); // display inversion
//write_data16(0x00,0x00);

write_cmd(0xb7); //entry mode set
write_data16(0x00,0x07);
//-----display-----
write_cmd(0xb6); // display function control
write_data16(0x00,0x0a);
write_data16(0x00,0x82);
write_data16(0x00,0x27);
write_data16(0x00,0x00);

write_cmd(0x11); //sleep out
delay(100);
write_cmd(0x29); // display on
delay(T00);
write_cmd(0x2c); //memory write
}
```

## ■ RELIABILITY TEST

No.	Test Item	Test Condition	Inspection after test
1	High Temperature Storage	80±2℃/96 hours	Inspection after 2~4hours storage at room temperature, the sample shall be free from defects: 1.Air bubble in the LCD; 2.Sealleak; 3.Non-display; 4.missing segments; 5.Glass crack; 6.Current Idd is twice higher than initial value. 7. The surface shall be free from damage. 8.Linearity must be no more than 1.5% by the linearity tester. 9..The Electric characteristics requirements shall be satisfied.
2	Low Temperature Storage	-30±2℃/96 hours	
3	High Temperature Operating	70±2℃/96 hours	
4	Low Temperature Operating	-20±2℃/96 hours	
5	Temperature Cycle	-30±2℃~25~80±2℃×10cycles	
6	Damp Proof Test	60℃±5℃×90%RH/96 hours	
7	Vibration Test	Frequency: 10Hz~55Hz~10Hz Amplitude: 1.5mm, X, Y, Z direction for total 3hours (Packing condition)	
8	Drooping test	Drop to the ground from 1m height, one time, every side of carton. (Packing condition)	
9	ESD test	Voltage:±8KV R: 330Ω C: 150pF Air discharge, 10time	
10	Hitting test	1,000,000 times in the same point, Hitting pad: tip R3.75 mm,Silicone rubber, Hardness:40 deg.; Load: 2.45N; Hitting speed: Twice/sec; Electric load: None; Test area should be at 1.8 mm inside of insulation.	
11	Pen sliding durability test	100, 000 times minimum Hitting pad: tip R0.8 mm Plastic pen; Load: 1.47N; Sliding speed: 60 mm/sec; Electric load: None Test area should be at 1.8 mm inside of insulation.	
Remark: 1.The test samples should be applied to only one test item. 2.Sample size for each test item is 5~10pcs. 3.For Damp Proof Test, Pure water(Resistance>10MΩ) should be used. 4.In case of malfunction defect caused by ESD damage, if it would be recovered to normal state after resetting, it would be judge as a good part. 5.EL evaluation should be excepted from reliability test with humidity and temperature: Some defects such as black spot/blemish can happen by natural chemical reaction with humidity and Fluorescence EL has. 6.Failure Judgment Criterion: Basic Specification, Electrical Characteristic, Mechanical Characteristic, Optical Characteristic.			

**■ INSPECTION CRITERION**

 <p>OUTGOING QUALITY STANDARD</p>	<p>PAGE 1 OF 7</p>
--	--------------------

<p>TITLE:FUNCTIONAL TEST &amp; INSPECTION CRITERIA</p>
--

This specification is made to be used as the standard acceptance/rejection criteria for Color mobile phone LCM with touch panel.

1 Sample plan

Sampling plan according to GB/T2828.1-2003/ISO 2859-1: 1999 and ANSI/ASQC Z1.4-1993, normal level 2 and based on:

Major defect: AQL 0.65

Minor defect: AQL 1.5

2. Inspection condition

Viewing distance for cosmetic inspection is about 30cm with bare eyes, and under an environment of 20~40W light intensity, all directions for inspecting the sample should be within 45° against perpendicular line.

3. Definition of inspection zone in LCD.

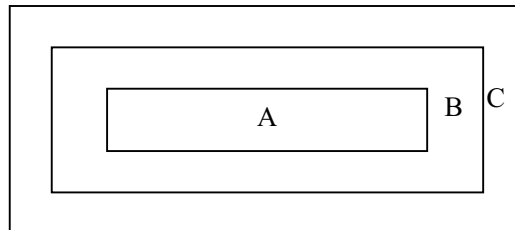

Zone A: character/Digit area

Zone B: viewing area except Zone A (ZoneA+ZoneB=minimum Viewing area)

Zone C: Outside viewing area (invisible area after assembly in customer's product)

Fig.1 Inspection zones in an LCD.

Note: As a general rule, visual defects in Zone C are permissible, when it is no trouble for quality and assembly of customer's product.

	OUTGOING QUALITY STANDARD	PAGE 2 OF 7
---	---------------------------	-------------

TITLE:FUNCTIONAL TEST & INSPECTION CRITERIA
---

#### 4. Inspection standards

##### 4.1 Major Defect

Item No	Items to be inspected	Inspection Standard	Classification of defects
4.1.1	All functional defects	1) No display 2) Display abnormally 3) Missing vertical, horizontal segment 4) Short circuit 5) Back-light no lighting, flickering and abnormal lighting.	Major
4.1.2	Missing	Missing component	
4.1.3	Outline dimension	Overall outline dimension beyond the drawing is not allowed.	
4.1.4	linearity	No more than 1.5%	

##### 4.2 Cosmetic Defect

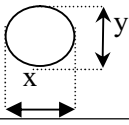
Item No	Items to be inspected	Inspection Standard	Classification of defects																							
4.2.1	<b>Clear Spots</b>  Black and white Spot defect  Pinhole,  Foreign Particle,  polarizer Dirt	For dark/white spot, size $\Phi$ is defined as $\Phi = \frac{(x+y)}{2}$ 	Minor																							
	1. <table border="1" style="width: 100%; border-collapse: collapse;"> <thead> <tr> <th rowspan="2">Zone Size(mm)</th> <th colspan="3">Acceptable Qty</th> </tr> <tr> <th>A</th> <th>B</th> <th>C</th> </tr> </thead> <tbody> <tr> <td><math>\Phi \leq 0.1</math></td> <td colspan="3" style="text-align: center;">Ignore</td> </tr> <tr> <td><math>0.10 &lt; \Phi \leq 0.15</math></td> <td colspan="3" style="text-align: center;">2</td> </tr> <tr> <td><math>0.15 &lt; \Phi \leq 0.20</math></td> <td colspan="3" style="text-align: center;">1</td> </tr> <tr> <td><math>0.20 &lt; \Phi</math></td> <td colspan="3" style="text-align: center;">0</td> </tr> </tbody> </table>	Zone Size(mm)		Acceptable Qty			A	B	C	$\Phi \leq 0.1$	Ignore			$0.10 < \Phi \leq 0.15$	2			$0.15 < \Phi \leq 0.20$	1			$0.20 < \Phi$	0			
Zone Size(mm)	Acceptable Qty																									
	A	B	C																							
$\Phi \leq 0.1$	Ignore																									
$0.10 < \Phi \leq 0.15$	2																									
$0.15 < \Phi \leq 0.20$	1																									
$0.20 < \Phi$	0																									
	<b>Clear Spots</b>  TP Dirt	2. <table border="1" style="width: 100%; border-collapse: collapse;"> <thead> <tr> <th rowspan="2">Zone Size(mm)</th> <th colspan="3">Acceptable Qty</th> </tr> <tr> <th>A</th> <th>B</th> <th>C</th> </tr> </thead> <tbody> <tr> <td><math>\Phi \leq 0.1</math></td> <td colspan="3" style="text-align: center;">Ignore</td> </tr> <tr> <td><math>0.10 &lt; \Phi \leq 0.15</math></td> <td colspan="3" style="text-align: center;">3</td> </tr> <tr> <td><math>0.15 &lt; \Phi \leq 0.25</math></td> <td colspan="3" style="text-align: center;">2</td> </tr> <tr> <td><math>0.25 &lt; \Phi</math></td> <td colspan="3" style="text-align: center;">0</td> </tr> </tbody> </table>	Zone Size(mm)	Acceptable Qty			A	B	C	$\Phi \leq 0.1$	Ignore			$0.10 < \Phi \leq 0.15$	3			$0.15 < \Phi \leq 0.25$	2			$0.25 < \Phi$	0			Minor
Zone Size(mm)	Acceptable Qty																									
	A	B	C																							
$\Phi \leq 0.1$	Ignore																									
$0.10 < \Phi \leq 0.15$	3																									
$0.15 < \Phi \leq 0.25$	2																									
$0.25 < \Phi$	0																									



<b>OUTGOING QUALITY STANDARD</b>	<b>PAGE 3 OF 7</b>
----------------------------------	--------------------

**TITLE: FUNCTIONAL TEST & INSPECTION CRITERIA**

	<b>Dim Spots</b>	3.	<table border="1" style="width:100%; border-collapse: collapse;"> <tr> <th style="text-align: center;">2. Zone Size(mm)</th> <th colspan="3" style="text-align: center;">Acceptable Qty</th> </tr> <tr> <th style="text-align: center;">Φ ≤ 0.2</th> <th style="text-align: center;">A</th> <th style="text-align: center;">B</th> <th style="text-align: center;">C</th> </tr> <tr> <td style="text-align: center;">0.20 &lt; Φ ≤ 0.40</td> <td colspan="3" style="text-align: center;">Ignore</td> </tr> <tr> <td style="text-align: center;">0.40 &lt; Φ ≤ 0.60</td> <td colspan="3" style="text-align: center;">2</td> </tr> <tr> <td style="text-align: center;">0.60 &lt; Φ</td> <td colspan="3" style="text-align: center;">1</td> </tr> <tr> <td style="text-align: center;">0.60 &lt; Φ</td> <td colspan="3" style="text-align: center;">0</td> </tr> </table>	2. Zone Size(mm)	Acceptable Qty			Φ ≤ 0.2	A	B	C	0.20 < Φ ≤ 0.40	Ignore			0.40 < Φ ≤ 0.60	2			0.60 < Φ	1			0.60 < Φ	0			Minor
2. Zone Size(mm)	Acceptable Qty																											
Φ ≤ 0.2	A	B	C																									
0.20 < Φ ≤ 0.40	Ignore																											
0.40 < Φ ≤ 0.60	2																											
0.60 < Φ	1																											
0.60 < Φ	0																											

**4.2 Cosmetic Defect**

Item No	Items to be inspected	Inspection Standard	Classification of defects																																			
4.2.2	<b>Line defect</b> Black line, White line, Foreign material on polarizer	<table border="1" style="width:100%; border-collapse: collapse;"> <tr> <th colspan="2" style="text-align: center;">size(mm)</th> <th colspan="3" style="text-align: center;">Acceptable Qty</th> </tr> <tr> <th style="text-align: center;">L(Length)</th> <th style="text-align: center;">W(Width)</th> <th colspan="3" style="text-align: center;">zone</th> </tr> <tr> <th style="text-align: center;">Ignore</th> <th style="text-align: center;">W ≤ 0.02</th> <th style="text-align: center;">A</th> <th style="text-align: center;">B</th> <th style="text-align: center;">C</th> </tr> <tr> <td style="text-align: center;">L ≤ 3.0</td> <td style="text-align: center;">0.02 &lt; W ≤ 0.03</td> <td colspan="3" style="text-align: center;">Ignore</td> </tr> <tr> <td style="text-align: center;">L ≤ 2.0</td> <td style="text-align: center;">0.03 &lt; W ≤ 0.05</td> <td colspan="3" style="text-align: center;">2</td> </tr> <tr> <td style="text-align: center;"></td> <td style="text-align: center;">0.05 &lt; W</td> <td colspan="3" style="text-align: center;">1</td> </tr> <tr> <td style="text-align: center;"></td> <td style="text-align: center;">0.05 &lt; W</td> <td colspan="3" style="text-align: center;">Define as spot defect</td> </tr> </table>	size(mm)		Acceptable Qty			L(Length)	W(Width)	zone			Ignore	W ≤ 0.02	A	B	C	L ≤ 3.0	0.02 < W ≤ 0.03	Ignore			L ≤ 2.0	0.03 < W ≤ 0.05	2				0.05 < W	1				0.05 < W	Define as spot defect			Minor
	size(mm)		Acceptable Qty																																			
L(Length)	W(Width)	zone																																				
Ignore	W ≤ 0.02	A	B	C																																		
L ≤ 3.0	0.02 < W ≤ 0.03	Ignore																																				
L ≤ 2.0	0.03 < W ≤ 0.05	2																																				
	0.05 < W	1																																				
	0.05 < W	Define as spot defect																																				
Foreign material on TP film	<p>The line can be seen after mobile phone in the operating condition:</p> <table border="1" style="width:100%; border-collapse: collapse;"> <tr> <th colspan="2" style="text-align: center;">size(mm)</th> <th colspan="3" style="text-align: center;">Acceptable Qty</th> </tr> <tr> <th style="text-align: center;">L(Length)</th> <th style="text-align: center;">W(Width)</th> <th colspan="3" style="text-align: center;">zone</th> </tr> <tr> <th style="text-align: center;">Ignore</th> <th style="text-align: center;">W ≤ 0.03</th> <th style="text-align: center;">A</th> <th style="text-align: center;">B</th> <th style="text-align: center;">C</th> </tr> <tr> <td style="text-align: center;">L ≤ 5.0</td> <td style="text-align: center;">0.03 &lt; W ≤ 0.05</td> <td colspan="3" style="text-align: center;">Ignore</td> </tr> <tr> <td style="text-align: center;"></td> <td style="text-align: center;">0.05 &lt; W</td> <td colspan="3" style="text-align: center;">3</td> </tr> <tr> <td style="text-align: center;"></td> <td style="text-align: center;">0.05 &lt; W</td> <td colspan="3" style="text-align: center;">Define as spot defect</td> </tr> </table>	size(mm)		Acceptable Qty			L(Length)	W(Width)	zone			Ignore	W ≤ 0.03	A	B	C	L ≤ 5.0	0.03 < W ≤ 0.05	Ignore				0.05 < W	3				0.05 < W	Define as spot defect									
size(mm)		Acceptable Qty																																				
L(Length)	W(Width)	zone																																				
Ignore	W ≤ 0.03	A	B	C																																		
L ≤ 5.0	0.03 < W ≤ 0.05	Ignore																																				
	0.05 < W	3																																				
	0.05 < W	Define as spot defect																																				
		<p>If the scratch can be seen after mobile phone cover assembling or in the operating condition, judge by the line defect of 4.2.2.</p> <p>If the scratch can be seen only in non-operating condition or some special angle, judge by the following.</p>																																				

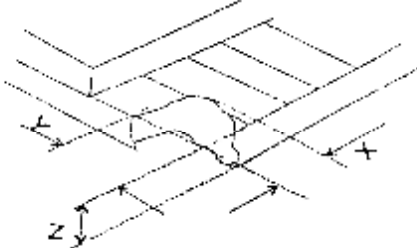



 OUTGOING QUALITY STANDARD		PAGE 4 OF 7									
TITLE:FUNCTIONAL TEST & INSPECTION CRITERIA											
4.2.3	<b>Dim line defect</b>  Polarizer scratch TP film scratch	Size(mm)		Acceptable Qty		Minor					
		L(Length)	W(Width)	Zone							
				A	B		C				
		Ignore	$W \leq 0.03$	Ignore			Ignore				
		$5.0 < L \leq 10.0$	$0.03 < W \leq 0.05$	2							
		$L \leq 5.0$	$0.05 < W \leq 0.08$	1							
	$0.08 < W$	0									
4.2.4	Polarize Air bubble	Air bubbles between glass & polarizer				Minor					
		2. Zone Size(mm)	Acceptable Qty								
			A	B	C						
		$\Phi \leq 0.2$	Ignore		Ignore						
		$0.20 < \Phi \leq 0.30$	2								
$0.30 < \Phi \leq 0.50$	1										
$0.50 < \Phi$	0										
<b>4.3. Cosmetic Defect</b>											
Item No	Items to be inspected	Inspection Standard			Classification of defects						
		(i) Chips on corner A:LCD Glass defect    <table border="1" data-bbox="518 1713 1149 1809"> <tr> <td>X</td> <td>Y</td> <td>Z</td> </tr> <tr> <td><math>\leq 2.0</math></td> <td><math>\leq S</math></td> <td>Disregard</td> </tr> </table> Notes: S=contact pad length Chips on the corner of terminal shall not be allowed to extend into the ITO pad or expose perimeter seal.			X	Y	Z	$\leq 2.0$	$\leq S$	Disregard	Minor
X	Y	Z									
$\leq 2.0$	$\leq S$	Disregard									



OUTGOING QUALITY STANDARD		PAGE 5 OF 7							
TITLE:FUNCTIONAL TEST & INSPECTION CRITERIA									
4.3.5	Glass defect	B:TP Glass defect <table border="1"> <thead> <tr> <th>X(mm)</th> <th>Y(mm)</th> <th>Z(mm)</th> </tr> </thead> <tbody> <tr> <td>≤3.0</td> <td>≤3.0</td> <td>Disregard</td> </tr> </tbody> </table>	X(mm)	Y(mm)	Z(mm)	≤3.0	≤3.0	Disregard	Minor
		X(mm)	Y(mm)	Z(mm)					
		≤3.0	≤3.0	Disregard					
(ii)Usual surface cracks A:LCD Glass defect <table border="1"> <thead> <tr> <th>X</th> <th>Y</th> <th>Z</th> </tr> </thead> <tbody> <tr> <td>≤3.0</td> <td>&lt;Inner border line of the seal</td> <td>Disregard</td> </tr> </tbody> </table>	X	Y	Z	≤3.0	<Inner border line of the seal	Disregard			
X	Y	Z							
≤3.0	<Inner border line of the seal	Disregard							
B:TP Glass defect <table border="1"> <thead> <tr> <th>X(mm)</th> <th>Y(mm)</th> <th>Z(mm)</th> </tr> </thead> <tbody> <tr> <td>≤6.0</td> <td>&lt;2.0</td> <td>Disregard</td> </tr> </tbody> </table>	X(mm)	Y(mm)	Z(mm)	≤6.0	<2.0	Disregard			
X(mm)	Y(mm)	Z(mm)							
≤6.0	<2.0	Disregard							
		(iii) Crack Cracks tend to break are not allowed. 	Major						

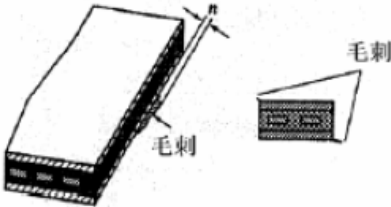

 OUTGOING QUALITY STANDARD	PAGE 6 OF 7		
TITLE:FUNCTIONAL TEST & INSPECTION CRITERIA			
<b>4.4 Parts Defect</b>			
Item No	Items to be inspected	Inspection Standard	Classification of defects
	4.4.1 Parts contraposition	1、 Not allow IC and FPC/heat-seal lead width is more than 50% beyond lead pattern. 2、 Not allow chip or solder component is off center more than 50% of the pad outline.	Major
	4.4.2 SMT	According to the <Acceptability of electronic assemblies> IPC-A-610C class 2 standard. Component missing or function defect are Major defect, the others are Minor defect.	

	<p>OUTGOING QUALITY STANDARD</p>	<p>PAGE 7 OF 7</p>
<p>TITLE: FUNCTIONAL TEST &amp; INSPECTION CRITERIA</p>		
<p>4.4.3 TP Defect</p>	<p>1、 Pattern font: Pattern fonts are clear and symmetrical, pattern fonts filter lightly are allowed; The fort line is not allow to thinner or thicker than 1/3of normal size, and swing is not more than 0.1mm. the line is smooth and not broken.</p>  <p>图案字体 Pattern font</p> <p>2、 The wing forward in the side of Visual Area: The length of wing forward inside of the Visual Area: <math>n \leq 0.2\text{mm}</math>; Not excess 3 point, and the distance <math>D \geq 20\text{mm}</math>.</p>  <p>3、 Film impression:With operation, must be invisibility.</p> <p>4、 Touch panel knob: if writing function normally,it could be allowed.</p>  <p>TP鼓 TP knob</p> <p>5、 Newton ring Without operation, the color circle of Regularity or Non-regularity from the normal or slope angle of view.</p> <p>1、 <b>Regularity:</b> The area of the newton ring is less than 1/3 area of the touch panel; and no character affected and line distorted after touch panel lightening. It's ok.</p> <p>2、 <b>Non-regularity :</b> The area of the Newton ring is less than the 1/2 area of touch panel with lightening. And no character affected and line</p>  <p>规律形</p>  <p>非规律形</p>	<p>Minor</p>

## ■ PRECAUTIONS FOR USING LCD MODULES

### Handing Precautions

(1) The display panel is made of glass and polarizer. As glass is fragile. It tends to become or chipped during handling especially on the edges. Please avoid dropping or jarring. Do not subject it to a mechanical shock by dropping it or impact.

(2) If the display panel is damaged and the liquid crystal substance leaks out, be sure not to get any in your mouth. If the substance contacts your skin or clothes, wash it off using soap and water.

(3) Do not apply excessive force to the display surface or the adjoining areas since this may cause the color tone to vary. Do not touch the display with bare hands. This will stain the display area and degraded insulation between terminals (some cosmetics are determined to the polarizer).

(4) The polarizer covering the display surface of the LCD module is soft and easily scratched. Handle this polarizer carefully. Do not touch, push or rub the exposed polarizers with anything harder than an HB pencil lead (glass, tweezers, etc.). Do not put or attach anything on the display area to avoid leaving marks on. Condensation on the surface and contact with terminals due to cold will damage, stain or dirty the polarizer. After products are tested at low temperature they must be warmed up in a container before coming is contacting with room temperature air.

(5) If the display surface becomes contaminated, breathe on the surface and gently wipe it with a soft dry cloth. If it is heavily contaminated, moisten cloth with one of the following solvents

- Isopropyl alcohol
- Ethyl alcohol

Do not scrub hard to avoid damaging the display surface.

(6) Solvents other than those above-mentioned may damage the polarizer. Especially, do not use the following.

- Water
- Ketone
- Aromatic solvents

Wipe off saliva or water drops immediately, contact with water over a long period of time may cause deformation or color fading. Avoid contacting oil and fats.

(7) Exercise care to minimize corrosion of the electrode. Corrosion of the electrodes is accelerated by water droplets, moisture condensation or a current flow in a high-humidity environment.

(8) Install the LCD Module by using the mounting holes. When mounting the LCD module make sure it is free of twisting, warping and distortion. In particular, do not forcibly pull or bend the I/O cable or the backlight cable.

(9) Do not attempt to disassemble or process the LCD module.

(10) NC terminal should be open. Do not connect anything.

(11) If the logic circuit power is off, do not apply the input signals.

(12) Electro-Static Discharge Control, Since this module uses a CMOS LSI, the same careful attention should be paid to electrostatic discharge as for an ordinary CMOS IC. To prevent destruction of the elements by static electricity, be careful to maintain an optimum work environment.

- Before remove LCM from its packing case or incorporating it into a set, be sure the module and your body have the same electric potential. Be sure to ground the body when handling the LCD modules.

- Tools required for assembling, such as soldering irons, must be properly grounded. make certain the AC power source for the soldering iron does not leak. When using an electric screwdriver to attach LCM, the screwdriver should be of ground potentiality to minimize as much as possible any transmission of electromagnetic waves produced sparks coming from the commutator of the motor.

- To reduce the amount of static electricity generated, do not conduct assembling and other work under dry conditions. To reduce the generation of static electricity be careful that the air in the work is not too dried. A relative humidity of 50%-60% is recommended. As far as possible make the electric potential of your work clothes and that of the work bench the ground potential

- The LCD module is coated with a film to protect the display surface. Exercise care when peeling off this protective film since static electricity may be generated

(13) Since LCM has been assembled and adjusted with a high degree of precision, avoid applying excessive shocks to the module or making any alterations or modifications to it.

- Do not alter, modify or change the shape of the tab on the metal frame.  
- Do not make extra holes on the printed circuit board, modify its shape or change the positions of components to be attached.

- Do not damage or modify the pattern writing on the printed circuit board.

- Absolutely do not modify the zebra rubber strip (conductive rubber) or heat seal connector.

- Except for soldering the interface, do not make any alterations or modifications with a soldering iron.

- Do not drop, bend or twist LCM.

### Handling precaution for LCM

LCM is easy to be damaged. Please note below and be careful for handling.

#### Correct handling:



As above picture, please handle with anti-static gloves around LCM edges.

#### Incorrect handling:



Please don't touch IC directly.

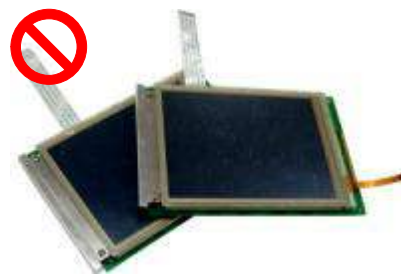

Please don't stack LCM.



Please don't hold the surface of panel.

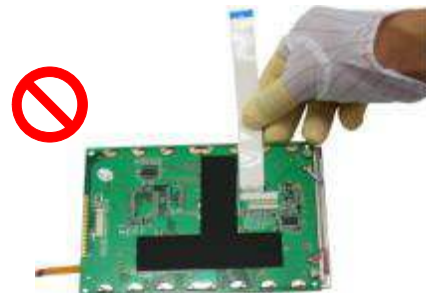

Please don't stretch interface of output, such as FPC cable.



Please don't hold the surface of IC.



Please don't operate with sharp stick such as pens.

**Storage Precautions**

When storing the LCD modules, the following precaution is necessary.

- (1) Store them in a sealed polyethylene bag. If properly sealed, there is no need for the desiccant.
- (2) Store them in a dark place. Do not expose to sunlight or fluorescent light, keep the temperature between 0°C and 35°C, and keep the relative humidity between 40%RH and 60%RH.
- (3) The polarizer surface should not come in contact with any other objects. (We advise you to store them in the anti-static electricity container in which they were shipped.)

**Others**

Liquid crystals solidify under low temperature (below the storage temperature range) leading to defective orientation or the generation of air bubbles (black or white). Air bubbles may also be generated if the module is subject to a low temperature.

If the LCD modules have been operating for a long time showing the same display patterns, the display patterns may remain on the screen as ghost images and a slight contrast irregularity may also appear. A normal operating status can be regained by suspending use for some time. It should be noted that this phenomenon does not adversely affect performance reliability.

To minimize the performance degradation of the LCD modules resulting from destruction caused by static electricity etc., exercise care to avoid holding the following sections when handling the modules.

- Exposed area of the printed circuit board.
- Terminal electrode sections.

**■ USING LCD MODULES**

**Installing LCD Modules**

The hole in the printed circuit board is used to fix LCM as shown in the picture below. Attend to the following items when installing the LCM.

- (1) Cover the surface with a transparent protective plate to protect the polarizer and LC cell.

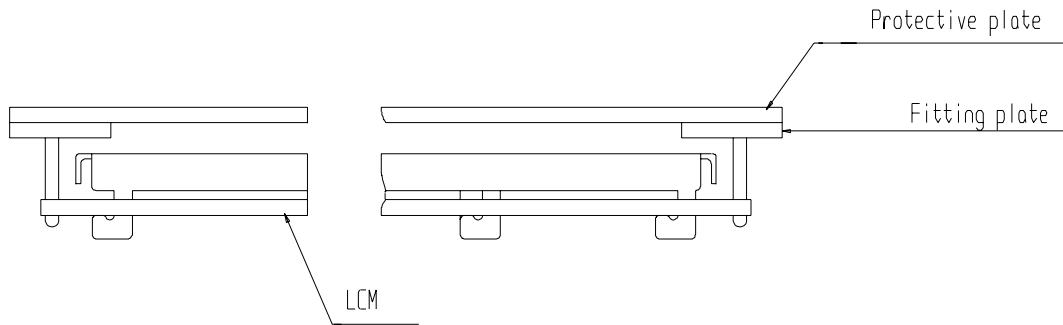

- (2) When assembling the LCM into other equipment, the spacer to the bit between the LCM and the fitting plate should have enough height to avoid causing stress to the module surface, refer to the individual specifications for measurements. The measurement tolerance should be  $\pm 0.1$ mm.

**Precaution for assemble the module with BTB connector:**

Please note the position of the male and female connector position, don't assemble or assemble like the method which the following picture shows

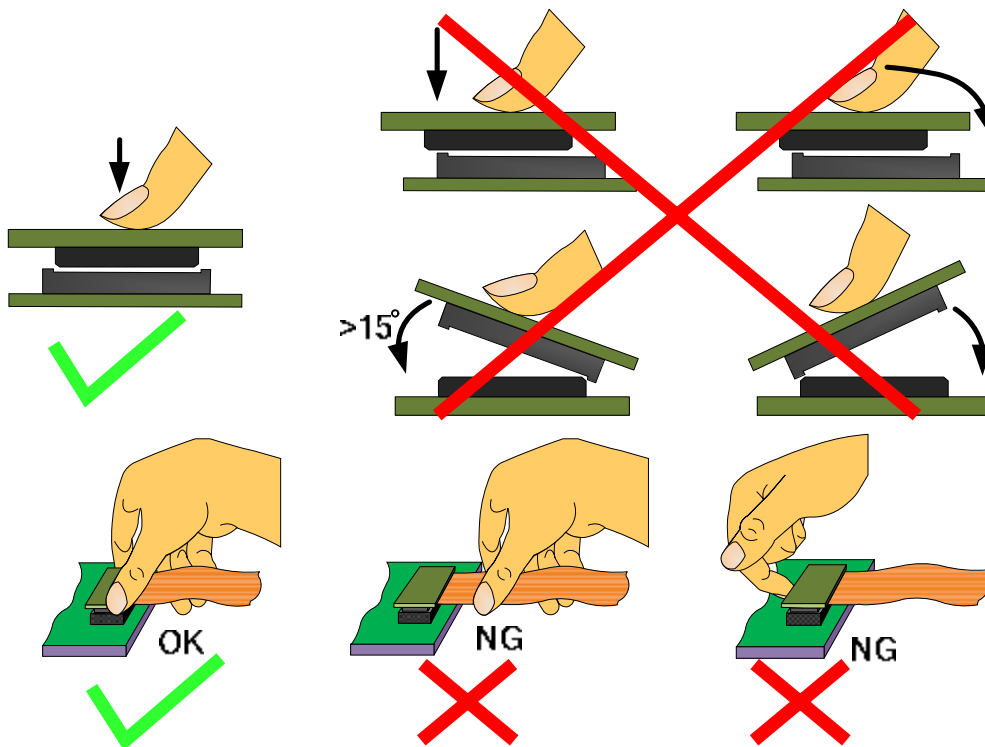

**Precaution for soldering the LCM**

	<b>Manual soldering</b>	<b>Machine drag soldering</b>	<b>Machine press soldering</b>
<b>No RoHS product</b>	290°C ~350°C. Time : 3-5S.	330°C ~350°C. Speed : 4-8 mm/s.	300°C ~330°C. Time : 3-6S. Press: 0.8~1.2Mpa
<b>RoHS product</b>	340°C ~370°C. Time : 3-5S.	350°C ~370°C. Time : 4-8 mm/s.	330°C ~360°C. Time : 3-6S. Press: 0.8~1.2Mpa



(1) If soldering flux is used, be sure to remove any remaining flux after finishing to soldering operation. (This does not apply in the case of a non-halogen type of flux.) It is recommended that you protect the LCD surface with a cover during soldering to prevent any damage due to flux spatters.

(2) When soldering the electroluminescent panel and PC board, the panel and board should not be detached more than three times. This maximum number is determined by the temperature and time conditions mentioned above, though there may be some variance depending on the temperature of the soldering iron.

(3) When remove the electroluminescent panel from the PC board, be sure the solder has completely melted, the soldered pad on the PC board could be damaged.

#### **Precautions for Operation**

(1) Viewing angle varies with the change of liquid crystal driving voltage (VLCD). Adjust VLCD to show the best contrast.

(2) It is an indispensable condition to drive LCD's within the specified voltage limit since the higher voltage then the limit cause the shorter LCD life. An electrochemical reaction due to direct current causes LCD's undesirable deterioration, so that the use of direct current drive should be avoided.

(3) Response time will be extremely delayed at lower temperature than the operating temperature range and on the other hand at higher temperature LCD's show dark color in them. However those phenomena do not mean malfunction or out of order with LCD's, Which will come back in the specified operating temperature.

(4) If the display area is pushed hard during operation, the display will become abnormal. However, it will return to normal if it is turned off and then back on.

(5) A slight dew depositing on terminals is a cause for electro-chemical reaction resulting in terminal open circuit. Usage under the maximum operating temperature, 50%RH or less is required.

(6) Input logic voltage before apply analog high voltage such as LCD driving voltage when power on. Remove analog high voltage before logic voltage when power off the module. Input each signal after the positive/negative voltage becomes stable.

(7) Please keep the temperature within specified range for use and storage. Polarization degradation, bubble generation or polarizer peel-off may occur with high temperature and high humidity.



**Safety**

(1) It is recommended to crush damaged or unnecessary LCDs into pieces and wash them off with solvents such as acetone and ethanol, which should later be burned.

(2) If any liquid leaks out of a damaged glass cell and comes in contact with the hands, wash off thoroughly with soap and water.

**Limited Warranty**

Unless agreed between Multi-Inno and customer, Multi-Inno will replace or repair any of its LCD modules which are found to be functionally defective when inspected in accordance with Multi-Inno LCD acceptance standards (copies available upon request) for a period of one year from date of production. Cosmetic/visual defects must be returned to Multi-Inno within 90 days of shipment. Confirmation of such date shall be based on data code on product. The warranty liability of Multi-Inno limited to repair and/or replacement on the terms set forth above. Multi-Inno will not be responsible for any subsequent or consequential events.

**Return LCM under warranty**

No warranty can be granted if the precautions stated above have been disregarded. The typical examples of violations are :

- Broken LCD glass.
- PCB eyelet is damaged or modified.
- PCB conductors damaged.
- Circuit modified in any way, including addition of components.
- PCB tampered with by grinding, engraving or painting varnish.
- Soldering to or modifying the bezel in any manner.

Module repairs will be invoiced to the customer upon mutual agreement. Modules must be returned with sufficient description of the failures or defects. Any connectors or cable installed by the customer must be removed completely without damaging the PCB eyelet, conductors and terminals.

**■ PRIOR CONSULT MATTER**

- 1.①For Multi-Inno standard products, we keep the right to change material, process ... for improving the product property without notice on our customer.
- ②For OEM products, if any change needed which may affect the product property, we will consult with our customer in advance.
2. If you have special requirement about reliability condition, please let us know before you start the test on our samples.