

PART NUMBER	REV	FIRST USED
567450-1	C	854400-1
567450-2	C	565435-5

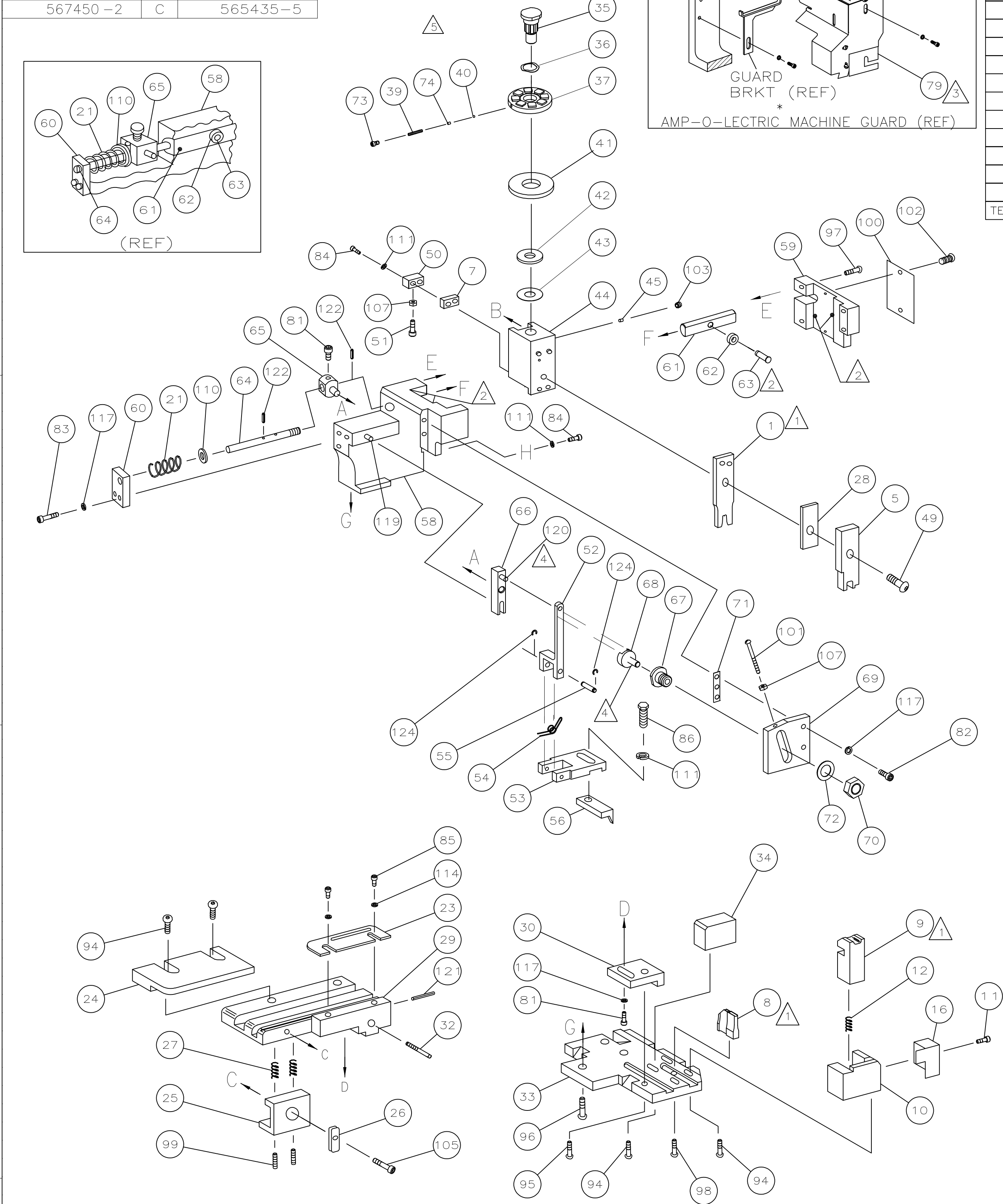
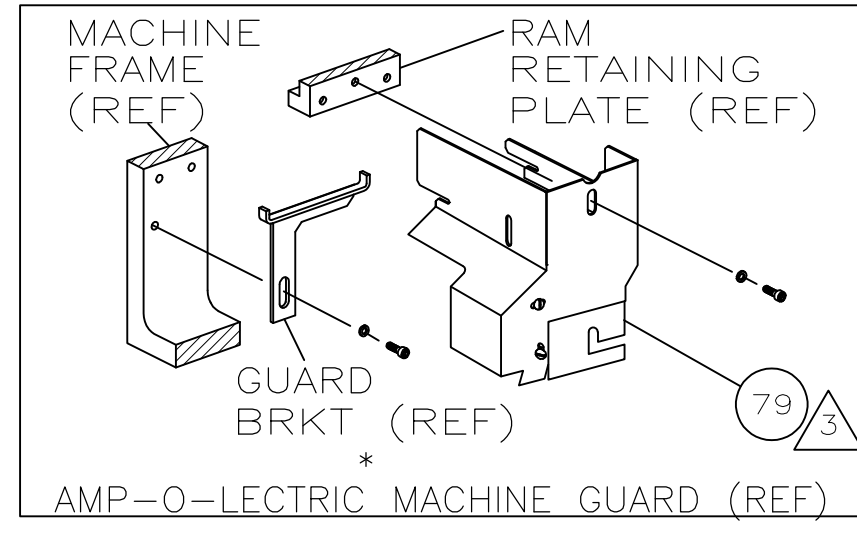
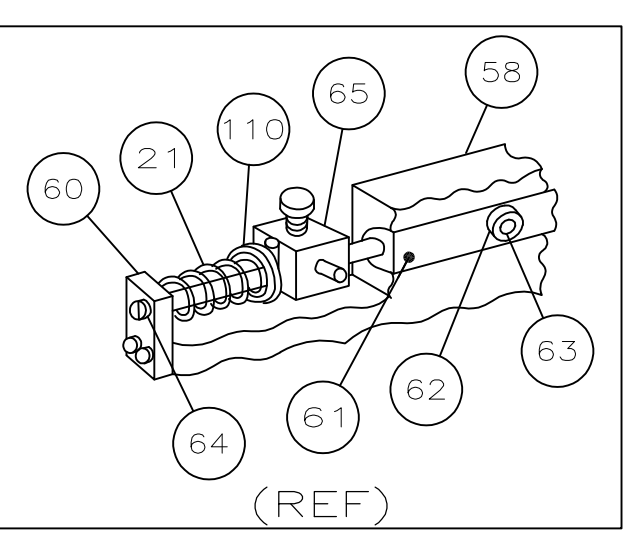

TERMINAL NAME: FUEL TANK SENDER BUS 346453-1

PAD LTR	CRIMP HEIGHT	WIRE SIZE	
A	.058 ±.002	20	
B	.054 ±.002	22	
C	NOT	USED	
D	NOT	USED	
CRIMP	SIZE	TYPE	RANGE
WIRE	.090	F	22-20
INSUL	-	-	-
FEED	APPL INST	SET UP GAGE	LAYOUT
.561	Δ18040	458637-1	L1452
WIRE STRIP LENGTH			
-1	LEADMAKER	MECH-POST FEED	
-2	AMP-O-LECTRIC	MECH-PRE FEED	

CRIMPING DATA

PAD LTR	CRIMP HEIGHT	WIRE SIZE	
A	.058 ±.002	20	
B	.054 ±.002	22	
C	NOT	USED	
D	NOT	USED	
CRIMP	SIZE	TYPE	RANGE
WIRE	.090	F	22-20
INSUL	-	-	-
FEED	APPL INST	SET UP GAGE	LAYOUT
.561	Δ18040	458637-1	L1452
WIRE STRIP LENGTH			
-1	LEADMAKER	MECH-POST FEED	
-2	AMP-O-LECTRIC	MECH-PRE FEED	

LOC A DIST 66

REV	DESCRIPTION	DATE	DRN	APVD
C	ECR-07-015610	6-2007	MY	GB

QTY	REQD	PER	ASSY	PART NO	DESCRIPTION	ITEM NO
1	1	-		21045-3	RING,RET "C"(Ø.187)FD FING PIN	124
2	2	-		5-21028-1	PIN,SLT SPR(Ø.125x.50)ADJ ROD	122
1	1	-		4-21028-0	PIN,SLT SPR(Ø.093x.75)ST GDE PL	121
1	1	-		1-21030-1	PIN,DOWEL(Ø.187x.50)LEVER	120
1	1	-		1-21030-6	PIN,DOWEL(Ø.187x1.25)HOUSING	119
5	5	-		21024-5	WASHER, LOCK(#10)ADJ BLOCK	117
2	2	-		21024-2	WASHER,LOCK(#4)FRONT STP GUIDE	114
4	4	-		21024-4	WASHER,LOCK(#8)STRIPPER	111
1	1	-		21899-4	WASHER,FLAT(Ø5/16)SCREW ADJ	110
2	2	-		21018-5	NUT,HEX(6-32)FEED ADJ	107
1	1	-		22353-8	SCR,SKT(Ø.187x.25)DRAG LEVER	105
1	1	-		21009-2	SCR,SKT SET(1/4-20x.25 LW)RAM	103
2	2	-		21017-2	SCR,DRIVE(#2x.19)ID PLATE	102
1	1	-		6-23715-5	SCR,PAN HD(6-32x1.50)FEED ADJ	101
1	1	-		461264-1	PLATE, IDENTIFICATION	100
2	2	-		5-21006-6	SCR,SET(10-32x.75)DRAG	99
1	1	-		22733-8	SCR,BHC(8-32x.38 LW)ANVIL	98
4	4	-		2-21002-9	SCR,BHC(10-32x.75)	97
3	3	-		2-22733-8	SCR,BHC(1/4-20x.62)HOUSING	96
1	1	-		2-21002-7	SCR,BHC(10-32x.50)SG ADJ BLOCK	95
6	6	-		2-21002-2	SCR,BHC(8-32x.50)SHEAR	94
1	1	-		1-21002-7	SCR,BHC(6-32x.38)CAM	91
1	1	-		2-22603-0	SCR,HEX HD(8-32x.31)FEED FINGER	86
2	2	-		1-21000-3	SCR,SHC(4-40x.25)F ST GUIDE	85
3	3	-		2-21000-7	SCR,SHC(8-32x.50)STRIPPER	84
2	2	-		3-21000-7	SCR,SHC(10-32x.75)FEED ROD GD	83
2	2	-		3-21000-6	SCR,SHC(10-32x.62)FEED ADJ BLK	82
2	2	-		3-21000-4	SCR,SHC(10-32x.38)SG ADJ BL	81
REF	-	-		455749-1	GUARD, WINDOW	79
1	1	-		690603-1	SPRING, ASSIST	74
1	1	-		23030-1	SCR,SHC(6-32x.25)CP DISC	73
1	1	-		458109-1	WASHER, SPECIAL	72
1	1	-		690517-1	SPACER	71
-2	-1	U/M				

QTY	REQD	PER	ASSY	PART NO	DESCRIPTION	ITEM NO
1	1	-		22594-8	NUT,HEX(1/2-20)	70
1	1	-		240628-1	PLATE, ADJUSTMENT	69
1	1	-		240626-1	SHAFT, PIVOT	68
1	1	-		240633-1	BUSHING	67
1	1	-		455680-1	LEVER, INTERMEDIATE	66
1	1	-		240629-1	BLOCK, PIVOT	65
1	1	-		240632-2	SCREW, ADJ FEED ROD	64
1	1	-		240659-3	PIN, CAM ROLLER	63
1	1	-		240658-1	ROLLER, CAM	62
1	1	-		454398-2	ROD, FEED	61
1	1	-		454178-1	GUIDE, FEED ROD	60
1	1	-		454220-1	CAP, RAM	59
1	1	-		454485-1	HOUSING	58
1	1	-		458537-2	PAWL, FEED	56
1	1	-		240624-1	PIN, FEED FINGER	55
1	1	-		691499-1	SPRING, FEED FINGER	54
1	1	-		690541-1	HOLDER, FEED FINGER	53
1	1	-		455679-1	LEVER, TERMINAL FEED ARM	52
1	1	-		811242-2	BUMPER, HOLDDOWN	51
1	1	-		690753-1	SPACER, TONKER	50
1	1	-		7-21002-9	BOLT, CRIMPER(5/16x1.00)	49
1	-	-		690602-5	CAM, PRE-FEED 1 1/8 ST	48
-	1	-		690501-4	CAM, POST-FEED 1 5/8 ST	47
1	1	-		690191-1	PLUG, NYLON	45
1	1	-		455673-1	RAM	44
1	1	-		690125-1	WASHER, LAMINATED	43
1	1	-		690124-1	WASHER, RAM	42
1	1	-		690223-1	DISC, SPACER	41
1	1	-		23241-6	BALL, STEEL	40
1	1	-		690170-1	SPRING, COMPRESSION	39
1	1	-		690141-7	DISC, WIRE	37
1	1	-		22480-5	WASHER, SPRING	36
1	1	-		690212-1	POST, RAM	35
1	1	-		2-690786-0	SUPPORT, TERMINAL	34
1	1	-		455675-1	PLATE, BASE	33
1	1	-		690432-3	SCREW, ADJUSTMENT	32
1	1	-		455689-2	BLOCK, STRIP GUIDE ADJ	30
1	1	-		768785-1	PLATE, STRIP GUIDE	29
1	1	-		455888-4	SPACER, FRONT SHEAR DEP	28
2	2	-		1-22284-0	SPRING, DRAG	27
1	1	-		240793-1	LEVER, DRAG RELEASE	26
1	1	-		240792-1	DRAG, TERMINAL	25
1	1	-		7-690440-1	GUIDE, STRIP (REAR)	24
1	1	-		690438-1	GUIDE, STRIP (FRONT)	23
-	1	-		690472-2	STRIPPER	22
1	1	-		4-22284-9	SPRING, FEED RETURN	21
1	-	-		691353-1	STRIPPER	19
1	1	-		691667-1	GUARD, CHIP (FRONT)	16
1	1	-		3-22280-3	SPRING, SHEAR	12
1	1	-		690461-1	STOP, SHEAR	11
1	1	-		690459-1	HOLDER, SHEAR (FRONT)	10
1	1	-		454276-1	SHEAR, FLOAT (FRONT)	9
1	1	-		610196-8	ANVIL	8
1	1	-		3-240641-8	SPACER, DEPRESSOR (REAR)	7
1	1	-		1-455889-4	DEPRESSOR, SHEAR (FRONT)	5
1	1	-		4-456406-6	CRIMPER, WIRE	1

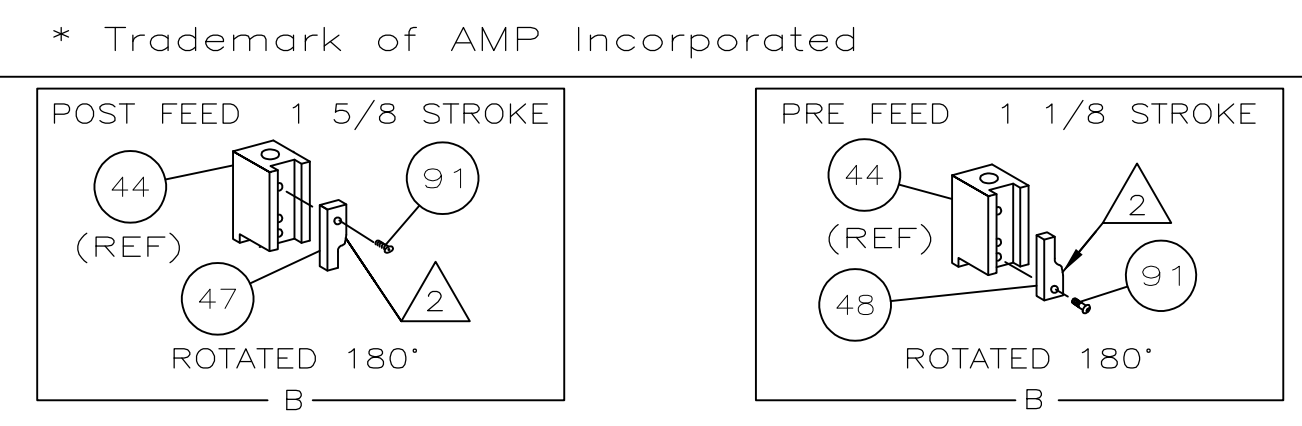

- 1 RECOMMENDED SPARE PARTS.
- 2 GREASE LIGHTLY.
- 3 GUARD MUST BE IN PLACE WHEN OPERATING APPLICATOR IN AMP-O-LECTRIC MACHINE.
- 4 LUBRICATE DAILY USING NO. 20 MACHINE OIL.
- 5 WHEN USED IN K40 LEADMAKING MACHINE USE FEED SIDE ONLY.

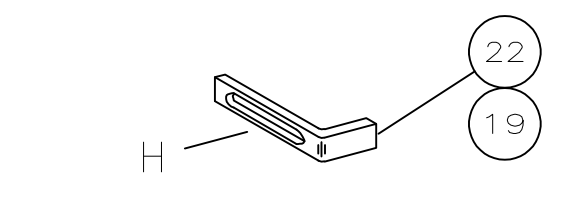

THIS DRAWING IS A CONTROLLED DOCUMENT.

DMN P. MATHIAS 5/19/92

Chk -

APVD -

NAME -

PRODUCT SPEC -

APPLICATION SPEC -

SIZE -

WEIGHT -

CAGE CODE -

DRAWING NO -

RESTRICTED TO -

SCALE -

SHEET 1 of 1

REV C

Tyco Electronics Corporation  
Harrisburg, PA 17105-3608

SIDE FEED HDM APPLICATOR

00779 ©=567450