



# PCA9618

Single channel Fm+ I<sup>2</sup>C-bus repeater

Rev. 1 — 13 January 2016

Product data sheet

## 1. General description

The PCA9618 is a CMOS integrated circuit that provides Fast-mode Plus (Fm+) I<sup>2</sup>C-bus or SMBus buffering of either the SCL or SDA line or can be used in any single bit applications that require buffering. While retaining all the operating modes and features of the I<sup>2</sup>C-bus system, it also permits extension of the I<sup>2</sup>C-bus by providing bidirectional buffering, thus enabling buses of 540 pF at 1 MHz or up to 4000 pF at lower speeds. Using the PCA9618 enables the system designer to isolate two halves of a bus for capacitance. The DATAA and DATAB pins are overvoltage tolerant and are high-impedance when the PCA9618 is unpowered.

The PCA9618 can be used to delay the SDA path by at least the minimum propagation delay, thereby providing an effective data hold time for applications that require an SDA hold time with respect to SCL. The PCA9618 includes an internal glitch filter, so that it will ignore glitches rather than expand them, this also means that the minimum propagation delay is on the order of 46 ns and is reasonably stable over temperature and supply voltage. Although this is not sufficient to provide the SDA delay requirement of the SMBus hold time specification of 300 ns, many parts that cannot be used with the 0 ns hold time of the I<sup>2</sup>C-bus specification only require a few ns of hold time to work correctly in a system. For these applications, the PCA9618 is an effective solution.

The PCA9618 can also be used as a buffer on a 1-wire bus similar to how the PCA9617A is used for the I<sup>2</sup>C-bus or to buffer the master (microcontroller's I/O) if the master's output is not strong enough to drive the 1-wire bus.

The 2.2 V to 5.5 V bus port B driver has the static level offset, while the port A driver eliminates the static offset voltage. This results in a LOW on the port B translating into a nearly 0 V LOW on the port A. This static offset voltage prevents the PCA9618 from latching into a steady state LOW when driven LOW.

The static offset design of the port B PCA9618 I/O driver prevents it from being connected to the static or incremented offset sides of other bus buffers. Port A of two or more PCA9618s can be connected together, also, to allow a star topography with port A on the common bus. Port A can be connected directly to any other buffer with static or incremented offset outputs. Multiple PCA9618s can be connected in series, port A to port B, with no build-up in offset voltage with only time of flight delays to consider.

The output pull-down on the port B internal buffer LOW is set for approximately 0.55 V, while the input threshold of the internal buffer is set about 90 mV lower (0.45 V). When the port B I/O is driven LOW internally, the LOW is not recognized as a LOW by the input. This prevents a latching condition from occurring. The output pull-down on port A drives a hard LOW and the input level is set at 0.35V<sub>CC</sub>.



## 2. Features and benefits

- 1 channel, bidirectional buffer isolates capacitance and allows 540 pF on either side of the device at 1 MHz and up to 4000 pF at lower speeds
- Operating supply voltage range of 2.2 V to 5.5 V
- Data pins are 5 V tolerant, allowing voltage translation applications
- 0 Hz to 1000 kHz clock frequency (the maximum system operating frequency may be less than 1000 kHz because of the delays added by the repeater)
- Open-drain input/outputs
- Latching free operation
- Accommodates Standard-mode, Fast-mode and Fast-mode Plus I<sup>2</sup>C-bus devices, SMBus (standard and high power mode), PMBus and multiple masters
- Powered-off high-impedance I<sup>2</sup>C-bus pins
- ESD protection exceeds 5500 V HBM per JESD22-A114 and 1000 V CDM per JESD22-C101
- Latch-up testing is done to JEDEC Standard JESD78 which exceeds 100 mA
- Packages offered: WLCSP4

## 3. Ordering information

Table 1. Ordering information

| Type number | Topside marking   | Package |   |           |
|-------------|-------------------|---------|---|-----------|
|             |                   | Name    | Description   | Version   |
| PCA9618UK   | •8 <sup>[1]</sup> | WLCSP4  | wafer level chip-scale package; 4 bumps; body 0.78 × 0.83 × 0.53 mm | PCA9618UK |

[1] Line A marking includes dot as pin 1 indication.

### 3.1 Ordering options

Table 2. Ordering options

| Type number | Orderable part number | Package | Packing method                                 | Minimum order quantity | Temperature range                   |
|-------------|-----------------------|---------|--|------------------------|-------------------------------------|
| PCA9618UK   | PCA9618UKZ            | WLCSP4  | Reel 13" Q1/T1<br>*Special mark chips dry pack | 10000                  | T <sub>amb</sub> = -40 °C to +85 °C |

## 4. Functional diagram

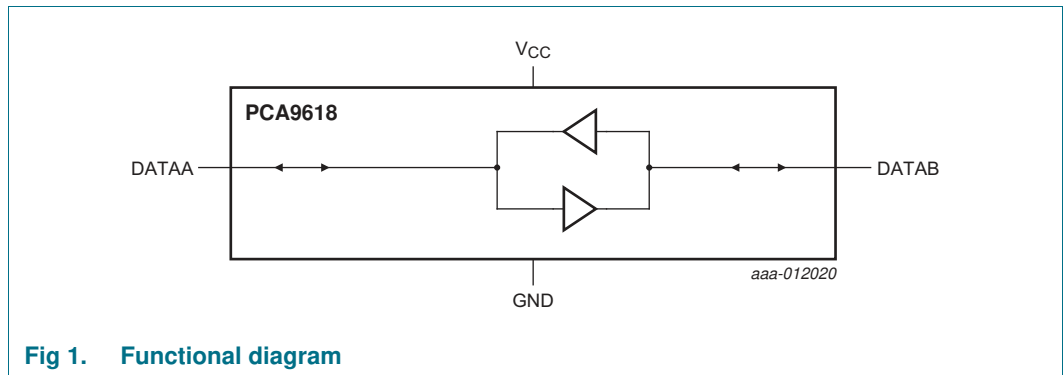

Fig 1. Functional diagram

## 5. Pinning information

### 5.1 Pinning

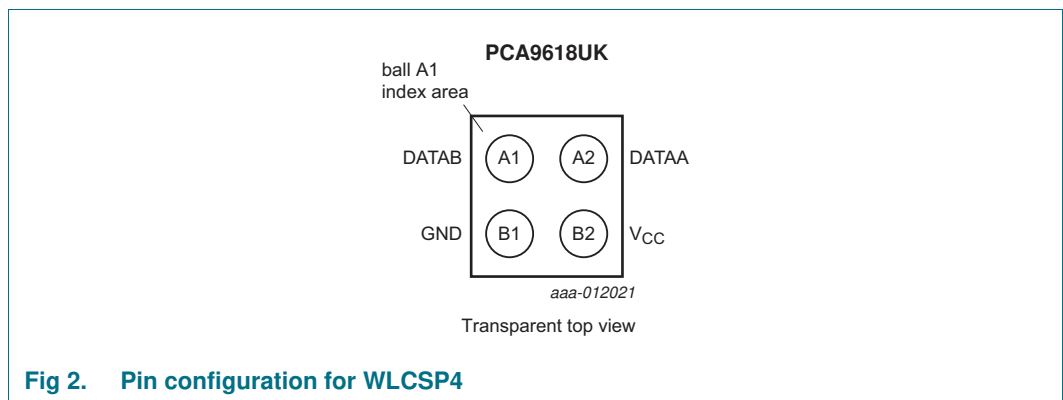

Fig 2. Pin configuration for WLCSP4

### 5.2 Pin description

Table 3. Pin description

| Symbol          | Pin    | Description                                  |
|-----------------|--------|--|
|                 | WLCSP4 |  |
| DATAA           | A2     | data line, A port with normal voltage levels |
| n.c.            | -      | not connected                                |
| V <sub>CC</sub> | B2     | port B supply voltage (2.2 V to 5.5 V)       |
| GND             | B1     | supply ground (0 V)                          |
| DATAB           | A1     | data line, B port with offset voltage levels |

## 6. Functional description

Refer to [Figure 1 “Functional diagram”](#).

All inputs and I/Os are overvoltage tolerant to 5.5 V even when the device is unpowered ( $V_{CC} = 0$  V). The PCA9618 includes a power-up circuit that keeps the output drivers turned off until  $V_{CC}$  is above 2.2 V and until after the internal reference circuits have settled  $\sim 400$   $\mu$ s. A LOW level on port A (below  $0.3V_{CC}$ ) turns on the port B driver and drives port B down to about 0.55 V. When port A rises above  $0.3V_{CC}$ , the port B pull-down driver is turned off and the external pull-up resistor pulls the pin HIGH. When port B falls first and goes below 0.4 V, the port A driver is turned on and port A pulls down to  $\sim 0$  V. The port A pull-down is not enabled unless the port B voltage goes below 0.4 V. If the port B low voltage goes below 0.4 V, the port B pull-down driver is enabled and port B will only be able to rise to 0.55 V until port A rises above  $0.3V_{CC}$ , then port B will continue to rise being pulled up by the external pull-up resistor. The  $V_{CC}$  supply is used to provide the  $0.35V_{CC}$  reference to the port A input comparators and for the power good detect circuit.

### 6.1 I<sup>2</sup>C-bus systems

As with the standard I<sup>2</sup>C-bus system, pull-up resistors are required to provide the logic HIGH levels on the buffered bus (standard open-collector configuration of the I<sup>2</sup>C-bus). The size of these pull-up resistors depends on the system, but each side of the repeater must have a pull-up resistor. This part designed to work with Standard mode, Fast-mode and Fast-mode Plus I<sup>2</sup>C-bus devices in addition to SMBus devices. Standard mode and Fast-mode I<sup>2</sup>C-bus devices only specify 3 mA output drive; this limits the termination current to 3 mA in a generic I<sup>2</sup>C-bus system where Standard-mode devices, Fast-mode devices and multiple masters are possible. When only Fast-mode Plus devices are used with 30 mA at 5 V drive strength, then lower value pull-up resistors can be used. The B-side RC should not be less than 67.5 ns because shorter RCs increase the turnaround bounce when the B-side transitions from being externally driven to pulled down by its offset buffer.

Please see Application Note *AN255, “I<sup>2</sup>C/SMBus Repeaters, Hubs and Expanders”* for additional information on sizing resistors and precautions when using more than one PCA9618 in a system or using the PCA9618 in conjunction with other bus buffers.

## 7. Application design-in information

A typical application is shown in [Figure 3](#). In this example, the system master and slave are running on a 3.3 V I<sup>2</sup>C-bus. Both buses run at 1000 kHz. Master devices can be placed on either bus.

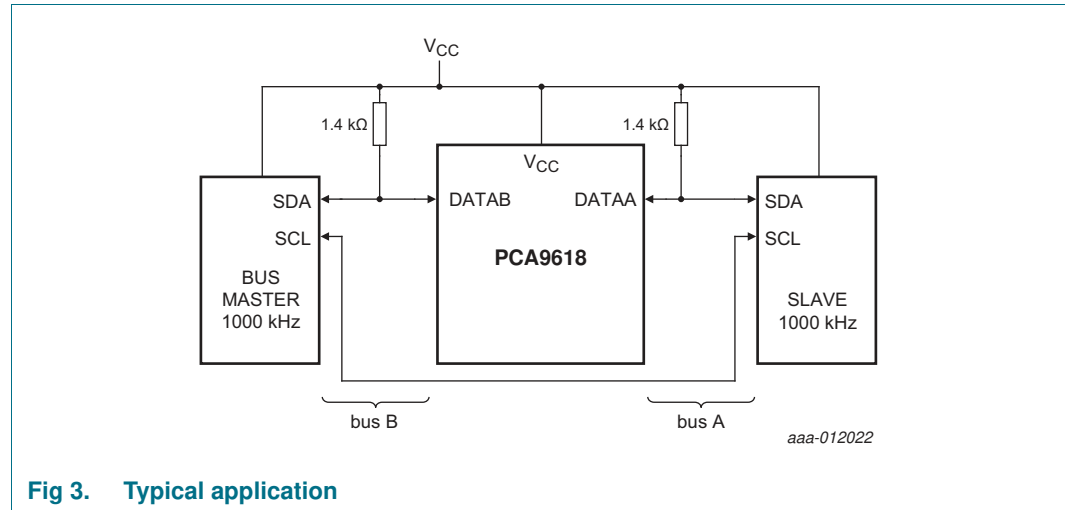

**Fig 3. Typical application**

When port A of the PCA9618 is pulled LOW by a driver on the I<sup>2</sup>C-bus, a comparator detects the falling edge when it goes below  $0.3V_{CC}$  and causes the internal driver on port B to turn on, causing port B to pull down to about 0.5 V. When port B of the PCA9618 falls, first comparator detects the falling edge when it goes below 0.4 V and causes the internal driver on port A to turn on and pull the port A pin down to ground. In order to illustrate what would be seen in a typical application, refer to [Figure 7](#) and [Figure 8](#). If the bus master in [Figure 3](#) were to write to the slave through the PCA9618, waveforms shown in [Figure 7](#) would be observed on the A bus. This looks like a normal I<sup>2</sup>C-bus transmission except that the turn on and turn off of the acknowledge signals are slightly delayed.

On the B bus side of the PCA9618, the data line would have a positive offset from ground equal to the  $V_{OL}$  of the PCA9618. After the eighth clock pulse, the data line will be pulled to the  $V_{OL}$  of the slave device which is very close to ground in this example. At the end of the acknowledge, the level rises only to the LOW level set by the driver in the PCA9618 for a short delay while the A bus side rises above  $0.3V_{CC}$  then it continues HIGH. It is important to note that any arbitration or clock stretching events require that the LOW level on the B bus side at the input of the PCA9618 ( $V_{IL}$ ) be at or below 0.4 V to be recognized by the PCA9618 and then transmitted to the A bus side.

Multiple PCA9618 port A sides can be connected in a star configuration ([Figure 4](#)), allowing all nodes to communicate with each other.

Multiple PCA9618s can be connected in series ([Figure 5](#)) as long as port A is connected to port B. I<sup>2</sup>C-bus slave devices can be connected to any of the bus segments. The number of devices that can be connected in series is limited by repeater delay/time-of-flight considerations on the maximum bus speed requirements.

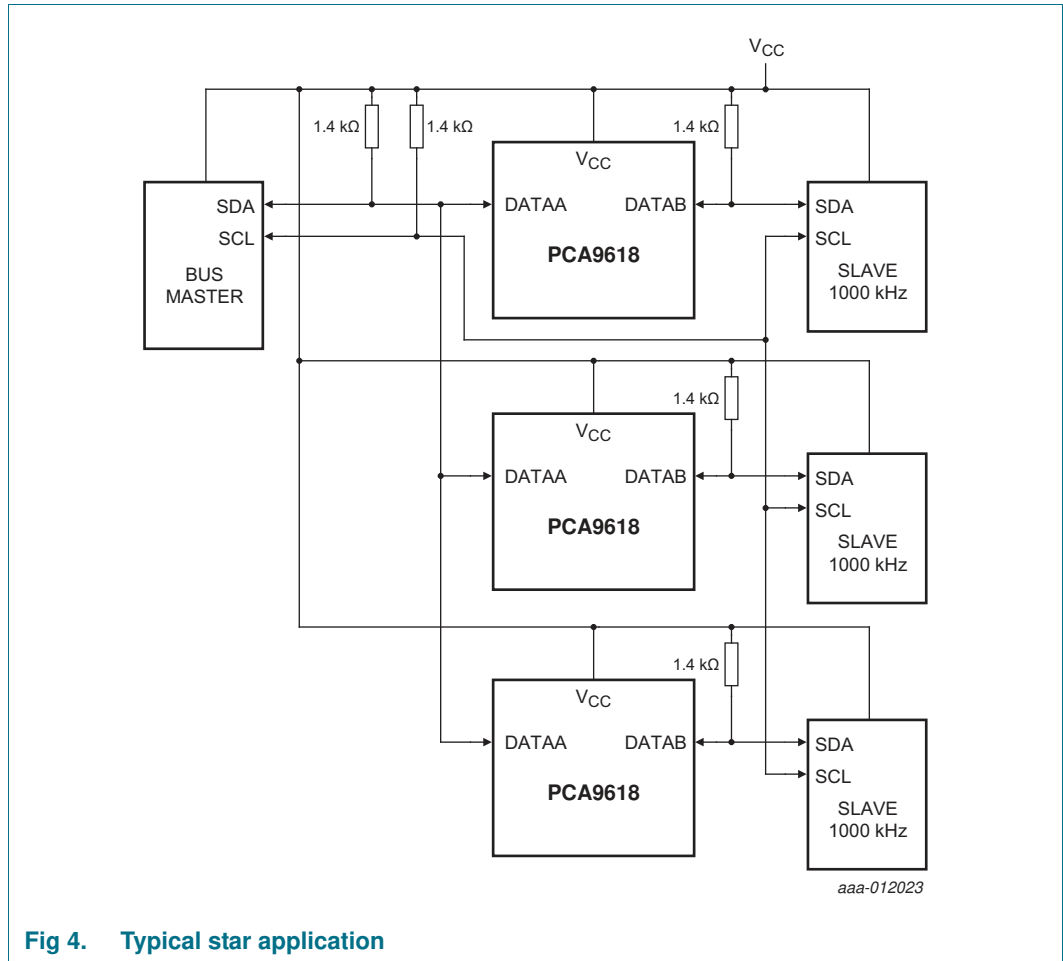
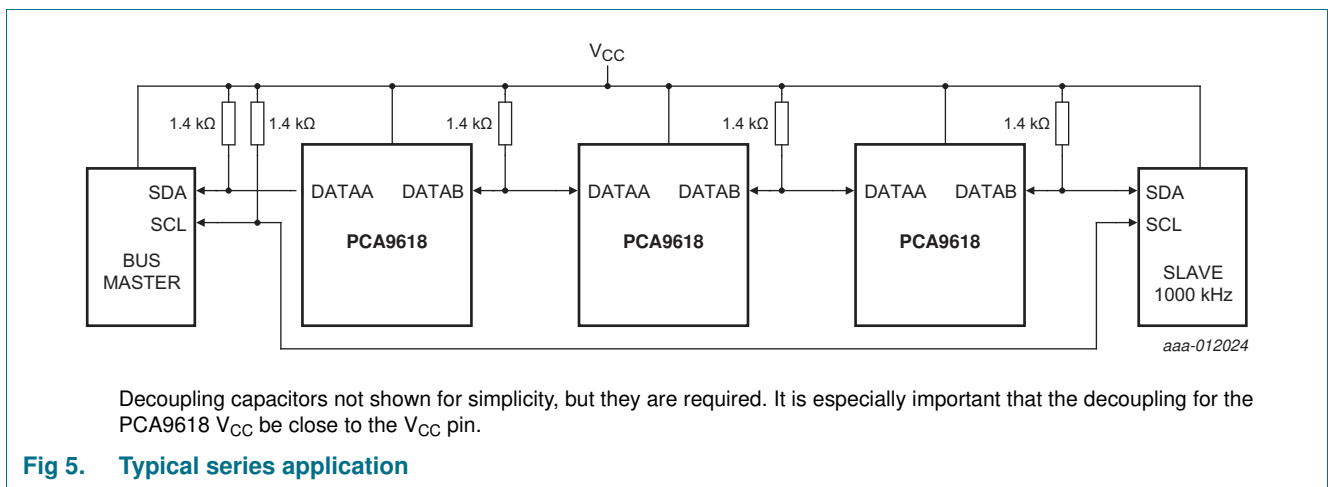

Fig 4. Typical star application

The PCA9618 provides two basic functions. It provides buffering and it provides a delay that can be used to delay the SDA in order to create an artificial hold time bridge the gap between the 0 ns I<sup>2</sup>C-bus hold time on SCL falling edge and the SMBus 300 ns hold time specification for SMBus slaves that are clocked on the SCL falling edge and not sampled.



Decoupling capacitors not shown for simplicity, but they are required. It is especially important that the decoupling for the PCA9618 V<sub>CC</sub> be close to the V<sub>CC</sub> pin.

Fig 5. Typical series application

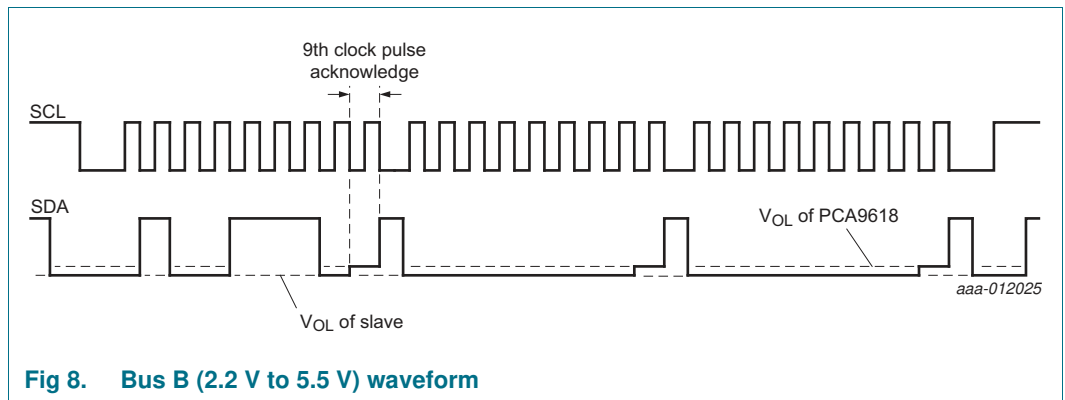
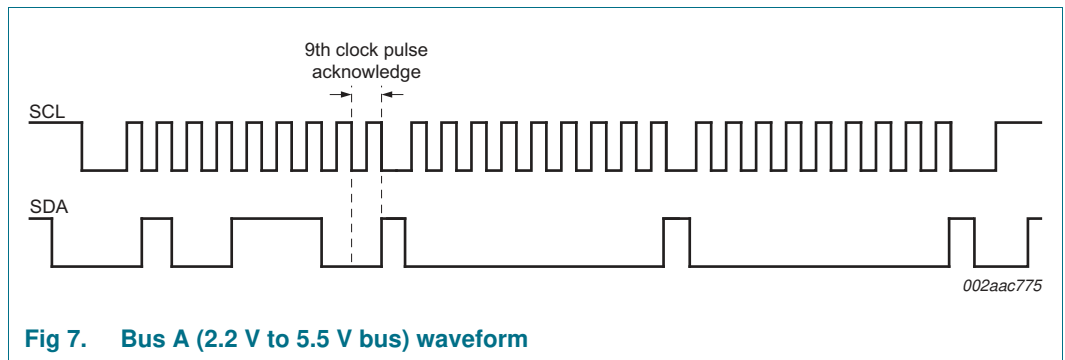
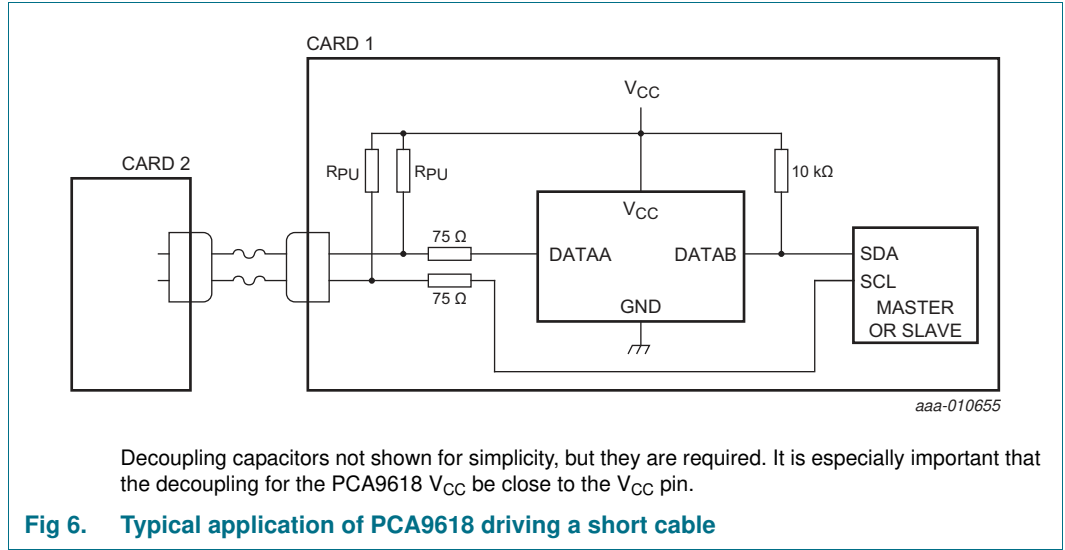

## 8. Limiting values

**Table 4. Limiting values**

*In accordance with the Absolute Maximum Rating System (IEC 60134).*

| Symbol           | Parameter                      | Conditions            | Min  | Max  | Unit |
|------------------|--------------------------------|-----------------------|------|------|------|
| V <sub>CC</sub>  | supply voltage                 |                       | -0.5 | +7   | V    |
| V <sub>I/O</sub> | voltage on an input/output pin | port A and port B     | -0.5 | +7   | V    |
| I <sub>I/O</sub> | input/output current           | port A; port B        | -    | 50   | mA   |
| I <sub>I</sub>   | input current                  | V <sub>CC</sub> , GND | -    | 50   | mA   |
| P <sub>tot</sub> | total power dissipation        |                       | -    | 100  | mW   |
| T <sub>stg</sub> | storage temperature            |                       | -55  | +125 | °C   |
| T <sub>amb</sub> | ambient temperature            | operating in free air | -40  | +85  | °C   |
| T <sub>j</sub>   | junction temperature           |                       | -    | +125 | °C   |



## 9. Static characteristics

**Table 5. Static characteristics**

$V_{CC} = 2.2\text{ V to }5.5\text{ V}$ ;  $GND = 0\text{ V}$ ;  $T_{amb} = -40\text{ }^{\circ}\text{C to }+85\text{ }^{\circ}\text{C}$ ; unless otherwise specified.

Typical values measured with  $V_{CC} = 2.5\text{ V}$  at  $25\text{ }^{\circ}\text{C}$ , unless otherwise noted.

| Symbol                        | Parameter   | Conditions  | Min         | Typ  | Max           | Unit          |
|-------------------------------|---|---|-------------|------|---------------|---------------|
| <b>Supplies</b>               |   |   |             |      |               |               |
| $V_{CC}$                      | supply voltage  |   | 2.2         | -    | 5.5           | V             |
| $I_{CCH}$                     | HIGH-level supply current   | $V_{CC} = 5.5\text{ V}$ ; $DATA_n = V_{CC}$   | -           | 1.5  | 2.5           | mA            |
| $I_{CCL}$                     | LOW-level supply current  | $V_{CC} = 5.5\text{ V}$ ; one $DATA_n = GND$ ;<br>other $DATA_n$ with pull-up resistors | -           | 1.7  | 2.9           | mA            |
| <b>Input and output DATAB</b> |   |   |             |      |               |               |
| $V_{IH}$                      | HIGH-level input voltage  |   | $0.7V_{CC}$ | -    | 5.5           | V             |
| $V_{IL}$                      | LOW-level input voltage   |   | -0.5        | -    | +0.4          | V             |
| $V_{IK}$                      | input clamping voltage  | $I_I = -18\text{ mA}$   | -1.2        | -    | -0.3          | V             |
| $I_{LI}$                      | input leakage current   | $V_I = 5.5\text{ V}$  | -           | -    | $\pm 1$       | $\mu\text{A}$ |
| $I_{OL}$                      | LOW-level output current  | $V_O = 0.2\text{ V}$  | -10         | -    | +120          | $\mu\text{A}$ |
| $V_{OL}$                      | LOW-level output voltage  | $I_{OL} = 150\text{ }\mu\text{A}$ at $V_{CC} = 2.2\text{ V}$                            | [1] 0.47    | -    | -             | V             |
|                               |   | $I_{OL} = 13\text{ mA}$ at $V_{CC} = 2.2\text{ V}$                                      | [2] -       | 0.54 | 0.61          | V             |
| $V_{OL}-V_{IL}$               | difference between<br>LOW-level output and<br>LOW-level input voltage | $V_{OL}$ at $I_{OL} = 1\text{ mA}$ ;<br>guaranteed by design                            | 60          | 90   | 160           | mV            |
| $C_{io}$                      | input/output capacitance  | $V_I = 3\text{ V}$ or $0\text{ V}$ ; $V_{CC} = 3.3\text{ V}$                            | -           | 7    | 10            | pF            |
|                               |   | $V_I = 3\text{ V}$ or $0\text{ V}$ ; $V_{CC} = 0\text{ V}$                              | -           | 7    | 10            | pF            |
| <b>Input and output DATAA</b> |   |   |             |      |               |               |
| $V_{IH}$                      | HIGH-level input voltage  |   | $0.7V_{CC}$ | -    | 5.5           | V             |
| $V_{IL}$                      | LOW-level input voltage   |   | [3] -0.5    | -    | $+0.25V_{CC}$ | V             |
| $V_{IK}$                      | input clamping voltage  | $I_I = -18\text{ mA}$   | -1.2        | -    | -0.3          | V             |
| $I_{LI}$                      | input leakage current   | $V_I = 5.5\text{ V}$  | -           | -    | $\pm 1$       | $\mu\text{A}$ |
| $I_{IL}$                      | LOW-level input current   | $V_I = 0.2\text{ V}$  | -           | -    | 10            | $\mu\text{A}$ |
| $V_{OL}$                      | LOW-level output voltage  | $I_{OL} = 13\text{ mA}$ ; $V_{CC} = 2.2\text{ V}$                                       | -           | 0.1  | 0.2           | V             |
| $C_{io}$                      | input/output capacitance  | $V_I = 3\text{ V}$ or $0\text{ V}$ ; $V_{CC} = 3.3\text{ V}$                            | -           | 7    | 10            | pF            |
|                               |   | $V_I = 3\text{ V}$ or $0\text{ V}$ ; $V_{CC} = 0\text{ V}$                              | -           | 7    | 10            | pF            |

[1] Pull-up should result in  $I_{OL} \geq 150\text{ }\mu\text{A}$ .

[2] Guaranteed by design and characterization.

[3]  $V_{IL}$  for port A with envelope noise must be below  $0.3V_{CC}$  for stable performance.

[4] Power supply decoupling capacitors need to be present for  $V_{CC}$  and the  $0.1\text{ }\mu\text{F}$  decoupling for  $V_{CC}$  needs to be located near the  $V_{CC}$  pin.

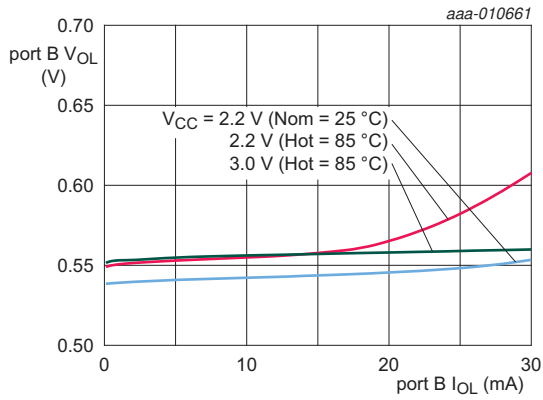

Fig 9. Port B  $V_{OL}$  versus  $I_{OL}$

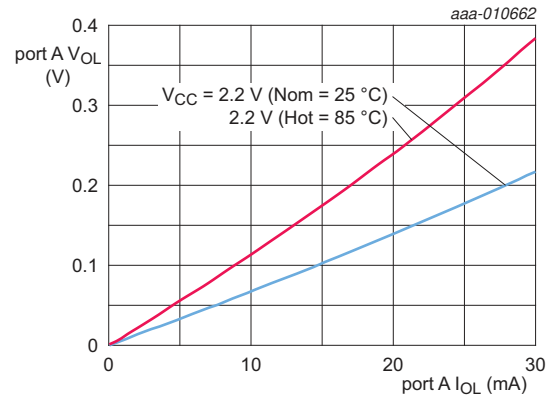
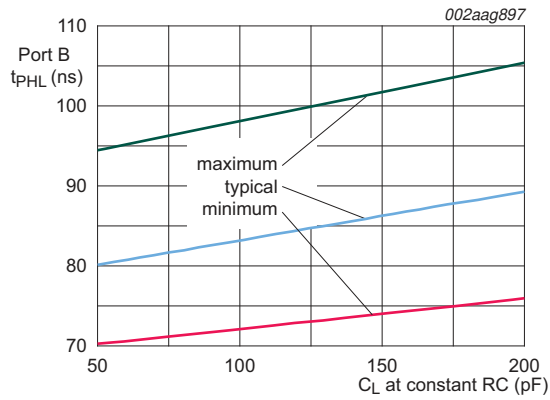

Fig 10. Port A  $V_{OL}$  versus  $I_{OL}$



RC = 67.5 ns,  $V_{CC}$  = 2.5 V, and  $T_{amb}$  = 25 °C.

Fig 11. Nominal port B  $t_{PHL}$  with load capacitance at constant RC

## 10. Dynamic characteristics

**Table 6. Dynamic characteristics**

$V_{CC} = 2.2\text{ V to }5.5\text{ V}$ ;  $GND = 0\text{ V}$ ;  $T_{amb} = -40\text{ }^{\circ}\text{C to }+85\text{ }^{\circ}\text{C}$ ; unless otherwise specified.<sup>[1][2]</sup>

| Symbol     | Parameter                          | Conditions                                  | Min               | Typ <sup>[3]</sup> | Max  | Unit |
|------------|------------------------------------|---|-------------------|--------------------|------|------|
| $t_{PLH}$  | LOW to HIGH propagation delay      | port B to port A; <a href="#">Figure 14</a> | -42               | -65                | -103 | ns   |
| $t_{PLH2}$ | LOW to HIGH propagation delay 2    | port B to port A; <a href="#">Figure 14</a> | <sup>[4]</sup> 67 | 94                 | 130  | ns   |
| $t_{PHL}$  | HIGH to LOW propagation delay      | port B to port A; <a href="#">Figure 12</a> | 46                | 76                 | 152  | ns   |
| $t_{TLH}$  | LOW to HIGH output transition time | port A; <a href="#">Figure 12</a>           | <sup>[5]</sup> -  | 60                 | -    | ns   |
| $SR_f$     | falling slew rate                  | port A; $0.7V_{CC}$ to $0.3V_{CC}$          | 0.022             | 0.037              | 0.11 | V/ns |
| $t_{PLH}$  | LOW to HIGH propagation delay      | port A to port B; <a href="#">Figure 13</a> | <sup>[6]</sup> 40 | 60                 | 102  | ns   |
| $t_{PHL}$  | HIGH to LOW propagation delay      | port A to port B; <a href="#">Figure 13</a> | <sup>[6]</sup> 63 | 80                 | 173  | ns   |
| $t_{TLH}$  | LOW to HIGH output transition time | port B; <a href="#">Figure 13</a>           | <sup>[5]</sup> -  | 60                 | -    | ns   |
| $SR_f$     | falling slew rate                  | port B; $0.7V_{CC}$ to $0.3V_{CC}$          | 0.029             | 0.056              | 0.09 | V/ns |

- [1] Times are specified with loads of 1.35 kΩ pull-up resistance and 50 pF load capacitance on port A and port B, and a falling edge slew rate of 0.05 V/ns input signals.
- [2] Pull-up voltages are  $V_{CC}$  on port A and  $V_{CC}$  on port B.
- [3] Typical values were measured with  $V_{CC} = 2.5\text{ V}$  at  $T_{amb} = 25\text{ }^{\circ}\text{C}$ , unless otherwise noted.
- [4] The  $t_{PLH2}$  delay data from port B to port A is measured at 0.45 V on port B to  $0.5V_{CC}$  on port A.
- [5] The  $t_{TLH}$  of the bus is determined by the pull-up resistance (1.35 kΩ) and the total capacitance (50 pF).
- [6] The proportional delay data from port A to port B is measured at  $0.5V_{CC}$  on port A to  $0.5V_{CC}$  on port B.

### 10.1 AC waveforms

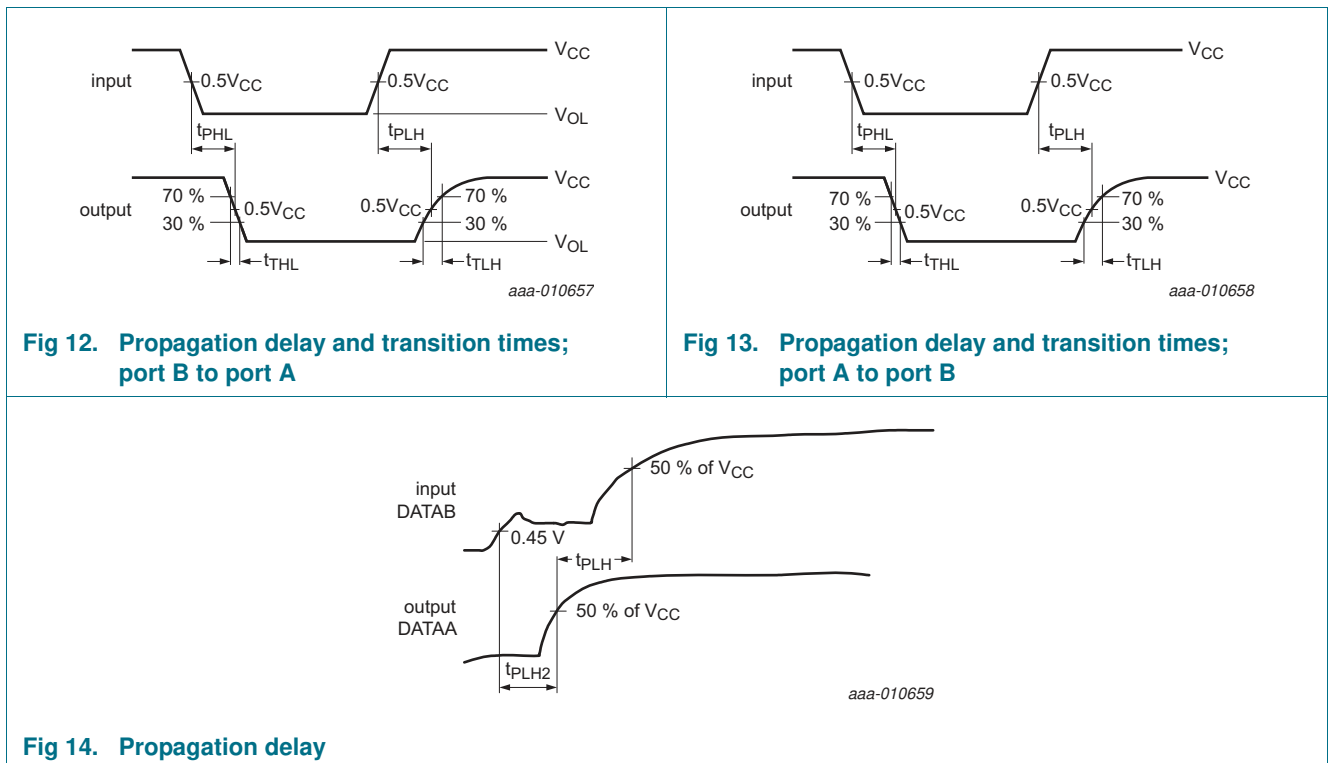

## 11. Test information

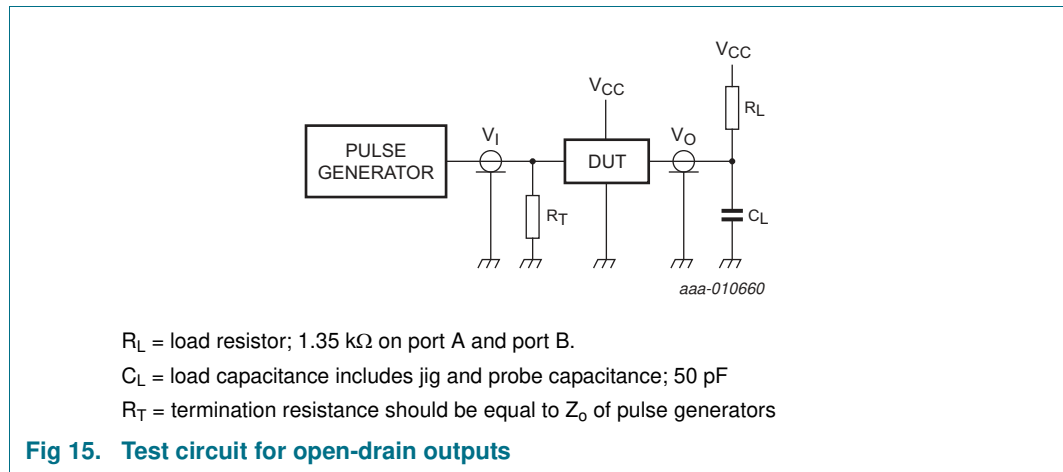

## 12. Package outline

WLCSP4: wafer level chip-scale package; 4 bumps; 0.83 x 0.78 x 0.53 mm (backside coating included)

SOT1375-3

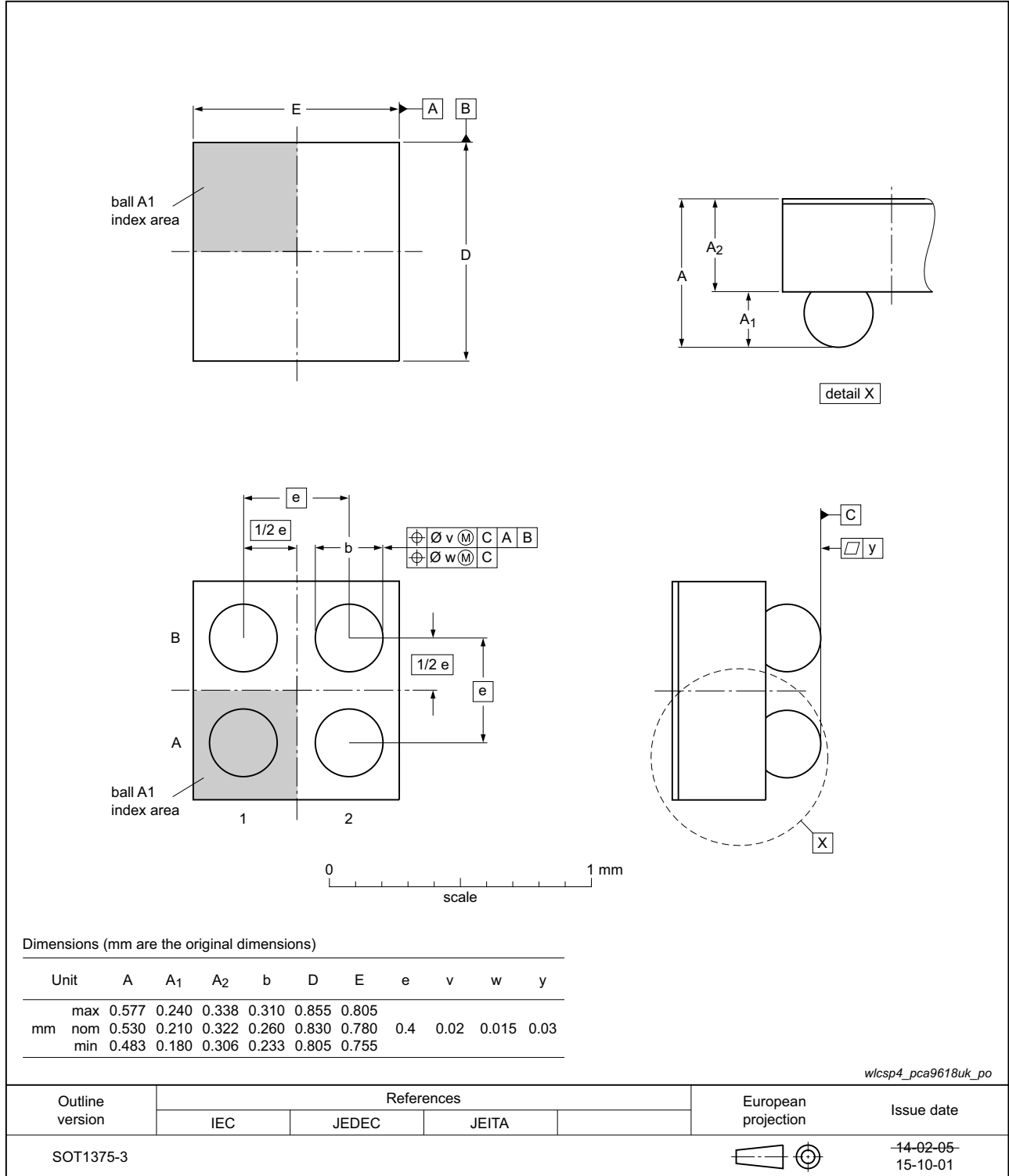
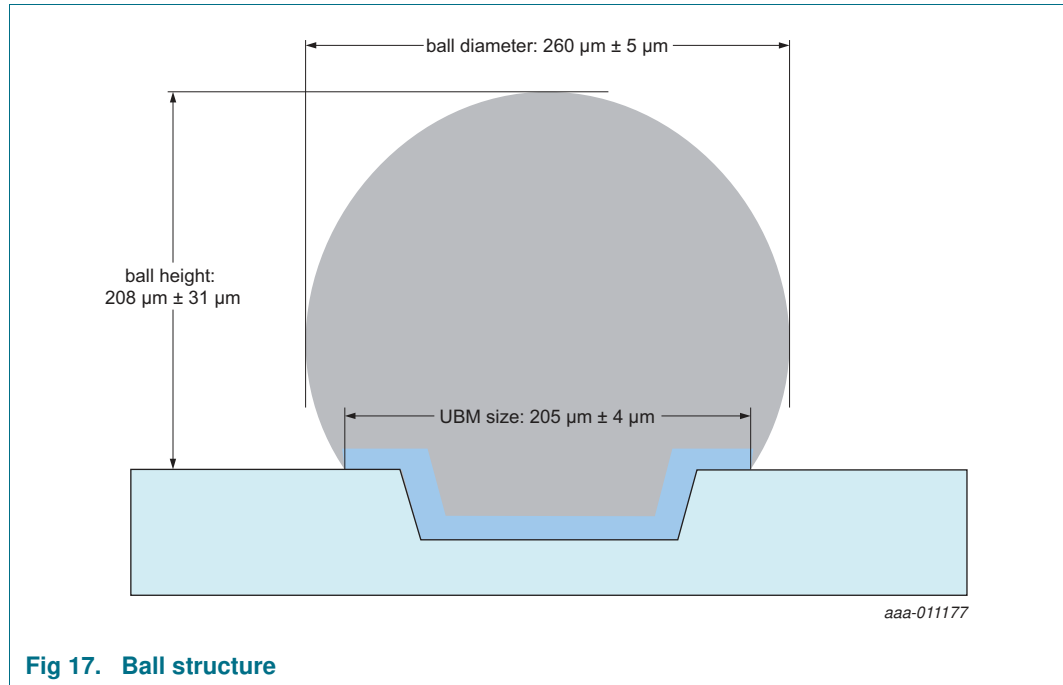

Fig 16. Package outline PCA9618UK (WLCSP4)



## 13. Soldering of WLCSP packages

### 13.1 Introduction to soldering WLCSP packages

This text provides a very brief insight into a complex technology. A more in-depth account of soldering WLCSP (Wafer Level Chip-Size Packages) can be found in application note AN10439 "Wafer Level Chip Scale Package" and in application note AN10365 "Surface mount reflow soldering description".

Wave soldering is not suitable for this package.

All NXP WLCSP packages are lead-free.

### 13.2 Board mounting

Board mounting of a WLCSP requires several steps:

1. Solder paste printing on the PCB
2. Component placement with a pick and place machine
3. The reflow soldering itself

### 13.3 Reflow soldering

Key characteristics in reflow soldering are:

- Lead-free versus SnPb soldering; note that a lead-free reflow process usually leads to higher minimum peak temperatures (see [Figure 18](#)) than a SnPb process, thus reducing the process window
- Solder paste printing issues, such as smearing, release, and adjusting the process window for a mix of large and small components on one board

- Reflow temperature profile; this profile includes preheat, reflow (in which the board is heated to the peak temperature), and cooling down. It is imperative that the peak temperature is high enough for the solder to make reliable solder joints (a solder paste characteristic) while being low enough that the packages and/or boards are not damaged. The peak temperature of the package depends on package thickness and volume and is classified in accordance with [Table 7](#).

**Table 7. Lead-free process (from J-STD-020D)**

| Package thickness (mm) | Package reflow temperature (°C) |             |        |
|------------------------|---------------------------------|-------------|--------|
|                        | Volume (mm <sup>3</sup> )       |             |        |
|                        | < 350                           | 350 to 2000 | > 2000 |
| < 1.6                  | 260                             | 260         | 260    |
| 1.6 to 2.5             | 260                             | 250         | 245    |
| > 2.5                  | 250                             | 245         | 245    |

Moisture sensitivity precautions, as indicated on the packing, must be respected at all times.

Studies have shown that small packages reach higher temperatures during reflow soldering, see [Figure 18](#).

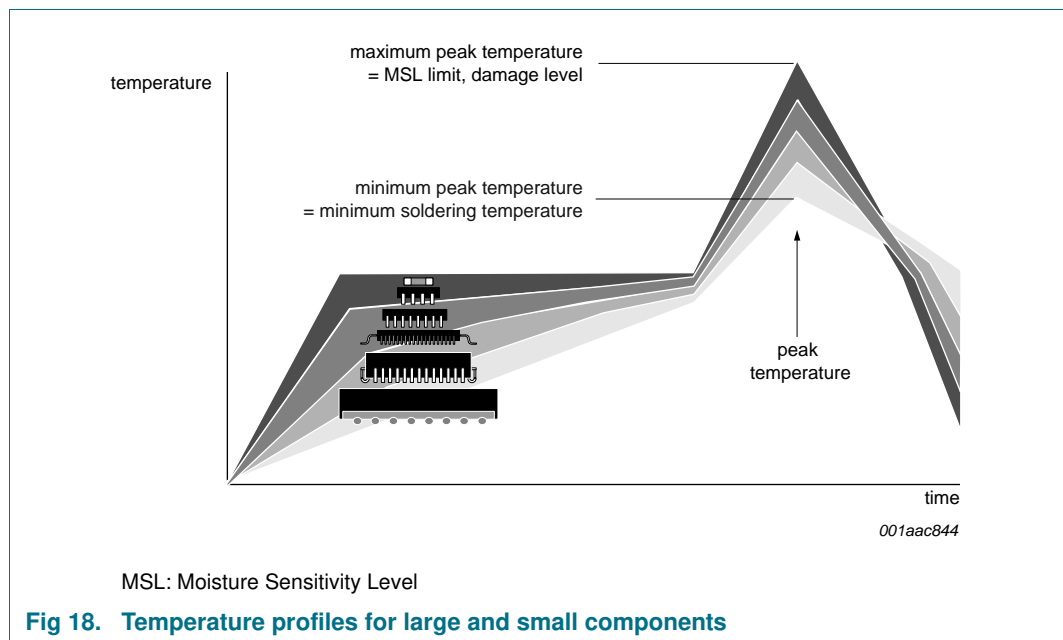

For further information on temperature profiles, refer to application note *AN10365 "Surface mount reflow soldering description"*.

### 13.3.1 Stand off

The stand off between the substrate and the chip is determined by:

- The amount of printed solder on the substrate
- The size of the solder land on the substrate
- The bump height on the chip

The higher the stand off, the better the stresses are released due to TEC (Thermal Expansion Coefficient) differences between substrate and chip.

### 13.3.2 Quality of solder joint

A flip-chip joint is considered to be a good joint when the entire solder land has been wetted by the solder from the bump. The surface of the joint should be smooth and the shape symmetrical. The soldered joints on a chip should be uniform. Voids in the bumps after reflow can occur during the reflow process in bumps with high ratio of bump diameter to bump height, i.e. low bumps with large diameter. No failures have been found to be related to these voids. Solder joint inspection after reflow can be done with X-ray to monitor defects such as bridging, open circuits and voids.

### 13.3.3 Rework

In general, rework is not recommended. By rework we mean the process of removing the chip from the substrate and replacing it with a new chip. If a chip is removed from the substrate, most solder balls of the chip will be damaged. In that case it is recommended not to re-use the chip again.

Device removal can be done when the substrate is heated until it is certain that all solder joints are molten. The chip can then be carefully removed from the substrate without damaging the tracks and solder lands on the substrate. Removing the device must be done using plastic tweezers, because metal tweezers can damage the silicon. The surface of the substrate should be carefully cleaned and all solder and flux residues and/or underfill removed. When a new chip is placed on the substrate, use the flux process instead of solder on the solder lands. Apply flux on the bumps at the chip side as well as on the solder pads on the substrate. Place and align the new chip while viewing with a microscope. To reflow the solder, use the solder profile shown in application note AN10365 "Surface mount reflow soldering description".

### 13.3.4 Cleaning

Cleaning can be done after reflow soldering.



### 14. Soldering: PCB footprints

Footprint information for reflow soldering of WLCSP4 package

PCA9618\_SMD

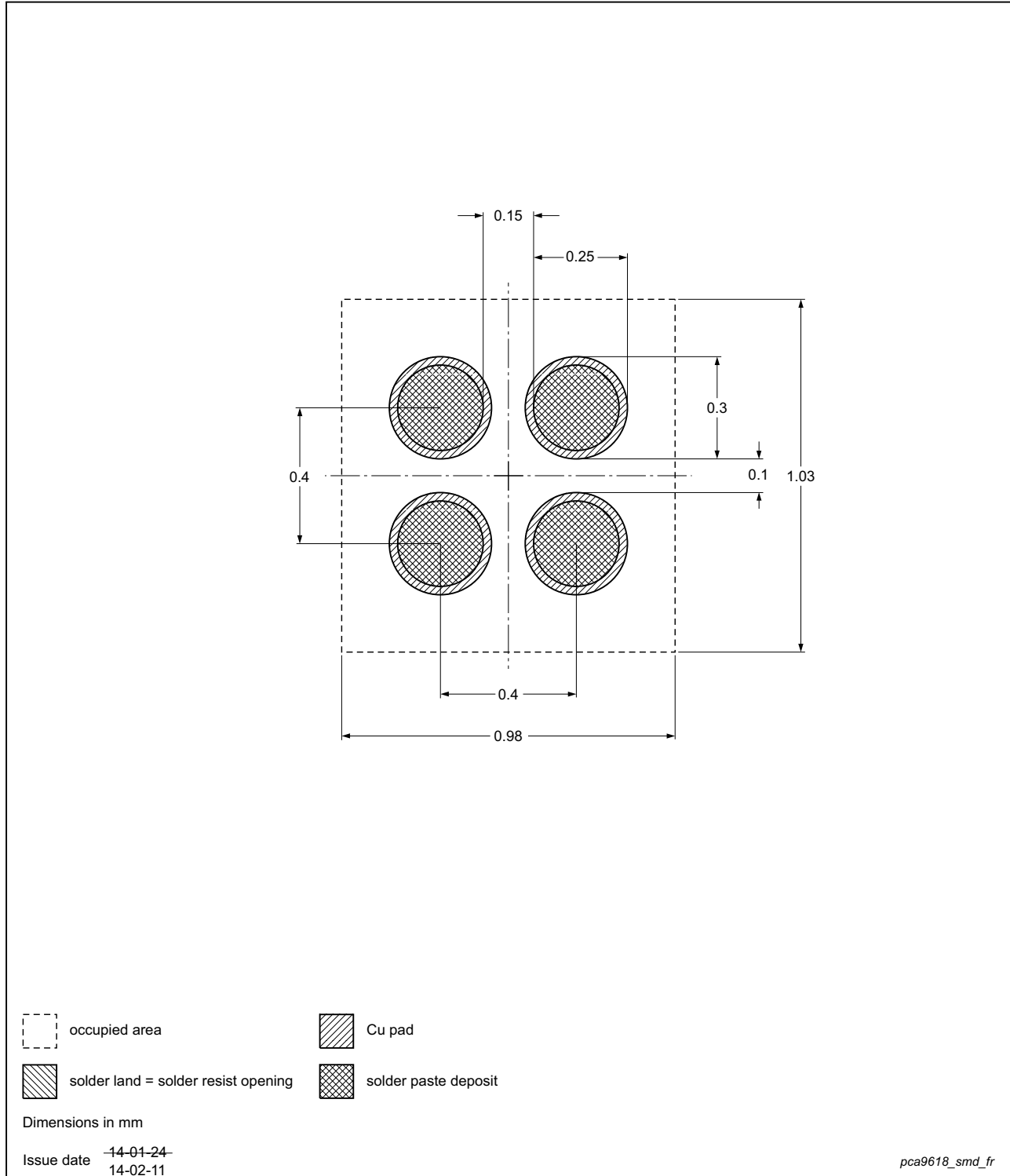
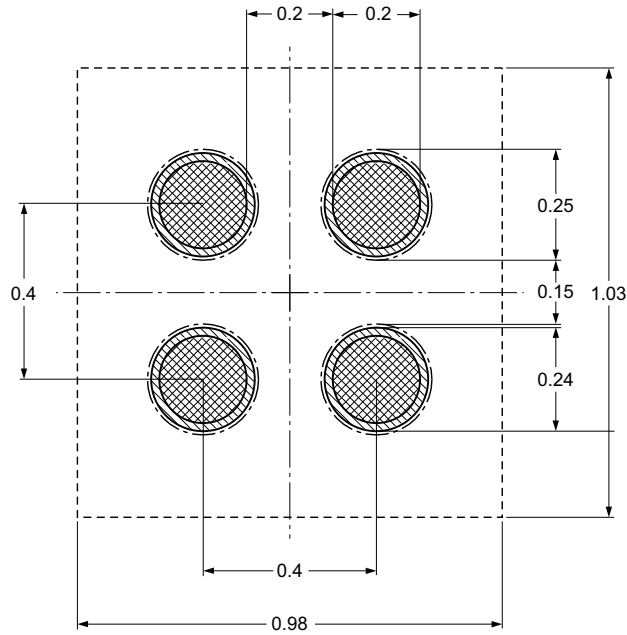





Fig 19. PCB footprint for PCA9618UK (WLCSP4); reflow soldering; Solder Mask Defined (SMD)

Footprint information for reflow soldering of WLCSP4 package

PCA9618\_NSMD



-  occupied area
-  solder resist
-  solder land = Cu pad
-  solder paste deposit

Dimensions in mm

Issue date ~~14-01-24~~  
14-02-11

pca9618\_nsmd\_fr

Fig 20. PCB footprint for PCA9618UK (WLCSP4); reflow soldering; Non-Solder Mask Defined (NSMD)

## 15. Abbreviations

**Table 8. Abbreviations**

| Acronym              | Description                             |
|----------------------|---|
| CDM                  | Charged-Device Model                    |
| CMOS                 | Complementary Metal-Oxide Semiconductor |
| ESD                  | ElectroStatic Discharge                 |
| HBM                  | Human Body Model                        |
| I <sup>2</sup> C-bus | Inter-Integrated Circuit bus            |
| I/O                  | Input/Output                            |
| PMBus                | Power Management Bus                    |
| RC                   | Resistor-Capacitor network              |
| SMBus                | System Management Bus                   |

## 16. Revision history

**Table 9. Revision history**

| Document ID | Release date | Data sheet status  | Change notice | Supersedes |
|-------------|--------------|--------------------|---------------|------------|
| PCA9618 v.1 | 20160113     | Product data sheet | -             | -          |

## 17. Legal information

### 17.1 Data sheet status

| Document status <sup>[1][2]</sup> | Product status <sup>[3]</sup> | Definition  |
|-----------------------------------|-------------------------------|---|
| Objective [short] data sheet      | Development                   | This document contains data from the objective specification for product development. |
| Preliminary [short] data sheet    | Qualification                 | This document contains data from the preliminary specification.                       |
| Product [short] data sheet        | Production                    | This document contains the product specification.                                     |

[1] Please consult the most recently issued document before initiating or completing a design.

[2] The term 'short data sheet' is explained in section "Definitions".

[3] The product status of device(s) described in this document may have changed since this document was published and may differ in case of multiple devices. The latest product status information is available on the Internet at URL <http://www.nxp.com>.

### 17.2 Definitions

**Draft** — The document is a draft version only. The content is still under internal review and subject to formal approval, which may result in modifications or additions. NXP Semiconductors does not give any representations or warranties as to the accuracy or completeness of information included herein and shall have no liability for the consequences of use of such information.

**Short data sheet** — A short data sheet is an extract from a full data sheet with the same product type number(s) and title. A short data sheet is intended for quick reference only and should not be relied upon to contain detailed and full information. For detailed and full information see the relevant full data sheet, which is available on request via the local NXP Semiconductors sales office. In case of any inconsistency or conflict with the short data sheet, the full data sheet shall prevail.

**Product specification** — The information and data provided in a Product data sheet shall define the specification of the product as agreed between NXP Semiconductors and its customer, unless NXP Semiconductors and customer have explicitly agreed otherwise in writing. In no event however, shall an agreement be valid in which the NXP Semiconductors product is deemed to offer functions and qualities beyond those described in the Product data sheet.

### 17.3 Disclaimers

**Limited warranty and liability** — Information in this document is believed to be accurate and reliable. However, NXP Semiconductors does not give any representations or warranties, expressed or implied, as to the accuracy or completeness of such information and shall have no liability for the consequences of use of such information. NXP Semiconductors takes no responsibility for the content in this document if provided by an information source outside of NXP Semiconductors.

In no event shall NXP Semiconductors be liable for any indirect, incidental, punitive, special or consequential damages (including - without limitation - lost profits, lost savings, business interruption, costs related to the removal or replacement of any products or rework charges) whether or not such damages are based on tort (including negligence), warranty, breach of contract or any other legal theory.

Notwithstanding any damages that customer might incur for any reason whatsoever, NXP Semiconductors' aggregate and cumulative liability towards customer for the products described herein shall be limited in accordance with the *Terms and conditions of commercial sale* of NXP Semiconductors.

**Right to make changes** — NXP Semiconductors reserves the right to make changes to information published in this document, including without limitation specifications and product descriptions, at any time and without notice. This document supersedes and replaces all information supplied prior to the publication hereof.

**Suitability for use** — NXP Semiconductors products are not designed, authorized or warranted to be suitable for use in life support, life-critical or safety-critical systems or equipment, nor in applications where failure or malfunction of an NXP Semiconductors product can reasonably be expected to result in personal injury, death or severe property or environmental damage. NXP Semiconductors and its suppliers accept no liability for inclusion and/or use of NXP Semiconductors products in such equipment or applications and therefore such inclusion and/or use is at the customer's own risk.

**Applications** — Applications that are described herein for any of these products are for illustrative purposes only. NXP Semiconductors makes no representation or warranty that such applications will be suitable for the specified use without further testing or modification.

Customers are responsible for the design and operation of their applications and products using NXP Semiconductors products, and NXP Semiconductors accepts no liability for any assistance with applications or customer product design. It is customer's sole responsibility to determine whether the NXP Semiconductors product is suitable and fit for the customer's applications and products planned, as well as for the planned application and use of customer's third party customer(s). Customers should provide appropriate design and operating safeguards to minimize the risks associated with their applications and products.

NXP Semiconductors does not accept any liability related to any default, damage, costs or problem which is based on any weakness or default in the customer's applications or products, or the application or use by customer's third party customer(s). Customer is responsible for doing all necessary testing for the customer's applications and products using NXP Semiconductors products in order to avoid a default of the applications and the products or of the application or use by customer's third party customer(s). NXP does not accept any liability in this respect.

**Limiting values** — Stress above one or more limiting values (as defined in the Absolute Maximum Ratings System of IEC 60134) will cause permanent damage to the device. Limiting values are stress ratings only and (proper) operation of the device at these or any other conditions above those given in the Recommended operating conditions section (if present) or the Characteristics sections of this document is not warranted. Constant or repeated exposure to limiting values will permanently and irreversibly affect the quality and reliability of the device.

**Terms and conditions of commercial sale** — NXP Semiconductors products are sold subject to the general terms and conditions of commercial sale, as published at <http://www.nxp.com/profile/terms>, unless otherwise agreed in a valid written individual agreement. In case an individual agreement is concluded only the terms and conditions of the respective agreement shall apply. NXP Semiconductors hereby expressly objects to applying the customer's general terms and conditions with regard to the purchase of NXP Semiconductors products by customer.

**No offer to sell or license** — Nothing in this document may be interpreted or construed as an offer to sell products that is open for acceptance or the grant, conveyance or implication of any license under any copyrights, patents or other industrial or intellectual property rights.

**Export control** — This document as well as the item(s) described herein may be subject to export control regulations. Export might require a prior authorization from competent authorities.

**Non-automotive qualified products** — Unless this data sheet expressly states that this specific NXP Semiconductors product is automotive qualified, the product is not suitable for automotive use. It is neither qualified nor tested in accordance with automotive testing or application requirements. NXP Semiconductors accepts no liability for inclusion and/or use of non-automotive qualified products in automotive equipment or applications.

In the event that customer uses the product for design-in and use in automotive applications to automotive specifications and standards, customer (a) shall use the product without NXP Semiconductors' warranty of the product for such automotive applications, use and specifications, and (b) whenever customer uses the product for automotive applications beyond NXP Semiconductors' specifications such use shall be solely at customer's

own risk, and (c) customer fully indemnifies NXP Semiconductors for any liability, damages or failed product claims resulting from customer design and use of the product for automotive applications beyond NXP Semiconductors' standard warranty and NXP Semiconductors' product specifications.

**Translations** — A non-English (translated) version of a document is for reference only. The English version shall prevail in case of any discrepancy between the translated and English versions.

## 17.4 Trademarks

Notice: All referenced brands, product names, service names and trademarks are the property of their respective owners.

**I<sup>2</sup>C-bus** — logo is a trademark of NXP B.V.

## 18. Contact information

For more information, please visit: <http://www.nxp.com>

For sales office addresses, please send an email to: [salesaddresses@nxp.com](mailto:salesaddresses@nxp.com)

## 19. Contents

|           |  |           |
|-----------|--|-----------|
| <b>1</b>  | <b>General description</b> .....               | <b>1</b>  |
| <b>2</b>  | <b>Features and benefits</b> .....             | <b>2</b>  |
| <b>3</b>  | <b>Ordering information</b> .....              | <b>2</b>  |
| 3.1       | Ordering options .....                         | 2         |
| <b>4</b>  | <b>Functional diagram</b> .....                | <b>3</b>  |
| <b>5</b>  | <b>Pinning information</b> .....               | <b>3</b>  |
| 5.1       | Pinning .....                                  | 3         |
| 5.2       | Pin description .....                          | 3         |
| <b>6</b>  | <b>Functional description</b> .....            | <b>4</b>  |
| 6.1       | I <sup>2</sup> C-bus systems .....             | 4         |
| <b>7</b>  | <b>Application design-in information</b> ..... | <b>5</b>  |
| <b>8</b>  | <b>Limiting values</b> .....                   | <b>8</b>  |
| <b>9</b>  | <b>Static characteristics</b> .....            | <b>9</b>  |
| <b>10</b> | <b>Dynamic characteristics</b> .....           | <b>11</b> |
| 10.1      | AC waveforms .....                             | 11        |
| <b>11</b> | <b>Test information</b> .....                  | <b>12</b> |
| <b>12</b> | <b>Package outline</b> .....                   | <b>13</b> |
| <b>13</b> | <b>Soldering of WLCSP packages</b> .....       | <b>15</b> |
| 13.1      | Introduction to soldering WLCSP packages ..    | 15        |
| 13.2      | Board mounting .....                           | 15        |
| 13.3      | Reflow soldering .....                         | 15        |
| 13.3.1    | Stand off .....                                | 16        |
| 13.3.2    | Quality of solder joint .....                  | 16        |
| 13.3.3    | Rework .....                                   | 16        |
| 13.3.4    | Cleaning .....                                 | 17        |
| <b>14</b> | <b>Soldering: PCB footprints</b> .....         | <b>18</b> |
| <b>15</b> | <b>Abbreviations</b> .....                     | <b>20</b> |
| <b>16</b> | <b>Revision history</b> .....                  | <b>20</b> |
| <b>17</b> | <b>Legal information</b> .....                 | <b>21</b> |
| 17.1      | Data sheet status .....                        | 21        |
| 17.2      | Definitions .....                              | 21        |
| 17.3      | Disclaimers .....                              | 21        |
| 17.4      | Trademarks .....                               | 22        |
| <b>18</b> | <b>Contact information</b> .....               | <b>22</b> |
| <b>19</b> | <b>Contents</b> .....                          | <b>23</b> |

Please be aware that important notices concerning this document and the product(s) described herein, have been included in section 'Legal information'.

© NXP B.V. 2016.

All rights reserved.

For more information, please visit: <http://www.nxp.com>

For sales office addresses, please send an email to: [salesaddresses@nxp.com](mailto:salesaddresses@nxp.com)

Date of release: 13 January 2016

Document identifier: PCA9618