

# 800 W PFC evaluation board

EVAL\_800W\_PFC\_C7\_V2 / SP001647120 / SA001647124

High power density 800 W 130 kHz platinum server design  
with analog & digital control

Garcia Rafael (IFAT PMM ACDC AE)

Zechner Florian (IFAT PMM ACDC AE)



# Table of contents

1 General description

2 Test results

3 Design concept

# Table of contents

1

General description

2

Test results

3

Design concept

# General

## Description:

- › The “**EVAL\_800W\_PFC\_C7\_V2**” evaluation board shows how to design an high power density 800 W 130 kHz platinum server supply with power factor correction (PFC) boost converter working in continuous conduction mode (CCM). On this purpose the latest CoolMOS™ technology [IPP60R180C7](#) 600 V power MOSFET, [IDH06G65C5](#) 650 V CoolSiC™ Schottky diode generation 5, [ICE3PCS01G](#) PFC controller, low-side non-isolated gate driver [2EDN7524F](#) EiceDRIVER™, [XMC1400](#) microcontroller and quasi resonant CoolSET™ [ICE2QR2280Z](#) have been applied.

## Summary of features:

- › Output voltage: 380 V<sub>DC</sub>
- › Output current: 2.1 A
- › Efficiency: >96% @ 20% load, V<sub>in</sub> = 230 V<sub>DC</sub>
- › Switching frequency: 130 kHz

## The following variant is available:

- › 800 W 130 kHz PFC version with CoolMOS™ C7, [IPP60R180C7](#), **EVAL\_800W\_PFC\_C7\_V2**

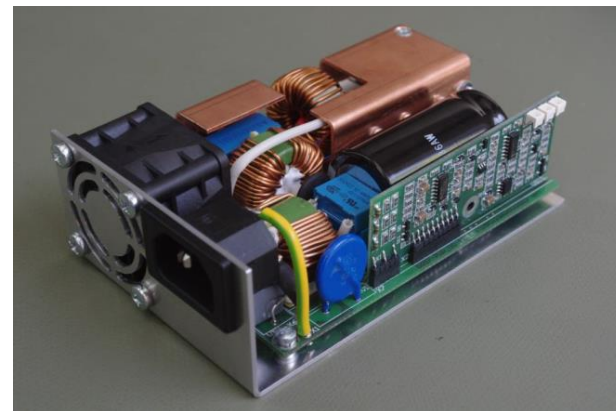

# Infineon high power density 800 W 130 kHz platinum server design



**PWM controller**  
**CoolSET™ ICE2QR2280Z**

**Silicon carbide diode**  
**5th Gen CoolSiC™ IDH06G65C5**

**Power MOSFETs**  
**CoolMOS™ IPP60R180C7**



**Microcontroller XMC1400**  
**DIGITAL**  
**XMC1402-Q040X0128 AA**

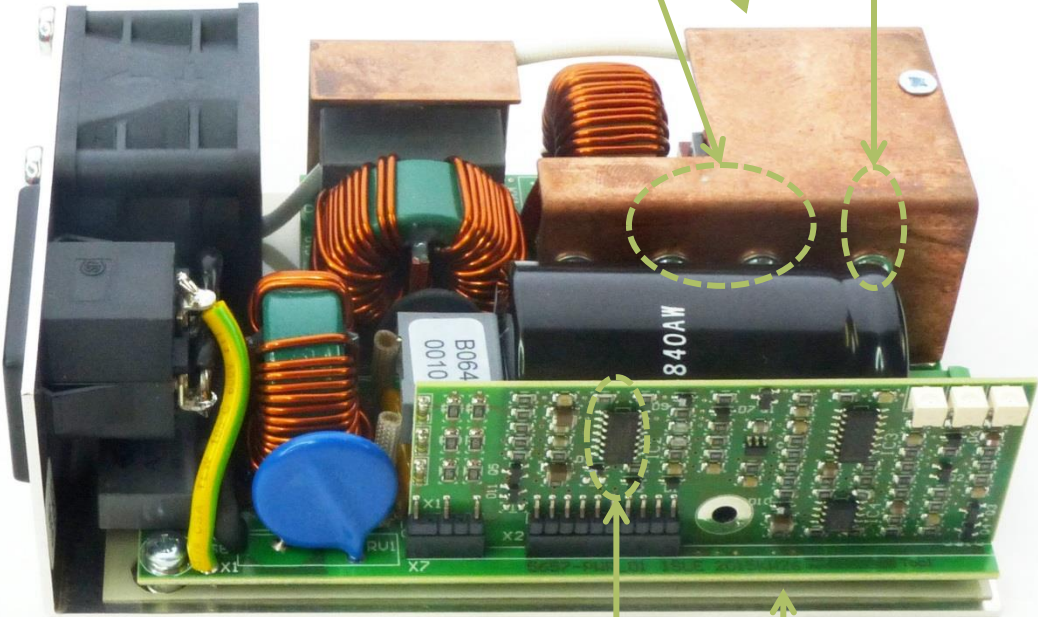

**PFC CCM controller**  
**ANALOG**  
**ICE3PCS01G**

**EiceDRIVER™**  
**2EDN7524F**

# Main power board schematic

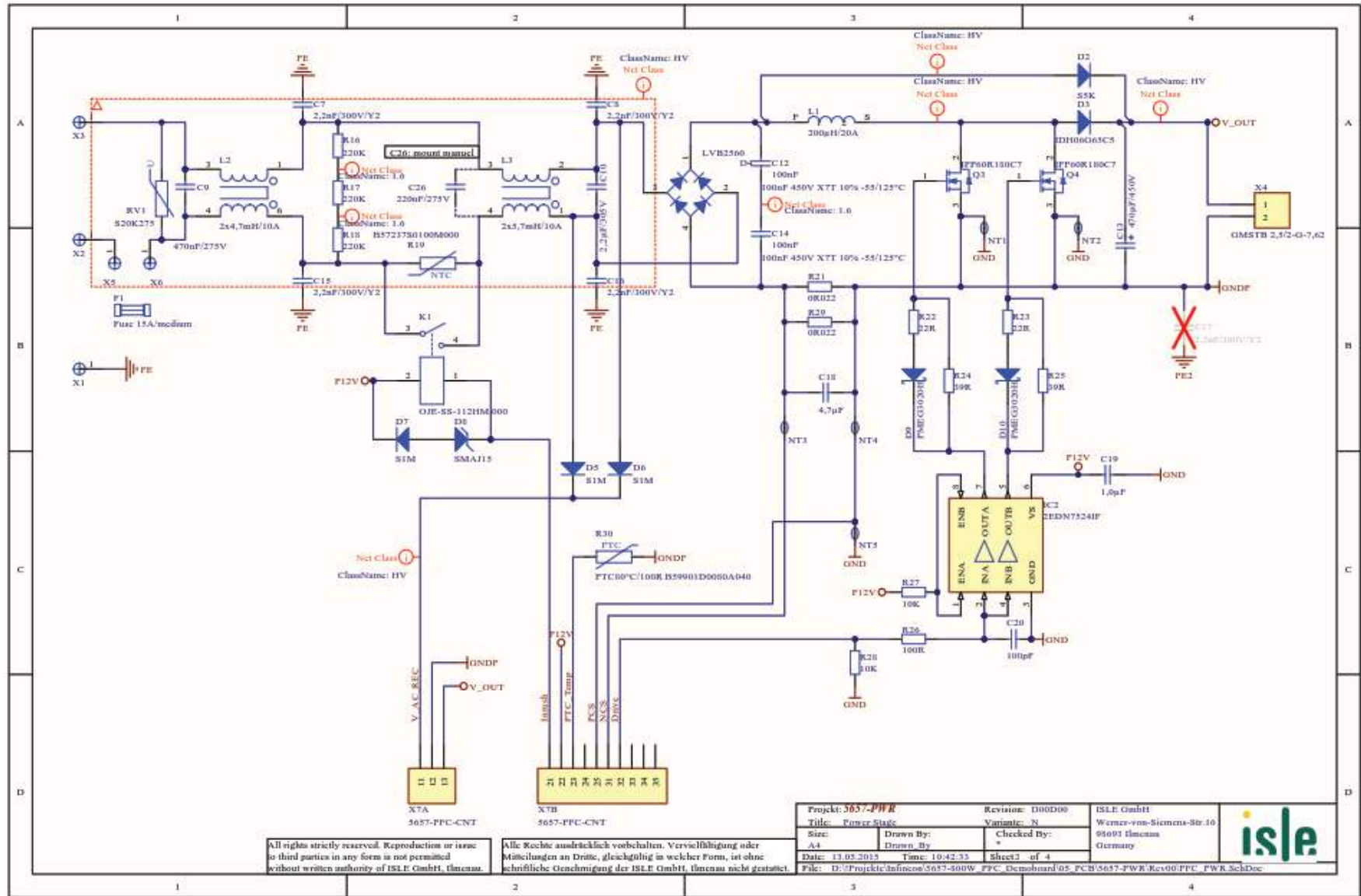

All rights strictly reserved. Reproduction or issue to third parties in any form is not permitted without written authority of ISLE GmbH, Ilmenau.

Alle Rechte ausdrücklich vorbehalten. Vervielfältigung oder Mängelungen an Dritte, gleichgültig in welcher Form, ist ohne schriftliche Genehmigung der ISLE GmbH, Ilmenau nicht gestattet.

Projekt: 5657-PWR		Revision: D00D00	ISLE GmbH Werner-von-Siemens-Str.10 95601 Ilmenau Germany	
Title: Power Stage		Variant: N		
Size: A4	Drawn By: Driven By: *	Checked By: *		
Date: 11.03.2015	Time: 10:42:33	Sheet: 3 of 4		
File: D:\Projekt\infineon\5657-300V_PFC_Demo\board\05_PCB\5657-PWR_Kvc00_PFC_PWR_SchDoc				

# Bias board schematic

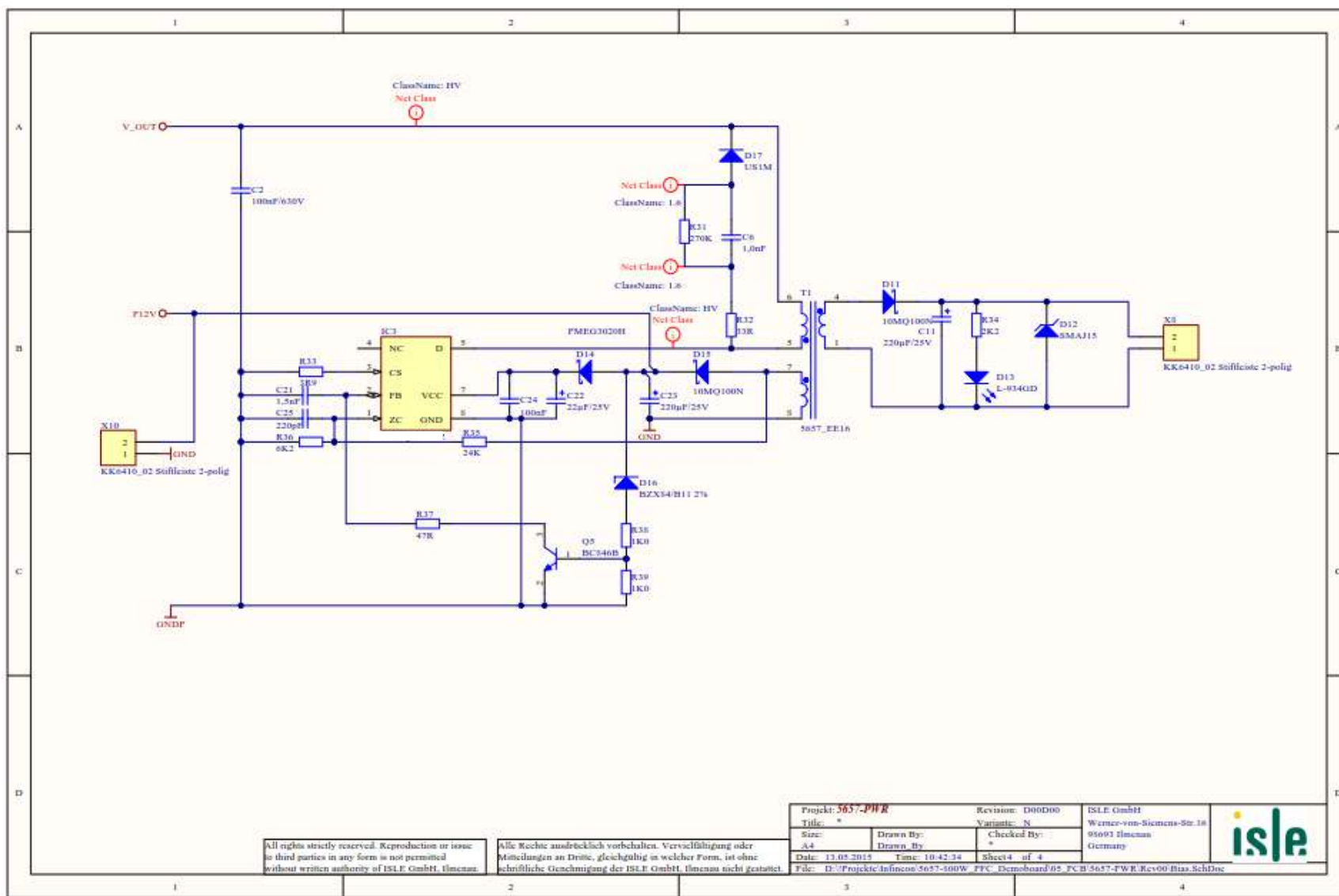

All rights strictly reserved. Reproduction or issue to third parties in any form is not permitted without written authority of ISLE GmbH, Ilmenau.

Alle Rechte ausdrücklich vorbehalten. Vervielfältigung oder Mitteilungen an Dritte, gleichgültig in welcher Form, ist ohne schriftliche Genehmigung der ISLE GmbH, Ilmenau nicht gestattet.

Project: 5657-FWR	Revision: D00D00	ISLE GmbH
Title: *	Variant: N	Werner-von-Siemens-Str.18
Size: A4	Drawn By: *	Checked By: *
Date: 13.05.2015	Time: 10:42:34	Sheet: 4 of 4
File: D:\Projekte\Infineon\5657-500W_FFC_DemoBoard\05_FCB\5657-FWR_Rev00_Bias_SchDoc		



# Digital control board schematic

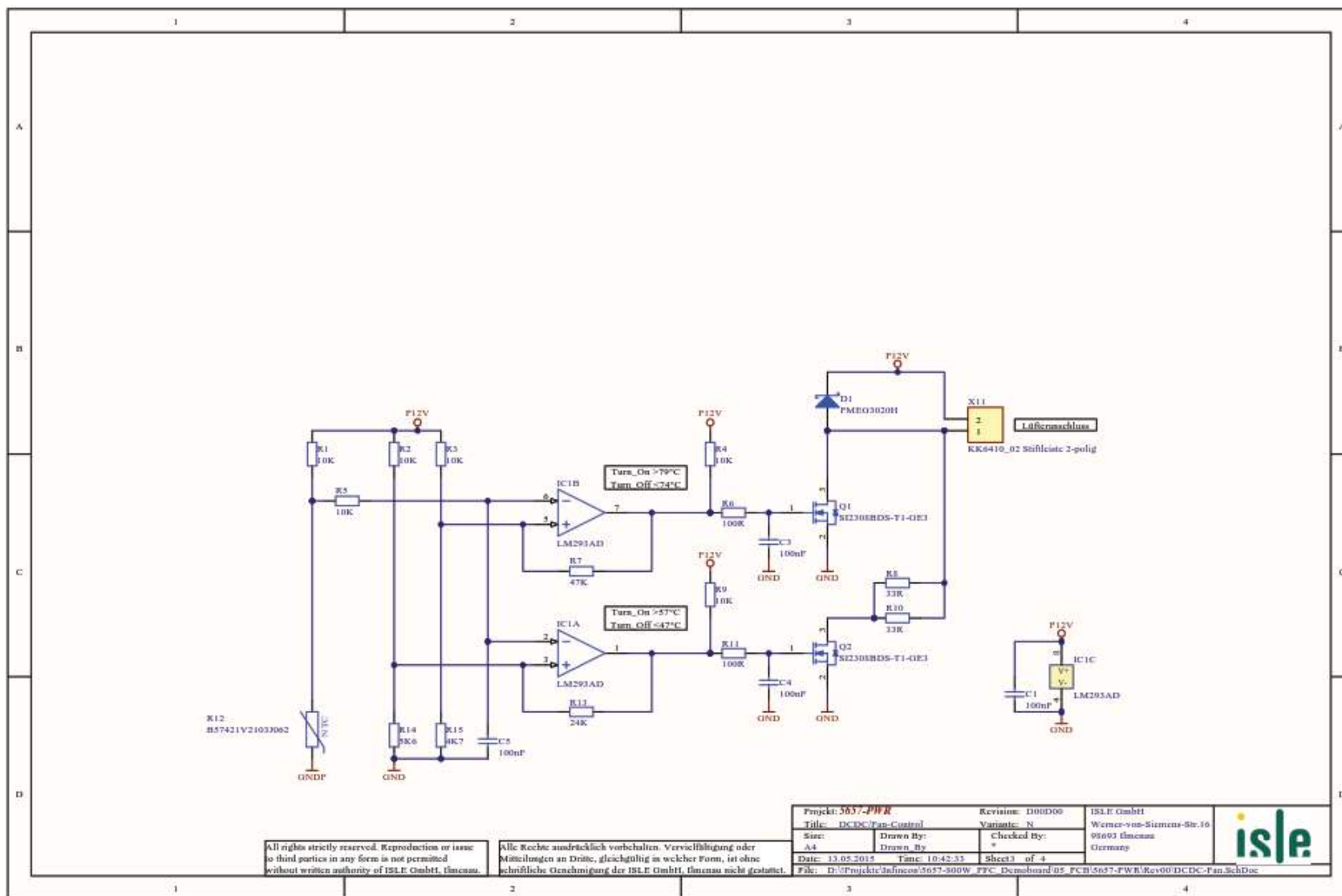

All rights strictly reserved. Reproduction or issue to third parties in any form is not permitted without written authority of ISLE GmbH, Ilsecau.

Alle Rechte ausdrücklich vorbehalten. Vervielfältigung oder Mitteilungen an Dritte, gleichgültig in welcher Form, ist ohne schriftliche Genehmigung der ISLE GmbH, Ilsecau nicht gestattet.

Projekt: 5637-FWR		Revision: D00008	ISLE GmbH
Titel: DCDC/Fan-Control		Variante: N	Werner-von-Siemens-Str.16
Size: A4	Drawn By: *	Checked By: *	09093 Ilsecau
Date: 13.05.2015	Time: 10:42:33	Sheet 3 of 4	Germany
File: D:\Projekte\Infineon\5637-300W_FFC_DemoBoard\05_FCB\5637-FWR\Rev00\DCDC-Fan_SchDoc			





# PFC control schematic

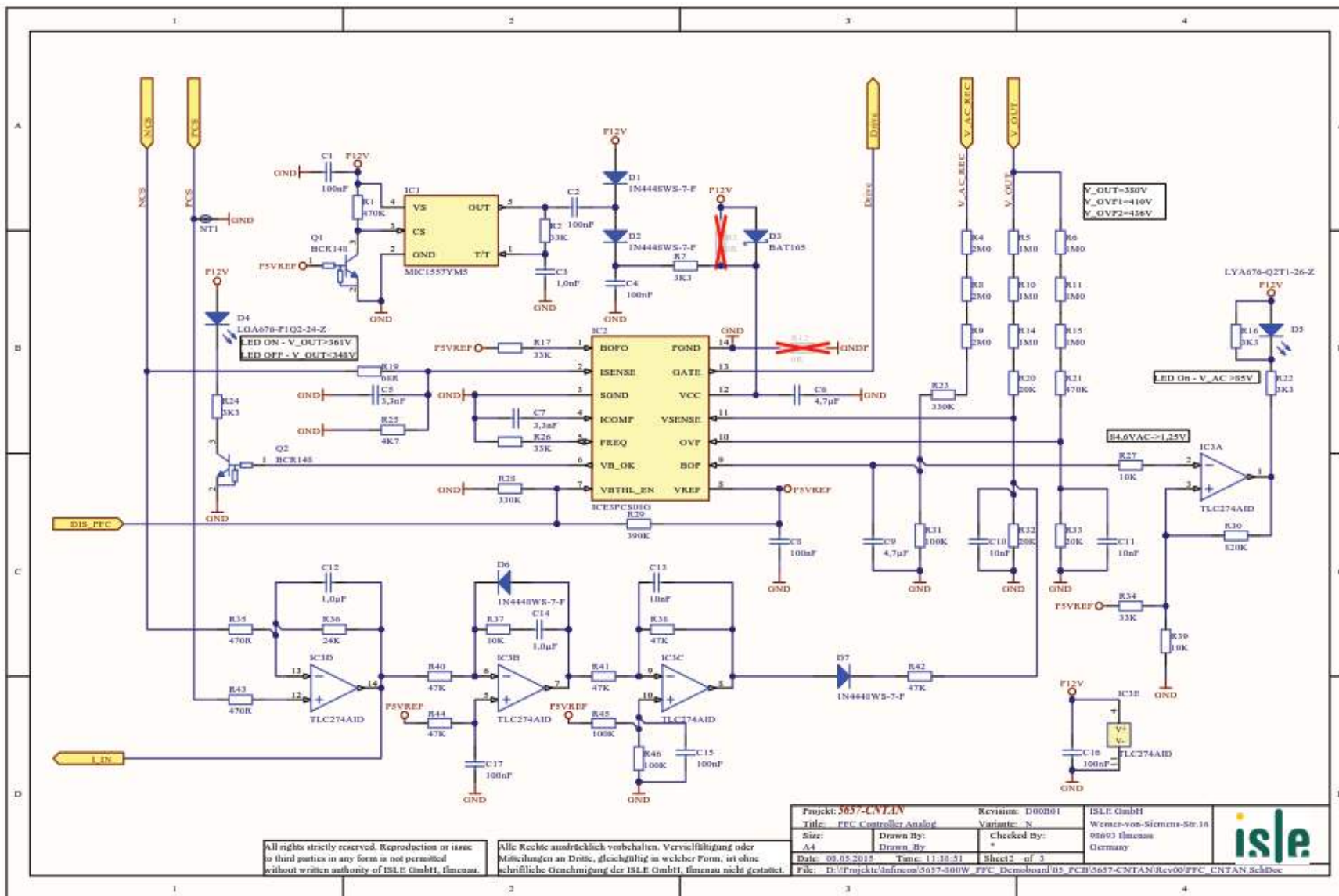

All rights strictly reserved. Reproduction or issue to third parties in any form is not permitted without written authority of ISLE GmbH, Ilmenau.

Alle Rechte ausdrücklich vorbehalten. Vervielfältigung oder Mächtigungen an Dritte, gleichgültig in welcher Form, ist ohne schriftliche Genehmigung der ISLE GmbH, Ilmenau nicht gestattet.

Projekt: 5657-CNTAN	Revisiune: D00001	ISLE GmbH
Title: PFC Controller Analog	Variante: N	Werner-von-Siemens-Str.16
Size: A4	Drawn By: *	01091 Ilmenau
Date: 09.05.2015	Time: 11:38:51	Germany
File: D:\Projekte\Infineon\5657-300W_PFC_DemoBoard\05_PCB\5657-CNTAN\Rev00\PFC_CNTAN_SchDec	Sheet 2 of 3	



# Temperature monitoring and inrush relay control schematic

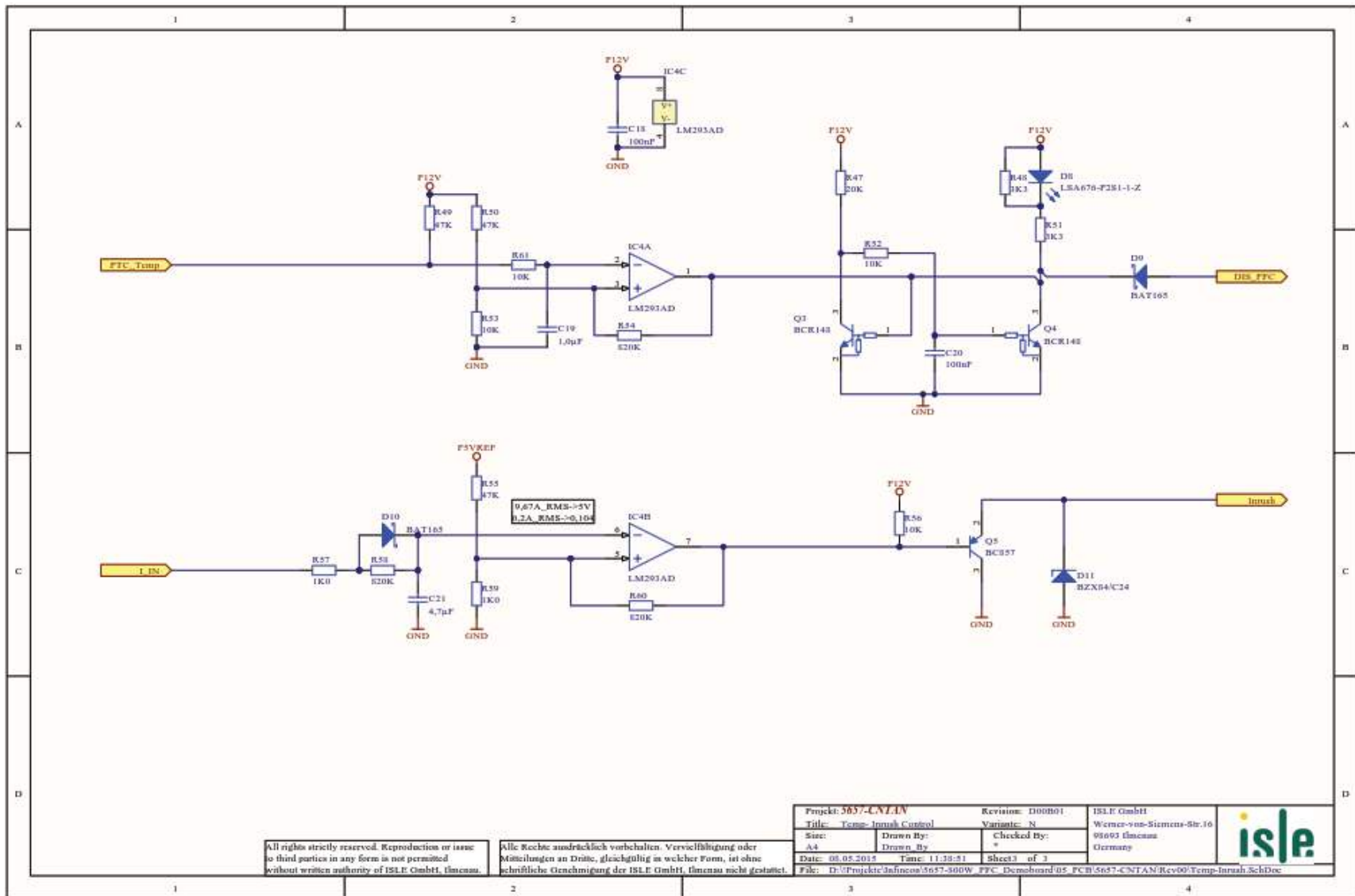

# PCB layout

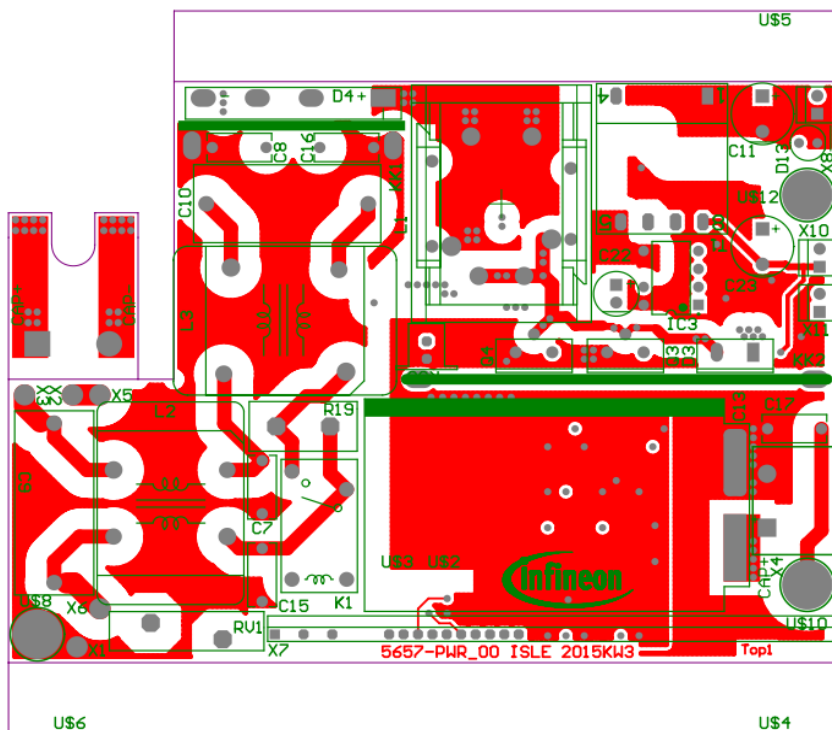

Top layer

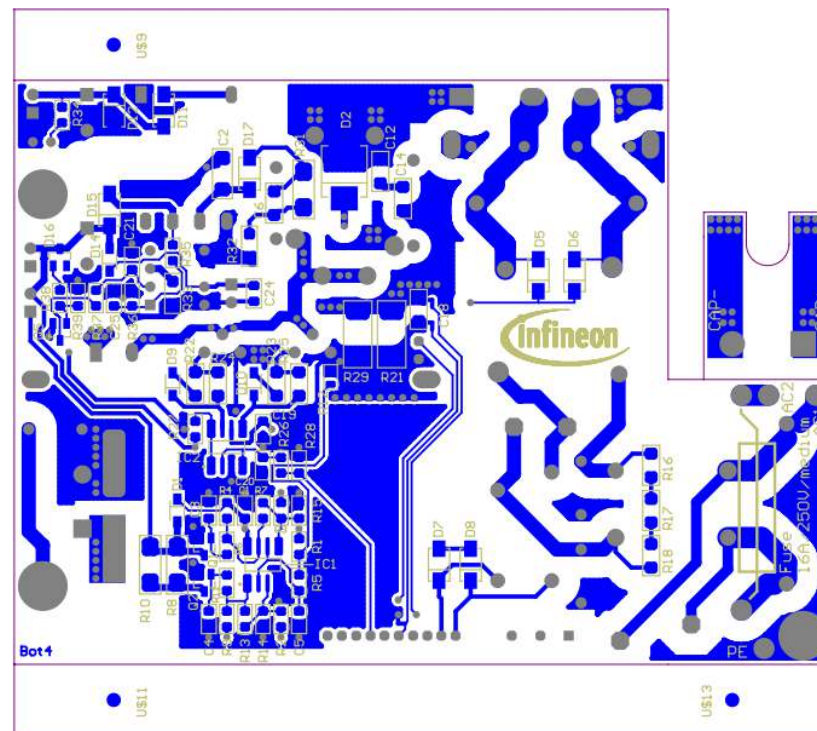

Bottom layer

# Table of contents

1

General description

2

Test results

3

Design concept

# Requirements

Parameter	Value
<b>Input requirements</b>	
Input voltage range, $V_{in\_range}$	90 V <sub>AC</sub> –265 V <sub>AC</sub>
Nominal input voltage, $V_{in}$	230 V <sub>AC</sub>
AC line frequency range, $f_{AC}$	47–64 Hz
Max peak input current, $I_{in\_max}$	10 A <sub>RMS</sub> @ $V_{in} = 90 V_{AC}$ , $P_{out\_max} = 800 W$ , Max load
Turn on input voltage, $V_{in\_on}$	80 V <sub>AC</sub> – 87 V <sub>AC</sub> , ramping up
Turn off input voltage, $V_{in\_off}$	75 V <sub>AC</sub> – 85 V <sub>AC</sub> , ramping down
Power Factor Correction (PFC)	Shall be greater than 0.95 from 20% rated load and above
Hold up time	10 ms after last AC zero point @ $P_{out\_max} = 800 W$ , $V_{out\_min} = 320 V_{DC}$
<b>Output features</b>	
Nominal output voltage, $V_{out}$	380 V <sub>DC</sub>
Maximum output power, $P_{out}$	800 W
Maximum output current, $I_{out\_max}$	2.1 A
Output voltage ripple	Max 20 V <sub>pk-pk</sub> @ $V_{out}$ , $I_{out}$
Output OV threshold maximum	450 V <sub>DC</sub>
Output OV threshold minimum	420 V <sub>DC</sub>

# Efficiency

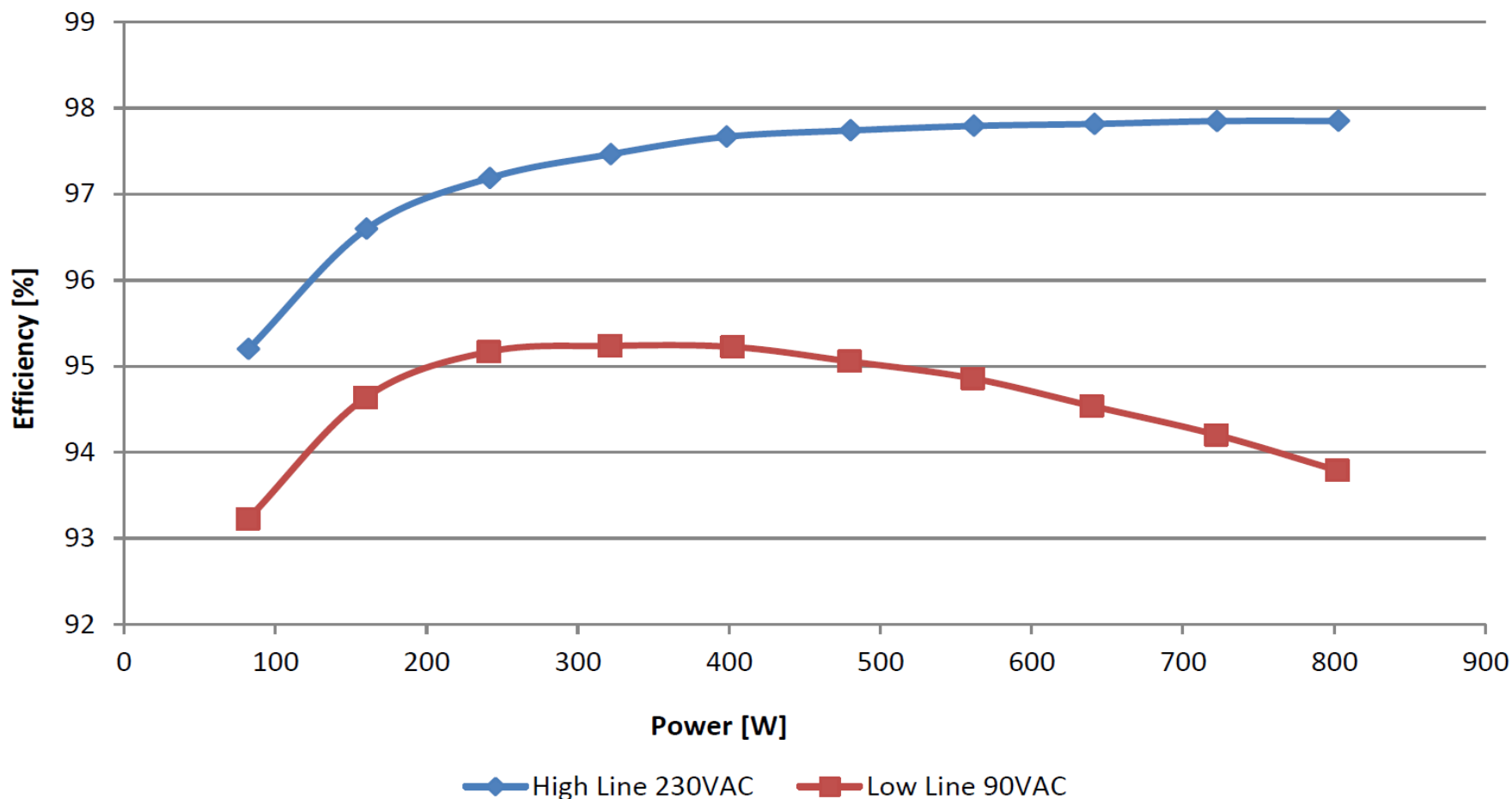

High Line and Low Line efficiency

2x IPP60R180C7 @  $f_s = 130 \text{ kHz}$ ,  $R_{\text{gate(on)}} = 39 \ \Omega$ ,  $R_{\text{gate(off)}} = 14 \ \Omega$

\*Fan powered externally with +12V and running at full speed

# Table of contents

1

General description

2

Test results

3

Design concept

# Power Factor Correction (PFC)

Power Factor Correction (PFC) shapes the input current of the power supply to be in synchronization with the mains voltage, in order to maximize the real power drawn from the mains. In a perfect PFC circuit, the input current follows the input voltage as a pure resistor, without any input current harmonics.

This document is to demonstrate the design and practical results of an 800 W 130 kHz platinum server PFC demo board based on Infineon Technologies devices in terms power semiconductors, non-isolated gate drivers, analog and digital controllers for the PFC converter as well as flyback controller for the auxiliary supply.

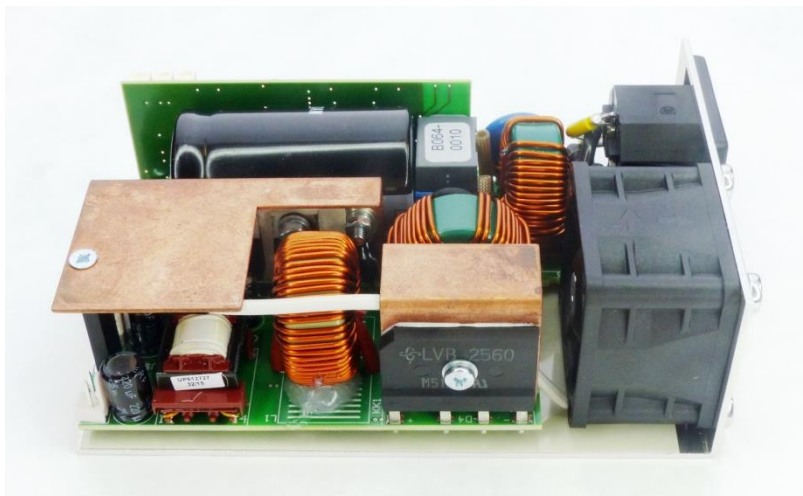



# Topology of the boost converter

Although active PFC can be achieved by several topologies, the boost converter is the most popular topology used in server PFC applications, for the following reasons:

- › The line voltage varies from zero to some peak value typically 375 V; hence a step up converter is needed to output a DC bus voltage of 380 V or more. For that reason the buck converter is eliminated, and the buck-boost converter has high switch voltage stress ( $V_{in} + V_o$ ), therefore it is also not the popular one
- › The boost converter has the filter inductor on the input side, which provides a smooth continuous input current waveform as opposed to the discontinuous input current of the buck or buck-boost topology. The continuous input current is much easier to filter, which is a major advantage of this design because any additional filtering needed on the converter input will increase the cost and reduces the power factor due to capacitive loading of the line

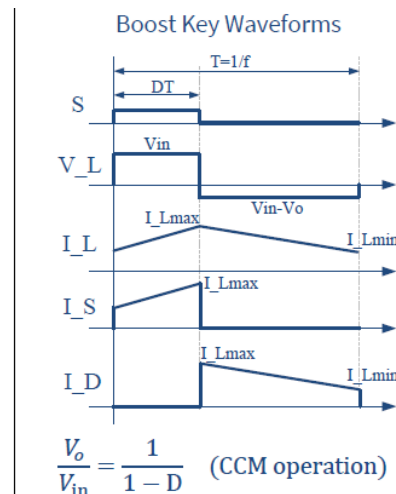
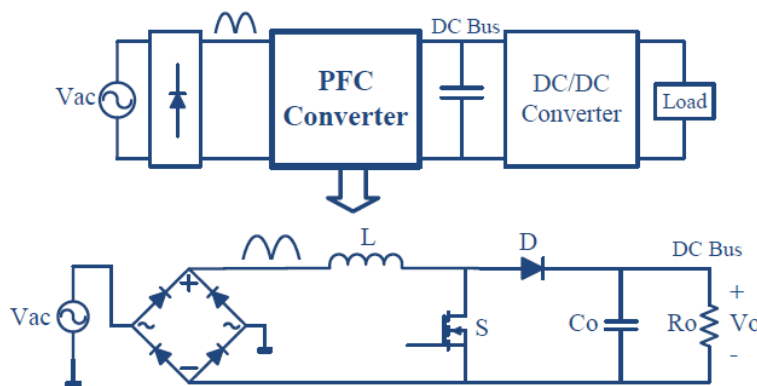

Structure and key waveforms of a boost converter

# PFC modes of operation

The boost converter can operate in three modes: Continuous Conduction Mode (CCM), Discontinuous Conduction Mode (DCM), and Critical Conduction Mode (CrCM). Figure 2 shows modeled waveforms to illustrate the inductor and input currents in the three operating modes, for the same exact voltage and power conditions. By comparing DCM among the others, DCM operation seems simpler than CrCM, since it may operate in constant frequency operation; however DCM has the disadvantage that it has the highest peak current compared to CrCM and also to CCM, without any performance advantage compared to CrCM. For that reason, CrCM is a more common practice design than DCM, therefore, this document will exclude the DCM design.

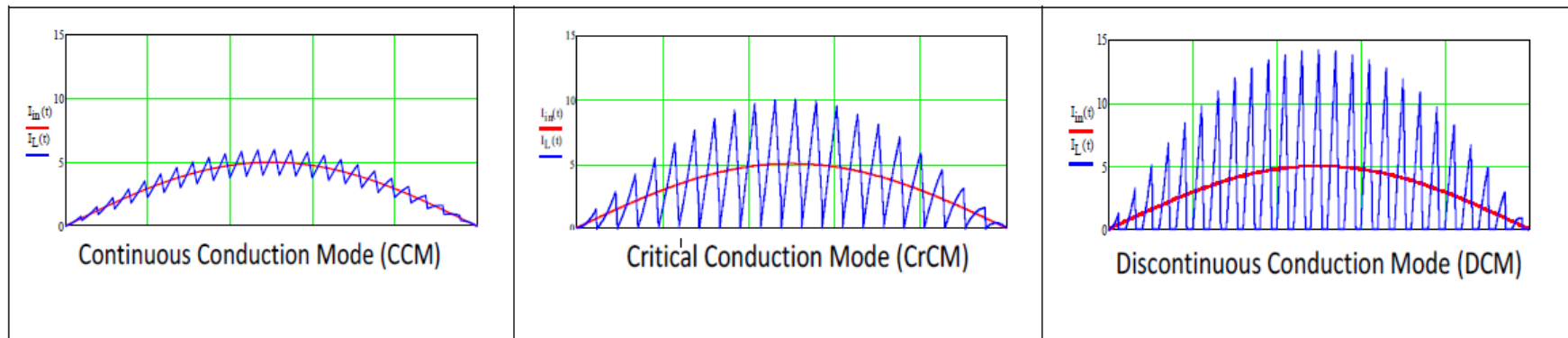

PFC inductor and input line current waveforms in the three different operating modes

# EMI filter

The EMI filter implemented is as a two-stage filter, which provides sufficient attenuation for both Differential Mode (DM) and Common Mode (CM) noise.

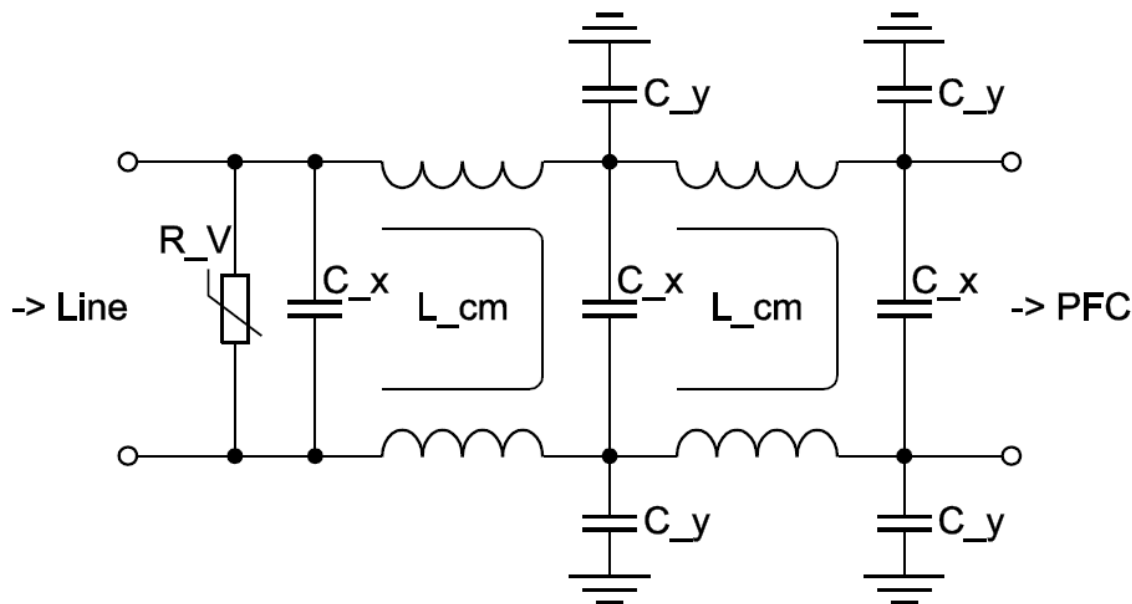

The two high current common mode chokes  $L_{cm}$  are based on high permeability toroid ferrite cores.

1. 2 x 26 Turns/ 2 x 4,76 mH
2. 2 x 28 Turns/ 2 x 5,7 mH

The relatively high number of turns causes a considerable amount of stray inductance, which ensures sufficient DM attenuation.

# Rectifier bridge

The rectifier bridge is designed for the worst case: maximum output power and minimum input voltage. To calculate the input current, an efficiency of 94% (at  $V_{in} = 90\text{ V}$ ) is applied.

Maximum rms value of the input current:

$$I_{INrms} = \frac{P_{OUTmax}}{\eta V_{INrms}} = \frac{800W}{0,94 \cdot 90V} = 9,46A$$

Maximum rms value of the diode current:

$$I_{Drms} = \frac{I_{INrms}}{2} = 4,73A$$

Maximum average value of the diode current:

$$I_{Davg} = \frac{\sqrt{2}I_{INrms}}{\pi} = 4,26A$$

Conduction losses of a rectifier diode:

$$P_D = I_{Davg} \cdot V_D + (I_{Drms})^2 \cdot r_D = 4,26A \cdot 0,5V + (4,73A)^2 \cdot 0,016\Omega = 2,49W$$

Total losses of the rectifier:

$$P_{REC} = 4P_D = 4 \cdot 2,49W = 9,96W$$

# PFC choke

The PFC choke design is based on a toroid high performance powder core. Toroid chokes allow well balanced and minimized core and winding losses, having a homogeneous heat distribution w/o hot spots and a large surface area. Hence they are predestined for systems which are targeting highest power density with forced air convection. Thereby very small choke sizes are feasible.



The core material was chosen to be a 60  $\mu$  Chang Sung Corporation's (CSC) HIGH FLUX, which has an excellent DC bias and good core loss behavior.

The outer diameter of the magnetic powder toroidal core is 27 mm.

The winding was implemented using enameled copper wire AWG 16 (1.25 mm diameter) with 60 turns.

# Support slides 800 W 130 kHz platinum server design

## Evaluation board page

- > Technical description
- > Datasheets
- > Parameters
- > Related material
- > Videos

The screenshot shows the Infineon website page for the 'EVAL\_800W\_PFC\_C7\_V2' evaluation board. The page is titled 'EVAL\_800W\_PFC\_C7\_V2' and includes a navigation menu with options like 'Products', 'Applications', 'Tools', 'Über Infineon', and 'Karriere'. The main content area is divided into sections: 'Übersicht', 'Parameter', 'Diagramme', 'Dokumentation', 'Bestellen', 'Bauzeit', 'Software', 'Index', 'Packaging', 'Lösungen', and 'Support'. A 'Summary of Features' section lists: Output voltage 12V, Output current 50A, Peak efficiency @ 50% load = 97.2%, and Efficiency @ 10% load = 95%. Below this, there are sections for 'Benefits', 'The following variants are available', and 'Target Applications'. A 'Solution Finder' tool is also visible on the right side of the page.

## EVAL\_800W\_PFC\_C7\_V2

## Product family pages

- > Product brief
- > Application notes
- > Selection guides
- > Datasheets and portfolio
- > Videos
- > Simulation models

The screenshot shows the Infineon website page for the '800V CoolMOS™ P6' product family. The page is titled '800V CoolMOS™ P6' and includes a navigation menu with options like 'Products', 'Applications', 'About Infineon', and 'Careers'. The main content area is divided into sections: 'Support', 'Where to buy', 'Download Service', 'Power Management Solutions', 'Product Brief 800V CoolMOS™ P6', 'Application Note 800V CoolMOS™ P6', 'Related Links', 'Power MOSFET Reliability Data', 'Power MOSFET Reliability Data', 'Power MOSFET Reliability Data', and 'Power MOSFET Reliability Data'. The page also features a 'Support' section with various links and a 'Where to buy' section.

- > [IPP60R180C7](#)
- > [IDH06G65C5](#)
- > [ICE3PCS01G](#)
- > [2EDN7524F](#)
- > [XMC 1400](#)
- > [ICE2QR2280Z](#)





Part of your life. Part of tomorrow.

