



QorIQ Qonverge Platform

QorIQ Qonverge BSC9131 and BSC9132 System on Chip Devices

Smart Grid

- Power relays
- Power protection
- Uninterruptible power supplies

Aerospace and Defense

- JTRS
- Smart munitions
- Unmanned vehicles
- Software-defined radio

Industrial

- Factory automation
- Image analytics

Enterprise

- Voice gateways/PBX
- Video gateways

A new dimension in GPP and DSP integration

Overview

The QorIQ Qonverge BSC9131 and BSC9132 processors are highly integrated System on Chip (SoC) devices targeting network-connected industrial nodes and other systems requiring the computational power of a digital signal processor not met by off the shelf solutions today. The two devices combine 1-2 e500 cores, built on Power Architecture® technology and 1-2 StarCore SC3850 DSP cores, each running up to 1.2 GHz with a rich set of peripherals. The SoCs feature our trust architecture, which builds a fortress of on-chip security with tamper protection, secure boot and isolation of cores, in addition to cryptographic acceleration engines for secure off-chip communications. The BSC9131 and BSC9132 SoCs also offer the integration of IEEE® 1588v2 on dual Ethernet ports, enabling time stamping and redundancy for various industrial networking applications.

The integration of processing cores provides the advantages of reducing required board space, memory chip count and power by up to 50% versus discrete processing solutions. In addition, the specialized processing of heterogeneous cores can allow you to move from expensive ASIC designs to a more programmable, off-the-shelf solution and, as part of the larger QorIQ family, the BSC9131 and BSC9132 SoCs software compatible with more than 100 other Freescale communications processors, giving you the ability to reuse code and protect your software

QorIQ Qonverge BSC9132 SoC Block Diagram

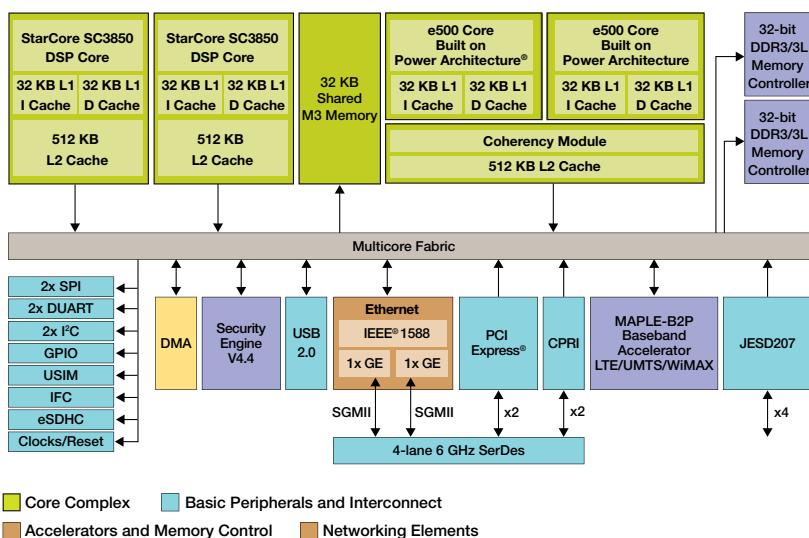

research and design investment. The BSC9131 and BSC9132 SoCs also include the MAPLE block for hardware acceleration of common DSP functions such as fast Fourier transform, discrete Fourier transform and turbo Viterbi decoding.

The QorIQ Qonverge line of products has a proven set of hardware and software tools for code development and debug. The CodeWarrior Development Studio is a comprehensive integrated development environment (IDE) that provides a highly visual and automated framework to accelerate the development of the most complex embedded applications. The CodeWarrior tools allow a consistent look and feel for developing code on both cores as opposed to competing solutions that may require multiple debugging platforms. In addition to the IDE, the BSC9131RDB and BSC9132QDS give you the ability to develop and test code on hardware systems before developing your own hardware solution.



QorIQ Qonverge BSC9131 Reference Design Board



QorIQ Qonverge BSC9132 Development Board



QorIQ Qonverge BSC9131 SoC Block Diagram

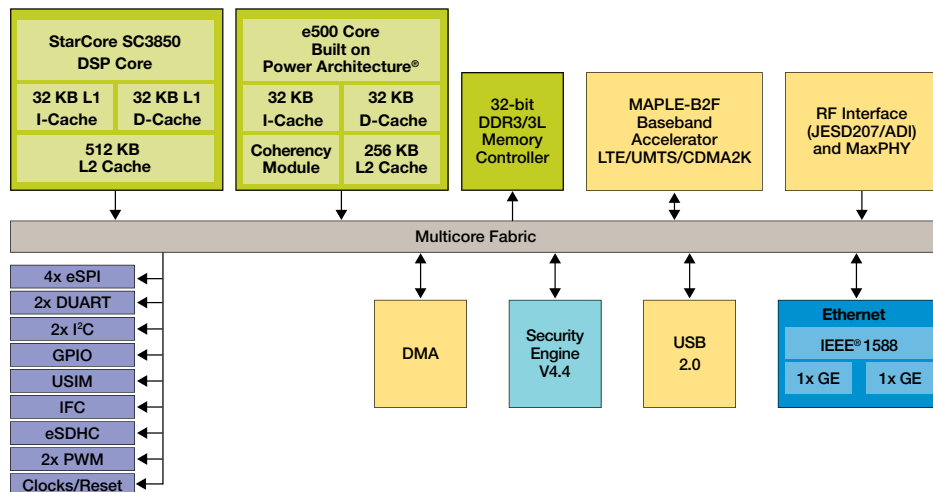

QorIQ Qonverge BSC9131 and BSC9132 Comparison Chart

	BSC9131	BSC9132
GPP	1 x e500, 256 KB L2 up to 1 GHz	2 x e500, 512 KB shared L2 up to 1.2 GHz
DSP/Starcore	1 x SC3850 with 512 KB L2 cache up to 1 GHz	2 x SC3850 each with 512 KB L2 cache, up to 1.2 GHz
DSP hardware accelerators	1 x MAPLE B2F array FFT, convolution, Viterbi Turbo, Filtering, CRC	1 x MAPLE B2P array FFT, convolution, Viterbi Turbo, Filtering, CRC
Memory	1 x DDR3, 32-bit (16-bit mode only with ECC), up to 800 MHz	2 x DDR3, 32-bit (40-bit including ECC), up to 1333 MHz
Flash	NOR, NAND and FPGA integrated	NOR, NAND and FPGA integrated
Trust architecture secure boot	Yes	Yes
SEC hardware encryption	SEC v4.4	SEC v4.4
Pulse width modulators	2	2
GigE with integrated 1588v2	2	2
USB	1 x 2.0	1 x 2.0
PCIe	No	Yes
TDM	1	2
CPRI	No	Yes
JESD207	3: - 2 dual, 1 single lane	4: - 3 dual, 1 single lane
Other interfaces	UART, SPI, eSDHC, USIM, and I ² C controller	UART, SPI, eSDHC, USIM, and I ² C controller

For more information about the QorIQ Qonverge BSC series, visit freescale.com/QorIQQonverge

Freescale, the Freescale logo, CodeWarrior, QorIQ, QorIQ Qonverge and StarCore are trademarks of Freescale Semiconductor, Inc., Reg. U.S. Pat. & Tm. Off. All other product or service names are the property of their respective owners.
© 2014 Freescale Semiconductor, Inc.

Document Number: BSC913xNW Rev 0