



# TAOGLAS®



# Datasheet

**CAB.A02**

**Description:**

SMA(F) Bulkhead Straight Jack to 95mm of  $\varnothing 0.81\text{mm}$  IPEX MHFIII (W.FL Compatible)

**Features:**

- Cable Assembly
- SMA(F) Bulkhead Straight Jack
- IPEX MHFIII (W.FL Compatible)
- 95mm  $\varnothing 0.81\text{mm}$  cable
- RoHS & Reach Compliant

1. Introduction	3
2. Cable Specifications – RG-178	4
3. Cable Insertion Loss	6
4. Mechanical Drawing	7
5. Packaging	8
<hr/>	
Changelog	9

Taoglas makes no warranties based on the accuracy or completeness of the contents of this document and reserves the right to make changes to specifications and product descriptions at any time without notice. Taoglas reserves all rights to this document and the information contained herein.

Reproduction, use or disclosure to third parties without express permission is strictly prohibited.



## 1. Introduction



The Taoglas CAB.A02 is a 95mm  $\varnothing$ 0.81mm cable assembly with IPEX MHFIII (W.FL Compatible) and SMA Female Bulkhead Jack connectors.

Taoglas provides customized length and connector variants subject to MOQ. Contact your regional Taoglas customer support team for details.

## 2. Cable Specifications – RG-178

### 2.1 Cross Section

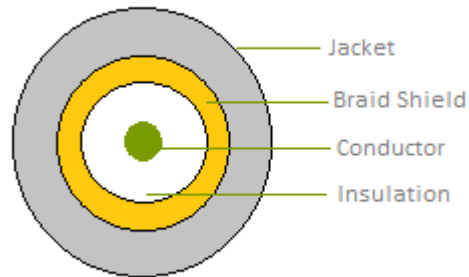

### 2.2 Cross Section

#### Structure and Dimensions

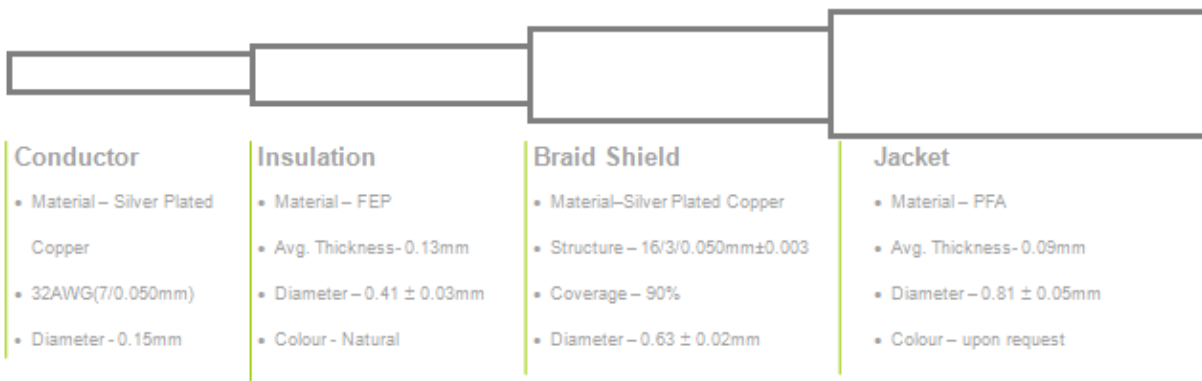

## 2.3 Cross Section

1	Rating Temp Voltage:	-40°C to 85°C	
2	Insulation Resistance:	1000 MEGA OHM-KM Min.	
3	Conductor Resistance:	1400 OHM/KM/20°C Max.	
4	Dielectric Strength:	AC 1.0 KV/minute	
5	Spark test:	2.5 KV	
6	Nom. Impedance	50 ± 3 Ohms	
7	Nom. Capacitance	97 ± 3 pF/m	
8	Standard Attenuation:	1GHz	3.6
		2GHz	5.1
		3GHz	6.2
		4GHz	7.5
		5GHz	8.5
		6GHz	9.4

### 3. Cable Insertion Loss

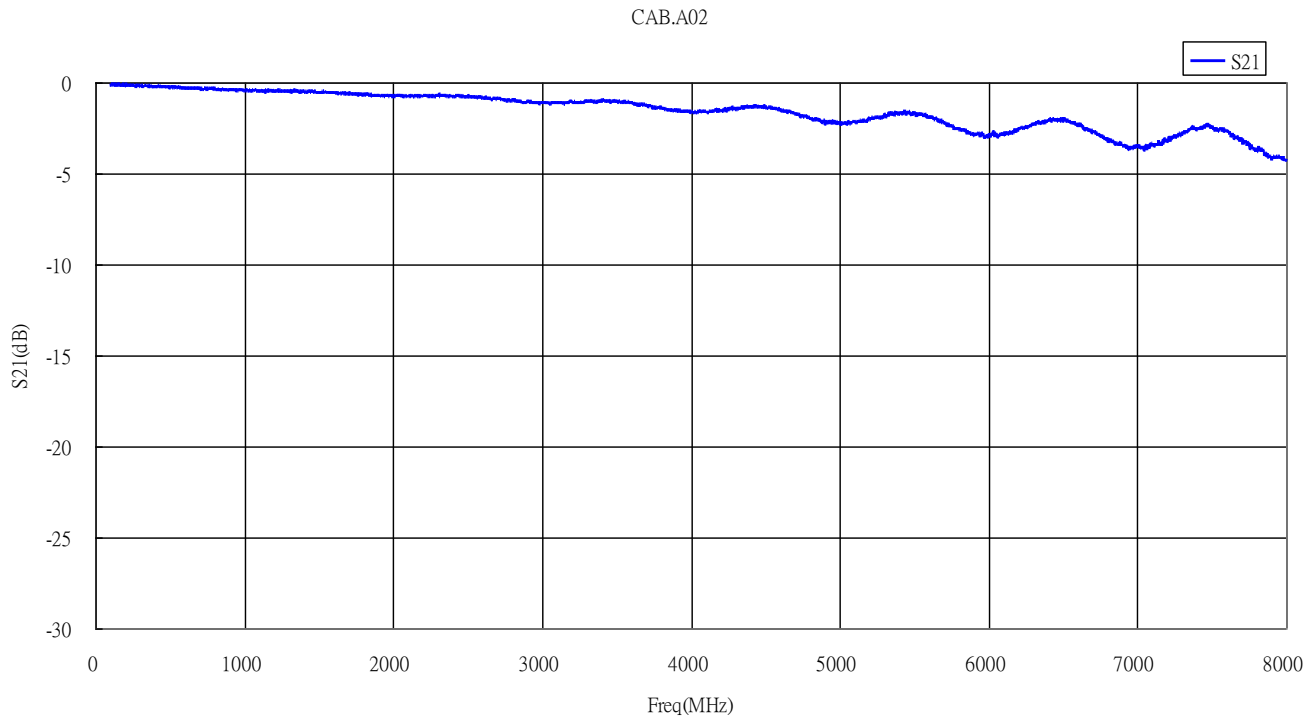

# 4. Mechanical Drawing (Units: mm)

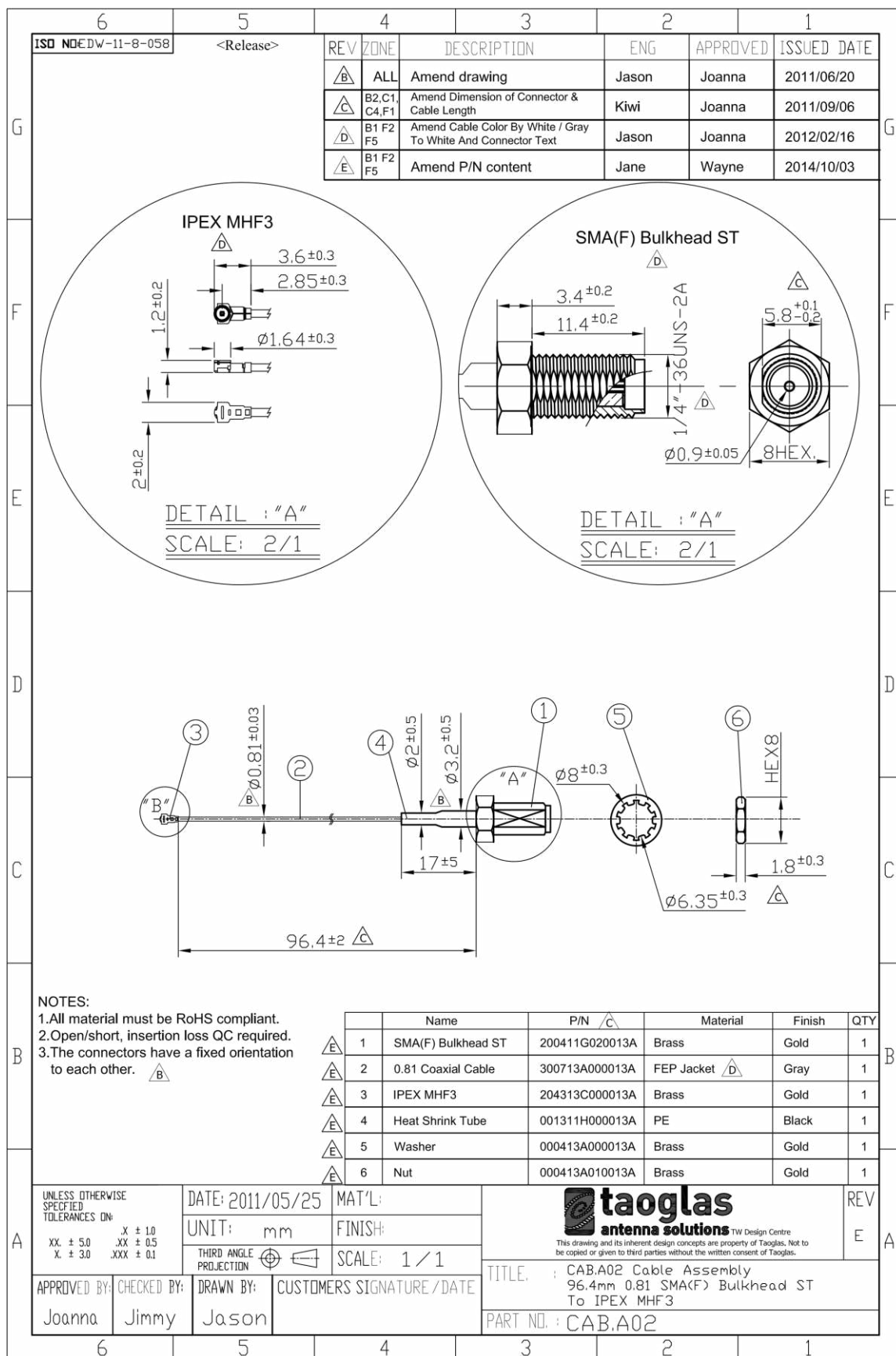

## 5. Packaging

100pcs CAB.A02 per PE Bag  
 Bag Dimension: 260\*150mm  
 Weight: 410g

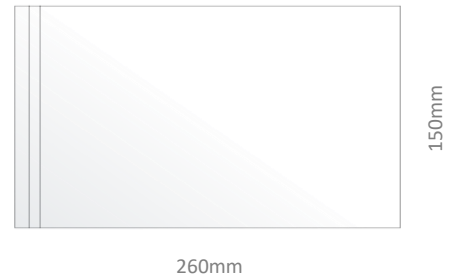

2000pcs CAB.A02 per Carton  
 Dimensions: 360\*310\*160mm  
 Weight: 8.5Kg

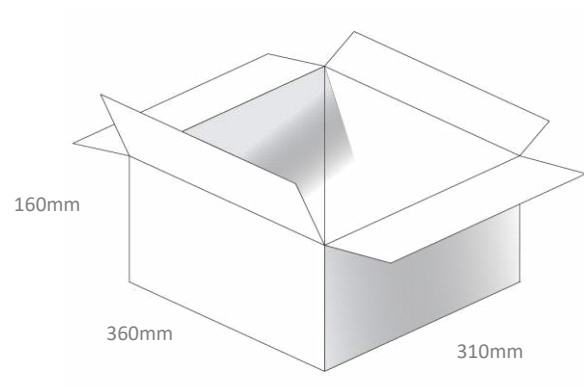



Changelog for the datasheet

**SPE-11-8-118 – CAB.A02**

<b>Revision: D</b>	
Date:	2020-02-13
Notes:	
Author:	Jack Conroy

**Previous Revisions**

<b>Revision: C</b>	
Date:	2015-08-04
Notes:	Added Hole Data
Author:	Jack Conroy

<b>Revision: B</b>	
Date:	2011-10-20
Notes:	
Author:	Aine Doyle

<b>Revision: A (Original First Release)</b>	
Date:	2011-10-14
Notes:	Initial Release
Author:	Aine Doyle

--	--

--	--

--	--

--	--

--	--

--	--

--	--



**TAOGLAS**®

[www.taoglas.com](http://www.taoglas.com)