



soberton inc.

# WSP WATER RESISTANT SPEAKER

Acoustic Product Specification

Product Number: WSP-5090



Release | Revision: A/2018

## CONTENTS

This document contains the technical specifications for the water resistant speaker

### Page 1

Specifications

Dimensions

Frequency Response

## Specifications

| Specification               | Unit         | WSP-5090   |
|-----------------------------|--------------|--|
| AC Impedance                | $\Omega$     | 8 $\pm$ 15% at 1000Hz  |
| Rated Input Power           | Watt         | 5.0  |
| Max Input Power             | Watt         | 6.0  |
| Resonant Frequency          | Hz           | 330 $\pm$ 20%  |
| Frequency Range             | Hz           | F0~19.0KHz, average SPL $\pm$ 10dB   |
| Output Sound Pressure Level | dB           | 91 $\pm$ 3dB<br>1.0 Watt/10 cm, AVG. at 0.8, 1.0, 1.2, 1.5KHz                                      |
| Operating Temperature       | $^{\circ}$ C | -20 $^{\circ}$ C ~ +50 $^{\circ}$ C  |
| Storage Temperature         | $^{\circ}$ C | -40 $^{\circ}$ C ~ +60 $^{\circ}$ C  |
| Dimension                   | mm           | 90.2 x 50.1 x H31.4  |
| Distortion                  |              | 3% maximum at 1000Hz, 5.0W   |
| Polarity                    |              | Diaphragm shall move forward when a positive DC current is applied to the "+" or "Marked" terminal |
| Load Test                   |              | Audio Signal Generator at 6.3 Volt<br>Total 48hrs and 20Hz ~ 20KHz resonant frequency              |
| Abnormal Sound Test         |              | Must be normal tested at 6.3 Volt sine wave  |
| Ingress Rating              |              | IP65   |

## Dimensions

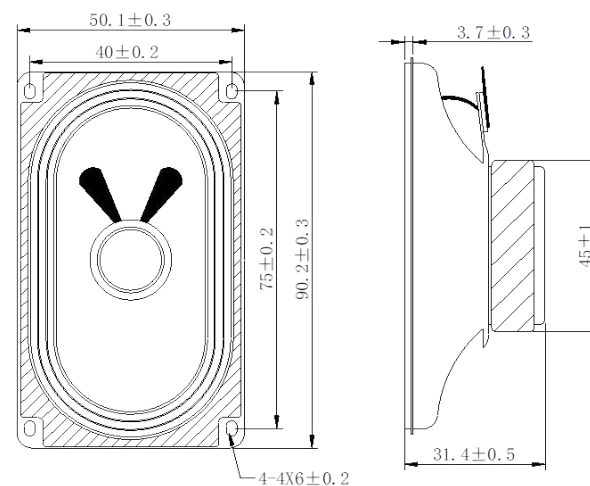

Unit: mm

## Frequency Response

