

7 Circuits Darlington Transistor Array

BA12003DF-Z BA12004DF-Z

General Description

BA12003DF-Z, BA12004DF-Z are darlington transistor array consist of 7circuits, input resistor to limit base current and output surge absorption clamp diode.

Packages

SOP-J16A

W(Typ) x D(Typ) x H(Max)

9.90mm x 6.00mm x 1.725mm

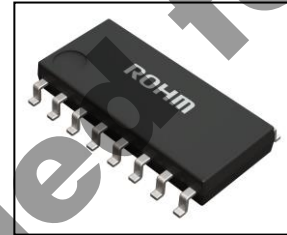

SOP-J16A
BA12003DF-Z / BA12004DF-Z

Features

- Built-in 7 circuits
- High output break down voltage
- High DC output current gain
- Built-in input resistor to limit base current
- Built-in output surge absorption clamp diode

Applications

- Motor Drivers
- LED Drivers
- Solenoid Drivers
- Low Side Switch

Key Specifications

- Output break down voltage : $V_{CE}=60V(\text{max})$
- Output current : $I_o=500\text{mA}/\text{ch}(\text{max})$
- Operating supply voltage range : $-0.5V$ to $+30V$
- Operating temperature range : -40°C to $+85^{\circ}\text{C}$
- DC current gain : $h_{fe}=1000(\text{min})$
- Input resistor : BA12003DF-Z $R_{in}=2.7\text{k}\Omega$
BA12004DF-Z $R_{in}=10.5\text{k}\Omega$

Typical Application Circuit

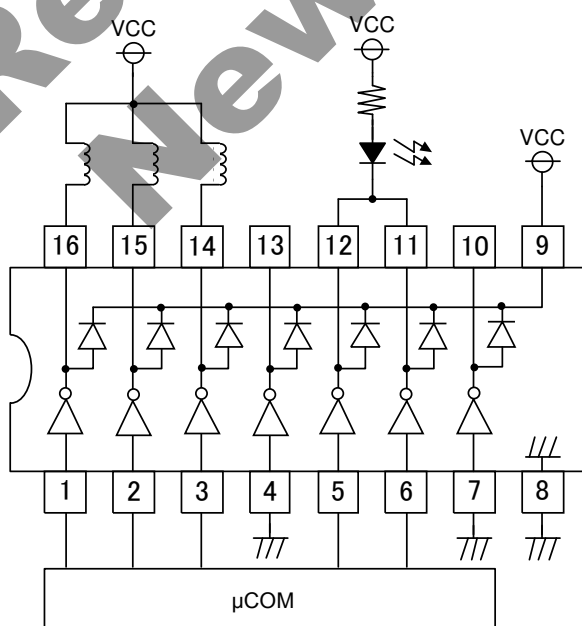

○Product structure: Silicon integrated circuit ○This product has not designed protection against radioactive rays

Pin Configuration

Block Diagram

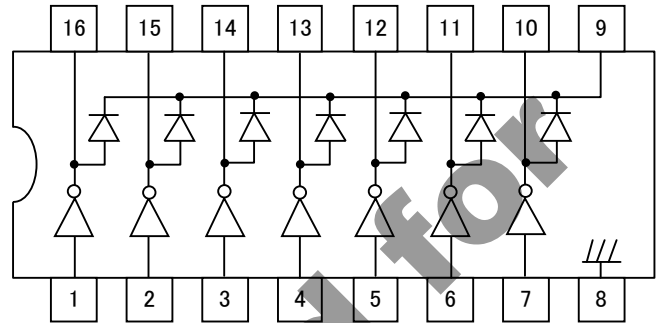
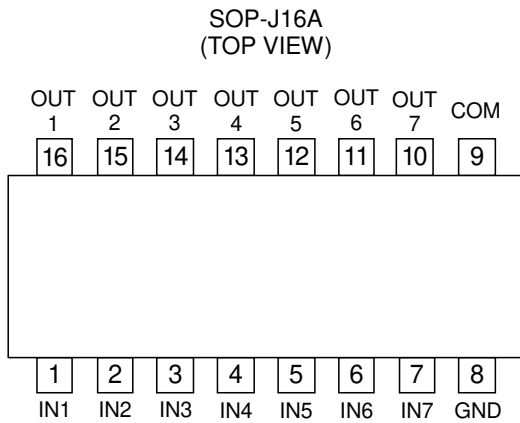

Pin Description

Pin No.	Pin Name	Function	Pin No.	Pin Name	Function
1	IN1	Input 1	9	COM	Clamp diode cathode
2	IN2	Input 2	10	OUT7	Output 7
3	IN3	Input 3	11	OUT6	Output 6
4	IN4	Input 4	12	OUT5	Output 5
5	IN5	Input 5	13	OUT4	Output 4
6	IN6	Input 6	14	OUT3	Output 3
7	IN7	Input 7	15	OUT2	Output 2
8	GND	Ground	16	OUT1	Output 1

I/O Equivalence Circuit

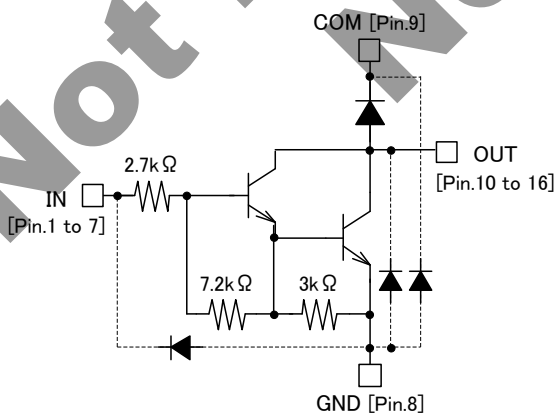

BA12003DF-Z

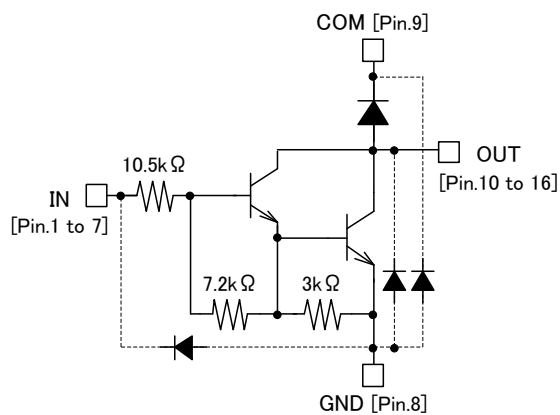

BA12004DF-Z

Note : The diode indicating the junction with a dotted line is a parasitic element.
 Note : The input and output parasitic diodes cannot be used as clamp diodes.

Absolute Maximum Ratings (T_A=25°C)

Parameter	Symbol	Rating	Unit
Output Voltage	V _{CE}	-0.5 to +60	V
Output Current	I _o	500	mA/circuit
Input Voltage	V _I	-0.5 to +30	V
Diode Reverse Voltage	V _R	60	V
Diode Forward Current	I _F	500	mA/ circuit
GND Terminal Current	I _{GND}	2.3(Note 1)	A
Operating Temperature	T _{opr}	-40 to +85	°C
Storage Temperature	T _{stg}	-55 to +150	°C

(Note 1) Pulse width≤20ms, Duty Cycle≤10%, 7 circuits flow the same current.

Caution: Operating the IC over the absolute maximum ratings may damage the IC. The damage can either be a short circuit between pins or an open circuit between pins and the internal circuitry. Therefore, it is important to consider circuit protection measures, such as adding a fuse, in case the IC is operated over the absolute maximum ratings.

Thermal Resistance (Note 1)

Parameter	Symbol	Thermal Resistance (Typ)		Unit
		1s ^(Note 3)	2s2p ^(Note 4)	
SOP-J16A				
Junction to Ambient	θ _{JA}	169.7	115.4	°C/W
Junction to Top Characterization Parameter ^(Note 2)	Ψ _{JT}	21	20	°C/W

(Note 1)Based on JESD51-2A(Still-Air)

(Note 2)The thermal characterization parameter to report the difference between junction temperature and the temperature at the top center of the outside surface of the component package.

(Note 3)Using a PCB board based on JESD51-3.

Layer Number of Measurement Board	Material	Board Size
Single	FR-4	114.3mm x 76.2mm x 1.57mmt

Top	
Copper Pattern	Thickness
Footprints and Traces	70μm

(Note 4)Using a PCB board based on JESD51-7.

Layer Number of Measurement Board	Material	Board Size
4 Layers	FR-4	114.3mm x 76.2mm x 1.6mmt

Top		2 Internal Layers		Bottom	
Copper Pattern	Thickness	Copper Pattern	Thickness	Copper Pattern	Thickness
Footprints and Traces	70μm	74.2mm x 74.2mm	35μm	74.2mm x 74.2mm	70μm

Electrical Characteristics (Unless otherwise specified, GND=0V T_A=25°C)

Parameter	Symbol	Limit			Unit	Conditions	Test Circuit	
		Min	Typ	Max				
Output Leakage Current	I _L	-	-	10	μA	V _{CE} =60V	1	
Output DC Current Gain	h _{FE}	1000	2400	-	-	V _{CE} =2.0V, I _O =350mA	2	
Output Saturation Voltage1	V _{CEsat1}	-	0.94	1.1	V	I _O =100mA, I _I =250 μA	2	
Output Saturation Voltage2	V _{CEsat2}	-	1.14	1.3	V	I _O =200mA, I _I =350 μA	2	
Output Saturation Voltage3	V _{CEsat3}	-	1.46	1.6	V	I _O =350mA, I _I =500 μA	2	
Input Voltage1	BA12003D	V _{I1}	2.0	-	-	V	V _{CE} =2.0V, I _O =100mA	3
	BA12004D		5.0	-	-			
Input Voltage2	BA12003D	V _{I2}	2.4	-	-	V	V _{CE} =2.0V, I _O =200mA	3
	BA12004D		6.0	-	-			
Input Voltage3	BA12003D	V _{I3}	3.4	-	-	V	V _{CE} =2.0V, I _O =350mA	3
	BA12004D		8.0	-	-			
Input Current	BA12003D	I _I	-	0.90	1.35	mA	V _I =3.85V	4
	BA12004D		-	0.39	0.5		V _I =5.0V	
Diode Reverse Current	I _R	-	-	50	μA	V _R =60V	5	
Diode Forward Voltage	V _F	-	1.73	2.0	V	I _F =350mA	6	
Input Capacity	C _I	-	30	-	pF	V _I =0V, f=1MHz	7	

Test Circuit

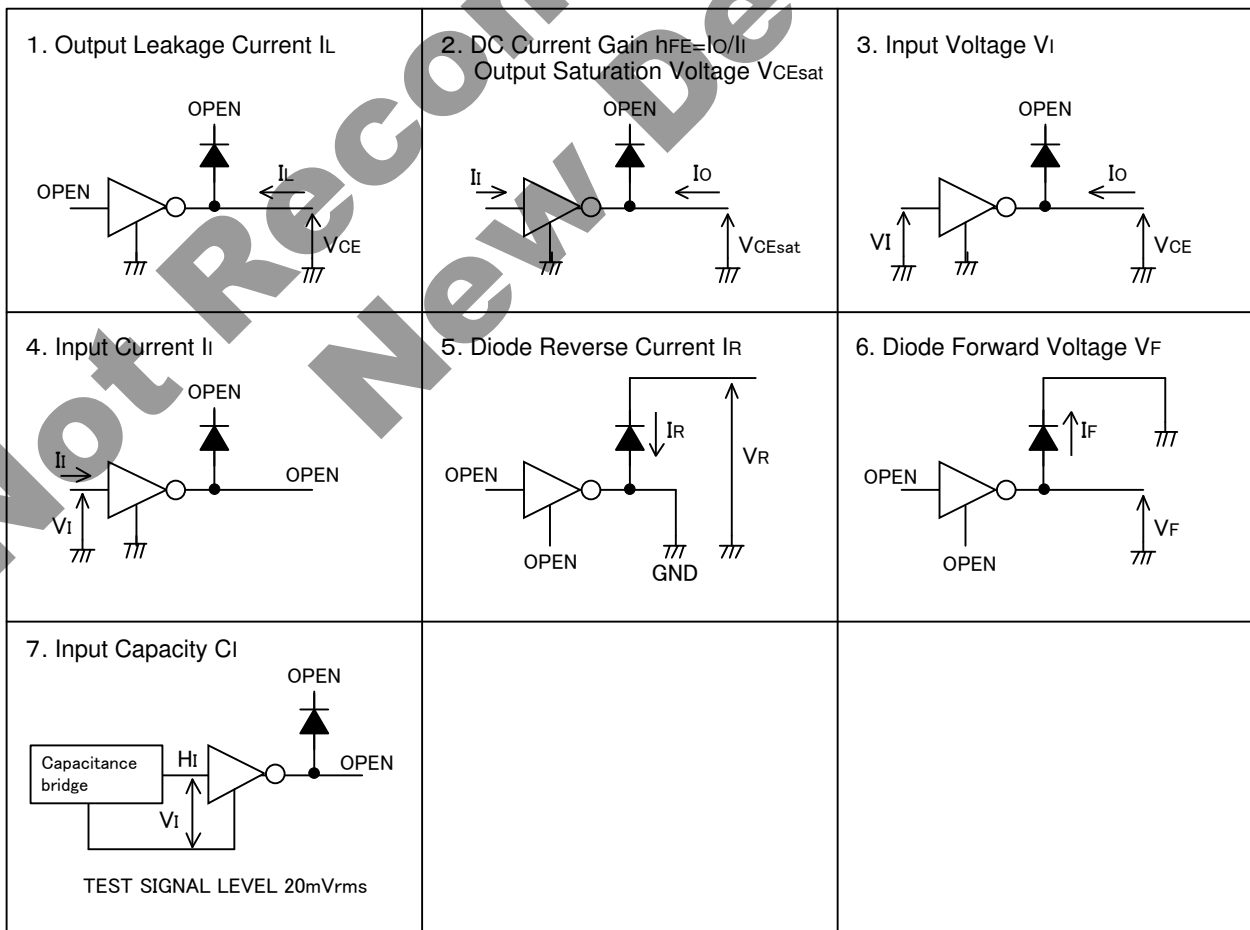

Typical Performance Curve (Reference Data)

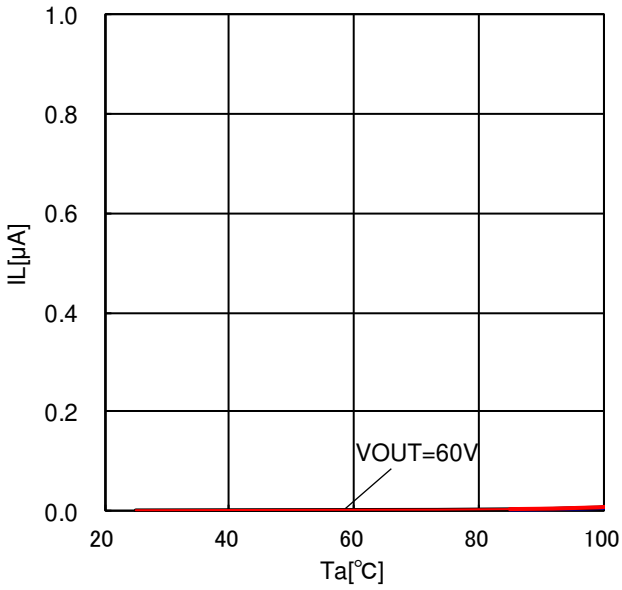

Figure 1 .
Output Leakage Current vs Ambient Temperature

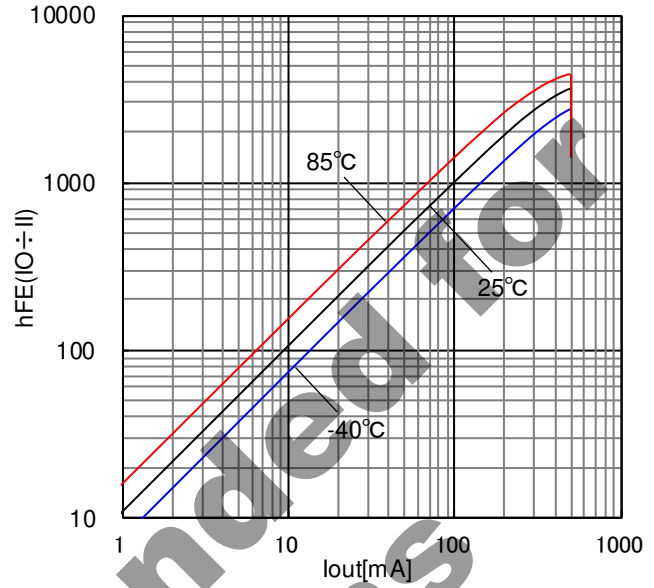

Figure 2 .
Output DC Current Gain vs Output Current

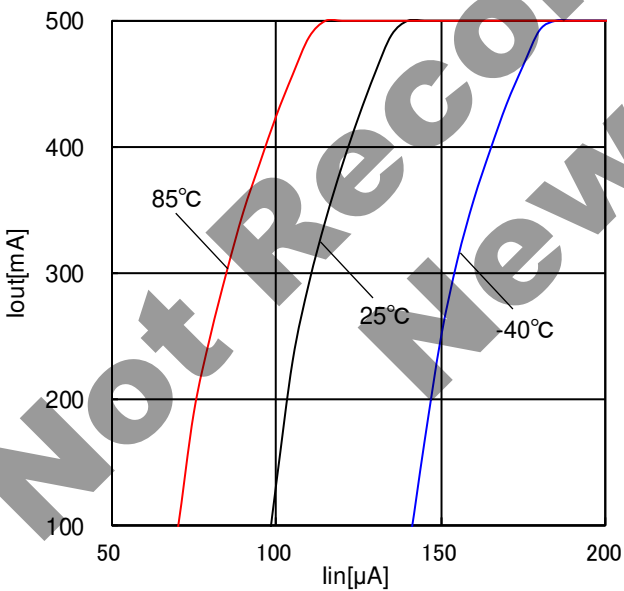

Figure 3 .
Output Current vs Input Current

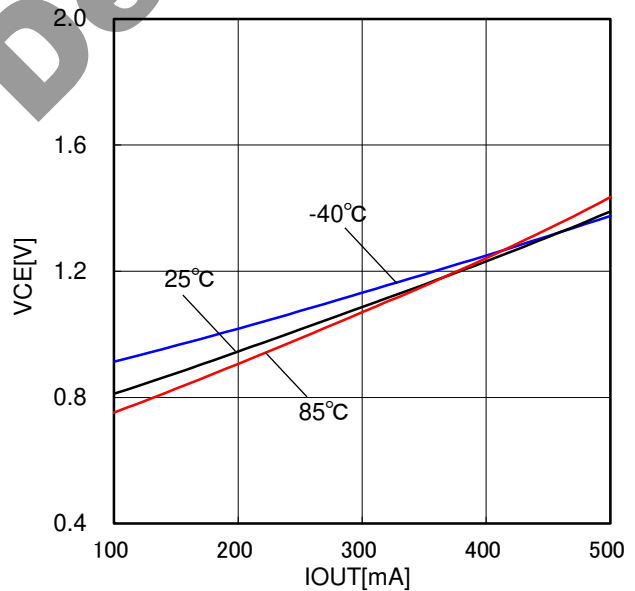

Figure 4 .
Output Saturation Voltage1 vs Output Current

Typical Performance Curve (Reference Data) - continued

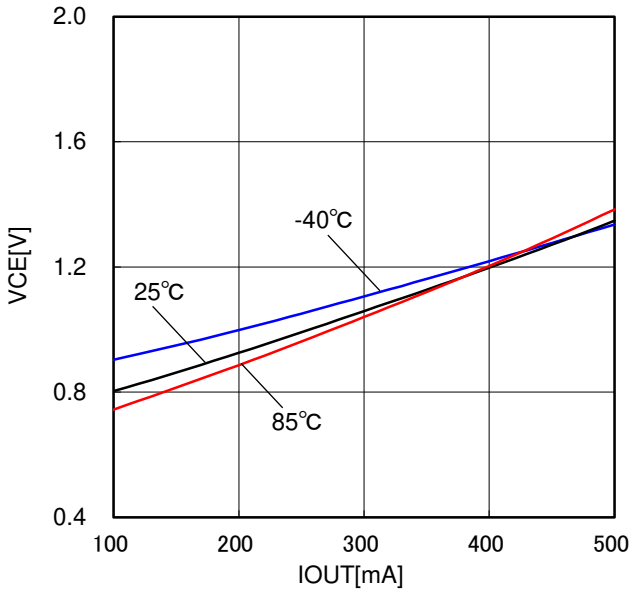

Figure 5 .
Output Saturation Voltage2 vs Output Current

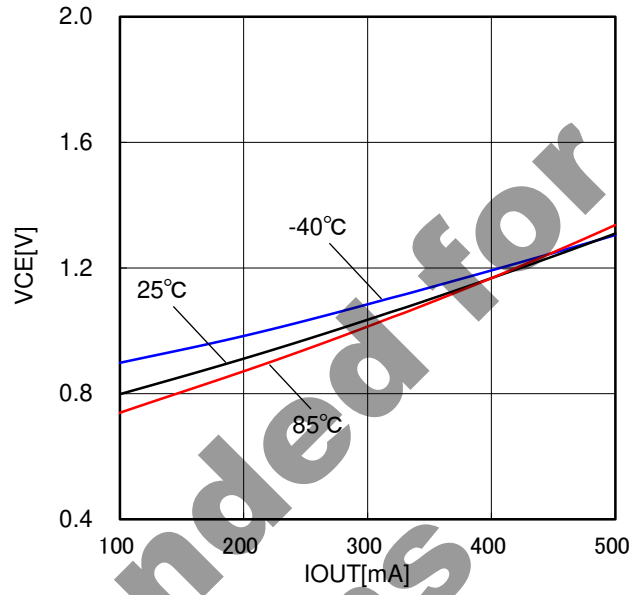

Figure 6 .
Output Saturation Voltage3 vs Output Current

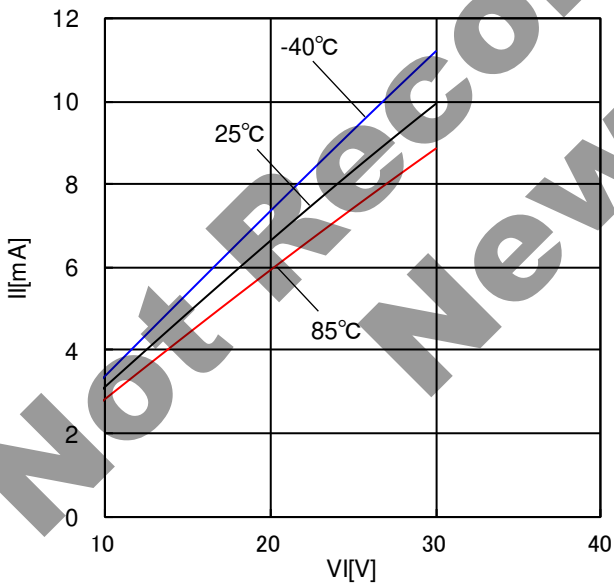

Figure 7 .
Input Current vs Input Voltage
(BA12003)

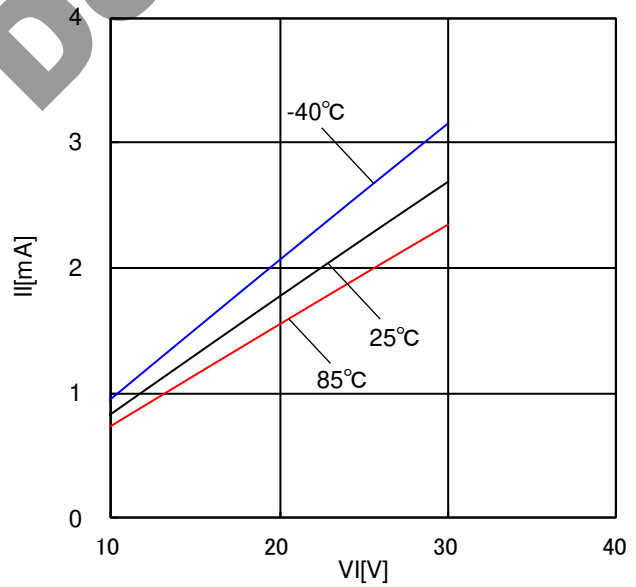

Figure 8 .
Input Current vs Input Voltage
(BA12004)

Typical Performance Curve (Reference Data) - continued

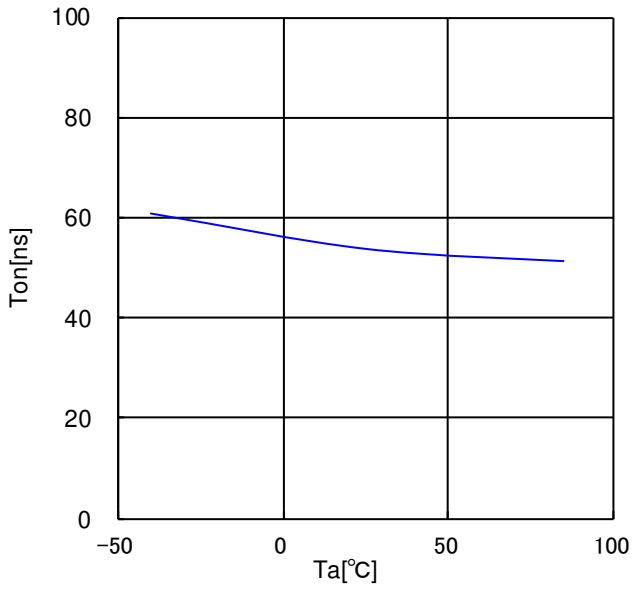

Figure 9 .
Turn-ON Time vs Ambient Temperature

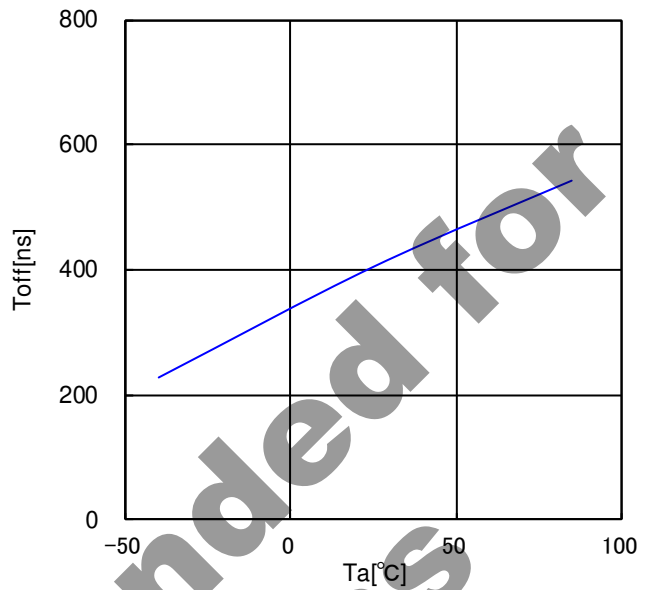

Figure 10 .
Turn-OFF Time vs Ambient Temperature

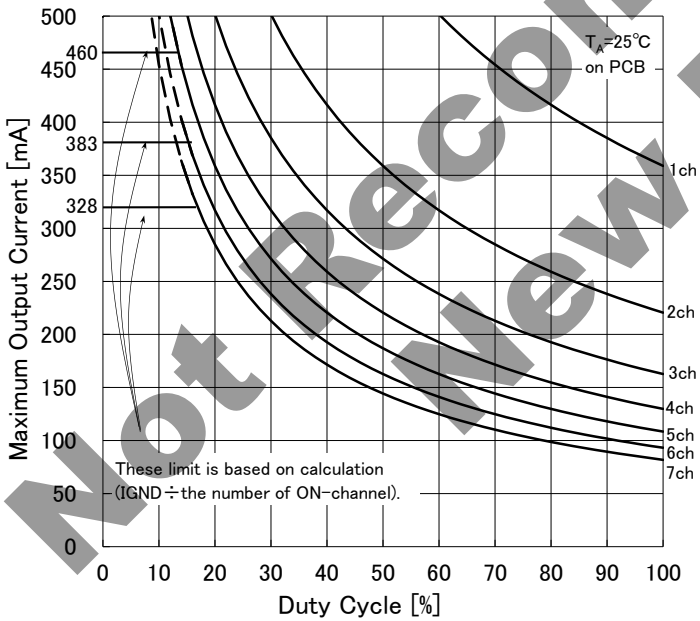

Figure 11.
Output Current - Duty Cycle

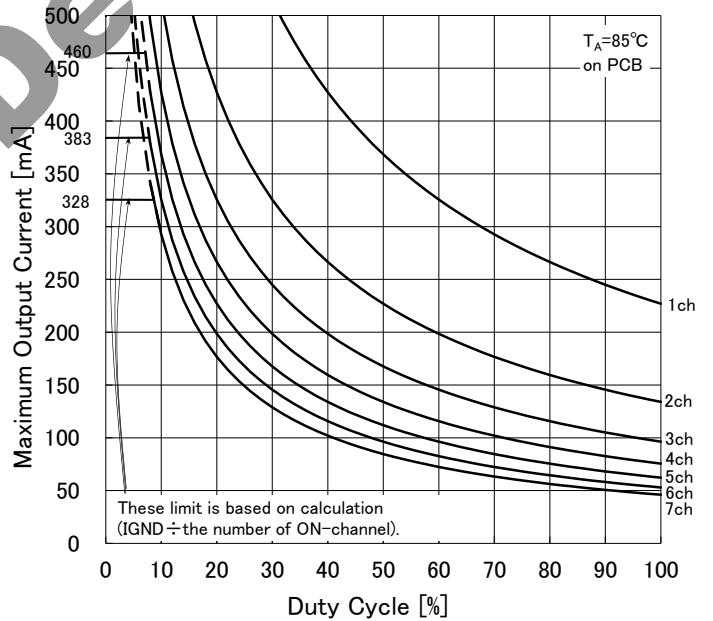

Figure 12.
Output Current - Duty Cycle

Power Dissipation

Power dissipation(total loss) indicates the power that can be consumed by IC at $T_A=25^{\circ}\text{C}$ (normal temperature). IC is heated when it consumed power, and the temperature of IC chip becomes higher than ambient temperature. The temperature that can be accepted by IC chip depends on circuit configuration, manufacturing process, and consumable power is limited. Power dissipation is determined by the temperature allowed in IC chip(maximum junction temperature) and thermal resistance of package(heat dissipation capability). The maximum junction temperature is typically equal to the maximum value in the storage temperature range. Heat generated by consumed power of IC radiates from the mold resin or lead frame of the package. The parameter which indicates this heat dissipation capability(hardness of heat release)is called thermal resistance, represented by the symbol θ_{JA} ($^{\circ}\text{C}/\text{W}$).The temperature of IC inside the package can be estimated by this thermal resistance. Figure 13(a) shows the model of thermal resistance of the package. Thermal resistance θ_{JA} , ambient temperature T_A , maximum junction temperature T_{jmax} , and power dissipation P_d can be calculated by the equation below:

$$\theta_{JA} = (T_{JMAX} - T_A) / P_d \quad [^{\circ}\text{C}/\text{W}]$$

Derating curve in Figure 13(b) indicates power that can be consumed by IC with reference to ambient temperature. Power that can be consumed by IC begins to attenuate at certain ambient temperature. This gradient is determined by thermal resistance θ_{JA} . Thermal resistance θ_{JA} depends on chip size, power consumption, package, ambient temperature, package condition, wind velocity, etc even when the same of package is used. Thermal reduction curve indicates a reference value measured at a specified condition. Figure 14 show a derating curve for an example of BA12003DF-Z, BA12004DF-Z.

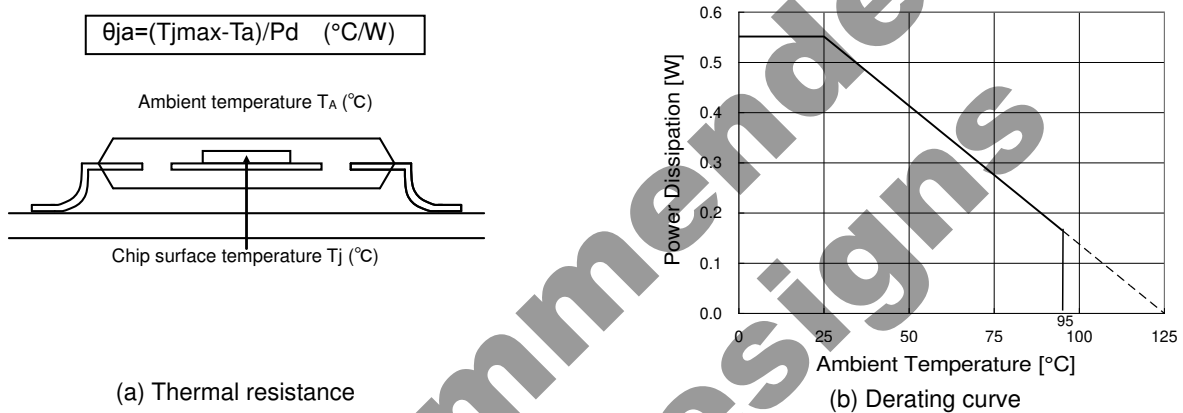

Figure 13. Thermal resistance and derating curve

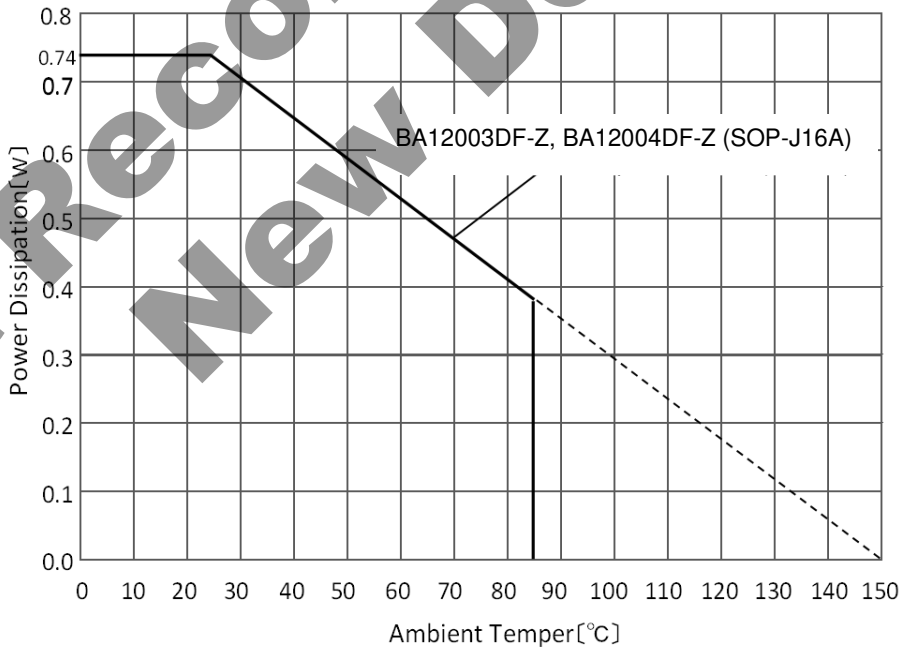

Figure 14. Derating curve

Part Number	Slope of Derating Curve	Unit
BA12003DF-Z, BA12004DF-Z	5.9	mW/ $^{\circ}\text{C}$

Operational Notes

1. Reverse Connection of Power Supply

Connecting the power supply in reverse polarity can damage the IC. Take precautions against reverse polarity when connecting the power supply, such as mounting an external diode between the power supply and the IC's power supply pins.

2. Power Supply Lines

Design the PCB layout pattern to provide low impedance supply lines. Furthermore, connect a capacitor to ground at all power supply pins. Consider the effect of temperature and aging on the capacitance value when using electrolytic capacitors.

3. Ground Voltage

Ensure that no pins are at a voltage below that of the ground pin at any time, even during transient condition. However, pins that drive inductive loads (e.g. motor driver outputs, DC-DC converter outputs) may inevitably go below ground due to back EMF or electromotive force. In such cases, the user should make sure that such voltages going below ground will not cause the IC and the system to malfunction by examining carefully all relevant factors and conditions such as motor characteristics, supply voltage, operating frequency and PCB wiring to name a few.

4. Ground Wiring Pattern

When using both small-signal and large-current ground traces, the two ground traces should be routed separately but connected to a single ground at the reference point of the application board to avoid fluctuations in the small-signal ground caused by large currents. Also ensure that the ground traces of external components do not cause variations on the ground voltage. The ground lines must be as short and thick as possible to reduce line impedance.

5. Thermal Consideration

Should by any chance the maximum junction temperature rating be exceeded the rise in temperature of the chip may result in deterioration of the properties of the chip. In case of exceeding this absolute maximum rating, increase the board size and copper area to prevent exceeding the maximum junction temperature rating.

6. Recommended Operating Conditions

These conditions represent a range within which the expected characteristics of the IC can be approximately obtained. The electrical characteristics are guaranteed under the conditions of each parameter.

7. Inrush Current

When power is first supplied to the IC, it is possible that the internal logic may be unstable and inrush current may flow instantaneously due to the internal powering sequence and delays, especially if the IC has more than one power supply. Therefore, give special consideration to power coupling capacitance, power wiring, width of ground wiring, and routing of connections.

8. Operation Under Strong Electromagnetic Field

Operating the IC in the presence of a strong electromagnetic field may cause the IC to malfunction.

9. Testing on Application Boards

When testing the IC on an application board, connecting a capacitor directly to a low-impedance output pin may subject the IC to stress. Always discharge capacitors completely after each process or step. The IC's power supply should always be turned off completely before connecting or removing it from the test setup during the inspection process. To prevent damage from static discharge, ground the IC during assembly and use similar precautions during transport and storage.

10. Inter-pin Short and Mounting Errors

Ensure that the direction and position are correct when mounting the IC on the PCB. Incorrect mounting may result in damaging the IC. Avoid nearby pins being shorted to each other especially to ground, power supply and output pin. Inter-pin shorts could be due to many reasons such as metal particles, water droplets (in very humid environment) and unintentional solder bridge deposited in between pins during assembly to name a few.

11. Unused Input Pins

Input pins of an IC are often connected to the gate of a MOS transistor. The gate has extremely high impedance and extremely low capacitance. If left unconnected, the electric field from the outside can easily charge it. The small charge acquired in this way is enough to produce a significant effect on the conduction through the transistor and cause unexpected operation of the IC. So unless otherwise specified, unused input pins should be connected to the power supply or ground line.

Operational Notes – continued

12. Regarding the Input Pin of the IC

This monolithic IC contains P+ isolation and P substrate layers between adjacent elements in order to keep them isolated. P-N junctions are formed at the intersection of the P layers with the N layers of other elements, creating a parasitic diode or transistor. For example (refer to figure below):

When GND > Pin A and GND > Pin B, the P-N junction operates as a parasitic diode.
 When GND > Pin B, the P-N junction operates as a parasitic transistor.

Parasitic diodes inevitably occur in the structure of the IC. The operation of parasitic diodes can result in mutual interference among circuits, operational faults, or physical damage. Therefore, conditions that cause these diodes to operate, such as applying a voltage lower than the GND voltage to an input pin (and thus to the P substrate) should be avoided.

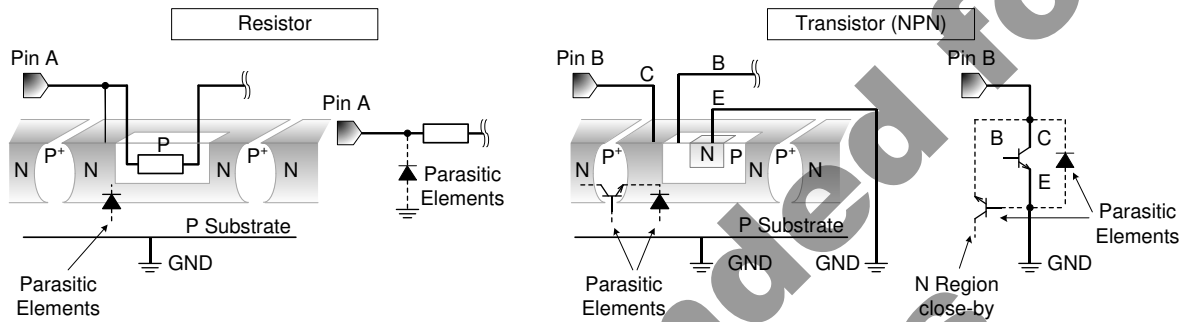

Figure 15. Example of monolithic IC structure

13. Ceramic Capacitor

When using a ceramic capacitor, determine the dielectric constant considering the change of capacitance with temperature and the decrease in nominal capacitance due to DC bias and others.

14. Area of Safe Operation (ASO)

Operate the IC such that the output voltage, output current, and power dissipation are all within the Area of Safe Operation (ASO).

15. Output Pins

Connecting zener diode should be able to prevent degradation of current time. Please use zener diode satisfy with $V_{CC} + V_Z \leq V_{CE(SUS)}$.

16. Output clamp diode

Figure 16 is a construction of the clamp diode part in this IC. When the clamp diode works, PNP transistor works. Therefore, a consumption power increases. When a consecutive surge current (or backward current of motor) flows in this clamp diode, we recommend the diode with a low forward voltage etc. (schottky diode) connection between OUT and COM for bypass pathway of surge current.

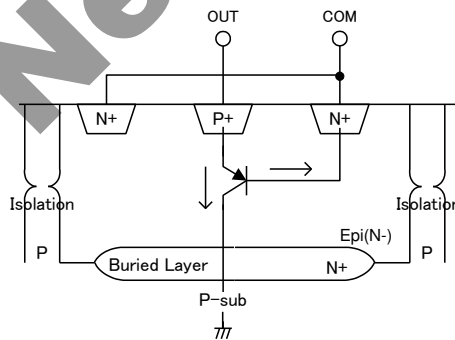
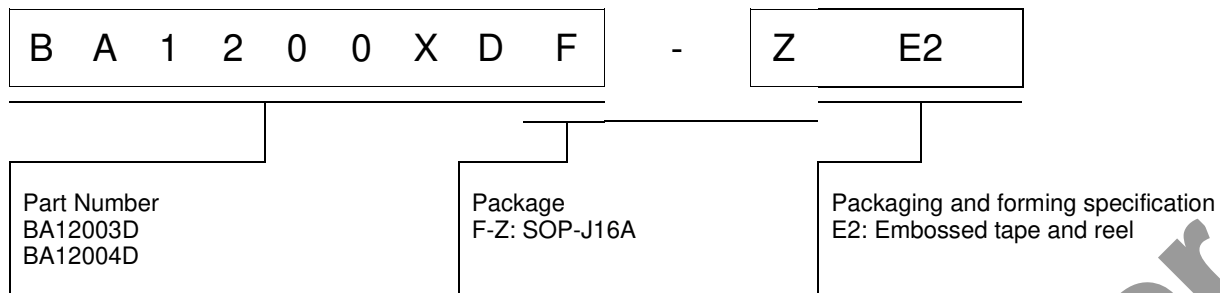

Figure 16. Construction of output clamp diode

Ordering Information



Marking Diagrams

SOP-J16A (TOP VIEW)

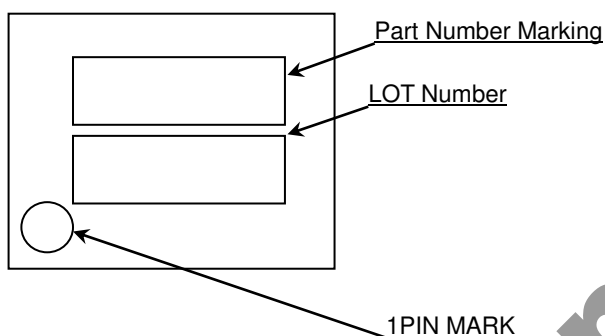

Lineup

Part Number Marking	Package	Orderable Part Number
A12003DF	SOP-J16A	BA12003DF-ZE2
A12004DF	SOP-J16A	BA12004DF-ZE2

Physical Dimension, Tape and Reel Information

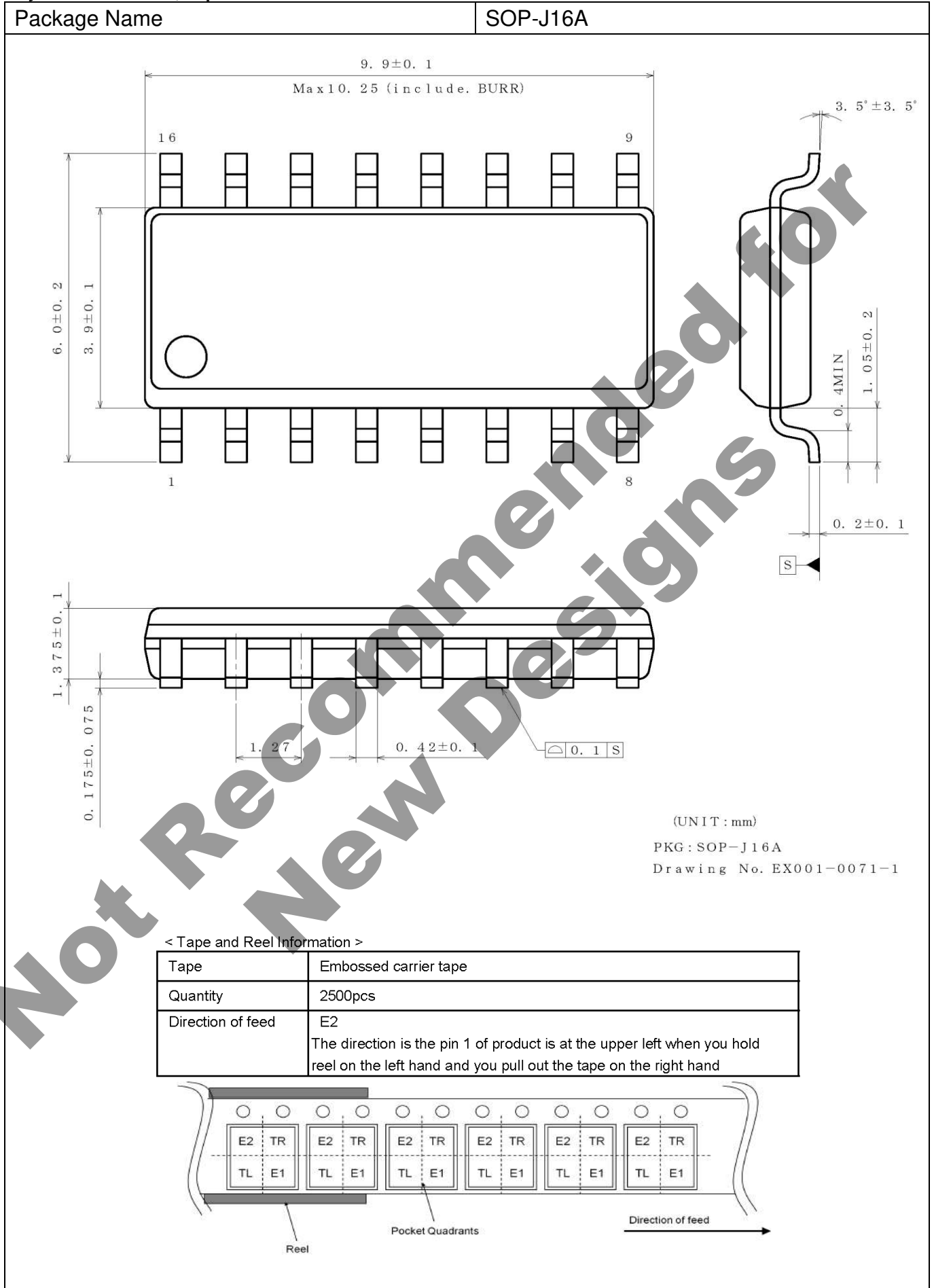

Revision History

Date	Revision	Changes
13.Jun.2016	001	New Release
6.Jul.2016	002	Update Lineup
29.Nov.2016	003	Update Physical Dimension and Package Name
20.Dec.2016	004	Update Lineup
10.Feb.2017	005	Update Lineup
02.Jun.2017	006	Update Lineup
09.Aug.2017	007	Update Marking Diagrams and Lineup
26.Sep.2017	008	Update Lineup
24.Aug.2018	009	Update Lineup
27.Aug.2020	010	Physical Dimension, Tape and Reel Information (P.12) Change dimension to JEDEC standard values.

Not Recommended for
New Designs

Notice

Precaution on using ROHM Products

- Our Products are designed and manufactured for application in ordinary electronic equipment (such as AV equipment, OA equipment, telecommunication equipment, home electronic appliances, amusement equipment, etc.). If you intend to use our Products in devices requiring extremely high reliability (such as medical equipment ^(Note 1), transport equipment, traffic equipment, aircraft/spacecraft, nuclear power controllers, fuel controllers, car equipment including car accessories, safety devices, etc.) and whose malfunction or failure may cause loss of human life, bodily injury or serious damage to property ("Specific Applications"), please consult with the ROHM sales representative in advance. Unless otherwise agreed in writing by ROHM in advance, ROHM shall not be in any way responsible or liable for any damages, expenses or losses incurred by you or third parties arising from the use of any ROHM's Products for Specific Applications.

(Note1) Medical Equipment Classification of the Specific Applications

JAPAN	USA	EU	CHINA
CLASS III	CLASS III	CLASS II b	CLASS III
CLASS IV		CLASS III	

- ROHM designs and manufactures its Products subject to strict quality control system. However, semiconductor products can fail or malfunction at a certain rate. Please be sure to implement, at your own responsibilities, adequate safety measures including but not limited to fail-safe design against the physical injury, damage to any property, which a failure or malfunction of our Products may cause. The following are examples of safety measures:
 - Installation of protection circuits or other protective devices to improve system safety
 - Installation of redundant circuits to reduce the impact of single or multiple circuit failure
- Our Products are designed and manufactured for use under standard conditions and not under any special or extraordinary environments or conditions, as exemplified below. Accordingly, ROHM shall not be in any way responsible or liable for any damages, expenses or losses arising from the use of any ROHM's Products under any special or extraordinary environments or conditions. If you intend to use our Products under any special or extraordinary environments or conditions (as exemplified below), your independent verification and confirmation of product performance, reliability, etc. prior to use, must be necessary:
 - Use of our Products in any types of liquid, including water, oils, chemicals, and organic solvents
 - Use of our Products outdoors or in places where the Products are exposed to direct sunlight or dust
 - Use of our Products in places where the Products are exposed to sea wind or corrosive gases, including Cl₂, H₂S, NH₃, SO₂, and NO₂
 - Use of our Products in places where the Products are exposed to static electricity or electromagnetic waves
 - Use of our Products in proximity to heat-producing components, plastic cords, or other flammable items
 - Sealing or coating our Products with resin or other coating materials
 - Use of our Products without cleaning residue of flux (Exclude cases where no-clean type fluxes is used. However, recommend sufficiently about the residue.) ; or Washing our Products by using water or water-soluble cleaning agents for cleaning residue after soldering
 - Use of the Products in places subject to dew condensation
- The Products are not subject to radiation-proof design.
- Please verify and confirm characteristics of the final or mounted products in using the Products.
- In particular, if a transient load (a large amount of load applied in a short period of time, such as pulse, is applied, confirmation of performance characteristics after on-board mounting is strongly recommended. Avoid applying power exceeding normal rated power; exceeding the power rating under steady-state loading condition may negatively affect product performance and reliability.
- De-rate Power Dissipation depending on ambient temperature. When used in sealed area, confirm that it is the use in the range that does not exceed the maximum junction temperature.
- Confirm that operation temperature is within the specified range described in the product specification.
- ROHM shall not be in any way responsible or liable for failure induced under deviant condition from what is defined in this document.

Precaution for Mounting / Circuit board design

- When a highly active halogenous (chlorine, bromine, etc.) flux is used, the residue of flux may negatively affect product performance and reliability.
- In principle, the reflow soldering method must be used on a surface-mount products, the flow soldering method must be used on a through hole mount products. If the flow soldering method is preferred on a surface-mount products, please consult with the ROHM representative in advance.

For details, please refer to ROHM Mounting specification

Precautions Regarding Application Examples and External Circuits

1. If change is made to the constant of an external circuit, please allow a sufficient margin considering variations of the characteristics of the Products and external components, including transient characteristics, as well as static characteristics.
2. You agree that application notes, reference designs, and associated data and information contained in this document are presented only as guidance for Products use. Therefore, in case you use such information, you are solely responsible for it and you must exercise your own independent verification and judgment in the use of such information contained in this document. ROHM shall not be in any way responsible or liable for any damages, expenses or losses incurred by you or third parties arising from the use of such information.

Precaution for Electrostatic

This Product is electrostatic sensitive product, which may be damaged due to electrostatic discharge. Please take proper caution in your manufacturing process and storage so that voltage exceeding the Products maximum rating will not be applied to Products. Please take special care under dry condition (e.g. Grounding of human body / equipment / solder iron, isolation from charged objects, setting of ionizer, friction prevention and temperature / humidity control).

Precaution for Storage / Transportation

1. Product performance and soldered connections may deteriorate if the Products are stored in the places where:
 - [a] the Products are exposed to sea winds or corrosive gases, including Cl₂, H₂S, NH₃, SO₂, and NO₂
 - [b] the temperature or humidity exceeds those recommended by ROHM
 - [c] the Products are exposed to direct sunshine or condensation
 - [d] the Products are exposed to high Electrostatic
2. Even under ROHM recommended storage condition, solderability of products out of recommended storage time period may be degraded. It is strongly recommended to confirm solderability before using Products of which storage time is exceeding the recommended storage time period.
3. Store / transport cartons in the correct direction, which is indicated on a carton with a symbol. Otherwise bent leads may occur due to excessive stress applied when dropping of a carton.
4. Use Products within the specified time after opening a humidity barrier bag. Baking is required before using Products of which storage time is exceeding the recommended storage time period.

Precaution for Product Label

A two-dimensional barcode printed on ROHM Products label is for ROHM's internal use only.

Precaution for Disposition

When disposing Products please dispose them properly using an authorized industry waste company.

Precaution for Foreign Exchange and Foreign Trade act

Since concerned goods might be fallen under listed items of export control prescribed by Foreign exchange and Foreign trade act, please consult with ROHM in case of export.

Precaution Regarding Intellectual Property Rights

1. All information and data including but not limited to application example contained in this document is for reference only. ROHM does not warrant that foregoing information or data will not infringe any intellectual property rights or any other rights of any third party regarding such information or data.
2. ROHM shall not have any obligations where the claims, actions or demands arising from the combination of the Products with other articles such as components, circuits, systems or external equipment (including software).
3. No license, expressly or implied, is granted hereby under any intellectual property rights or other rights of ROHM or any third parties with respect to the Products or the information contained in this document. Provided, however, that ROHM will not assert its intellectual property rights or other rights against you or your customers to the extent necessary to manufacture or sell products containing the Products, subject to the terms and conditions herein.

Other Precaution

1. This document may not be reprinted or reproduced, in whole or in part, without prior written consent of ROHM.
2. The Products may not be disassembled, converted, modified, reproduced or otherwise changed without prior written consent of ROHM.
3. In no event shall you use in any way whatsoever the Products and the related technical information contained in the Products or this document for any military purposes, including but not limited to, the development of mass-destruction weapons.
4. The proper names of companies or products described in this document are trademarks or registered trademarks of ROHM, its affiliated companies or third parties.

General Precaution

1. Before you use our Products, you are requested to carefully read this document and fully understand its contents. ROHM shall not be in any way responsible or liable for failure, malfunction or accident arising from the use of any ROHM's Products against warning, caution or note contained in this document.
2. All information contained in this document is current as of the issuing date and subject to change without any prior notice. Before purchasing or using ROHM's Products, please confirm the latest information with a ROHM sales representative.
3. The information contained in this document is provided on an "as is" basis and ROHM does not warrant that all information contained in this document is accurate and/or error-free. ROHM shall not be in any way responsible or liable for any damages, expenses or losses incurred by you or third parties resulting from inaccuracy or errors of or concerning such information.

**Not Recommended for
New Designs**