

## 8A, 50V - 600V Super Fast Surface Mount Rectifier

### FEATURES

- Glass passivated chip junction
- Ideal for automated placement
- High efficiency, low  $V_F$
- High surge current capability
- Low power loss
- Moisture sensitivity level: level 1, per J-STD-020
- RoHS Compliant
- Halogen-free according to IEC 61249-2-21

### APPLICATIONS

- DC to DC converter
- Switching mode converters and inverters
- Freewheeling application

### MECHANICAL DATA

- Case: TO-263AB (D<sup>2</sup>PAK)
- Molding compound meets UL 94V-0 flammability rating
- Terminal: Matte tin plated leads, solderable per J-STD-002
- Meet JESD 201 class 2 whisker test
- Polarity: As marked
- Weight: 1.33g (approximately)

KEY PARAMETERS		
PARAMETER	VALUE	UNIT
$I_F$	8	A
$V_{RRM}$	50 - 600	V
$I_{FSM}$	125	A
$T_{JMAX}$	150	°C
Package	TO-263AB (D <sup>2</sup> PAK)	
Configuration	Single die	

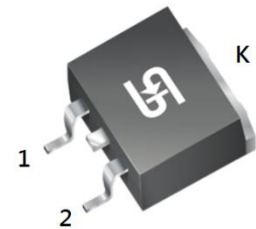
**TO-263AB (D<sup>2</sup>PAK)**

ABSOLUTE MAXIMUM RATINGS ( $T_A = 25^\circ\text{C}$ unless otherwise noted)										
PARAMETER	SYMBOL	SFAS 801G	SFAS 802G	SFAS 803G	SFAS 804G	SFAS 805G	SFAS 806G	SFAS 807G	SFAS 808G	UNIT
Marking code on the device		SFAS 801G	SFAS 802G	SFAS 803G	SFAS 804G	SFAS 805G	SFAS 806G	SFAS 807G	SFAS 808G	
Repetitive peak reverse voltage	$V_{RRM}$	50	100	150	200	300	400	500	600	V
Reverse voltage, total rms value	$V_{R(RMS)}$	35	70	105	140	210	280	350	420	V
Forward current	$I_F$	8								A
Surge peak forward current, 8.3ms single half sine wave superimposed on rated load	$I_{FSM}$	125								A
Junction temperature	$T_J$	-55 to +150								°C
Storage temperature	$T_{STG}$	-55 to +150								°C

<b>THERMAL PERFORMANCE</b>			
<b>PARAMETER</b>	<b>SYMBOL</b>	<b>TYP</b>	<b>UNIT</b>
Junction-to-case thermal resistance	$R_{\theta JC}$	2.2	°C/W

<b>ELECTRICAL SPECIFICATIONS</b> ( $T_A = 25^\circ\text{C}$ unless otherwise noted)								
<b>PARAMETER</b>		<b>CONDITIONS</b>	<b>SYMBOL</b>	<b>TYP</b>	<b>MAX</b>	<b>UNIT</b>		
Forward voltage <sup>(1)</sup>	SFAS801G	$I_F = 8\text{A}, T_J = 25^\circ\text{C}$	$V_F$	-	0.95	V		
	SFAS802G				-	1.30	V	
	SFAS803G					-	1.70	V
	SFAS804G			-				
	SFAS805G				-			
	SFAS806G					-		
SFAS807G	-							
SFAS808G		-						
Reverse current @ rated $V_R$ <sup>(2)</sup>			$T_J = 25^\circ\text{C}$	$I_R$	-	10	$\mu\text{A}$	
			$T_J = 100^\circ\text{C}$		-	400	$\mu\text{A}$	
Junction capacitance	SFAS801G	1MHz, $V_R = 4.0\text{V}$	$C_J$	80	-	$\text{pF}$		
	SFAS802G						-	$\text{pF}$
	SFAS803G							
	SFAS804G			-	$\text{pF}$			
	SFAS805G					-	$\text{pF}$	
	SFAS806G							-
SFAS807G	-	$\text{pF}$						
SFAS808G			-	$\text{pF}$				
Reverse recovery time					$I_F = 0.5\text{A}, I_R = 1.0\text{A}$ $I_{rr} = 0.25\text{A}$	$t_{rr}$	-	35

**Notes:**

1. Pulse test with  $PW = 0.3\text{ms}$
2. Pulse test with  $PW = 30\text{ms}$

<b>ORDERING INFORMATION</b>		
<b>ORDERING CODE<sup>(1)</sup></b>	<b>PACKAGE</b>	<b>PACKING</b>
SFAS8xG	TO-263AB (D <sup>2</sup> PAK)	800 / Tape & Reel

**Notes:**

1. "x" defines voltage from 50V(SFAS801G) to 600V(SFAS808G)

**CHARACTERISTICS CURVES**

( $T_A = 25^\circ\text{C}$  unless otherwise noted)

**Fig.1 Forward Current Derating Curve**

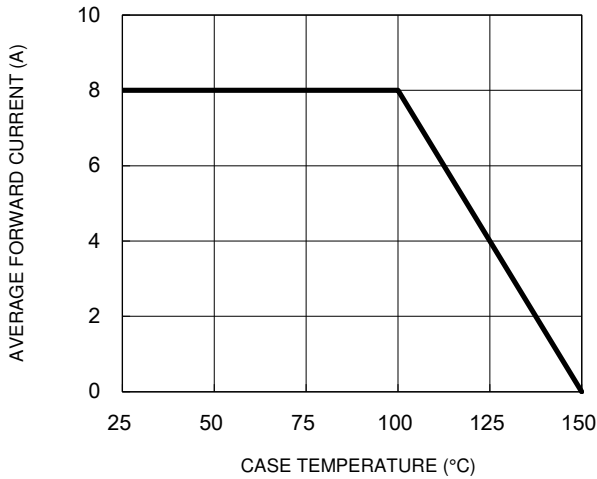

**Fig.2 Typical Junction Capacitance**

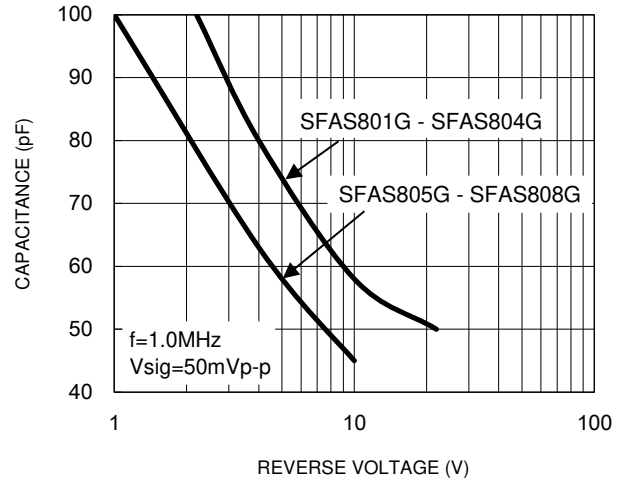

**Fig.3 Typical Reverse Characteristics**

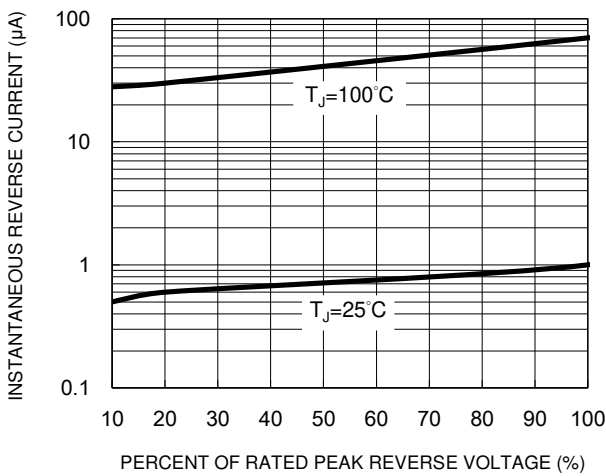

**Fig.4 Typical Forward Characteristics**

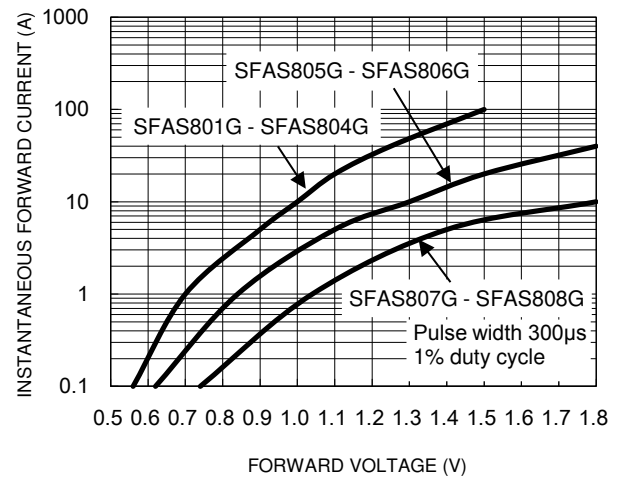

**Fig.5 Maximum Non-Repetitive Forward Surge Current**

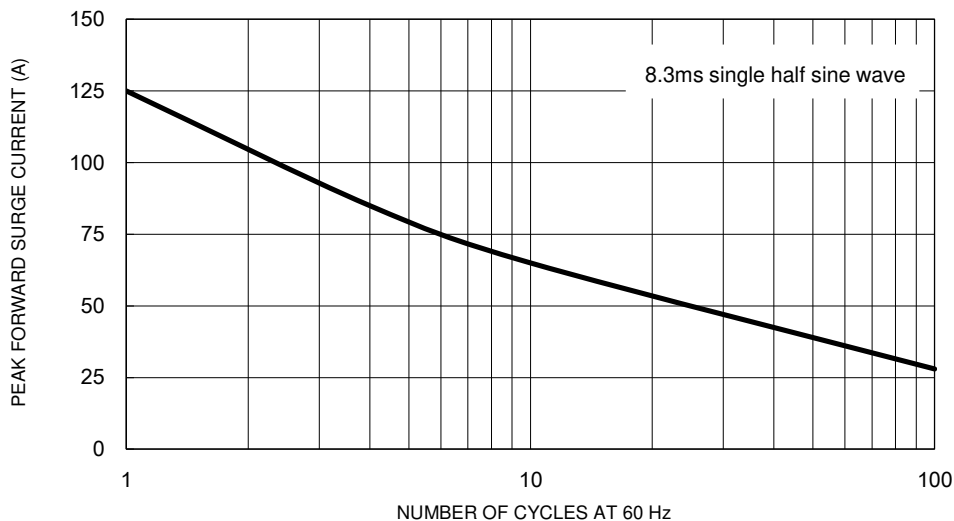

**CHARACTERISTICS CURVES**

( $T_A = 25^\circ\text{C}$  unless otherwise noted)

**Fig.6 Reverse Recovery Time Characteristic and Test Circuit Diagram**

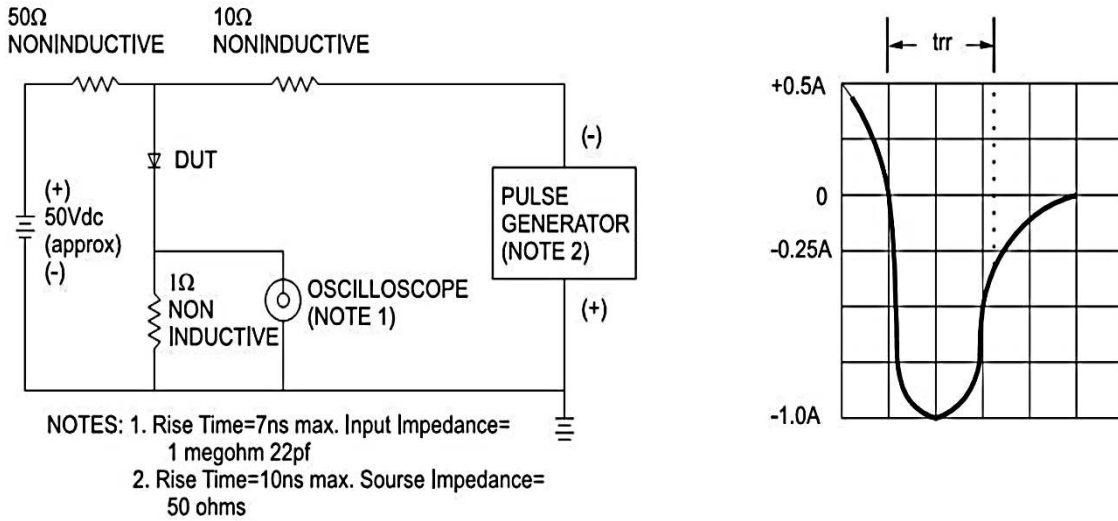

**PACKAGE OUTLINE DIMENSIONS**

TO-263AB (D<sup>2</sup>PAK)

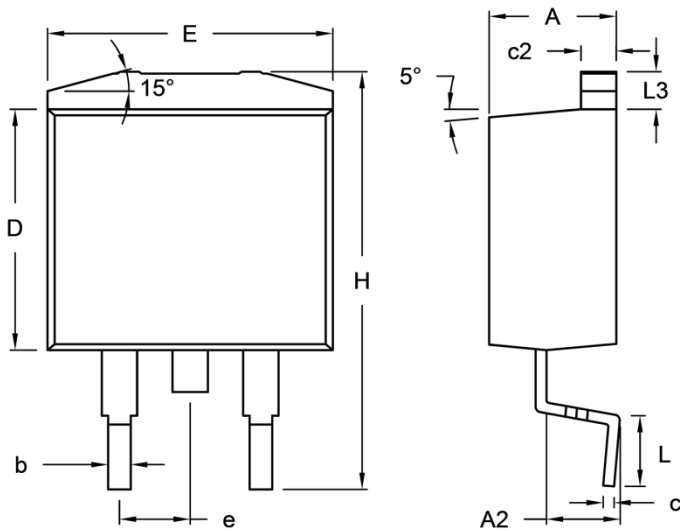

DIM.	Unit (mm)		Unit (inch)	
	Min.	Max.	Min.	Max.
A	4.44	4.70	0.175	0.185
A2	2.03	2.79	0.080	0.110
b	0.68	0.94	0.027	0.037
c	0.36	0.53	0.014	0.021
c2	1.14	1.40	0.045	0.055
D	8.25	9.25	0.325	0.364
E	-	10.50	-	0.413
e	2.41	2.67	0.095	0.105
H	14.60	15.88	0.575	0.625
L	2.29	2.79	0.090	0.110
L3	1.14	1.40	0.045	0.055

**SUGGESTED PAD LAYOUT**

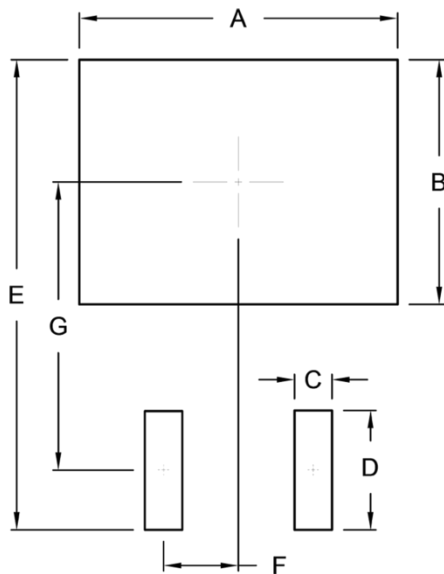

Symbol	Unit (mm)	Unit (inch)
A	10.80	0.425
B	8.30	0.327
C	1.27	0.050
D	4.05	0.159
E	15.95	0.628
F	2.54	0.100
G	9.775	0.385

**MARKING DIAGRAM**



- P/N = Marking Code
- G = Green Compound
- YWW = Date Code
- F = Factory Code

## **Notice**

Specifications of the products displayed herein are subject to change without notice. TSC or anyone on its behalf assumes no responsibility or liability for any errors or inaccuracies.

Purchasers are solely responsible for the choice, selection, and use of TSC products and TSC assumes no liability for application assistance or the design of Purchasers' products.

Information contained herein is intended to provide a product description only. No license, express or implied, to any intellectual property rights is granted by this document. Except as provided in TSC's terms and conditions of sale for such products, TSC assumes no liability whatsoever, and disclaims any express or implied warranty, relating to sale and/or use of TSC products including liability or warranties relating to fitness for a particular purpose, merchantability, or infringement of any patent, copyright, or other intellectual property right.

The products shown herein are not designed for use in medical, life-saving, or life-sustaining applications. Customers using or selling these products for use in such applications do so at their own risk and agree to fully indemnify TSC for any damages resulting from such improper use or sale.