

DETAIL B
SCALE 20:1

- 1 FINISH: 0.00076 MIN GOLD PER 112-162-5 ON TOP AND BOTTOM ONLY IN LOCALIZED GOLD PLATE AREA AS SPECIFIED, GOLD FLASH PER 112-33-1 FOR A LENGTH OF 2.54 ON ALL SURFACES. 0.00381-0.00635 MATTE TIN LEAD PER 112-26-2 ON AREA AS INDICATED, UNDERPLATING TO BE 0.00127-0.00254 NICKEL PER 112-25-2 ON ENTIRE CONTACT, GOLD AND TIN MAY NOT OVERLAP
- 2 FINISH: 0.00003 MIN. GOLD PER 112-162-5 ON GOLD PLATED AREA, 0.00381-0.00635 MATTE TIN LEAD PER 112-26-2 ON TIN PLATE AREA, UNDERPLATING TO BE 0.00127-0.00254 NICKEL PER 112-25-2 ON ENTIRE CONTACT, GOLD AND TIN MAY NOT OVERLAP
- 3 FINISH: 0.00076 MIN. GOLD PER 112-162-5 ON TOP AND BOTTOM ONLY IN LOCALIZED GOLD PLATE AREA AS SPECIFIED, GOLD FLASH PER 112-33-1 FOR A LENGTH OF 2.54 ON ALL SURFACES. 0.00381-0.00635 MATTE TIN PER 112-65-1 ON AREA AS INDICATED, UNDERPLATING TO BE 0.00127-0.00254 NICKEL PER 112-25-2 ON ENTIRE CONTACT, GOLD AND TIN MAY NOT OVERLAP
- 4 FINISH: 0.00003 MIN. GOLD PER 112-162-5 ON GOLD PLATED AREA, 0.00381-0.00635 MATTE TIN PER 112-65-1 ON TIN PLATE AREA, UNDERPLATING TO BE 0.00127-0.00254 NICKEL PER 112-25-2 ON ENTIRE CONTACT, GOLD AND TIN MAY NOT OVERLAP

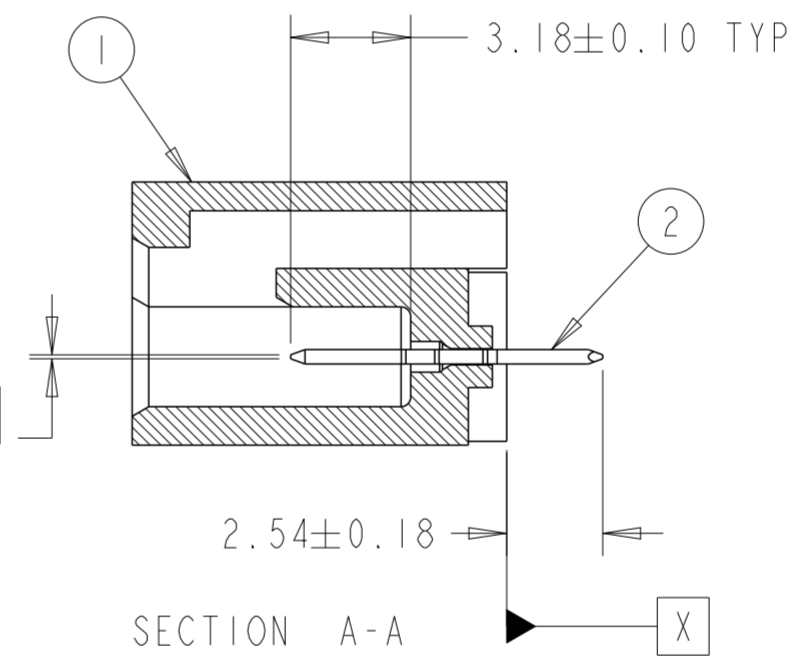
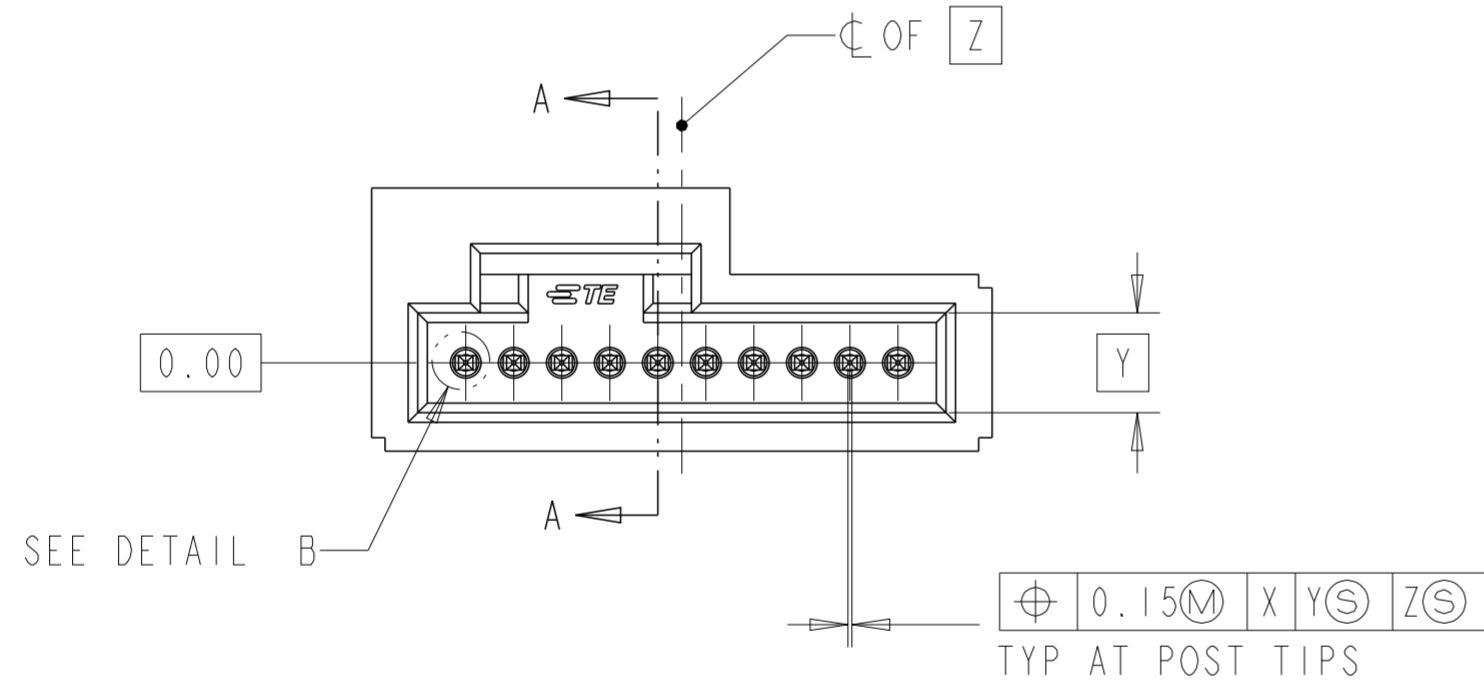

BASIC DIMENSIONS FOR
ODD NO OF SPACES
(SEE TABLE)

SCALE 10:1

BASIC DIMENSIONS FOR
EVEN NO OF SPACES
(SEE TABLE)

SCALE 10:1

4	10	5-2267070-2	1	146086-1	9	10	7-146087-2
3	10	5-103917-2	1	146086-1	9	10	5-146087-1
2	10	2267070-2	1	146086-1	9	10	2-146087-1
1	10	103917-2	1	146086-1	9	10	146087-1
FINISH	QTY	CONTACT PART NO. (2)	QTY	HOUSING PART NO. (1)	NO. OF SPACES	NO. OF POSN	PART NO.

G	REV/REDRAWN PER ECO-17-001745	04DEC2017	MM	JO	
F	REVISED PER ECO-15-004125	22JUN2015	NK	JO	
P	LTR	REVISION RECORD	DATE	DWN	APVD

DIMENSIONS:		TOLERANCES UNLESS OTHERWISE SPECIFIED:	
mm		0 PLC	±
		1 PLC	±0.3
		2 PLC	±0.13
		3 PLC	±
		4 PLC	±
ANGLES: 0.5°		SURFACE TEXTURE	

DWN	16NOV2016	MATERIAL		HEAT TREAT	
CHK	17NOV2016	TE Connectivity			
APVD	18NOV2016				
NAME	J. OLSON				
HEADER ASSEMBLY, VERTICAL, SINGLE ROW, W/ SHROUDED SIDE LATCH, AMPMODU SYSTEM 50					
SCALE	5:1	SIZE	A2	DRAWING NO	146087
				SHEET	1 OF 1
				REV	G