

# Ceramic Chip Antennas

For 2.4GHz ISM band

## ANT Series

Type:            **ANT020012CCS2442MA1 (2.0×1.25×0.5mm)**  
                     **ANT030012CCS2442MA1 (3.0×1.2×1.2mm)**  
                     **ANT040015CCS2442MA1 (4.0×1.5×1.85mm)**  
                     **ANT098030CGS2442MA1 (9.8×3.0×4.0mm)**  
                     **ANT098030CGS2442MB1 (9.8×3.0×4.0mm)**

Issue date:     March 2011

- All specifications are subject to change without notice.
  - Conformity to RoHS Directive: This means that, in conformity with EU Directive 2002/95/EC, lead, cadmium, mercury, hexavalent chromium, and specific bromine-based flame retardants, PBB and PBDE, have not been used, except for exempted applications.
-

# Ceramic Chip Antennas For 2.4GHz ISM band

Conformity to RoHS Directive

ANT Series ANT020012CCS2442MA1

## SHAPES AND DIMENSIONS

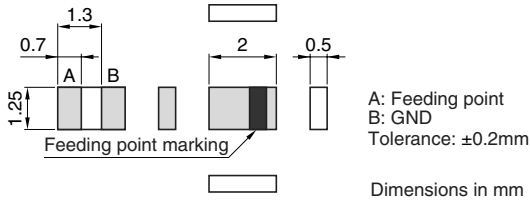

## RECOMMENDED PC BOARD PATTERNS ELECTRODE

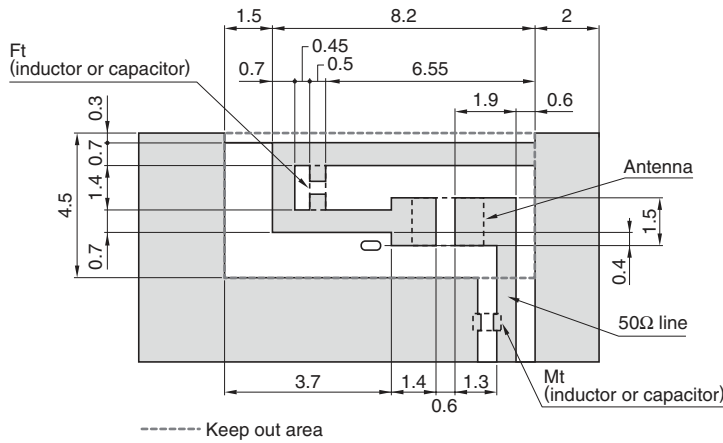

## SOLDER RESIST

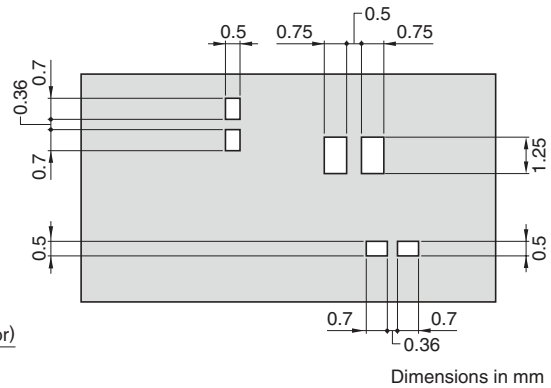

## ELECTRICAL CHARACTERISTICS

|                           |                        |
|---------------------------|------------------------|
| Center frequency( $F_0$ ) | 2442MHz                |
| Band width(BW)            | $F_0 \pm 42$ MHz       |
| Return loss(at BW)        | -5max.                 |
| Polarization              | Linear                 |
| Impedance                 | 50Ω                    |
| PCB size                  | 100×40×1.0mm           |
| Temperature range         | Operating -40 to +85°C |
|                           | Storage -40 to +85°C   |

• This is typical antenna performance with the standard PCB.

## FREQUENCY CHARACTERISTICS EFFICIENCY AND RETURN LOSS

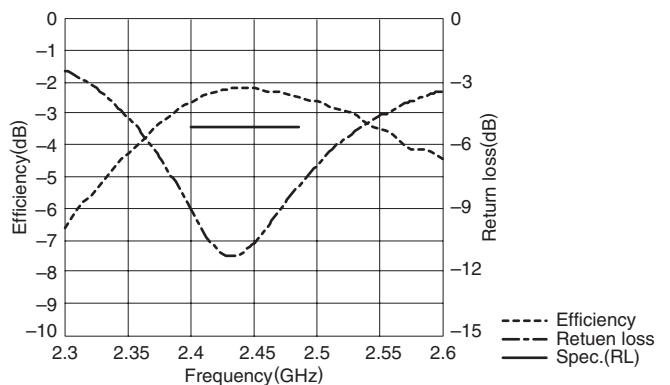

• Conformity to RoHS Directive: This means that, in conformity with EU Directive 2002/95/EC, lead, cadmium, mercury, hexavalent chromium, and specific bromine-based flame retardants, PBB and PBDE, have not been used, except for exempted applications.

• All specifications are subject to change without notice.

### RADIATION PATTERNS ANT020012CCS2442MA1

Directivity angle

Vertical polarization



Horizontal polarization

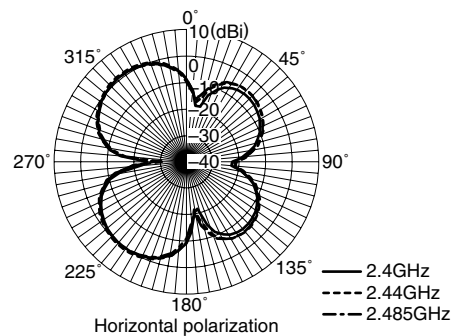
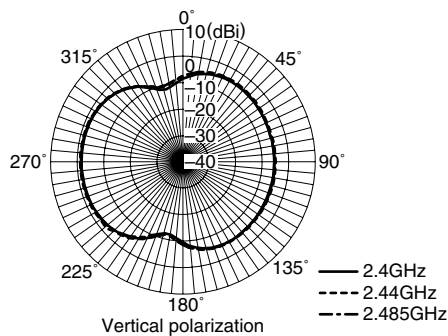
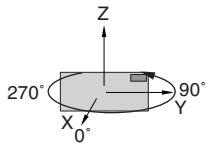
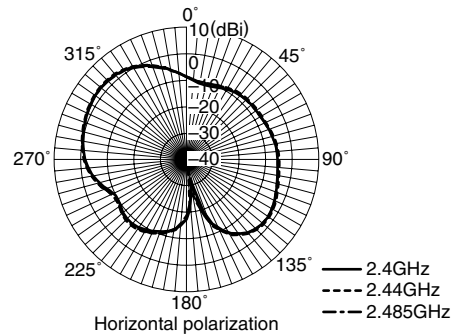
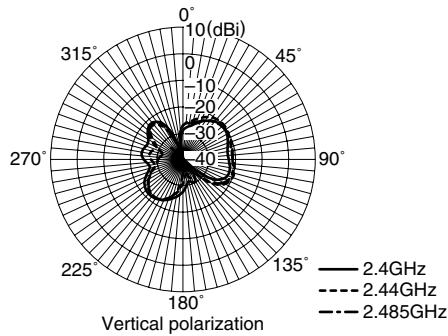
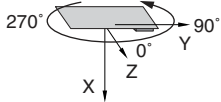
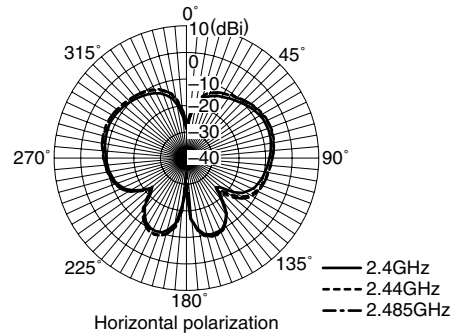
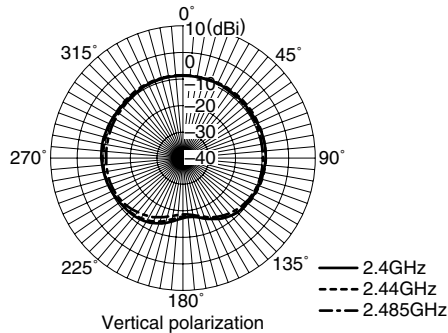
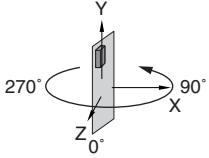
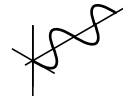

• Tested antenna has been soldered.

• All specifications are subject to change without notice.

# Ceramic Chip Antennas For 2.4GHz ISM band

Conformity to RoHS Directive

ANT Series ANT030012CCS2442MA1

## SHAPES AND DIMENSIONS

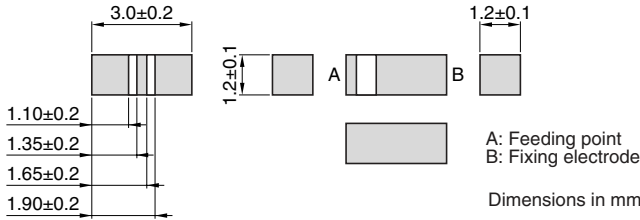

## RECOMMENDED PC BOARD PATTERNS ELECTRODE

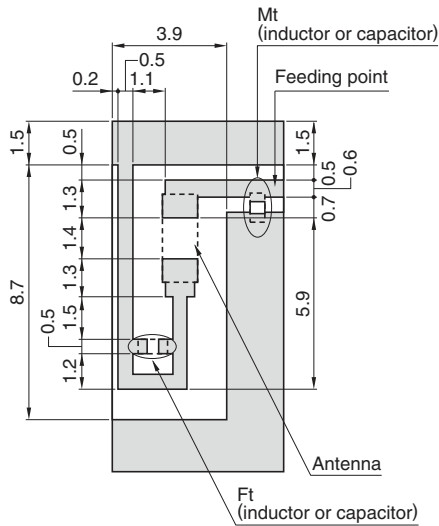

## SOLDER RESIST

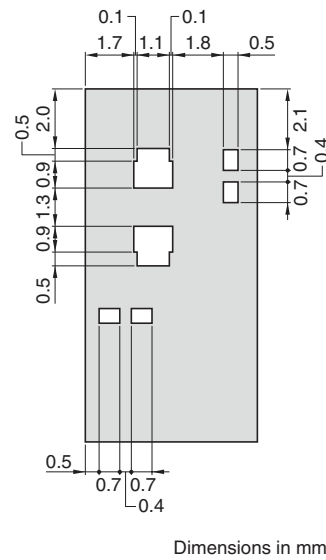

## ELECTRICAL CHARACTERISTICS

|                           |  |
|---------------------------|--|
| Center frequency( $F_0$ ) | 2618MHz  |
| Band width(BW)            | $F_0 \pm 42$ MHz                               |
| VSWR(at BW)               | 3.7max.  |
| Polarization              | Linear   |
| Impedance                 | 50 $\Omega$                                    |
| PCB size                  | 80×37×1.0mm                                    |
| Temperature range         | Operating -40 to +85°C<br>Storage -40 to +85°C |

• This is typical antenna performance with the standard PCB.

## FREQUENCY CHARACTERISTICS EFFICIENCY AND VSWR

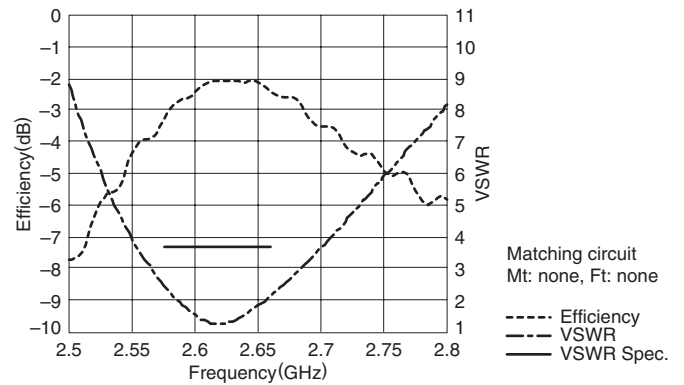

• Conformity to RoHS Directive: This means that, in conformity with EU Directive 2002/95/EC, lead, cadmium, mercury, hexavalent chromium, and specific bromine-based flame retardants, PBB and PBDE, have not been used, except for exempted applications.

• All specifications are subject to change without notice.

**RADIATION PATTERNS**  
**ANT030012CCS2442MA1**

Directivity angle

Vertical polarization



Horizontal polarization

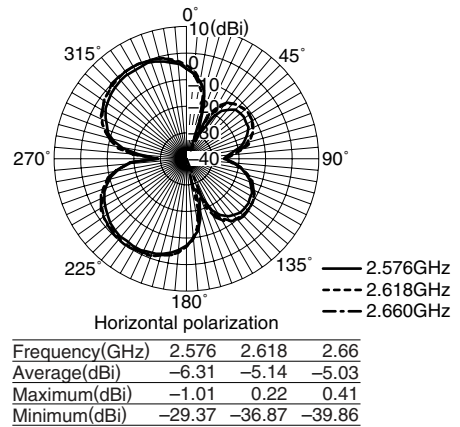
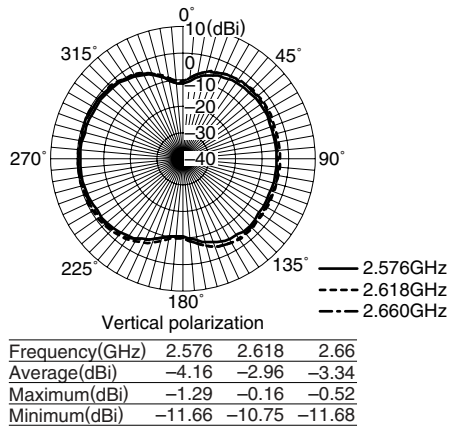
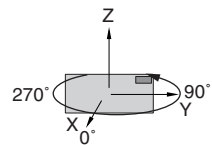
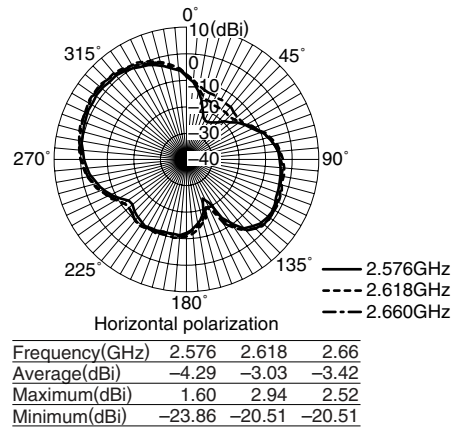
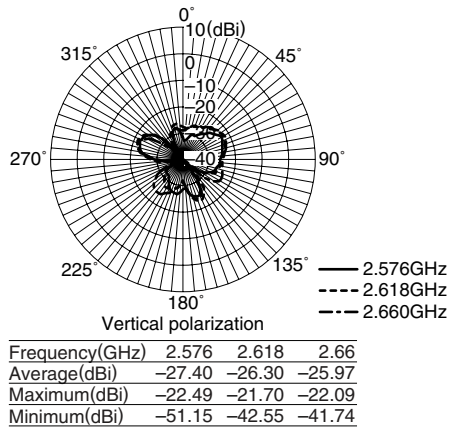
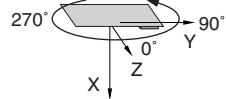
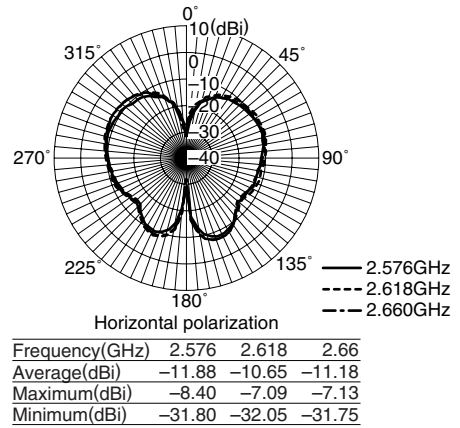
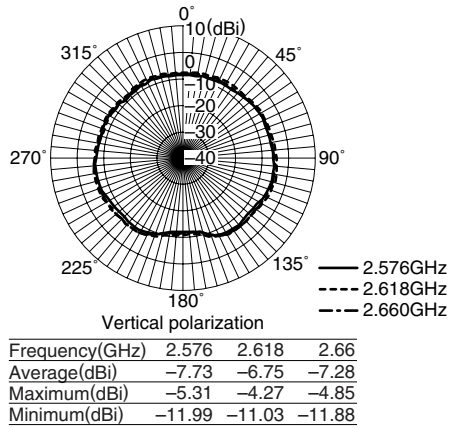
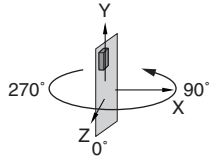
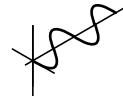

• Tested antenna has been soldered.

• All specifications are subject to change without notice.

# Ceramic Chip Antennas For 2.4GHz ISM band

Conformity to RoHS Directive

ANT Series ANT040015CCS2442MA1

## SHAPES AND DIMENSIONS

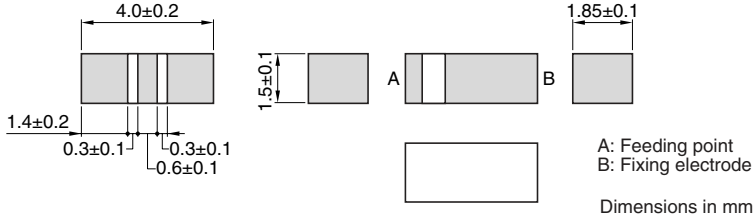

## RECOMMENDED PC BOARD PATTERNS ELECTRODE

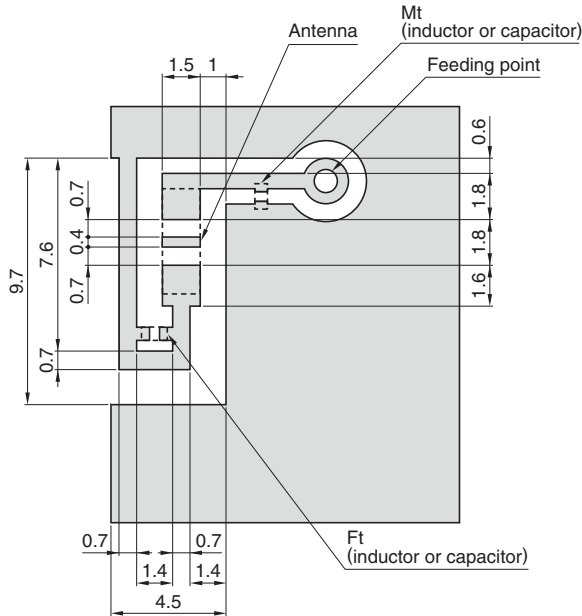

## SOLDER RESIST

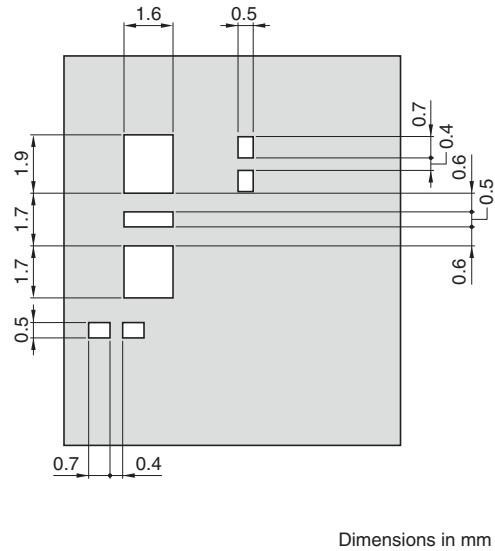

## ELECTRICAL CHARACTERISTICS

|                                   |                        |
|-----------------------------------|------------------------|
| Center frequency(F <sub>0</sub> ) | 2442MHz                |
| Band width(BW)                    | F <sub>0</sub> ±42MHz  |
| VSWR(at BW)                       | 3.5max.                |
| Polarization                      | Linear                 |
| Impedance                         | 50Ω                    |
| PCB size                          | 80×37×1.0mm            |
| Temperature range                 | Operating -40 to +85°C |
|                                   | Storage -40 to +85°C   |

• This is typical antenna performance with the standard PCB.

## FREQUENCY CHARACTERISTICS

### EFFICIENCY AND VSWR

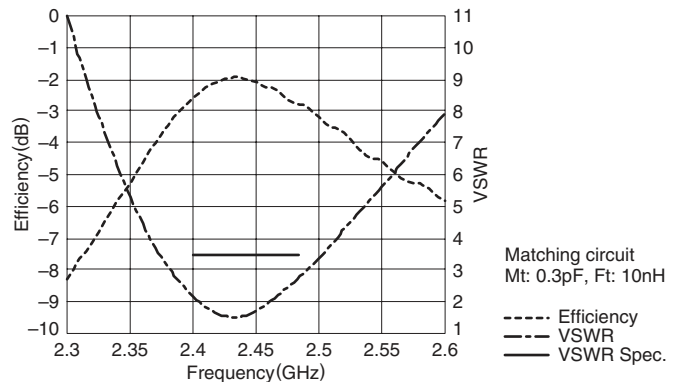

• Conformity to RoHS Directive: This means that, in conformity with EU Directive 2002/95/EC, lead, cadmium, mercury, hexavalent chromium, and specific bromine-based flame retardants, PBB and PBDE, have not been used, except for exempted applications.

• All specifications are subject to change without notice.

**RADIATION PATTERNS**  
**ANT040015CCS2442MA1**

Directivity angle

Vertical polarization



Horizontal polarization

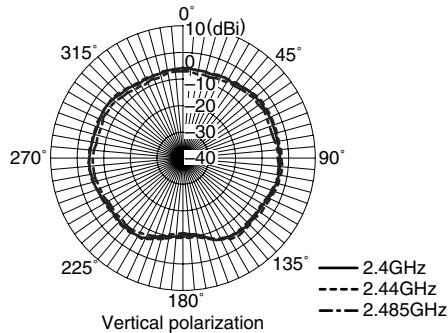
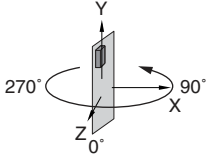
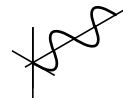

| Frequency(GHz) | 2.4    | 2.44   | 2.485  |
|----------------|--------|--------|--------|
| Average(dBi)   | -5.53  | -5.09  | -6.46  |
| Maximum(dBi)   | -3.17  | -2.50  | -3.68  |
| Minimum(dBi)   | -10.82 | -10.10 | -11.47 |

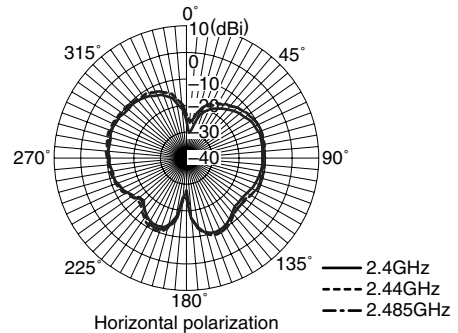

| Frequency(GHz) | 2.4    | 2.44   | 2.485  |
|----------------|--------|--------|--------|
| Average(dBi)   | -12.88 | -11.80 | -12.09 |
| Maximum(dBi)   | -9.95  | -9.02  | -9.07  |
| Minimum(dBi)   | -30.30 | -27.45 | -27.63 |

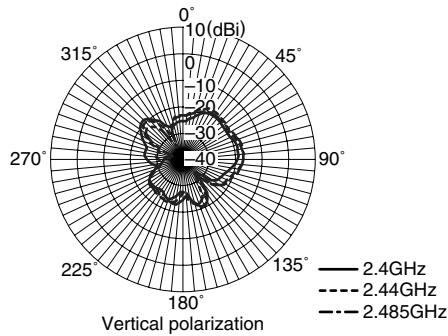
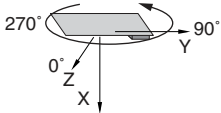

| Frequency(GHz) | 2.4    | 2.44   | 2.485  |
|----------------|--------|--------|--------|
| Average(dBi)   | -22.69 | -21.97 | -22.24 |
| Maximum(dBi)   | -18.95 | -17.00 | -16.96 |
| Minimum(dBi)   | -33.22 | -32.13 | -36.22 |

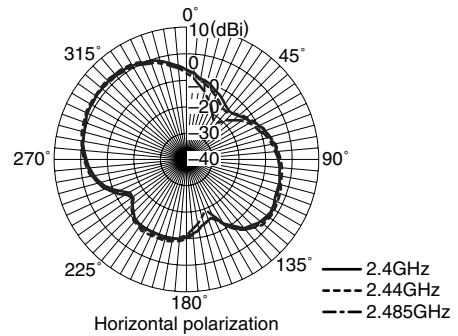

| Frequency(GHz) | 2.4    | 2.44   | 2.485  |
|----------------|--------|--------|--------|
| Average(dBi)   | -4.07  | -3.42  | -4.20  |
| Maximum(dBi)   | 1.71   | 2.32   | 1.59   |
| Minimum(dBi)   | -16.05 | -16.62 | -22.00 |

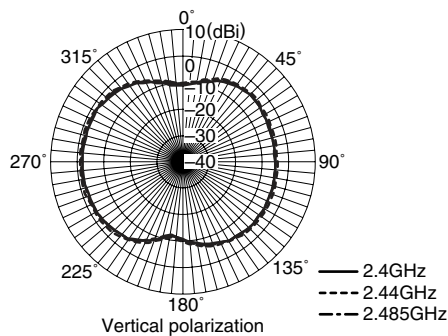
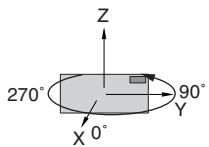

| Frequency(GHz) | 2.4    | 2.44   | 2.485  |
|----------------|--------|--------|--------|
| Average(dBi)   | -4.73  | -3.94  | -4.54  |
| Maximum(dBi)   | -1.98  | -1.17  | -1.61  |
| Minimum(dBi)   | -11.61 | -10.94 | -12.00 |

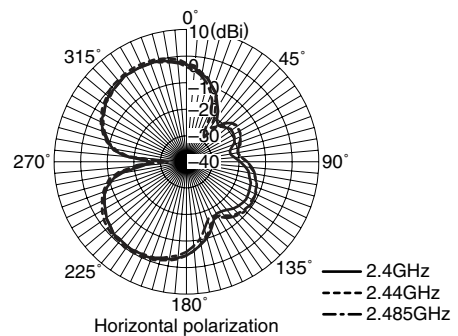

| Frequency(GHz) | 2.4    | 2.44   | 2.485  |
|----------------|--------|--------|--------|
| Average(dBi)   | -5.33  | -4.56  | -5.61  |
| Maximum(dBi)   | -0.08  | 0.72   | -0.26  |
| Minimum(dBi)   | -26.23 | -30.96 | -32.81 |

• Tested antenna has been soldered.

• All specifications are subject to change without notice.

# Ceramic Chip Antennas For 2.4GHz ISM band

Conformity to RoHS Directive

ANT Series ANT098030CGS2442MA1

## SHAPES AND DIMENSIONS

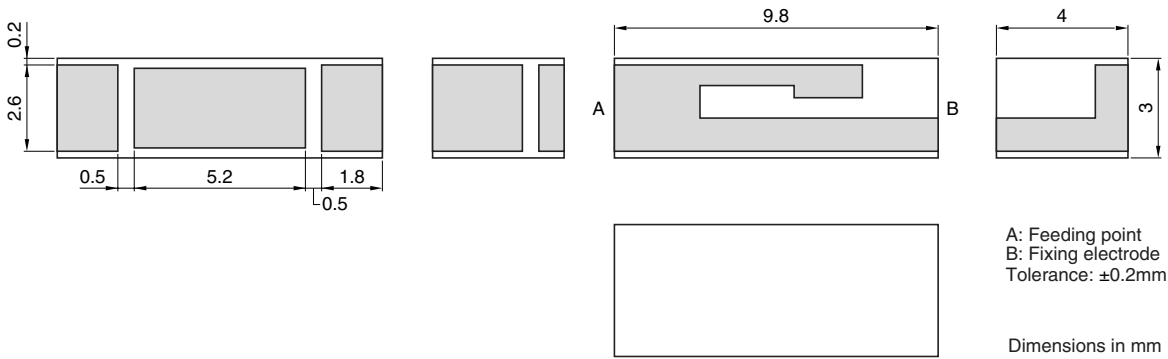

## RECOMMENDED PC BOARD PATTERNS ELECTRODE

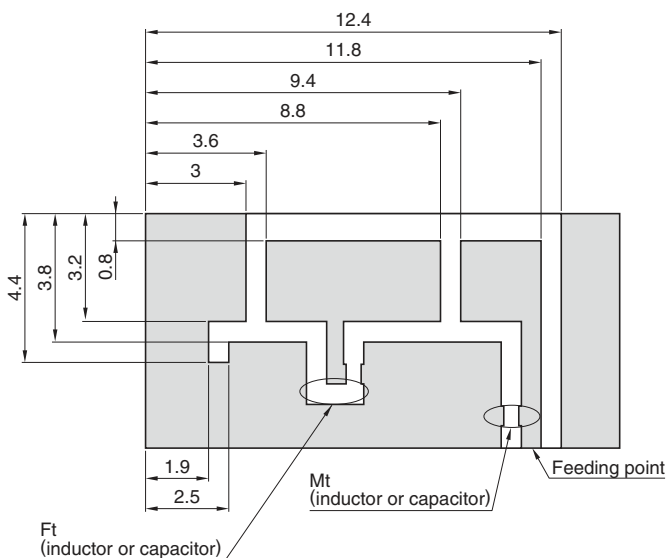

## SOLDER RESIST

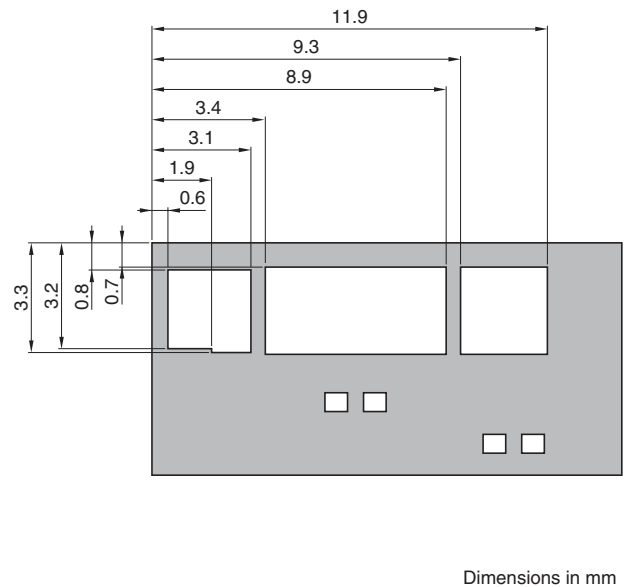

## ELECTRICAL CHARACTERISTICS

|                           |  |
|---------------------------|--|
| Center frequency( $F_0$ ) | 2442MHz  |
| Band width(BW)            | $F_0 \pm 42\text{MHz}$   |
| VSWR(at BW)               | 3.7max.  |
| Polarization              | Linear   |
| Impedance                 | $50\Omega$   |
| PCB size                  | $80 \times 37 \times 1.0\text{mm}$   |
| Temperature range         | Operating: $-40$ to $+85^\circ\text{C}$<br>Storage: $-40$ to $+85^\circ\text{C}$ |

• This is typical antenna performance with the standard PCB.

## FREQUENCY CHARACTERISTICS

### EFFICIENCY AND VSWR

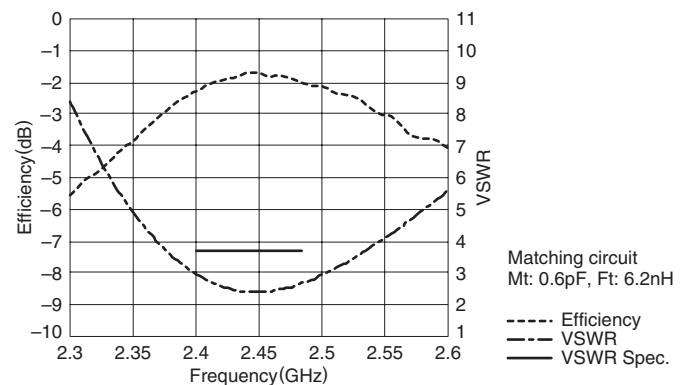

• Conformity to RoHS Directive: This means that, in conformity with EU Directive 2002/95/EC, lead, cadmium, mercury, hexavalent chromium, and specific bromine-based flame retardants, PBB and PBDE, have not been used, except for exempted applications.

• All specifications are subject to change without notice.



**RADIATION PATTERNS**  
**ANT098030CGS2442MA1**

Directivity angle

Vertical polarization



Horizontal polarization

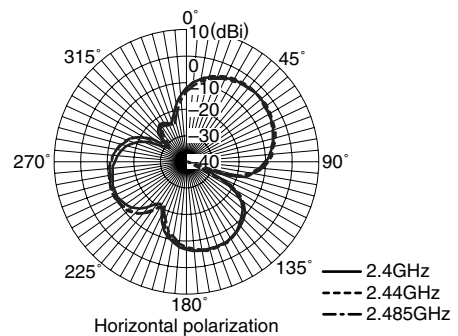
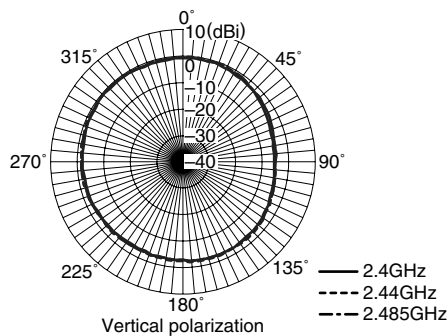
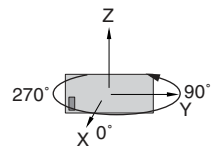
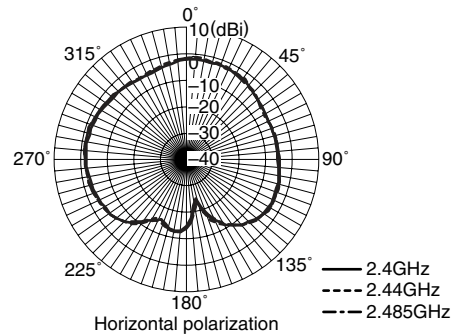
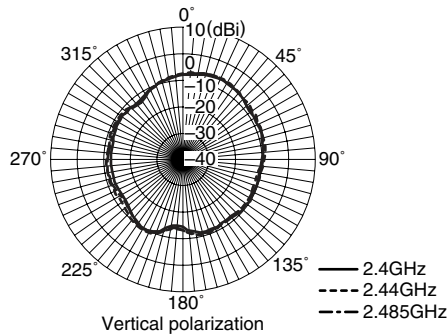
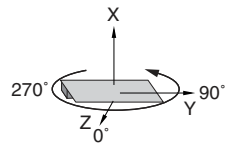
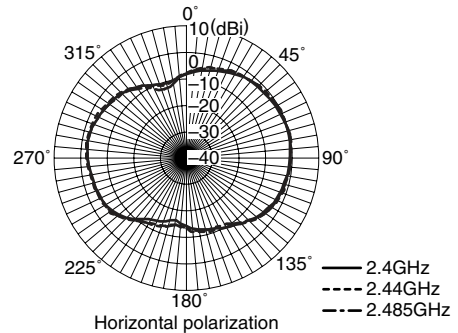
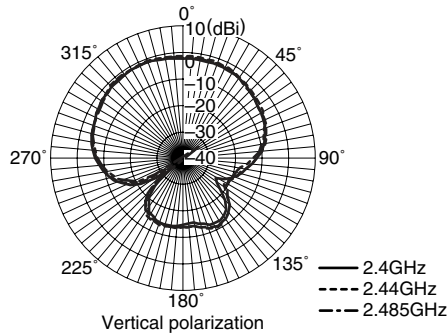
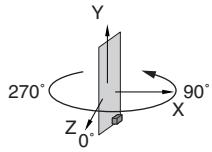
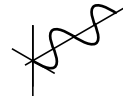

• Tested antenna has been soldered.

• All specifications are subject to change without notice.

# Ceramic Chip Antennas For 2.4GHz ISM band

Conformity to RoHS Directive

ANT Series ANT098030CGS2442MB1

## SHAPES AND DIMENSIONS

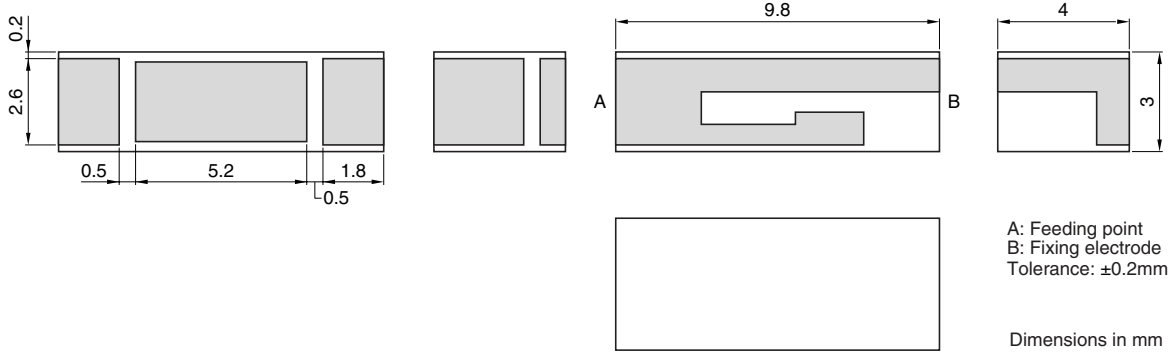

## RECOMMENDED PC BOARD PATTERNS ELECTRODE

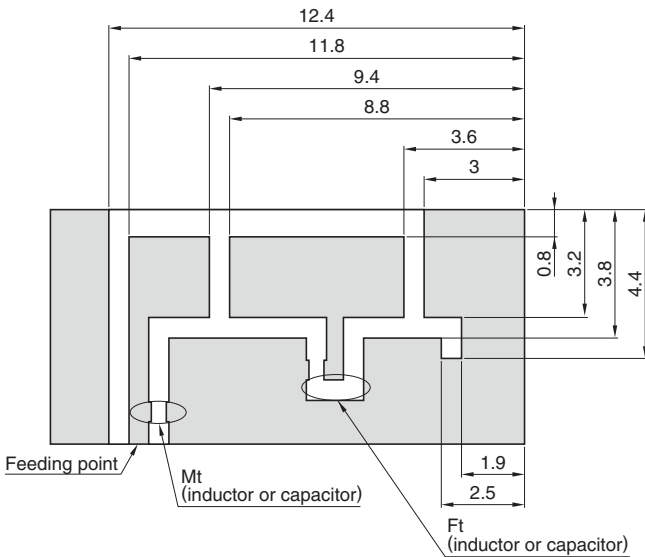

## SOLDER RESIST

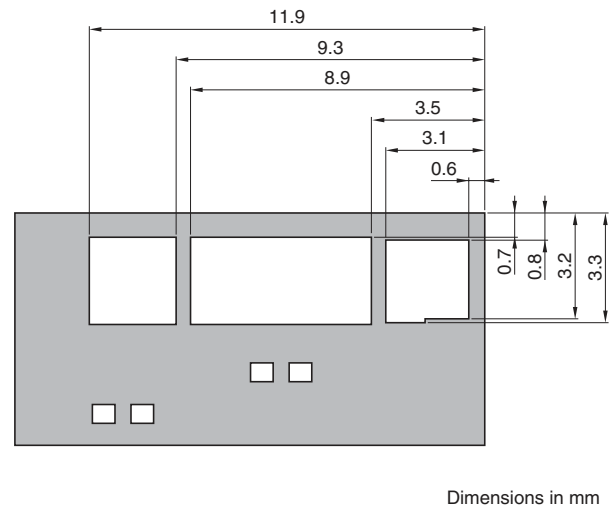

## ELECTRICAL CHARACTERISTICS

|                           |  |
|---------------------------|--|
| Center frequency( $F_0$ ) | 2442MHz  |
| Band width(BW)            | $F_0 \pm 42$ MHz   |
| VSWR(at BW)               | 3.7max.  |
| Polarization              | Linear   |
| Impedance                 | $50\Omega$   |
| PCB size                  | $80 \times 37 \times 1.0$ mm   |
| Temperature range         | Operating: $-40$ to $+85^\circ\text{C}$<br>Storage: $-40$ to $+85^\circ\text{C}$ |

• This is typical antenna performance with the standard PCB.

## FREQUENCY CHARACTERISTICS

### EFFICIENCY AND VSWR

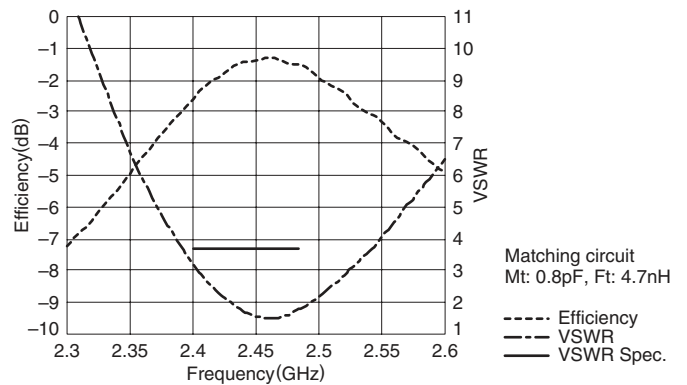

• Conformity to RoHS Directive: This means that, in conformity with EU Directive 2002/95/EC, lead, cadmium, mercury, hexavalent chromium, and specific bromine-based flame retardants, PBB and PBDE, have not been used, except for exempted applications.

• All specifications are subject to change without notice.

**RADIATION PATTERNS**  
**ANT098030CGS2442MB1**

Directivity angle

Vertical polarization



Horizontal polarization

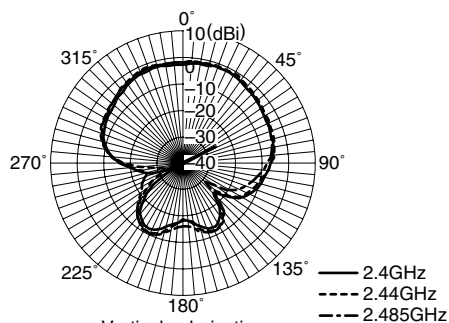
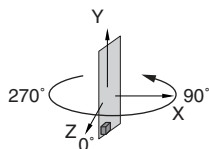

Vertical polarization

| Frequency(GHz) | 2.4    | 2.44   | 2.485  |
|----------------|--------|--------|--------|
| Average(dBi)   | -6.61  | -5.82  | -6.19  |
| Maximum(dBi)   | -1.61  | -0.92  | -1.36  |
| Minimum(dBi)   | -53.65 | -33.24 | -29.04 |

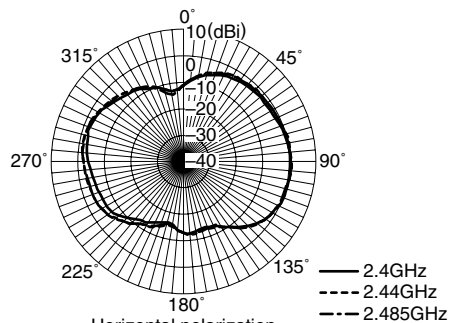

Horizontal polarization

| Frequency(GHz) | 2.4    | 2.44   | 2.485  |
|----------------|--------|--------|--------|
| Average(dBi)   | -4.34  | -3.54  | -3.78  |
| Maximum(dBi)   | 0.54   | 0.68   | 0.36   |
| Minimum(dBi)   | -16.28 | -15.12 | -15.44 |

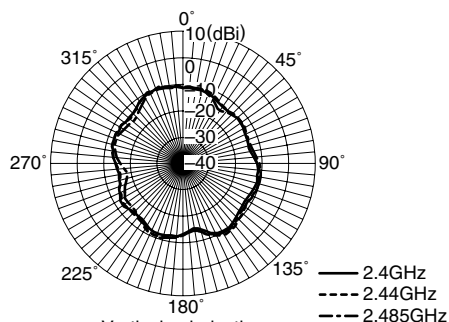
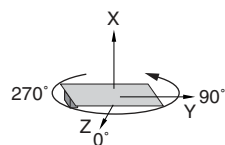

Vertical polarization

| Frequency(GHz) | 2.4    | 2.44   | 2.485  |
|----------------|--------|--------|--------|
| Average(dBi)   | -12.42 | -11.92 | -12.48 |
| Maximum(dBi)   | -10.02 | -8.90  | -9.89  |
| Minimum(dBi)   | -15.55 | -15.77 | -18.54 |

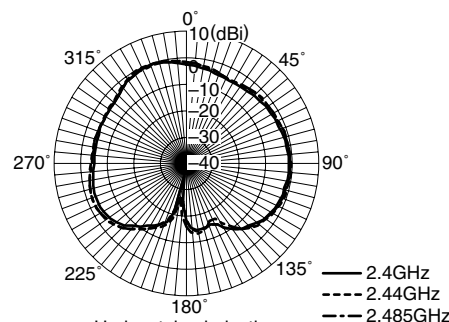

Horizontal polarization

| Frequency(GHz) | 2.4    | 2.44   | 2.485  |
|----------------|--------|--------|--------|
| Average(dBi)   | -4.14  | -3.34  | -3.61  |
| Maximum(dBi)   | -0.43  | 0.01   | -0.66  |
| Minimum(dBi)   | -35.27 | -26.02 | -26.84 |

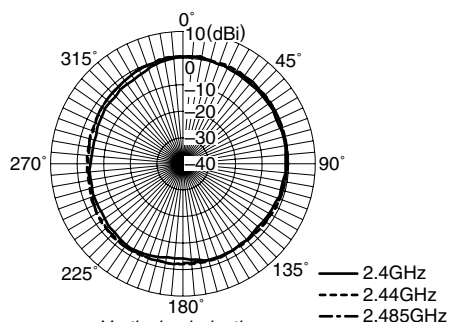
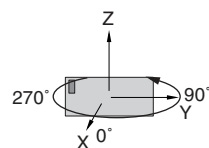

Vertical polarization

| Frequency(GHz) | 2.4   | 2.44  | 2.485 |
|----------------|-------|-------|-------|
| Average(dBi)   | -2.13 | -1.21 | -1.38 |
| Maximum(dBi)   | 0.56  | 0.74  | 0.36  |
| Minimum(dBi)   | -5.55 | -3.95 | -4.27 |

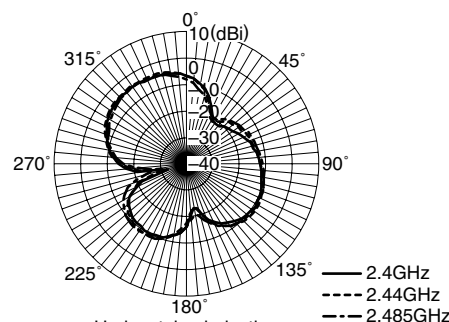

Horizontal polarization

| Frequency(GHz) | 2.4    | 2.44   | 2.485  |
|----------------|--------|--------|--------|
| Average(dBi)   | -9.94  | -9.32  | -9.88  |
| Maximum(dBi)   | -4.70  | -3.94  | -4.62  |
| Minimum(dBi)   | -32.34 | -31.36 | -26.68 |

• Tested antenna has been soldered.

• All specifications are subject to change without notice.