



MICROCHIP

PIC32MX3XX/4XX

Data Sheet

High-Performance,
General Purpose and USB,
32-bit Flash Microcontrollers

Note the following details of the code protection feature on Microchip devices:

- Microchip products meet the specification contained in their particular Microchip Data Sheet.
- Microchip believes that its family of products is one of the most secure families of its kind on the market today, when used in the intended manner and under normal conditions.
- There are dishonest and possibly illegal methods used to breach the code protection feature. All of these methods, to our knowledge, require using the Microchip products in a manner outside the operating specifications contained in Microchip's Data Sheets. Most likely, the person doing so is engaged in theft of intellectual property.
- Microchip is willing to work with the customer who is concerned about the integrity of their code.
- Neither Microchip nor any other semiconductor manufacturer can guarantee the security of their code. Code protection does not mean that we are guaranteeing the product as "unbreakable."

Code protection is constantly evolving. We at Microchip are committed to continuously improving the code protection features of our products. Attempts to break Microchip's code protection feature may be a violation of the Digital Millennium Copyright Act. If such acts allow unauthorized access to your software or other copyrighted work, you may have a right to sue for relief under that Act.

Information contained in this publication regarding device applications and the like is provided only for your convenience and may be superseded by updates. It is your responsibility to ensure that your application meets with your specifications. MICROCHIP MAKES NO REPRESENTATIONS OR WARRANTIES OF ANY KIND WHETHER EXPRESS OR IMPLIED, WRITTEN OR ORAL, STATUTORY OR OTHERWISE, RELATED TO THE INFORMATION, INCLUDING BUT NOT LIMITED TO ITS CONDITION, QUALITY, PERFORMANCE, MERCHANTABILITY OR FITNESS FOR PURPOSE. Microchip disclaims all liability arising from this information and its use. Use of Microchip devices in life support and/or safety applications is entirely at the buyer's risk, and the buyer agrees to defend, indemnify and hold harmless Microchip from any and all damages, claims, suits, or expenses resulting from such use. No licenses are conveyed, implicitly or otherwise, under any Microchip intellectual property rights.

Trademarks

The Microchip name and logo, the Microchip logo, dsPIC, KEELOQ, KEELOQ logo, MPLAB, PIC, PICmicro, PICSTART, PIC³² logo, rPIC and UNI/O are registered trademarks of Microchip Technology Incorporated in the U.S.A. and other countries.

FilterLab, Hampshire, HI-TECH C, Linear Active Thermistor, MXDEV, MXLAB, SEEVAL and The Embedded Control Solutions Company are registered trademarks of Microchip Technology Incorporated in the U.S.A.

Analog-for-the-Digital Age, Application Maestro, CodeGuard, dsPICDEM, dsPICDEM.net, dsPICworks, dsSPEAK, ECAN, ECONOMONITOR, FanSense, HI-TIDE, In-Circuit Serial Programming, ICSP, Mindi, MiWi, MPASM, MPLAB Certified logo, MPLIB, MPLINK, mTouch, Omniscient Code Generation, PICC, PICC-18, PICDEM, PICDEM.net, PICKit, PICtail, REAL ICE, rLAB, Select Mode, Total Endurance, TSHARC, UniWinDriver, WiperLock and ZENA are trademarks of Microchip Technology Incorporated in the U.S.A. and other countries.

SQTP is a service mark of Microchip Technology Incorporated in the U.S.A.

All other trademarks mentioned herein are property of their respective companies.

© 2011, Microchip Technology Incorporated, Printed in the U.S.A., All Rights Reserved.

 Printed on recycled paper.

ISBN: 978-1-61341-149-0

Microchip received ISO/TS-16949:2002 certification for its worldwide headquarters, design and wafer fabrication facilities in Chandler and Tempe, Arizona; Gresham, Oregon and design centers in California and India. The Company's quality system processes and procedures are for its PIC[®] MCUs and dsPIC[®] DSCs, KEELOQ[®] code hopping devices, Serial EEPROMs, microperipherals, nonvolatile memory and analog products. In addition, Microchip's quality system for the design and manufacture of development systems is ISO 9001:2000 certified.

**QUALITY MANAGEMENT SYSTEM
CERTIFIED BY DNV
== ISO/TS 16949:2002 ==**



PIC32MX3XX/4XX

High-Performance, General Purpose and USB 32-bit Flash Microcontrollers

High-Performance 32-bit RISC CPU:

- MIPS32® M4K® 32-bit core with 5-stage pipeline
- 80 MHz maximum frequency
- 1.56 DMIPS/MHz (Dhrystone 2.1) performance at 0 wait state Flash access
- Single-cycle multiply and high-performance divide unit
- MIPS16e® mode for up to 40% smaller code size
- Two sets of 32 core register files (32-bit) to reduce interrupt latency
- Prefetch Cache module to speed execution from Flash

Microcontroller Features:

- Operating temperature range of -40°C to +105°C
- Operating voltage range of 2.3V to 3.6V
- 32K to 512K Flash memory (plus an additional 12 KB of boot Flash)
- 8K to 32K SRAM memory
- Pin-compatible with most PIC24/dsPIC® DSC devices
- Multiple power management modes
- Multiple interrupt vectors with individually programmable priority
- Fail-Safe Clock Monitor Mode
- Configurable Watchdog Timer with on-chip Low-Power RC Oscillator for reliable operation

Peripheral Features:

- Atomic SET, CLEAR and INVERT operation on select peripheral registers
- Up to 4-channel hardware DMA with automatic data size detection
- USB 2.0-compliant full-speed device and On-The-Go (OTG) controller
- USB has a dedicated DMA channel
- 3 MHz to 25 MHz crystal oscillator
- Internal 8 MHz and 32 kHz oscillators

- Separate PLLs for CPU and USB clocks
- Two I²C™ modules
- Two UART modules with:
 - RS-232, RS-485 and LIN support
 - IrDA® with on-chip hardware encoder and decoder
- Up to two SPI modules
- Parallel Master and Slave Port (PMP/PSP) with 8-bit and 16-bit data and up to 16 address lines
- Hardware Real-Time Clock and Calendar (RTCC)
- Five 16-bit Timers/Counters (two 16-bit pairs combine to create two 32-bit timers)
- Five capture inputs
- Five compare/PWM outputs
- Five external interrupt pins
- High-Speed I/O pins capable of toggling at up to 80 MHz
- High-current sink/source (18 mA/18 mA) on all I/O pins
- Configurable open-drain output on digital I/O pins

Debug Features:

- Two programming and debugging Interfaces:
 - 2-wire interface with unintrusive access and real-time data exchange with application
 - 4-wire MIPS® standard enhanced JTAG interface
- Unintrusive hardware-based instruction trace
- IEEE Standard 1149.2-compatible (JTAG) boundary scan

Analog Features:

- Up to 16-channel 10-bit Analog-to-Digital Converter:
 - 1000 ksps conversion rate
 - Conversion available during Sleep, Idle
- Two Analog Comparators

PIC32MX3XX/4XX

TABLE 1: PIC32MX GENERAL PURPOSE – FEATURES

| GENERAL PURPOSE | | | | | | | | | | | | | | |
|-----------------|------|-------------------------|-----|-------------------------|------------------|------------------------|---------------------------|------|-------|-----------------------------|-----------------|-------------|---------|------|
| Device | Pins | Packages ⁽²⁾ | MHz | Program Memory (KB) | Data Memory (KB) | Timers/Capture/Compare | Programmable DMA Channels | VREG | Trace | EUART/SPI/I ² C™ | 10-bit ADC (ch) | Comparators | PMP/PSP | JTAG |
| PIC32MX320F032H | 64 | PT, MR | 40 | 32 + 12 ⁽¹⁾ | 8 | 5/5/5 | 0 | Yes | No | 2/2/2 | 16 | 2 | Yes | Yes |
| PIC32MX320F064H | 64 | PT, MR | 80 | 64 + 12 ⁽¹⁾ | 16 | 5/5/5 | 0 | Yes | No | 2/2/2 | 16 | 2 | Yes | Yes |
| PIC32MX320F128H | 64 | PT, MR | 80 | 128 + 12 ⁽¹⁾ | 16 | 5/5/5 | 0 | Yes | No | 2/2/2 | 16 | 2 | Yes | Yes |
| PIC32MX340F128H | 64 | PT, MR | 80 | 128 + 12 ⁽¹⁾ | 32 | 5/5/5 | 4 | Yes | No | 2/2/2 | 16 | 2 | Yes | Yes |
| PIC32MX340F256H | 64 | PT, MR | 80 | 256 + 12 ⁽¹⁾ | 32 | 5/5/5 | 4 | Yes | No | 2/2/2 | 16 | 2 | Yes | Yes |
| PIC32MX340F512H | 64 | PT, MR | 80 | 512 + 12 ⁽¹⁾ | 32 | 5/5/5 | 4 | Yes | No | 2/2/2 | 16 | 2 | Yes | Yes |
| PIC32MX320F128L | 100 | PT | 80 | 128 + 12 ⁽¹⁾ | 16 | 5/5/5 | 0 | Yes | No | 2/2/2 | 16 | 2 | Yes | Yes |
| | 121 | BG | | | | | | | | | | | | |
| PIC32MX340F128L | 100 | PT | 80 | 128 + 12 ⁽¹⁾ | 32 | 5/5/5 | 4 | Yes | No | 2/2/2 | 16 | 2 | Yes | Yes |
| | 121 | BG | | | | | | | | | | | | |
| PIC32MX360F256L | 100 | PT | 80 | 256 + 12 ⁽¹⁾ | 32 | 5/5/5 | 4 | Yes | Yes | 2/2/2 | 16 | 2 | Yes | Yes |
| | 121 | BG | | | | | | | | | | | | |
| PIC32MX360F512L | 100 | PT | 80 | 512 + 12 ⁽¹⁾ | 32 | 5/5/5 | 4 | Yes | Yes | 2/2/2 | 16 | 2 | Yes | Yes |
| | 121 | BG | | | | | | | | | | | | |

Legend: PT = TQFP MR = QFN BG = XBGA

Note 1: This device features 12 KB Boot Flash memory.

Note 2: See Legend for an explanation of the acronyms. See [Section 30.0 “Packaging Information”](#) for details.

TABLE 2: PIC32MX USB – FEATURES

| USB | | | | | | | | | | | | | | | |
|-----------------|------|-------------------------|-----|-------------------------|------------------|------------------------|---------------------------|----------------------------|------|-------|-----------------------------|-----------------|-------------|---------|------|
| Device | Pins | Packages ⁽²⁾ | MHz | Program Memory (KB) | Data Memory (KB) | Timers/Capture/Compare | Programmable DMA Channels | Dedicated USB DMA Channels | VREG | Trace | EUART/SPI/I ² C™ | 10-bit ADC (ch) | Comparators | PMP/PSP | JTAG |
| PIC32MX420F032H | 64 | PT, MR | 40 | 32 + 12 ⁽¹⁾ | 8 | 5/5/5 | 0 | 2 | Yes | No | 2/1/2 | 16 | 2 | Yes | Yes |
| PIC32MX440F128H | 64 | PT, MR | 80 | 128 + 12 ⁽¹⁾ | 32 | 5/5/5 | 4 | 2 | Yes | No | 2/1/2 | 16 | 2 | Yes | Yes |
| PIC32MX440F256H | 64 | PT, MR | 80 | 256 + 12 ⁽¹⁾ | 32 | 5/5/5 | 4 | 2 | Yes | No | 2/1/2 | 16 | 2 | Yes | Yes |
| PIC32MX440F512H | 64 | PT, MR | 80 | 512 + 12 ⁽¹⁾ | 32 | 5/5/5 | 4 | 2 | Yes | No | 2/1/2 | 16 | 2 | Yes | Yes |
| PIC32MX440F128L | 100 | PT | 80 | 128 + 12 ⁽¹⁾ | 32 | 5/5/5 | 4 | 2 | Yes | No | 2/2/2 | 16 | 2 | Yes | Yes |
| | 121 | BG | | | | | | | | | | | | | |
| PIC32MX460F256L | 100 | PT | 80 | 256 + 12 ⁽¹⁾ | 32 | 5/5/5 | 4 | 2 | Yes | Yes | 2/2/2 | 16 | 2 | Yes | Yes |
| | 121 | BG | | | | | | | | | | | | | |
| PIC32MX460F512L | 100 | PT | 80 | 512 + 12 ⁽¹⁾ | 32 | 5/5/5 | 4 | 2 | Yes | Yes | 2/2/2 | 16 | 2 | Yes | Yes |
| | 121 | BG | | | | | | | | | | | | | |

Legend: PT = TQFP MR = QFN BG = XBGA

Note 1: This device features 12 KB Boot Flash memory.

Note 2: See Legend for an explanation of the acronyms. See [Section 30.0 “Packaging Information”](#) for details.

PIC32MX3XX/4XX

Pin Diagrams

64-Pin QFN (General Purpose)

■ = Pins are up to 5V tolerant

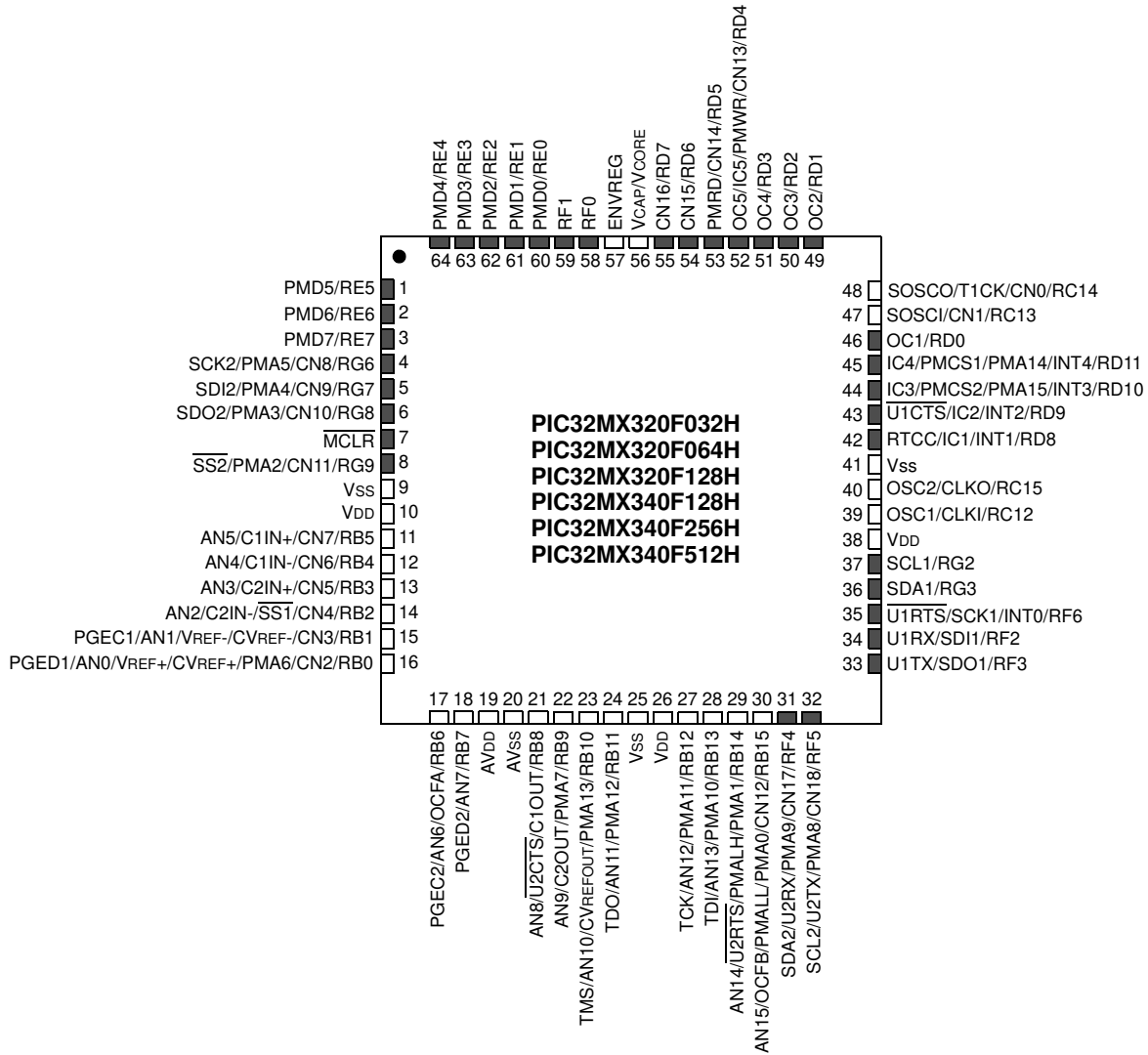

Note: The metal plane at the bottom of the device is not connected to any pins and is recommended to be connected to VSS externally.

Pin Diagrams (Continued)

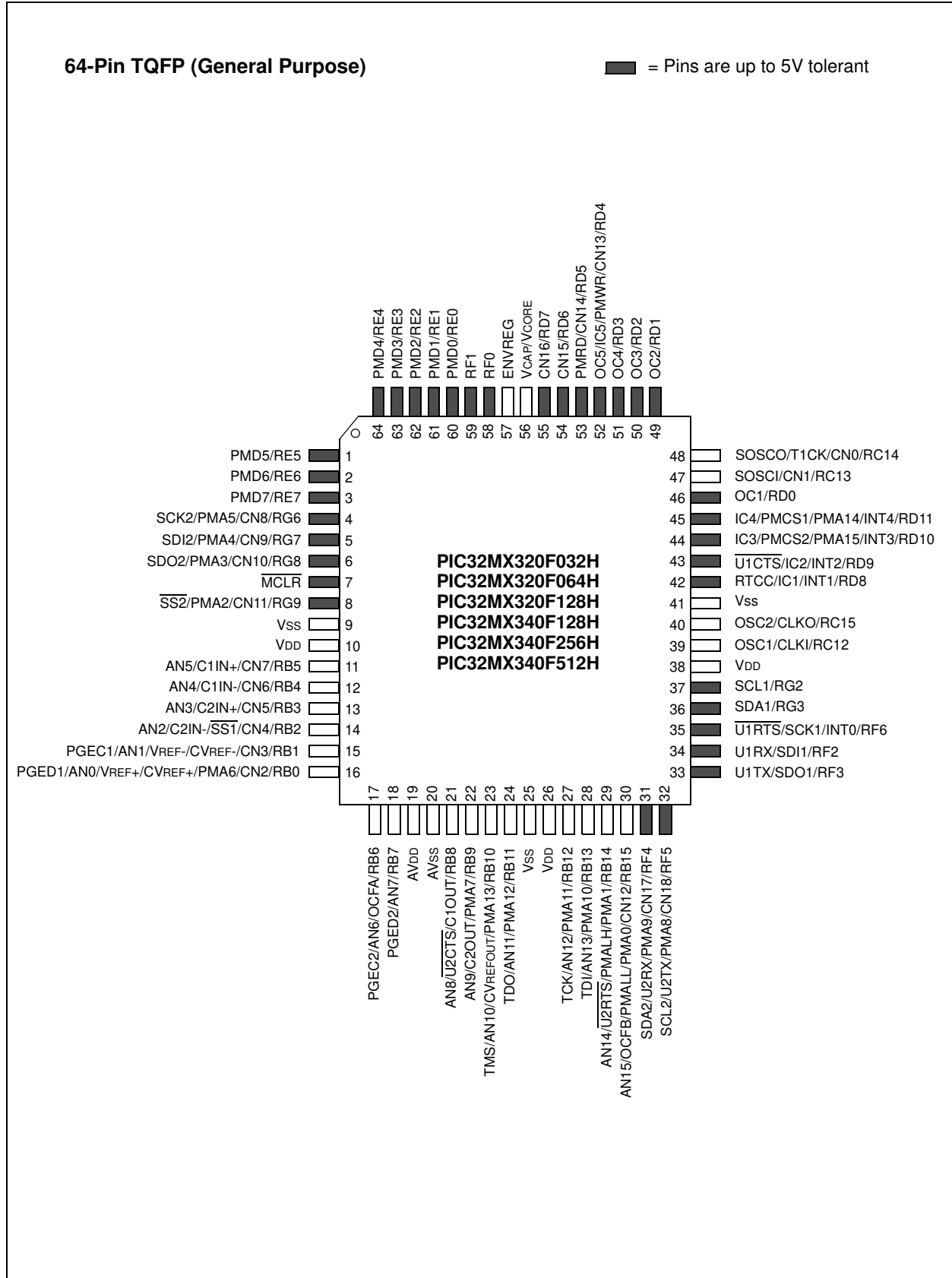

PIC32MX3XX/4XX

Pin Diagrams (Continued)

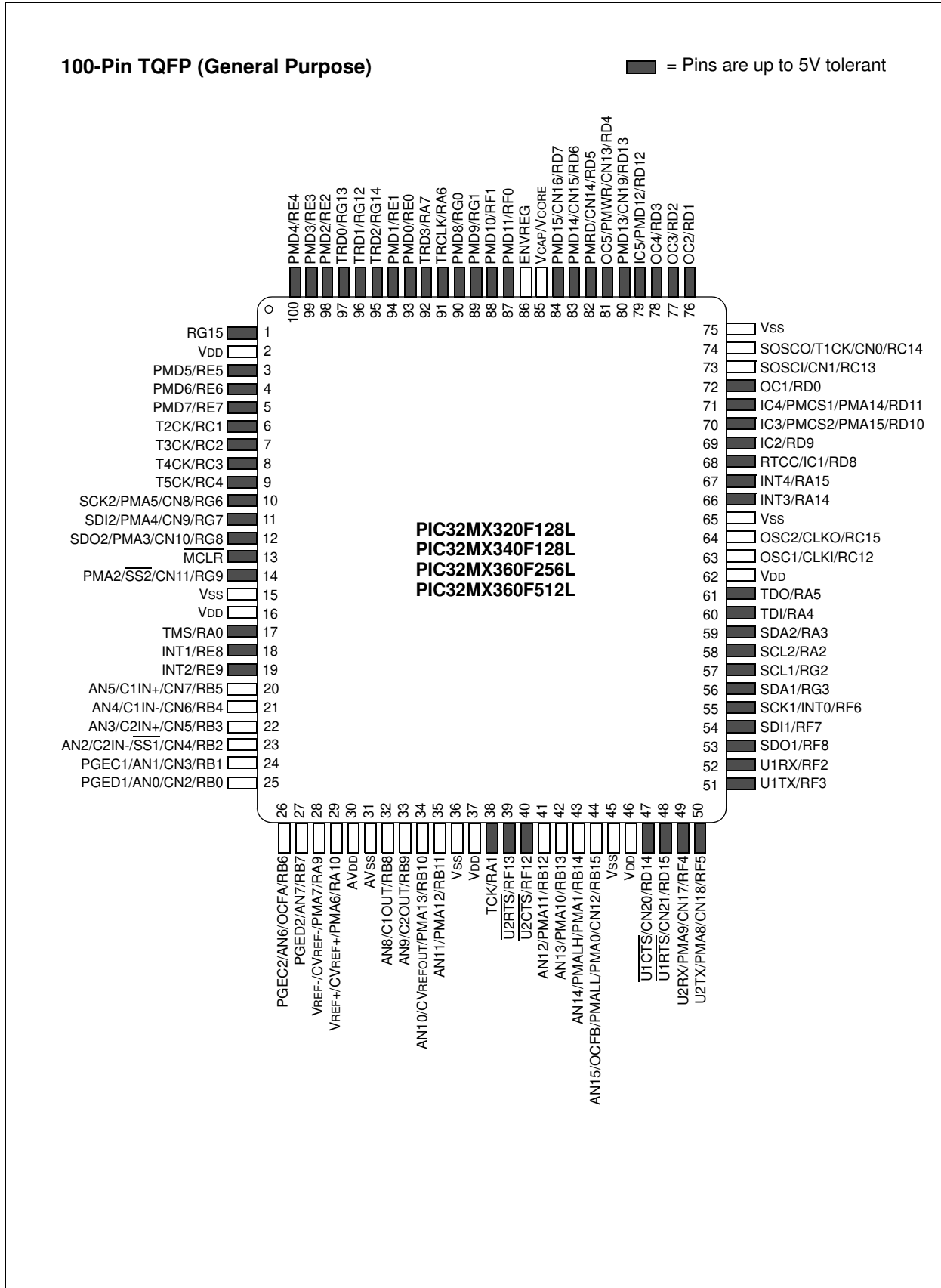

Pin Diagrams (Continued)

121-Pin XBGA⁽¹⁾

● = Pins are up to 5V tolerant

PIC32MX320F128L
 PIC32MX340F128L
 PIC32MX360F256L
 PIC32MX360F512L

| | 1 | 2 | 3 | 4 | 5 | 6 | 7 | 8 | 9 | 10 | 11 |
|----------|-----------|----------------------|-----------|-----------------------|----------------------|----------------------|--|----------------------|----------------------|-----------|-----------|
| A | ● RE4 | ● RE3 | ● RG13 | ● RE0 | ● RG0 | ● RF1 | ○ ENVREG | ○ Vss | ● RD12 | ● RD2 | ● RD1 |
| B | ● NC | ● RG15 | ● RE2 | ● RE1 | ● RA7 | ● RF0 | ○ V _{CORE} / V _{CAP} | ● RD5 | ● RD3 | ○ Vss | ○ RC14 |
| C | ● RE6 | ○ V _{DD} | ● RG12 | ● RG14 | ● RA6 | ● NC | ● RD7 | ● RD4 | ○ V _{DD} | ○ RC13 | ● RD11 |
| D | ● RC1 | ● RE7 | ● RE5 | ○ Vss | ○ Vss | ● NC | ● RD6 | ● RD13 | ● RD0 | ○ NC | ● RD10 |
| E | ● RC4 | ● RC3 | ● RG6 | ● RC2 | ○ V _{DD} | ● RG1 | ○ Vss | ● RA15 | ● RD8 | ● RD9 | ● RA14 |
| F | ● MCLR | ● RG8 | ● RG9 | ● RG7 | ○ Vss | ● NC | ● NC | ○ V _{DD} | ○ RC12 | ○ Vss | ○ RC15 |
| G | ● RE8 | ● RE9 | ● RA0 | ○ NC | ○ V _{DD} | ○ Vss | ○ Vss | ● NC | ● RA5 | ● RA3 | ● RA4 |
| H | ○ RB5 | ○ RB4 | ○ Vss | ○ V _{DD} | ● NC | ○ V _{DD} | ● NC | ● RF7 | ● RF6 | ● RG2 | ● RA2 |
| J | ○ RB3 | ○ RB2 | ○ RB7 | ○ AV _{DD} | ○ RB11 | ○ RA1 | ○ RB12 | ● NC | ○ NC | ● RF8 | ○ RG3 |
| K | ○ RB1 | ○ RB0 | ○ RA10 | ○ RB8 | ● NC | ● RF12 | ○ RB14 | ○ V _{DD} | ● RD15 | ● RF3 | ● RF2 |
| L | ○ RB6 | ○ RA9 | ○ AVss | ○ RB9 | ○ RB10 | ● RF13 | ○ RB13 | ○ RB15 | ● RD14 | ● RF4 | ● RF5 |

Note 1: Refer to [Table 3](#) for full pin names.

PIC32MX3XX/4XX

TABLE 3: PIN NAMES: PIC32MX320F128L, PIC32MX340F128L, PIC32MX360F128L, AND PIC32MX360F512L DEVICES

| Pin Number | Full Pin Name |
|------------|----------------------|
| A1 | PMD4/RE4 |
| A2 | PMD3/RE3 |
| A3 | TRD0/RG13 |
| A4 | PMD0/RE0 |
| A5 | PMD8/RG0 |
| A6 | PMD10/RF1 |
| A7 | ENVREG |
| A8 | Vss |
| A9 | IC5/PMD12/RD12 |
| A10 | OC3/RD2 |
| A11 | OC2/RD1 |
| B1 | No Connect (NC) |
| B2 | RG15 |
| B3 | PMD2/RE2 |
| B4 | PMD1/RE1 |
| B5 | TRD3/RA7 |
| B6 | PMD11/RF0 |
| B7 | VCAP/VCORE |
| B8 | PMRD/CN14/RD5 |
| B9 | OC4/RD3 |
| B10 | Vss |
| B11 | SOSCO/T1CK/CN0/RC14 |
| C1 | PMD6/RE6 |
| C2 | VDD |
| C3 | TRD1/RG12 |
| C4 | TRD2/RG14 |
| C5 | TRCLK/RA6 |
| C6 | No Connect (NC) |
| C7 | PMD15/CN16/RD7 |
| C8 | OC5/PMWR/CN13/RD4 |
| C9 | VDD |
| C10 | SOSCI/CN1/RC13 |
| C11 | IC4/PMCS1/PMA14/RD11 |
| D1 | T2CK/RC1 |
| D2 | PMD7/RE7 |
| D3 | PMD5/RE5 |
| D4 | Vss |
| D5 | Vss |
| D6 | No Connect (NC) |
| D7 | PMD14/CN15/RD6 |
| D8 | PMD13/CN19/RD13 |
| D9 | OC1/RD0 |
| D10 | No Connect (NC) |
| D11 | IC3/PMCS2/PMA15/RD10 |
| E1 | T5CK/RC4 |
| E2 | T4CK/RC3 |
| E3 | SCK2/PMA5/CN8/RG6 |
| E4 | T3CK/RC2 |
| E5 | VDD |
| E6 | PMD9/RG1 |
| E7 | Vss |

| Pin Number | Full Pin Name |
|------------|------------------------|
| E8 | INT4/RA15 |
| E9 | RTCC/IC1/RD8 |
| E10 | IC2/RD9 |
| E11 | INT3/RA14 |
| F1 | MCLR |
| F2 | SDO2/PMA3/CN10/RG8 |
| F3 | SS2/PMA2/CN11/RG9 |
| F4 | SDI2/PMA4/CN9/RG7 |
| F5 | Vss |
| F6 | No Connect (NC) |
| F7 | No Connect (NC) |
| F8 | VDD |
| F9 | OSC1/CLKI/RC12 |
| F10 | Vss |
| F11 | OSC2/CLKO/RC15 |
| G1 | INT1/RE8 |
| G2 | INT2/RE9 |
| G3 | TMS/RA0 |
| G4 | No Connect (NC) |
| G5 | VDD |
| G6 | Vss |
| G7 | Vss |
| G8 | No Connect (NC) |
| G9 | TDO/RA5 |
| G10 | SDA2/RA3 |
| G11 | TDI/RA4 |
| H1 | AN5/C1IN+/CN7/RB5 |
| H2 | AN4/C1IN-/CN6/RB4 |
| H3 | Vss |
| H4 | VDD |
| H5 | No Connect (NC) |
| H6 | VDD |
| H7 | No Connect (NC) |
| H8 | SDI1/RF7 |
| H9 | SCK1/INT0/RF6 |
| H10 | SCL1/RG2 |
| H11 | SCL2/RA2 |
| J1 | AN3/C2IN+/CN5/RB3 |
| J2 | AN2/C2IN-/SS1/CN4/RB2 |
| J3 | PGED2/AN7/RB7 |
| J4 | AVDD |
| J5 | AN11/PMA12/RB11 |
| J6 | TCK/RA1 |
| J7 | AN12/PMA11/RB12 |
| J8 | No Connect (NC) |
| J9 | No Connect (NC) |
| J10 | SDO1/RF8 |
| J11 | SDA1/RG3 |
| K1 | PGEC1/AN1/CN3/RB1 |
| K2 | PGED1/AN0/CN2/RB0 |
| K3 | VREF+/CVREF+/PMA6/RA10 |

TABLE 3: PIN NAMES: PIC32MX320F128L, PIC32MX340F128L, PIC32MX360F128L, AND PIC32MX360F512L DEVICES (CONTINUED)

| Pin Number | Full Pin Name |
|------------|-------------------------------|
| K4 | AN8/C1OUT/RB8 |
| K5 | No Connect (NC) |
| K6 | $\overline{U2CTS}$ /RF12 |
| K7 | AN14/PMALH/PMA1/RB14 |
| K8 | VDD |
| K9 | $\overline{U1RTS}$ /CN21/RD15 |
| K10 | U1TX/RF3 |
| K11 | U1RX/RF2 |
| L1 | PGEC2/AN6/OCFA/RB6 |
| L2 | VREF-/CVREF-/PMA7/RA9 |

| Pin Number | Full Pin Name |
|------------|--------------------------------|
| L3 | AVSS |
| L4 | AN9/C2OUT/RB9 |
| L5 | AN10/CVREFOUT/PMA13/RB10 |
| L6 | $\overline{U2RTS}$ /RF13 |
| L7 | AN13/PMA10/RB13 |
| L8 | AN15/OCFB/PMALL/PMA0/CN12/RB15 |
| L9 | CN20/ $\overline{U1CTS}$ /RD14 |
| L10 | U2RX/PMA9/CN17/RF4 |
| L11 | U2TX/PMA8/CN18/RF5 |

PIC32MX3XX/4XX

Pin Diagrams (Continued)

64-Pin QFN (USB)

■ = Pins are up to 5V tolerant

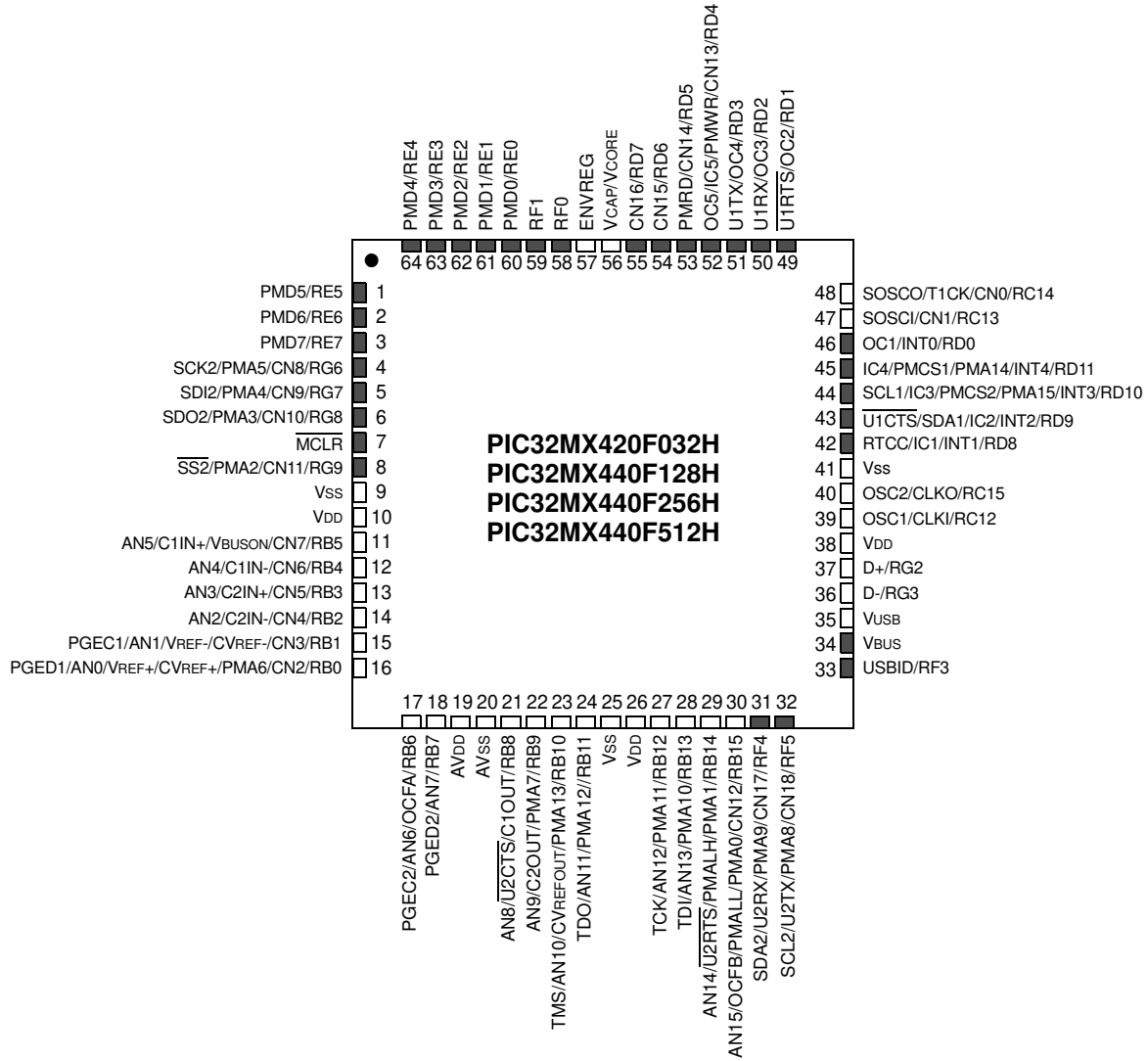

Note: The metal plane at the bottom of the device is not connected to any pins and is recommended to be connected to Vss externally.

Pin Diagrams (Continued)

64-Pin TQFP (USB)

■ = Pins are up to 5V tolerant

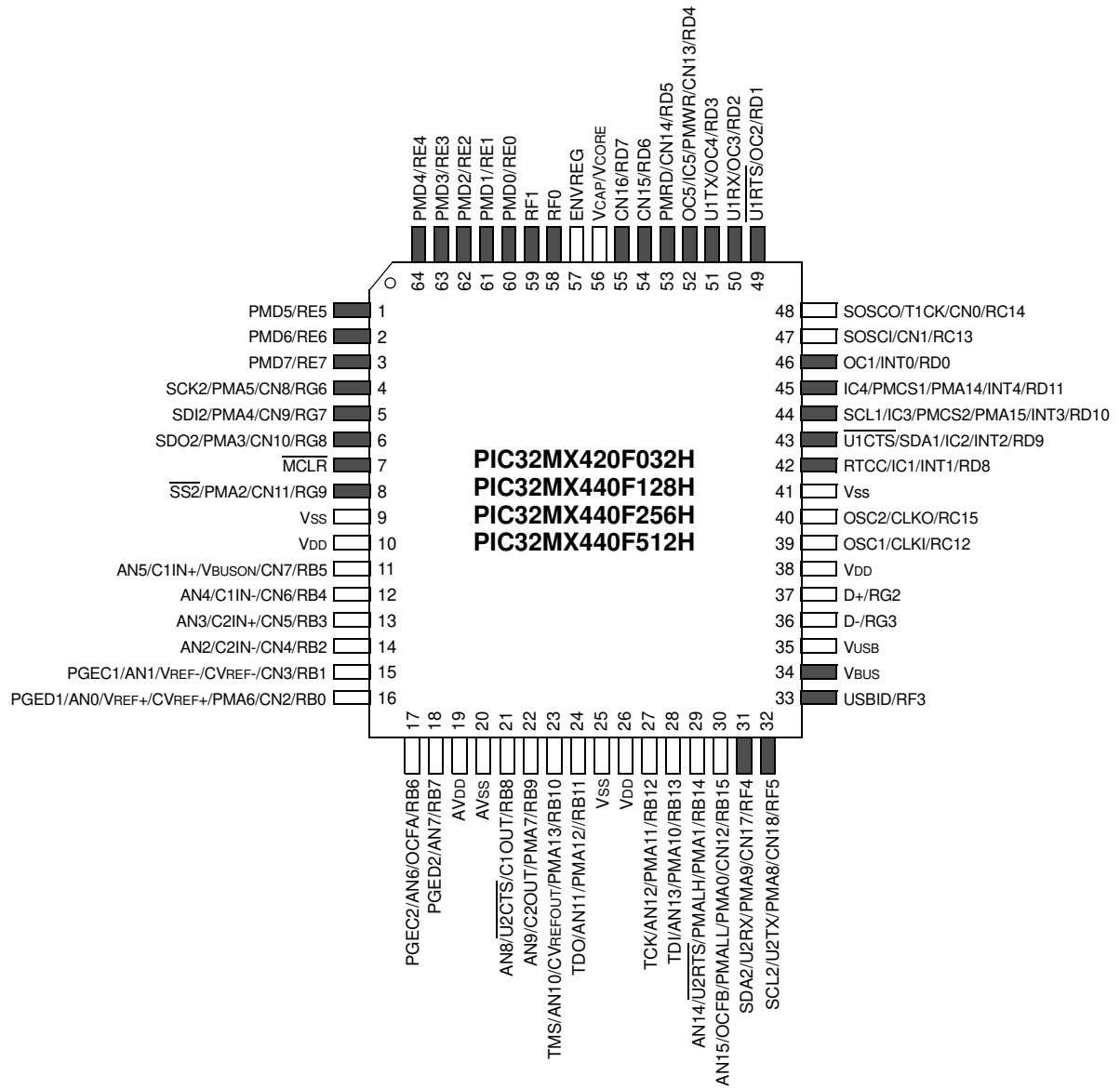

PIC32MX3XX/4XX

Pin Diagrams (Continued)

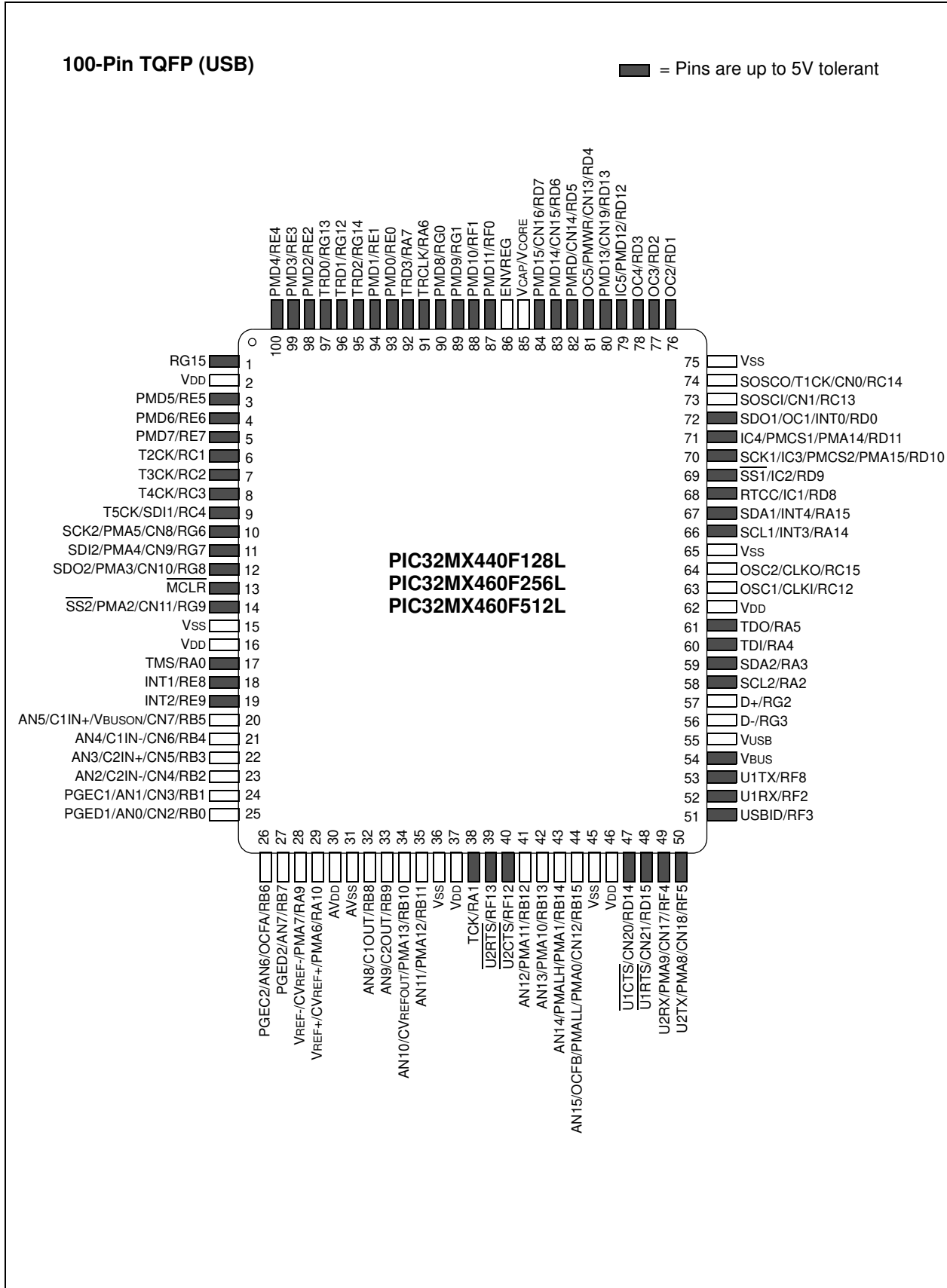

Pin Diagrams (Continued)

121-Pin XBGA⁽¹⁾

● = Pins are up to 5V tolerant

PIC32MX440F128L
 PIC32MX460F256L
 PIC32MX460F512L

| | 1 | 2 | 3 | 4 | 5 | 6 | 7 | 8 | 9 | 10 | 11 |
|---|-----------|----------------------|-----------------------|-----------------------|----------------------|----------------------|--|-----------------------|-----------------------|-----------|-----------|
| A | ● RE4 | ● RE3 | ● RG13 | ● RE0 | ● RG0 | ● RF1 | ○ ENVREG | ○ Vss | ● RD12 | ● RD2 | ● RD1 |
| B | ● NC | ● RG15 | ● RE2 | ● RE1 | ● RA7 | ● RF0 | ○ V _{CORE} / V _{CAP} | ● RD5 | ● RD3 | ○ Vss | ○ RC14 |
| C | ● RE6 | ○ V _{DD} | ● RG12 | ● RG14 | ● RA6 | ● NC | ● RD7 | ● RD4 | ○ V _{DD} | ○ RC13 | ● RD11 |
| D | ● RC1 | ● RE7 | ● RE5 | ○ Vss | ○ Vss | ● NC | ● RD6 | ● RD13 | ● RD0 | ● NC | ● RD10 |
| E | ● RC4 | ● RC3 | ● RG6 | ● RC2 | ○ V _{DD} | ● RG1 | ○ Vss | ● RA15 | ● RD8 | ● RD9 | ● RA14 |
| F | ● MCLR | ● RG8 | ● RG9 | ● RG7 | ○ Vss | ● NC | ● NC | ○ V _{DD} | ○ RC12 | ○ Vss | ○ RC15 |
| G | ● RE8 | ● RE9 | ● RA0 | ● NC | ○ V _{DD} | ○ Vss | ○ Vss | ● NC | ● RA5 | ● RA3 | ● RA4 |
| H | ○ RB5 | ○ RB4 | ○ Vss | ○ V _{DD} | ● NC | ○ V _{DD} | ● NC | ● V _{BUS} | ○ V _{USB} | ● RG2 | ● RA2 |
| J | ○ RB3 | ○ RB2 | ○ RB7 | ○ AV _{DD} | ○ RB11 | ○ RA1 | ○ RB12 | ● NC | ● NC | ● RF8 | ○ RG3 |
| K | ○ RB1 | ○ RB0 | ○ RA10 | ○ RB8 | ● NC | ● RF12 | ○ RB14 | ○ V _{DD} | ● RD15 | ● RF3 | ● RF2 |
| L | ○ RB6 | ○ RA9 | ○ AV _{SS} | ○ RB9 | ○ RB10 | ● RF13 | ○ RB13 | ○ RB15 | ● RD14 | ● RF4 | ● RF5 |

Note 1: Refer to [Table 4](#) for full pin names.

PIC32MX3XX/4XX

TABLE 4: PIN NAMES: PIC32MX440F128L, PIC32MX460F256L AND PIC32MX460F512L DEVICES

| Pin Number | Full Pin Name |
|------------|---------------------------|
| A1 | PMD4/RE4 |
| A2 | PMD3/RE3 |
| A3 | TRD0/RG13 |
| A4 | PMD0/RE0 |
| A5 | PMD8/RG0 |
| A6 | PMD10/RF1 |
| A7 | ENVREG |
| A8 | Vss |
| A9 | IC5/PMD12/RD12 |
| A10 | OC3/RD2 |
| A11 | OC2/RD1 |
| B1 | No Connect (NC) |
| B2 | RG15 |
| B3 | PMD2/RE2 |
| B4 | PMD1/RE1 |
| B5 | TRD3/RA7 |
| B6 | PMD11/RF0 |
| B7 | VCAP/VCORE |
| B8 | PMRD/CN14/RD5 |
| B9 | OC4/RD3 |
| B10 | Vss |
| B11 | SOSCO/T1CK/CN0/RC14 |
| C1 | PMD6/RE6 |
| C2 | VDD |
| C3 | TRD1/RG12 |
| C4 | TRD2/RG14 |
| C5 | TRCLK/RA6 |
| C6 | No Connect (NC) |
| C7 | PMD15/CN16/RD7 |
| C8 | OC5/PMWR/CN13/RD4 |
| C9 | VDD |
| C10 | SOSCI/CN1/RC13 |
| C11 | IC4/PMCS1/PMA14/RD11 |
| D1 | T2CK/RC1 |
| D2 | PMD7/RE7 |
| D3 | PMD5/RE5 |
| D4 | Vss |
| D5 | Vss |
| D6 | No Connect (NC) |
| D7 | PMD14/CN15/RD6 |
| D8 | CN19/PMD13/RD13 |
| D9 | SDO1/OC1/INT0/RD0 |
| D10 | No Connect (NC) |
| D11 | SCK1/IC3/PMCS2/PMA15/RD10 |
| E1 | T5CK/SDI1/RC4 |
| E2 | T4CK/RC3 |
| E3 | SCK2/PMA5/CN8/RG6 |
| E4 | T3CK/RC2 |
| E5 | VDD |
| E6 | PMD9/RG1 |
| E7 | Vss |

| Pin Number | Full Pin Name |
|------------|--------------------------|
| E8 | SDA1/INT4/RA15 |
| E9 | RTCC/IC1/RD8 |
| E10 | SS1/IC2/RD9 |
| E11 | SCL1/INT3/RA14 |
| F1 | MCLR |
| F2 | SDO2/PMA3/CN10/RG8 |
| F3 | SS2/PMA2/CN11/RG9 |
| F4 | SDI2/PMA4/CN9/RG7 |
| F5 | Vss |
| F6 | No Connect (NC) |
| F7 | No Connect (NC) |
| F8 | VDD |
| F9 | OSC1/CLKI/RC12 |
| F10 | Vss |
| F11 | OSC2/CLKO/RC15 |
| G1 | INT1/RE8 |
| G2 | INT2/RE9 |
| G3 | TMS/RA0 |
| G4 | No Connect (NC) |
| G5 | VDD |
| G6 | Vss |
| G7 | Vss |
| G8 | No Connect (NC) |
| G9 | TDO/RA5 |
| G10 | SDA2/RA3 |
| G11 | TDI/RA4 |
| H1 | AN5/C1IN+/VBUSON/CN7/RB5 |
| H2 | AN4/C1IN-/CN6/RB4 |
| H3 | Vss |
| H4 | VDD |
| H5 | No Connect (NC) |
| H6 | VDD |
| H7 | No Connect (NC) |
| H8 | VBUS |
| H9 | VUSB |
| H10 | D+/RG2 |
| H11 | SCL2/RA2 |
| J1 | AN3/C2IN+/CN5/RB3 |
| J2 | AN2/C2IN-/CN4/RB2 |
| J3 | PGED2/AN7/RB7 |
| J4 | AVDD |
| J5 | AN11/PMA12/RB11 |
| J6 | TCK/RA1 |
| J7 | AN12/PMA11/RB12 |
| J8 | No Connect (NC) |
| J9 | No Connect (NC) |
| J10 | U1TX/RF8 |
| J11 | D-/RG3 |
| K1 | PGEC1/AN1/CN3/RB1 |
| K2 | PGED1/AN0/CN2/RB0 |
| K3 | VREF+/CVREF+/PMA6/RA10 |

TABLE 4: PIN NAMES: PIC32MX440F128L, PIC32MX460F256L AND PIC32MX460F512L DEVICES (CONTINUED)

| Pin Number | Full Pin Name |
|------------|-------------------------------|
| K4 | AN8/C1OUT/RB8 |
| K5 | No Connect (NC) |
| K6 | $\overline{U2CTS}$ /RF12 |
| K7 | AN14/PMALH/PMA1/RB14 |
| K8 | VDD |
| K9 | $\overline{U1RTS}$ /CN21/RD15 |
| K10 | USBID/RF3 |
| K11 | U1RX/RF2 |
| L1 | PGEC2/AN6/OCFA/RB6 |
| L2 | VREF-/CVREF-/PMA7/RA9 |

| Pin Number | Full Pin Name |
|------------|--------------------------------|
| L3 | AVSS |
| L4 | AN9/C2OUT/RB9 |
| L5 | AN10/CVREFOUT/PMA13/RB10 |
| L6 | $\overline{U2RTS}$ /RF13 |
| L7 | AN13/PMA10/RB13 |
| L8 | AN15/OCFB/PMALL/PMA0/CN12/RB15 |
| L9 | $\overline{U1CTS}$ /CN20/RD14 |
| L10 | U2RX/PMA9/CN17/RF4 |
| L11 | U2TX/PMA8/CN18/RF5 |

PIC32MX3XX/4XX

Table of Contents

| | | |
|------|---|-----|
| 1.0 | Device Overview | 21 |
| 2.0 | Guidelines for Getting Started with 32-bit Microcontrollers | 31 |
| 3.0 | CPU | 37 |
| 4.0 | Memory Organization | 43 |
| 5.0 | Flash Program Memory | 85 |
| 6.0 | Resets | 87 |
| 7.0 | Interrupt Controller | 89 |
| 8.0 | Oscillator Configuration | 93 |
| 9.0 | Prefetch Cache | 95 |
| 10.0 | Direct Memory Access (DMA) Controller | 97 |
| 11.0 | USB On-The-Go (OTG) | 99 |
| 12.0 | I/O Ports | 101 |
| 13.0 | Timer1 | 103 |
| 14.0 | Timer2/3 and Timer4/5 | 105 |
| 15.0 | Input Capture | 107 |
| 16.0 | Output Compare | 109 |
| 17.0 | Serial Peripheral Interface (SPI) | 111 |
| 18.0 | Inter-Integrated Circuit™ (I ² C™) | 113 |
| 19.0 | Universal Asynchronous Receiver Transmitter (UART) | 115 |
| 20.0 | Parallel Master Port (PMP) | 119 |
| 21.0 | Real-Time Clock and Calendar (RTCC) | 121 |
| 22.0 | 10-bit Analog-to-Digital Converter (ADC) | 123 |
| 23.0 | Comparator | 125 |
| 24.0 | Comparator Voltage Reference (CVREF) | 127 |
| 25.0 | Power-Saving Features | 129 |
| 26.0 | Special Features | 131 |
| 27.0 | Instruction Set | 141 |
| 28.0 | Development Support | 147 |
| 29.0 | Electrical Characteristics | 151 |
| 30.0 | Packaging Information | 191 |
| | Index | 209 |

TO OUR VALUED CUSTOMERS

It is our intention to provide our valued customers with the best documentation possible to ensure successful use of your Microchip products. To this end, we will continue to improve our publications to better suit your needs. Our publications will be refined and enhanced as new volumes and updates are introduced.

If you have any questions or comments regarding this publication, please contact the Marketing Communications Department via E-mail at docerrors@microchip.com or fax the **Reader Response Form** in the back of this data sheet to (480) 792-4150. We welcome your feedback.

Most Current Data Sheet

To obtain the most up-to-date version of this data sheet, please register at our Worldwide Web site at:

<http://www.microchip.com>

You can determine the version of a data sheet by examining its literature number found on the bottom outside corner of any page. The last character of the literature number is the version number, (e.g., DS30000A is version A of document DS30000).

Errata

An errata sheet, describing minor operational differences from the data sheet and recommended workarounds, may exist for current devices. As device/documentation issues become known to us, we will publish an errata sheet. The errata will specify the revision of silicon and revision of document to which it applies.

To determine if an errata sheet exists for a particular device, please check with one of the following:

- Microchip's Worldwide Web site; <http://www.microchip.com>
- Your local Microchip sales office (see last page)

When contacting a sales office, please specify which device, revision of silicon and data sheet (include literature number) you are using.

Customer Notification System

Register on our web site at www.microchip.com to receive the most current information on all of our products.

PIC32MX3XX/4XX

NOTES:

1.0 DEVICE OVERVIEW

Note 1: This data sheet summarizes the features of the PIC32MX3XX/4XX family of devices. It is not intended to be a comprehensive reference source. To complement the information in this data sheet, refer to the “PIC32 Family Reference Manual”, which is available from the Microchip web site (www.microchip.com/PIC32).

2: Some registers and associated bits described in this section may not be available on all devices. Refer to **Section 4.0 “Memory Organization”** in this data sheet for device-specific register and bit information.

This document contains device-specific information for the PIC32MX3XX/4XX devices.

Figure 1-1 illustrates a general block diagram of the core and peripheral modules in the PIC32MX3XX/4XX family of devices.

Table 1-1 lists the functions of the various pins shown in the pinout diagrams.

FIGURE 1-1: BLOCK DIAGRAM^(1,2)

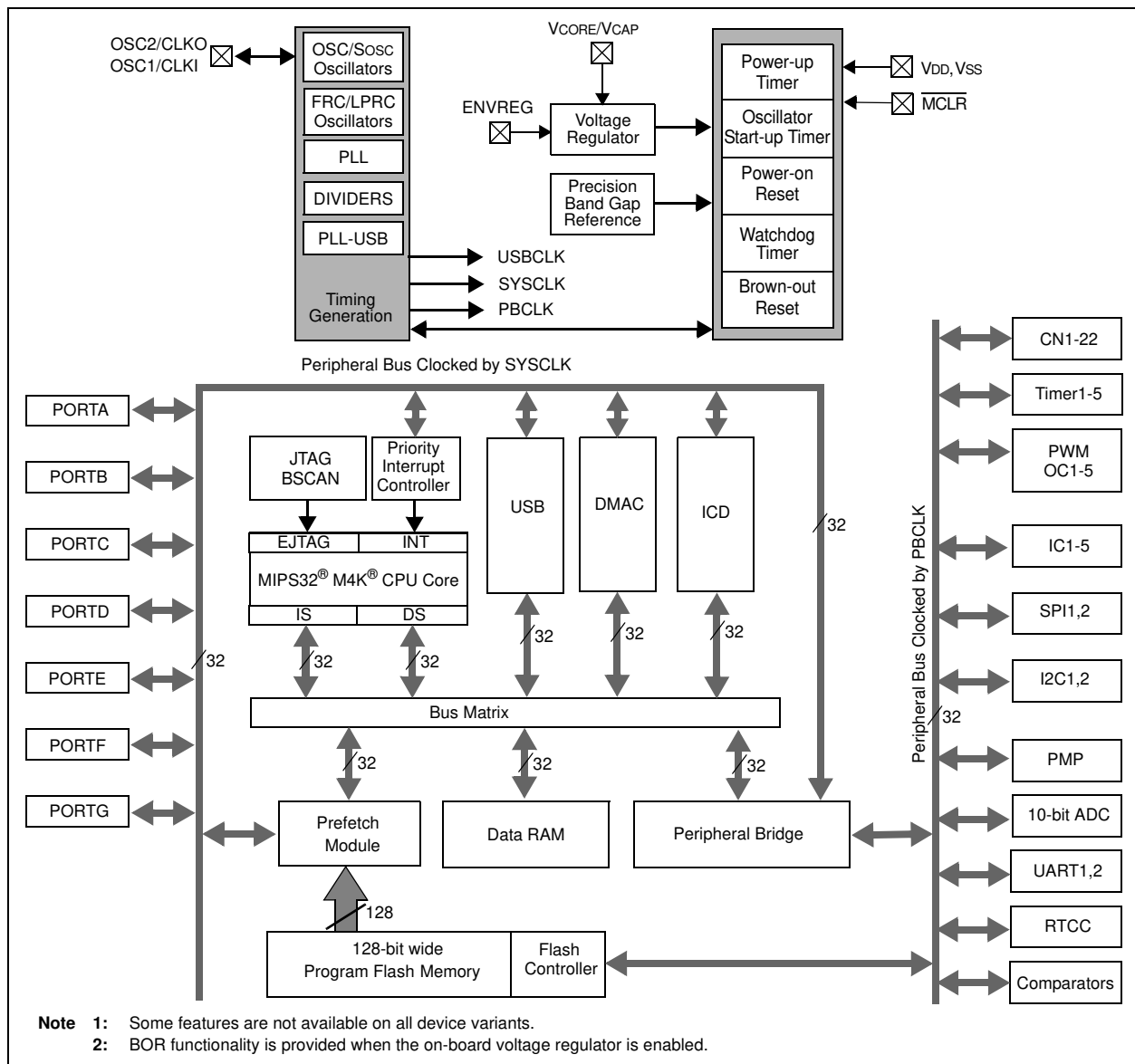

PIC32MX3XX/4XX

TABLE 1-1: PINOUT I/O DESCRIPTIONS

| Pin Name | Pin Number ⁽¹⁾ | | | Pin Type | Buffer Type | Description |
|----------|---------------------------|--------------|--------------|----------|-------------|--|
| | 64-pin QFN/TQFP | 100-pin TQFP | 121-pin XBGA | | | |
| AN0 | 16 | 25 | K2 | I | Analog | Analog input channels. |
| AN1 | 15 | 24 | K1 | I | Analog | |
| AN2 | 14 | 23 | J2 | I | Analog | |
| AN3 | 13 | 22 | J1 | I | Analog | |
| AN4 | 12 | 21 | H2 | I | Analog | |
| AN5 | 11 | 20 | H1 | I | Analog | |
| AN6 | 17 | 26 | L1 | I | Analog | |
| AN7 | 18 | 27 | J3 | I | Analog | |
| AN8 | 21 | 32 | K4 | I | Analog | |
| AN9 | 22 | 33 | L4 | I | Analog | |
| AN10 | 23 | 34 | L5 | I | Analog | |
| AN11 | 24 | 35 | J5 | I | Analog | |
| AN12 | 27 | 41 | J7 | I | Analog | |
| AN13 | 28 | 42 | L7 | I | Analog | |
| AN14 | 29 | 43 | K7 | I | Analog | |
| AN15 | 30 | 44 | L8 | I | Analog | |
| CLKI | 39 | 63 | F9 | I | ST/CMOS | External clock source input. Always associated with OSC1 pin function. |
| CLKO | 40 | 64 | F11 | O | — | Oscillator crystal output. Connects to crystal or resonator in Crystal Oscillator mode. Optionally functions as CLKO in RC and EC modes. Always associated with OSC2 pin function. |
| OSC1 | 39 | 63 | F9 | I | ST/CMOS | Oscillator crystal input. ST buffer when configured in RC mode; CMOS otherwise. |
| OSC2 | 40 | 64 | F11 | I/O | — | Oscillator crystal output. Connects to crystal or resonator in Crystal Oscillator mode. Optionally functions as CLKO in RC and EC modes. |
| SOSCI | 47 | 73 | C10 | I | ST/CMOS | 32.768 kHz low-power oscillator crystal input; CMOS otherwise. |
| SOSCO | 48 | 74 | B11 | O | — | 32.768 kHz low-power oscillator crystal output. |

Legend: CMOS = CMOS compatible input or output Analog = Analog input P = Power
 ST = Schmitt Trigger input with CMOS levels O = Output I = Input
 TTL = TTL input buffer

Note 1: Pin numbers are provided for reference only. See the “[Pin Diagrams](#)” section for device pin availability.

TABLE 1-1: PINOUT I/O DESCRIPTIONS (CONTINUED)

| Pin Name | Pin Number ⁽¹⁾ | | | Pin Type | Buffer Type | Description |
|----------|---------------------------|--------------|--------------|----------|-------------|---|
| | 64-pin QFN/TQFP | 100-pin TQFP | 121-pin XBGA | | | |
| CN0 | 48 | 74 | B11 | I | ST | Change notification inputs. Can be software programmed for internal weak pull-ups on all inputs. |
| CN1 | 47 | 73 | C10 | I | ST | |
| CN2 | 16 | 25 | K2 | I | ST | |
| CN3 | 15 | 24 | K1 | I | ST | |
| CN4 | 14 | 23 | J2 | I | ST | |
| CN5 | 13 | 22 | J1 | I | ST | |
| CN6 | 12 | 21 | H2 | I | ST | |
| CN7 | 11 | 20 | H1 | I | ST | |
| CN8 | 4 | 10 | E3 | I | ST | |
| CN9 | 5 | 11 | F4 | I | ST | |
| CN10 | 6 | 12 | F2 | I | ST | |
| CN11 | 8 | 14 | F3 | I | ST | |
| CN12 | 30 | 44 | L8 | I | ST | |
| CN13 | 52 | 81 | C8 | I | ST | |
| CN14 | 53 | 82 | B8 | I | ST | |
| CN15 | 54 | 83 | D7 | I | ST | |
| CN16 | 55 | 84 | C7 | I | ST | |
| CN17 | 31 | 49 | L10 | I | ST | |
| CN18 | 32 | 50 | L11 | I | ST | |
| CN19 | — | 80 | D8 | I | ST | |
| CN20 | — | 47 | L9 | I | ST | |
| CN21 | — | 48 | K9 | I | ST | |
| IC1 | 42 | 68 | E9 | I | ST | Capture inputs 1-5. |
| IC2 | 43 | 69 | E10 | I | ST | |
| IC3 | 44 | 70 | D11 | I | ST | |
| IC4 | 45 | 71 | C11 | I | ST | |
| IC5 | 52 | 79 | A9 | I | ST | |
| OCFA | 17 | 26 | L1 | I | ST | Output Compare Fault A Input. |
| OC1 | 46 | 72 | D9 | O | — | Output Compare output 1. |
| OC2 | 49 | 76 | A11 | O | — | Output Compare output 2 |
| OC3 | 50 | 77 | A10 | O | — | Output Compare output 3. |
| OC4 | 51 | 78 | B9 | O | — | Output Compare output 4. |
| OC5 | 52 | 81 | C8 | O | — | Output Compare output 5. |
| OCFB | 30 | 44 | L8 | I | ST | Output Compare Fault B Input. |
| INT0 | 35,46 | 55,72 | H9,D9 | I | ST | External interrupt 0. |
| INT1 | 42 | 18 | 61 | I | ST | External interrupt 1. |
| INT2 | 43 | 19 | 62 | I | ST | External interrupt 2. |

Legend: CMOS = CMOS compatible input or output Analog = Analog input P = Power
 ST = Schmitt Trigger input with CMOS levels O = Output I = Input
 TTL = TTL input buffer

Note 1: Pin numbers are provided for reference only. See the “[Pin Diagrams](#)” section for device pin availability.

PIC32MX3XX/4XX

TABLE 1-1: PINOUT I/O DESCRIPTIONS (CONTINUED)

| Pin Name | Pin Number ⁽¹⁾ | | | Pin Type | Buffer Type | Description | |
|----------|---------------------------|--------------|--------------|----------|-------------|------------------------------------|------------------------------------|
| | 64-pin QFN/TQFP | 100-pin TQFP | 121-pin XBGA | | | | |
| INT3 | 44 | 66 | E11 | I | ST | External interrupt 3. | |
| INT4 | 45 | 67 | E8 | I | ST | External interrupt 4. | |
| RA0 | — | 17 | G3 | I/O | ST | PORTA is a bidirectional I/O port. | |
| RA1 | — | 38 | J6 | I/O | ST | | |
| RA2 | — | 58 | H11 | I/O | ST | | |
| RA3 | — | 59 | G10 | I/O | ST | | |
| RA4 | — | 60 | G11 | I/O | ST | | |
| RA5 | — | 61 | G9 | I/O | ST | | |
| RA6 | — | 91 | C5 | I/O | ST | | |
| RA7 | — | 92 | B5 | I/O | ST | | |
| RA9 | — | 28 | L2 | I/O | ST | | |
| RA10 | — | 29 | K3 | I/O | ST | | |
| RA14 | — | 66 | E11 | I/O | ST | | |
| RA15 | — | 67 | E8 | I/O | ST | | |
| RB0 | 16 | 25 | K2 | I/O | ST | | PORTB is a bidirectional I/O port. |
| RB1 | 15 | 24 | K1 | I/O | ST | | |
| RB2 | 14 | 23 | J2 | I/O | ST | | |
| RB3 | 13 | 22 | J1 | I/O | ST | | |
| RB4 | 12 | 21 | H2 | I/O | ST | | |
| RB5 | 11 | 20 | H1 | I/O | ST | | |
| RB6 | 17 | 26 | L1 | I/O | ST | | |
| RB7 | 18 | 27 | J3 | I/O | ST | | |
| RB8 | 21 | 32 | K4 | I/O | ST | | |
| RB9 | 22 | 33 | L4 | I/O | ST | | |
| RB10 | 23 | 34 | L5 | I/O | ST | | |
| RB11 | 24 | 35 | J5 | I/O | ST | | |
| RB12 | 27 | 41 | J7 | I/O | ST | | |
| RB13 | 28 | 42 | L7 | I/O | ST | | |
| RB14 | 29 | 43 | K7 | I/O | ST | | |
| RB15 | 30 | 44 | L8 | I/O | ST | | |
| RC1 | — | 6 | D1 | I/O | ST | PORTC is a bidirectional I/O port. | |
| RC2 | — | 7 | E4 | I/O | ST | | |
| RC3 | — | 8 | E2 | I/O | ST | | |
| RC4 | — | 9 | E1 | I/O | ST | | |
| RC12 | 39 | 63 | F9 | I/O | ST | | |
| RC13 | 47 | 73 | C10 | I/O | ST | | |
| RC14 | 48 | 74 | B11 | I/O | ST | | |
| RC15 | 40 | 64 | F11 | I/O | ST | | |

Legend: CMOS = CMOS compatible input or output Analog = Analog input P = Power
 ST = Schmitt Trigger input with CMOS levels O = Output I = Input
 TTL = TTL input buffer

Note 1: Pin numbers are provided for reference only. See the “[Pin Diagrams](#)” section for device pin availability.

TABLE 1-1: PINOUT I/O DESCRIPTIONS (CONTINUED)

| Pin Name | Pin Number ⁽¹⁾ | | | Pin Type | Buffer Type | Description |
|----------|---------------------------|--------------|--------------|----------|-------------|------------------------------------|
| | 64-pin QFN/TQFP | 100-pin TQFP | 121-pin XBGA | | | |
| RD0 | 46 | 72 | D9 | I/O | ST | PORTD is a bidirectional I/O port. |
| RD1 | 49 | 76 | A11 | I/O | ST | |
| RD2 | 50 | 77 | A10 | I/O | ST | |
| RD3 | 51 | 78 | B9 | I/O | ST | |
| RD4 | 52 | 81 | C8 | I/O | ST | |
| RD5 | 53 | 82 | B8 | I/O | ST | |
| RD6 | 54 | 83 | D7 | I/O | ST | |
| RD7 | 55 | 84 | C7 | I/O | ST | |
| RD8 | 42 | 68 | E9 | I/O | ST | |
| RD9 | 43 | 69 | E10 | I/O | ST | |
| RD10 | 44 | 70 | D11 | I/O | ST | |
| RD11 | 45 | 71 | C11 | I/O | ST | |
| RD12 | — | 79 | A9 | I/O | ST | |
| RD13 | — | 80 | D8 | I/O | ST | |
| RD14 | — | 47 | L9 | I/O | ST | |
| RD15 | — | 48 | K9 | I/O | ST | |
| RE0 | 60 | 93 | A4 | I/O | ST | PORTE is a bidirectional I/O port. |
| RE1 | 61 | 94 | B4 | I/O | ST | |
| RE2 | 62 | 98 | B3 | I/O | ST | |
| RE3 | 63 | 99 | A2 | I/O | ST | |
| RE4 | 64 | 100 | A1 | I/O | ST | |
| RE5 | 1 | 3 | D3 | I/O | ST | |
| RE6 | 2 | 4 | C1 | I/O | ST | |
| RE7 | 3 | 5 | D2 | I/O | ST | |
| RE8 | — | 18 | G1 | I/O | ST | |
| RE9 | — | 19 | G2 | I/O | ST | |
| RF0 | 58 | 87 | B6 | I/O | ST | PORTF is a bidirectional I/O port. |
| RF1 | 59 | 88 | A6 | I/O | ST | |
| RF2 | 34 | 52 | K11 | I/O | ST | |
| RF3 | 33 | 51 | K10 | I/O | ST | |
| RF4 | 31 | 49 | L10 | I/O | ST | |
| RF5 | 32 | 50 | L11 | I/O | ST | |
| RF6 | 35 | 55 | H9 | I/O | ST | |
| RF7 | — | 54 | H8 | I/O | ST | |
| RF8 | — | 53 | J10 | I/O | ST | |
| RF12 | — | 40 | K6 | I/O | ST | |
| RF13 | — | 39 | L6 | I/O | ST | |

Legend: CMOS = CMOS compatible input or output Analog = Analog input P = Power
 ST = Schmitt Trigger input with CMOS levels O = Output I = Input
 TTL = TTL input buffer

Note 1: Pin numbers are provided for reference only. See the “Pin Diagrams” section for device pin availability.

PIC32MX3XX/4XX

TABLE 1-1: PINOUT I/O DESCRIPTIONS (CONTINUED)

| Pin Name | Pin Number ⁽¹⁾ | | | Pin Type | Buffer Type | Description |
|--------------------|---------------------------|--------------|--------------|----------|-------------|---|
| | 64-pin QFN/TQFP | 100-pin TQFP | 121-pin XBGA | | | |
| RG0 | — | 90 | A5 | I/O | ST | PORTG is a bidirectional I/O port. |
| RG1 | — | 89 | E6 | I/O | ST | |
| RG6 | 4 | 10 | E3 | I/O | ST | |
| RG7 | 5 | 11 | F4 | I/O | ST | |
| RG8 | 6 | 12 | F2 | I/O | ST | |
| RG9 | 8 | 14 | F3 | I/O | ST | |
| RG12 | — | 96 | C3 | I/O | ST | |
| RG13 | — | 97 | A3 | I/O | ST | |
| RG14 | — | 95 | C4 | I/O | ST | |
| RG15 | — | 1 | B2 | I/O | ST | |
| RG2 | 37 | 57 | H10 | I | ST | PORTG input pins. |
| RG3 | 36 | 56 | J11 | I | ST | |
| T1CK | 48 | 74 | B11 | I | ST | Timer1 external clock input. |
| T2CK | — | 6 | D1 | I | ST | Timer2 external clock input. |
| T3CK | — | 7 | E4 | I | ST | Timer3 external clock input. |
| T4CK | — | 8 | E2 | I | ST | Timer4 external clock input. |
| T5CK | — | 9 | E1 | I | ST | Timer5 external clock input. |
| $\overline{U1CTS}$ | 43 | 47 | L9 | I | ST | UART1 clear to send. |
| $\overline{U1RTS}$ | 35, 49 | 48 | K9 | O | — | UART1 ready to send. |
| U1RX | 34, 50 | 52 | K11 | I | ST | UART1 receive. |
| U1TX | 33, 51 | 51, 53 | J10, K10 | O | — | UART1 transmit. |
| $\overline{U2CTS}$ | 21 | 40 | K6 | I | ST | UART2 clear to send. |
| $\overline{U2RTS}$ | 29 | 39 | L6 | O | — | UART2 ready to send. |
| U2RX | 31 | 49 | L10 | I | ST | UART2 receive. |
| U2TX | 32 | 50 | L11 | O | — | UART2 transmit. |
| SCK1 | 35 | 55, 70 | D11, H9 | I/O | ST | Synchronous serial clock input/output for SPI1. |
| SDI1 | 34 | 9, 54 | E1, H8 | I | ST | SPI1 data in. |
| SDO1 | 33 | 53, 72 | D9, J10 | O | — | SPI1 data out. |
| $\overline{SS1}$ | 14 | 23, 69 | E10, J2 | I/O | ST | SPI1 slave synchronization or frame pulse I/O. |
| SCK2 | 4 | 10 | E3 | I/O | ST | Synchronous serial clock input/output for SPI2. |
| SDI2 | 5 | 11 | F4 | I | ST | SPI2 data in. |
| SDO2 | 6 | 12 | F2 | O | — | SPI2 data out. |
| $\overline{SS2}$ | 8 | 14 | F3 | I/O | ST | SPI2 slave synchronization or frame pulse I/O. |
| SCL1 | 37, 44 | 57, 66 | E11, H10 | I/O | ST | Synchronous serial clock input/output for I2C1. |
| SDA1 | 36, 43 | 56, 67 | E8, J11 | I/O | ST | Synchronous serial data input/output for I2C1. |
| SCL2 | 32 | 58 | H11 | I/O | ST | Synchronous serial clock input/output for I2C2. |
| SDA2 | 31 | 59 | G10 | I/O | ST | Synchronous serial data input/output for I2C2. |

Legend: CMOS = CMOS compatible input or output Analog = Analog input P = Power
 ST = Schmitt Trigger input with CMOS levels O = Output I = Input
 TTL = TTL input buffer

Note 1: Pin numbers are provided for reference only. See the “[Pin Diagrams](#)” section for device pin availability.

TABLE 1-1: PINOUT I/O DESCRIPTIONS (CONTINUED)

| Pin Name | Pin Number ⁽¹⁾ | | | Pin Type | Buffer Type | Description |
|----------|---------------------------|--------------|--------------|----------|-------------|--|
| | 64-pin QFN/TQFP | 100-pin TQFP | 121-pin XBGA | | | |
| TMS | 23 | 17 | G3 | I | ST | JTAG Test mode select pin. |
| TCK | 27 | 38 | J6 | I | ST | JTAG test clock input pin. |
| TDI | 28 | 60 | G11 | I | ST | JTAG test data input pin. |
| TDO | 24 | 61 | G9 | O | — | JTAG test data output pin. |
| RTCC | 42 | 68 | E9 | O | — | Real-Time Clock Alarm Output. |
| CVREF- | 15 | 28 | L2 | I | Analog | Comparator Voltage Reference (low). |
| CVREF+ | 16 | 29 | K3 | I | Analog | Comparator Voltage Reference (high). |
| CVREFOUT | 23 | 34 | L5 | O | Analog | Comparator Voltage Reference Output. |
| C1IN- | 12 | 21 | H2 | I | Analog | Comparator 1 Negative Input. |
| C1IN+ | 11 | 20 | H1 | I | Analog | Comparator 1 Positive Input. |
| C1OUT | 21 | 32 | K4 | O | — | Comparator 1 Output. |
| C2IN- | 14 | 23 | J2 | I | Analog | Comparator 2 Negative Input. |
| C2IN+ | 13 | 22 | J1 | I | Analog | Comparator 2 Positive Input. |
| C2OUT | 22 | 33 | L4 | O | — | Comparator 2 Output. |
| PMA0 | 30 | 44 | L8 | I/O | TTL/ST | Parallel Master Port Address Bit 0 Input (Buffered Slave modes) and Output (Master modes). |
| PMA1 | 29 | 43 | K7 | I/O | TTL/ST | Parallel Master Port Address Bit 1 Input (Buffered Slave modes) and Output (Master modes). |
| PMA2 | 8 | 14 | F3 | O | — | Parallel Master Port Address (De-multiplexed Master Modes). |
| PMA3 | 6 | 12 | F2 | O | — | |
| PMA4 | 5 | 11 | F4 | O | — | |
| PMA5 | 4 | 10 | E3 | O | — | |
| PMA6 | 16 | 29 | K3 | O | — | |
| PMA7 | 22 | 28 | L2 | O | — | |
| PMA8 | 32 | 50 | L11 | O | — | |
| PMA9 | 31 | 49 | L10 | O | — | |
| PMA10 | 28 | 42 | L7 | O | — | |
| PMA11 | 27 | 41 | J7 | O | — | |
| PMA12 | 24 | 35 | J5 | O | — | |
| PMA13 | 23 | 34 | L5 | O | — | |
| PMA14 | 45 | 71 | C11 | O | — | |
| PMA15 | 44 | 70 | D11 | O | — | |
| PMCS1 | 45 | 71 | C11 | O | — | |
| PMCS2 | 44 | 70 | D11 | O | — | Parallel Master Port Chip Select 2 Strobe. |

Legend: CMOS = CMOS compatible input or output Analog = Analog input P = Power
 ST = Schmitt Trigger input with CMOS levels O = Output I = Input
 TTL = TTL input buffer

Note 1: Pin numbers are provided for reference only. See the “[Pin Diagrams](#)” section for device pin availability.

PIC32MX3XX/4XX

TABLE 1-1: PINOUT I/O DESCRIPTIONS (CONTINUED)

| Pin Name | Pin Number ⁽¹⁾ | | | Pin Type | Buffer Type | Description |
|----------|---------------------------|--------------|--------------|----------|-------------|---|
| | 64-pin QFN/TQFP | 100-pin TQFP | 121-pin XBGA | | | |
| PMD0 | 60 | 93 | A4 | I/O | TTL/ST | Parallel Master Port Data (De-multiplexed Master mode) or Address/Data (Multiplexed Master modes). |
| PMD1 | 61 | 94 | B4 | I/O | TTL/ST | |
| PMD2 | 62 | 98 | B3 | I/O | TTL/ST | |
| PMD3 | 63 | 99 | A2 | I/O | TTL/ST | |
| PMD4 | 64 | 100 | A1 | I/O | TTL/ST | |
| PMD5 | 1 | 3 | D3 | I/O | TTL/ST | |
| PMD6 | 2 | 4 | C1 | I/O | TTL/ST | |
| PMD7 | 3 | 5 | D2 | I/O | TTL/ST | |
| PMD8 | — | 90 | A5 | I/O | TTL/ST | |
| PMD9 | — | 89 | E6 | I/O | TTL/ST | |
| PMD10 | — | 88 | A6 | I/O | TTL/ST | |
| PMD11 | — | 87 | B6 | I/O | TTL/ST | |
| PMD12 | — | 79 | A9 | I/O | TTL/ST | |
| PMD13 | — | 80 | D8 | I/O | TTL/ST | |
| PMD14 | — | 83 | D7 | I/O | TTL/ST | |
| PMD15 | — | 84 | C7 | I/O | TTL/ST | |
| PMRD | 53 | 82 | B8 | O | — | Parallel Master Port Read Strobe. |
| PMWR | 52 | 81 | C8 | O | — | Parallel Master Port Write Strobe. |
| PMALL | 30 | 44 | L8 | O | — | Parallel Master Port Address Latch Enable low-byte (Multiplexed Master modes). |
| PMALH | 29 | 43 | K7 | O | — | Parallel Master Port Address Latch Enable high-byte (Multiplexed Master modes). |
| VBUS | 34 | 54 | H8 | I | Analog | USB Bus Power Monitor. |
| VUSB | 35 | 55 | H9 | P | — | USB Internal Transceiver Supply. If the USB module is <i>not</i> used, this pin must be connected to VDD. |
| VBUSON | 11 | 20 | H1 | O | — | USB Host and OTG Bus Power Control Output. |
| D+ | 37 | 57 | H10 | I/O | Analog | USB D+. |
| D- | 36 | 56 | J11 | I/O | Analog | USB D-. |
| USBID | 33 | 51 | K10 | I | ST | USB OTG ID Detect. |
| ENVREG | 57 | 86 | A7 | I | ST | Enable for On-Chip Voltage Regulator. |
| TRCLK | — | 91 | C5 | O | — | Trace Clock. |
| TRD0 | — | 97 | A3 | O | — | Trace Data Bits 0-3. |
| TRD1 | — | 96 | C3 | O | — | |
| TRD2 | — | 95 | C4 | O | — | |
| TRD3 | — | 92 | B5 | O | — | |
| PGED1 | 16 | 25 | K2 | I/O | ST | Data I/O pin for programming/debugging communication channel 1. |
| PGEC1 | 15 | 24 | K1 | I | ST | Clock input pin for programming/debugging communication channel 1. |

Legend: CMOS = CMOS compatible input or output Analog = Analog input P = Power
 ST = Schmitt Trigger input with CMOS levels O = Output I = Input
 TTL = TTL input buffer

Note 1: Pin numbers are provided for reference only. See the “[Pin Diagrams](#)” section for device pin availability.

TABLE 1-1: PINOUT I/O DESCRIPTIONS (CONTINUED)

| Pin Name | Pin Number ⁽¹⁾ | | | Pin Type | Buffer Type | Description |
|---|---------------------------|--------------------|--|----------|-------------|--|
| | 64-pin QFN/TQFP | 100-pin TQFP | 121-pin XBGA | | | |
| PGED2 | 18 | 27 | J3 | I/O | ST | Data I/O pin for programming/debugging communication channel 2. |
| PGEC2 | 17 | 26 | L1 | I | ST | Clock input pin for programming/debugging communication channel 2. |
| $\overline{\text{MCLR}}$ | 7 | 13 | F1 | I/P | ST | Master Clear (Reset) input. This pin is an active-low Reset to the device. |
| AVDD | 19 | 30 | J4 | P | P | Positive supply for analog modules. This pin must be connected at all times. |
| AVSS | 20 | 31 | L3 | P | P | Ground reference for analog modules. |
| VDD | 10, 26, 38 | 2, 16, 37, 46, 62 | C2, C9, E5, F8, G5, H4, H6, K8 | P | — | Positive supply for peripheral logic and I/O pins. |
| V _{CORE} / V _{CAP} | 56 | 85 | B7 | P | — | Capacitor for Internal Voltage Regulator. |
| V _{SS} | 9, 25, 41 | 15, 36, 45, 65, 75 | A8, B10, D4, D5, E7, F10, F5, G6, G7, H3 | P | — | Ground reference for logic and I/O pins. |
| VREF+ | 16 | 29 | K3 | I | Analog | Analog voltage reference (high) input. |
| VREF- | 15 | 28 | L2 | I | Analog | Analog voltage reference (low) input. |

Legend: CMOS = CMOS compatible input or output Analog = Analog input P = Power
 ST = Schmitt Trigger input with CMOS levels O = Output I = Input
 TTL = TTL input buffer

Note 1: Pin numbers are provided for reference only. See the “[Pin Diagrams](#)” section for device pin availability.

PIC32MX3XX/4XX

NOTES:

2.0 GUIDELINES FOR GETTING STARTED WITH 32-BIT MICROCONTROLLERS

Note 1: This data sheet summarizes the features of the PIC32MX3XX/4XX family of devices. It is not intended to be a comprehensive reference source. To complement the information in this data sheet, refer to the “PIC32 Family Reference Manual”, which is available from the Microchip web site (www.microchip.com/PIC32).

2: Some registers and associated bits described in this section may not be available on all devices. Refer to [Section 4.0 “Memory Organization”](#) in this data sheet for device-specific register and bit information.

2.1 Basic Connection Requirements

Getting started with the PIC32MX3XX/4XX family of 32-bit Microcontrollers (MCUs) requires attention to a minimal set of device pin connections before proceeding with development. The following is a list of pin names, which must always be connected:

- All VDD and VSS pins
(see [Section 2.2 “Decoupling Capacitors”](#))
- All AVDD and AVSS pins (regardless if ADC module is not used)
(see [Section 2.2 “Decoupling Capacitors”](#))
- VCAP/VCORE
(see [Section 2.3 “Capacitor on Internal Voltage Regulator \(VCAP/VCORE\)”](#))
- MCLR pin
(see [Section 2.4 “Master Clear \(MCLR\) Pin”](#))
- PGECx/PGEDx pins used for In-Circuit Serial Programming™ (ICSP™) and debugging purposes
(see [Section 2.5 “ICSP Pins”](#))
- OSC1 and OSC2 pins when external oscillator source is used
(see [Section 2.8 “External Oscillator Pins”](#))

Additionally, the following pins may be required:

- VREF+/VREF- pins used when external voltage reference for ADC module is implemented

Note: The AVDD and AVSS pins must be connected independent of ADC use and ADC voltage reference source.

2.2 Decoupling Capacitors

The use of decoupling capacitors on every pair of power supply pins, such as VDD, VSS, AVDD and AVSS is required. See [Figure 2-1](#).

Consider the following criteria when using decoupling capacitors:

- **Value and type of capacitor:** Recommendation of 0.1 μ F (100 nF), 10-20V. This capacitor should be a low-ESR and have resonance frequency in the range of 20 MHz and higher. It is recommended that ceramic capacitors be used.
- **Placement on the printed circuit board:** The decoupling capacitors should be placed as close to the pins as possible. It is recommended to place the capacitors on the same side of the board as the device. If space is constricted, the capacitor can be placed on another layer on the PCB using a via; however, ensure that the trace length from the pin to the capacitor is within one-quarter inch (6 mm) in length.
- **Handling high frequency noise:** If the board is experiencing high frequency noise, upward of tens of MHz, add a second ceramic-type capacitor in parallel to the above described decoupling capacitor. The value of the second capacitor can be in the range of 0.01 μ F to 0.001 μ F. Place this second capacitor next to the primary decoupling capacitor. In high-speed circuit designs, consider implementing a decade pair of capacitances as close to the power and ground pins as possible. For example, 0.1 μ F in parallel with 0.001 μ F.
- **Maximizing performance:** On the board layout from the power supply circuit, run the power and return traces to the decoupling capacitors first, and then to the device pins. This ensures that the decoupling capacitors are first in the power chain. Equally important is to keep the trace length between the capacitor and the power pins to a minimum thereby reducing PCB track inductance.

PIC32MX3XX/4XX

FIGURE 2-1: RECOMMENDED MINIMUM CONNECTION

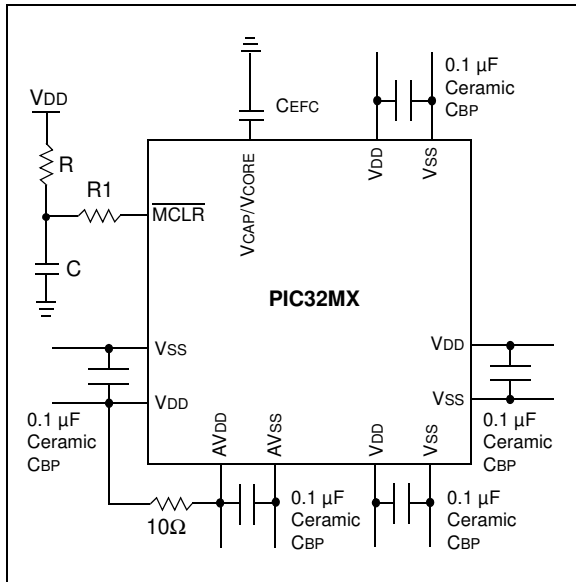

2.2.1 BULK CAPACITORS

The use of a bulk capacitor is recommended to improve power supply stability. Typical values range from 4.7 μF to 47 μF . This capacitor should be located as close to the device as possible.

2.3 Capacitor on Internal Voltage Regulator (VCAP/VCORE)

2.3.1 INTERNAL REGULATOR MODE

A low-ESR ($< 1 \text{ Ohm}$) capacitor is required on the VCAP/VCORE pin, which is used to stabilize the internal voltage regulator output. The VCAP/VCORE pin must not be connected to VDD, and must have a CEFC capacitor, with at least a 6V rating, connected to ground. The type can be ceramic or tantalum. Refer to [Section 29.0 “Electrical Characteristics”](#) for additional information on CEFC specifications. This mode is enabled by connecting the ENVREG pin to VDD.

2.3.2 EXTERNAL REGULATOR MODE

In this mode the core voltage is supplied externally through the VCORE/VCAP pin. A low-ESR capacitor of 10 μF is recommended on the VCAP/VCORE pin. This mode is enabled by grounding the ENVREG pin.

The placement of this capacitor should be close to the VCAP/VCORE. It is recommended that the trace length not exceed one-quarter inch (6 mm). Refer to [Section 26.3 “On-Chip Voltage Regulator”](#) for details.

2.4 Master Clear ($\overline{\text{MCLR}}$) Pin

The $\overline{\text{MCLR}}$ pin provides for two specific device functions:

- Device Reset
- Device Programming and Debugging

Pulling The $\overline{\text{MCLR}}$ pin low generates a device reset. [Figure 2-2](#) illustrates a typical MCLR circuit. During device programming and debugging, the resistance and capacitance that can be added to the pin must be considered. Device programmers and debuggers drive the MCLR pin. Consequently, specific voltage levels (V_{IH} and V_{IL}) and fast signal transitions must not be adversely affected. Therefore, specific values of R and C will need to be adjusted based on the application and PCB requirements.

For example, as illustrated in [Figure 2-2](#), it is recommended that the capacitor C, be isolated from the $\overline{\text{MCLR}}$ pin during programming and debugging operations.

Place the components shown in [Figure 2-2](#) within one-quarter inch (6 mm) from the $\overline{\text{MCLR}}$ pin.

FIGURE 2-2: EXAMPLE OF $\overline{\text{MCLR}}$ PIN CONNECTIONS

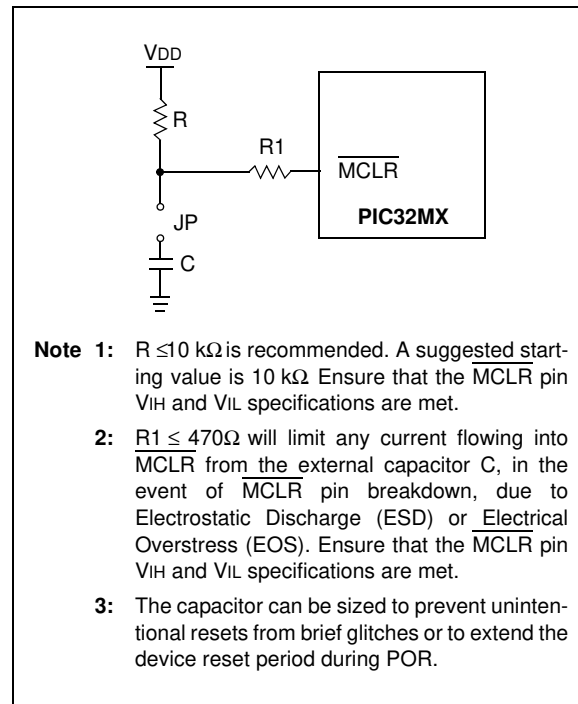

2.5 ICSP Pins

The PGECx and PGEDx pins are used for In-Circuit Serial Programming™ (ICSP™) and debugging purposes. It is recommended to keep the trace length between the ICSP connector and the ICSP pins on the device as short as possible. If the ICSP connector is expected to experience an ESD event, a series resistor is recommended, with the value in the range of a few tens of Ohms, not to exceed 100 Ohms.

Pull-up resistors, series diodes and capacitors on the PGECx and PGEDx pins are not recommended as they will interfere with the programmer/debugger communications to the device. If such discrete components are an application requirement, they should be removed from the circuit during programming and debugging. Alternately, refer to the AC/DC characteristics and timing requirements information in the respective device Flash programming specification for information on capacitive loading limits and pin input voltage high (V_{IH}) and input low (V_{IL}) requirements.

Ensure that the “Communication Channel Select” (i.e., PGECx/PGEDx pins) programmed into the device matches the physical connections for the ICSP to MPLAB® ICD 2, MPLAB ICD 3 or MPLAB REAL ICE™.

For more information on ICD 2, ICD 3 and REAL ICE connection requirements, refer to the following documents that are available on the Microchip web site.

- “MPLAB® ICD 2 In-Circuit Debugger User’s Guide” DS51331
- “Using MPLAB® ICD 2” (poster) DS51265
- “MPLAB® ICD 2 Design Advisory” DS51566
- “Using MPLAB® ICD 3” (poster) DS51765
- “MPLAB® ICD 3 Design Advisory” DS51764
- “MPLAB® REAL ICE™ In-Circuit Debugger User’s Guide” DS51616
- “Using MPLAB® REAL ICE™” (poster) DS51749

2.6 JTAG

The TMS, TDO, TDI and TCK pins are used for testing and debugging according to the Joint Test Action Group (JTAG) standard. It is recommended to keep the trace length between the JTAG connector and the JTAG pins on the device as short as possible. If the JTAG connector is expected to experience an ESD event, a series resistor is recommended, with the value in the range of a few tens of Ohms, not to exceed 100 Ohms.

Pull-up resistors, series diodes and capacitors on the TMS, TDO, TDI and TCK pins are not recommended as they will interfere with the programmer/debugger communications to the device. If such discrete components are an application requirement, they should be removed from the circuit during programming and debugging. Alternately, refer to the AC/DC characteristics and timing requirements information in the respective device Flash programming specification for information on capacitive loading limits and pin input voltage high (V_{IH}) and input low (V_{IL}) requirements.

2.7 Trace

The trace pins can be connected to a hardware-trace-enabled programmer to provide a compress real time instruction trace. When used for trace the TRD3, TRD2, TRD1, TRD0 and TRCLK pins should be dedicated for this use. The trace hardware requires a 22 Ohm series resistor between the trace pins and the trace connector.

2.8 External Oscillator Pins

Many MCUs have options for at least two oscillators: a high-frequency primary oscillator and a low-frequency secondary oscillator (refer to [Section 8.0 “Oscillator Configuration”](#) for details).

The oscillator circuit should be placed on the same side of the board as the device. Also, place the oscillator circuit close to the respective oscillator pins, not exceeding one-half inch (12 mm) distance between them. The load capacitors should be placed next to the oscillator itself, on the same side of the board. Use a grounded copper pour around the oscillator circuit to isolate them from surrounding circuits. The grounded copper pour should be routed directly to the MCU ground. Do not run any signal traces or power traces inside the ground pour. Also, if using a two-sided board, avoid any traces on the other side of the board where the crystal is placed. A suggested layout is illustrated in [Figure 2-3](#).

FIGURE 2-3: SUGGESTED PLACEMENT OF THE OSCILLATOR CIRCUIT

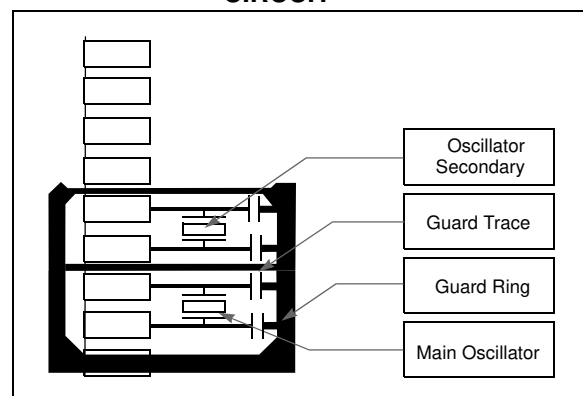

PIC32MX3XX/4XX

2.9 Configuration of Analog and Digital Pins During ICSP Operations

If MPLAB ICD 2, ICD 3 or REAL ICE is selected as a debugger, it automatically initializes all of the Analog-to-Digital input pins (ANx) as “digital” pins by setting all bits in the ADPCFG register.

The bits in this register that correspond to the Analog-to-Digital pins that are initialized by MPLAB ICD 2, ICD 3 or REAL ICE, must not be cleared by the user application firmware; otherwise, communication errors will result between the debugger and the device.

If your application needs to use certain Analog-to-Digital pins as analog input pins during the debug session, the user application must clear the corresponding bits in the ADPCFG register during initialization of the ADC module.

When MPLAB ICD 2, ICD 3 or REAL ICE is used as a programmer, the user application firmware must correctly configure the ADPCFG register. Automatic initialization of this register is only done during debugger operation. Failure to correctly configure the register(s) will result in all Analog-to-Digital pins being recognized as analog input pins, resulting in the port value being read as a logic ‘0’, which may affect user application functionality.

2.10 Unused I/Os

Unused I/O pins should not be allowed to float as inputs. They can be configured as outputs and driven to a logic-low state.

Alternately, inputs can be reserved by connecting the pin to VSS through a 1k to 10k resistor and configuring the pin as an input.

2.11 Referenced Sources

This device data sheet is based on the following individual chapters of the *"PIC32 Family Reference Manual"*. These documents should be considered as the general reference for the operation of a particular module or device feature.

Note 1: To access the documents listed below, browse to the documentation section of the [PIC32MX460F512L](#) product page on the Microchip web site (www.microchip.com) or select a family reference manual section from the following list.

In addition to parameters, features, and other documentation, the resulting page provides links to the related family reference manual sections.

- **Section 1. "Introduction"** (DS61127)
- **Section 2. "CPU"** (DS61113)
- **Section 3. "Memory Organization"** (DS61115)
- **Section 4. "Prefetch Cache"** (DS61119)
- **Section 5. "Flash Program Memory"** (DS61121)
- **Section 6. "Oscillator Configuration"** (DS61112)
- **Section 7. "Resets"** (DS61118)
- **Section 8. "Interrupt Controller"** (DS61108)
- **Section 9. "Watchdog Timer and Power-up Timer"** (DS61114)
- **Section 10. "Power-Saving Features"** (DS61130)
- **Section 12. "I/O Ports"** (DS61120)
- **Section 13. "Parallel Master Port (PMP)"** (DS61128)
- **Section 14. "Timers"** (DS61105)
- **Section 15. "Input Capture"** (DS61122)
- **Section 16. "Output Compare"** (DS61111)
- **Section 17. "10-bit Analog-to-Digital Converter (ADC)"** (DS61104)
- **Section 19. "Comparator"** (DS61110)
- **Section 20. "Comparator Voltage Reference (CVREF)"** (DS61109)
- **Section 21. "Universal Asynchronous Receiver Transmitter (UART)"** (DS61107)
- **Section 23. "Serial Peripheral Interface (SPI)"** (DS61106)
- **Section 24. "Inter-Integrated Circuit™ (I²C™)"** (DS61116)
- **Section 27. "USB On-The-Go (OTG)"** (DS61126)
- **Section 29. "Real-Time Clock and Calendar (RTCC)"** (DS61125)
- **Section 31. "Direct Memory Access (DMA) Controller"** (DS61117)
- **Section 32. "Configuration"** (DS61124)
- **Section 33. "Programming and Diagnostics"** (DS61129)

PIC32MX3XX/4XX

NOTES:

3.0 CPU

Note 1: This data sheet summarizes the features of the PIC32MX3XX/4XX family of devices. It is not intended to be a comprehensive reference source. To complement the information in this data sheet, refer to **Section 2. “CPU”** (DS61113) of the *“PIC32 Family Reference Manual”*, which is available from the Microchip web site (www.microchip.com/PIC32). Resources for the MIPS32® M4K® Processor Core are available at: www.mips.com/products/cores/32-64-bit-cores/mips32-m4k/.

2: Some registers and associated bits described in this section may not be available on all devices. Refer to **Section 4.0 “Memory Organization”** in this data sheet for device-specific register and bit information.

The MIPS32® M4K® Processor Core is the heart of the PIC32MX3XX/4XX family processor. The CPU fetches instructions, decodes each instruction, fetches source operands, executes each instruction and writes the results of instruction execution to the proper destinations.

3.1 Features

- 5-stage pipeline
- 32-bit Address and Data Paths
- MIPS32 Enhanced Architecture (Release 2)
 - Multiply-Accumulate and Multiply-Subtract Instructions
 - Targeted Multiply Instruction
 - Zero/One Detect Instructions
 - WAIT Instruction
 - Conditional Move Instructions (MOVN, MOVZ)
 - Vectored interrupts
 - Programmable exception vector base
- Atomic interrupt enable/disable
- GPR shadow registers to minimize latency for interrupt handlers
- Bit field manipulation instructions
- MIPS16e® Code Compression
 - 16-bit encoding of 32-bit instructions to improve code density
 - Special PC-relative instructions for efficient loading of addresses and constants
 - SAVE & RESTORE macro instructions for setting up and tearing down stack frames within subroutines
 - Improved support for handling 8 and 16-bit data types
- Simple Fixed Mapping Translation (FMT) mechanism
- Simple Dual Bus Interface
 - Independent 32-bit address and data busses
 - Transactions can be aborted to improve interrupt latency
- Autonomous Multiply/Divide Unit
 - Maximum issue rate of one 32x16 multiply per clock
 - Maximum issue rate of one 32x32 multiply every other clock
 - Early-in iterative divide. Minimum 11 and maximum 34 clock latency (dividend (rs) sign extension-dependent)
- Power Control
 - Minimum frequency: 0 MHz
 - Low-Power mode (triggered by WAIT instruction)
 - Extensive use of local gated clocks
- EJTAG Debug and Instruction Trace
 - Support for single stepping
 - Virtual instruction and data address/value breakpoints
 - PC tracing with trace compression

FIGURE 3-1: MIPS® M4K® BLOCK DIAGRAM

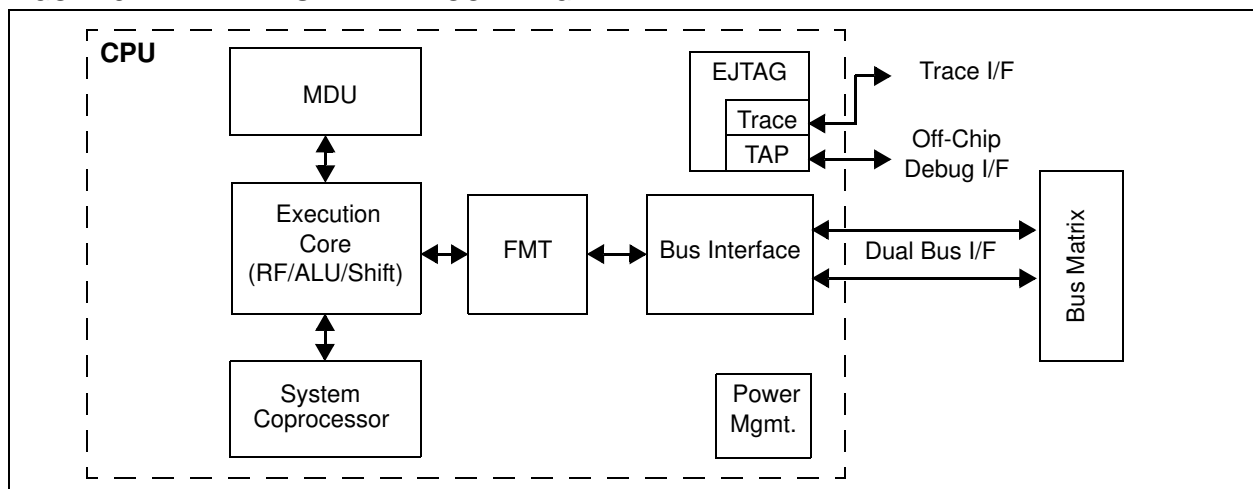

PIC32MX3XX/4XX

3.2 Architecture Overview

The MIPS32[®] M4K[®] Processor Core contains several logic blocks working together in parallel, providing an efficient high performance computing engine. The following blocks are included with the core:

- Execution Unit
- Multiply/Divide Unit (MDU)
- System Control Coprocessor (CP0)
- Fixed Mapping Translation (FMT)
- Dual Internal Bus interfaces
- Power Management
- MIPS16e Support
- Enhanced JTAG (EJTAG) Controller

3.2.1 EXECUTION UNIT

The MIPS32[®] M4K[®] Processor Core execution unit implements a load/store architecture with single-cycle ALU operations (logical, shift, add, subtract) and an autonomous multiply/divide unit. The core contains thirty-two 32-bit general purpose registers used for integer operations and address calculation. One additional register file shadow set (containing thirty-two registers) is added to minimize context switching overhead during interrupt/exception processing. The register file consists of two read ports and one write port and is fully bypassed to minimize operation latency in the pipeline.

The execution unit includes:

- 32-bit adder used for calculating the data address
- Address unit for calculating the next instruction address
- Logic for branch determination and branch target address calculation
- Load aligner
- Bypass multiplexers used to avoid stalls when executing instructions streams where data producing instructions are followed closely by consumers of their results
- Leading Zero/One detect unit for implementing the CLZ and CLO instructions
- Arithmetic Logic Unit (ALU) for performing bitwise logical operations
- Shifter and Store Aligner

3.2.2 MULTIPLY/DIVIDE UNIT (MDU)

The MIPS32[®] M4K[®] Processor Core includes a multiply/divide unit (MDU) that contains a separate pipeline for multiply and divide operations. This pipeline operates in parallel with the integer unit (IU) pipeline and does not stall when the IU pipeline stalls. This allows MDU operations to be partially masked by system stalls and/or other integer unit instructions.

The high-performance MDU consists of a 32x16 booth recoded multiplier, result/accumulation registers (HI and LO), a divide state machine, and the necessary multiplexers and control logic. The first number shown ('32' of 32x16) represents the *rs* operand. The second number ('16' of 32x16) represents the *rt* operand. The PIC32MX core only checks the value of the latter (*rt*) operand to determine how many times the operation must pass through the multiplier. The 16x16 and 32x16 operations pass through the multiplier once. A 32x32 operation passes through the multiplier twice.

The MDU supports execution of one 16x16 or 32x16 multiply operation every clock cycle; 32x32 multiply operations can be issued every other clock cycle. Appropriate interlocks are implemented to stall the issuance of back-to-back 32x32 multiply operations. The multiply operand size is automatically determined by logic built into the MDU.

Divide operations are implemented with a simple 1 bit per clock iterative algorithm. An early-in detection checks the sign extension of the dividend (*rs*) operand. If *rs* is 8 bits wide, 23 iterations are skipped. For a 16-bit-wide *rs*, 15 iterations are skipped, and for a 24-bit-wide *rs*, 7 iterations are skipped. Any attempt to issue a subsequent MDU instruction while a divide is still active causes an IU pipeline stall until the divide operation is completed.

Table 3-1 lists the repeat rate (peak issue rate of cycles until the operation can be reissued) and latency (number of cycles until a result is available) for the PIC32MX core multiply and divide instructions. The approximate latency and repeat rates are listed in terms of pipeline clocks.

TABLE 3-1: MIPS® M4K® PROCESSOR CORE HIGH-PERFORMANCE INTEGER MULTIPLY/DIVIDE UNIT LATENCIES AND REPEAT RATES

| Opcode | Operand Size (mul <i>rt</i>) (div <i>rs</i>) | Latency | Repeat Rate |
|---------------------------------------|--|---------|-------------|
| MULT/MULTU, MADD/MADDU, MSUB/MSUBU | 16 bits | 1 | 1 |
| | 32 bits | 2 | 2 |
| MUL | 16 bits | 2 | 1 |
| | 32 bits | 3 | 2 |
| DIV/DIVU | 8 bits | 12 | 11 |
| | 16 bits | 19 | 18 |
| | 24 bits | 26 | 25 |
| | 32 bits | 33 | 32 |

The MIPS architecture defines that the result of a multiply or divide operation be placed in the HI and LO registers. Using the Move-From-HI (MFHI) and Move-From-LO (MFLO) instructions, these values can be transferred to the general purpose register file.

In addition to the HI/LO targeted operations, the MIPS32 architecture also defines a multiply instruction, MUL, which places the least significant results in the primary register file instead of the HI/LO register pair. By avoiding the explicit MFLO instruction, required when using the LO register, and by supporting multiple destination registers, the throughput of multiply-intensive operations is increased.

Two other instructions, multiply-add (MADD) and multiply-subtract (MSUB), are used to perform the multiply-accumulate and multiply-subtract operations. The MADD instruction multiplies two numbers and then adds

the product to the current contents of the HI and LO registers. Similarly, the MSUB instruction multiplies two operands and then subtracts the product from the HI and LO registers. The MADD and MSUB operations are commonly used in DSP algorithms.

3.2.3 SYSTEM CONTROL COPROCESSOR (CP0)

In the MIPS architecture, CP0 is responsible for the virtual-to-physical address translation, the exception control system, the processor's diagnostics capability, the operating modes (kernel, user and debug), and whether interrupts are enabled or disabled. Configuration information, such as presence of options like MIPS16e, is also available by accessing the CP0 registers, listed in [Table 3-2](#).

TABLE 3-2: COPROCESSOR 0 REGISTERS

| Register Number | Register Name | Function |
|-----------------|-------------------------|---|
| 0-6 | Reserved | Reserved |
| 7 | HWREna | Enables access via the RDHWR instruction to selected hardware registers |
| 8 | BadVAddr ⁽¹⁾ | Reports the address for the most recent address-related exception |
| 9 | Count ⁽¹⁾ | Processor cycle count |
| 10 | Reserved | Reserved |
| 11 | Compare ⁽¹⁾ | Timer interrupt control |
| 12 | Status ⁽¹⁾ | Processor status and control |
| 12 | IntCtl ⁽¹⁾ | Interrupt system status and control |
| 12 | SRSCtl ⁽¹⁾ | Shadow register set status and control |
| 12 | SRSMap ⁽¹⁾ | Provides mapping from vectored interrupt to a shadow set |
| 13 | Cause ⁽¹⁾ | Cause of last general exception |
| 14 | EPC ⁽¹⁾ | Program counter at last exception |
| 15 | PRId | Processor identification and revision |
| 15 | EBASE | Exception vector base register |
| 16 | Config | Configuration register |
| 16 | Config1 | Configuration register 1 |
| 16 | Config2 | Configuration register 2 |
| 16 | Config3 | Configuration register 3 |

PIC32MX3XX/4XX

TABLE 3-2: COPROCESSOR 0 REGISTERS (CONTINUED)

| Register Number | Register Name | Function |
|-----------------|-------------------------|---|
| 17-22 | Reserved | Reserved |
| 23 | Debug ⁽²⁾ | Debug control and exception status |
| 24 | DEPC ⁽²⁾ | Program counter at last debug exception |
| 25-29 | Reserved | Reserved |
| 30 | ErrorEPC ⁽¹⁾ | Program counter at last error |
| 31 | DESAVE ⁽²⁾ | Debug handler scratchpad register |

Note 1: Registers used in exception processing.

2: Registers used during debug.

Coprocessor 0 also contains the logic for identifying and managing exceptions. Exceptions can be caused by a variety of sources, including alignment errors in data, external events or program errors. [Table 3-3](#) shows the exception types in order of priority.

TABLE 3-3: PIC32MX3XX/4XX FAMILY CORE EXCEPTION TYPES

| Exception | Description |
|-----------|--|
| Reset | Assertion \overline{MCLR} or a Power-on Reset (POR) |
| DSS | EJTAG Debug Single Step |
| DINT | EJTAG Debug Interrupt. Caused by the assertion of the external <i>EJ_DINT</i> input, or by setting the <i>EjtagBrk</i> bit in the ECR register |
| NMI | Assertion of NMI signal |
| Interrupt | Assertion of unmasked hardware or software interrupt signal |
| DIB | EJTAG debug hardware instruction break matched |
| AdEL | Fetch address alignment error Fetch reference to protected address |
| IBE | Instruction fetch bus error |
| DBp | EJTAG Breakpoint (execution of <i>SDBBP</i> instruction) |
| Sys | Execution of <i>SYSCALL</i> instruction |
| Bp | Execution of <i>BREAK</i> instruction |
| RI | Execution of a Reserved Instruction |
| CpU | Execution of a coprocessor instruction for a coprocessor that is not enabled |
| CEU | Execution of a <i>CorExtend</i> instruction when <i>CorExtend</i> is not enabled |
| Ov | Execution of an arithmetic instruction that overflowed |
| Tr | Execution of a trap (when trap condition is true) |
| DDBL/DDBS | EJTAG Data Address Break (address only) or EJTAG Data Value Break on Store (address + value) |
| AdEL | Load address alignment error Load reference to protected address |
| AdES | Store address alignment error Store to protected address |
| DBE | Load or store bus error |
| DDBL | EJTAG data hardware breakpoint matched in load data compare |

3.3 Power Management

The MIPS32[®] M4K[®] Processor Core offers a number of power management features, including low-power design, active power management and power-down modes of operation. The core is a static design that supports slowing or halting the clocks, which reduces system power consumption during idle periods.

3.3.1 INSTRUCTION-CONTROLLED POWER MANAGEMENT

The mechanism for invoking power-down mode is through execution of the `WAIT` instruction. For more information on power management, see [Section 25.0 “Power-Saving Features”](#).

3.3.2 LOCAL CLOCK GATING

The majority of the power consumed by the PIC32MX3XX/4XX family core is in the clock tree and clocking registers. The PIC32MX family uses extensive use of local gated-clocks to reduce this dynamic power consumption.

3.4 EJTAG Debug Support

The MIPS32[®] M4K[®] Processor Core provides for an Enhanced JTAG (EJTAG) interface for use in the software debug of application and kernel code. In addition to standard user mode and kernel modes of operation, the core provides a Debug mode that is entered after a debug exception (derived from a hardware breakpoint, single-step exception, etc.) is taken and continues until a debug exception return (`DERET`) instruction is executed. During this time, the processor executes the debug exception handler routine.

The EJTAG interface operates through the Test Access Port (TAP), a serial communication port used for transferring test data in and out of the core. In addition to the standard JTAG instructions, special instructions defined in the EJTAG specification define what registers are selected and how they are used.

PIC32MX3XX/4XX

NOTES:

4.0 MEMORY ORGANIZATION

Note 1: This data sheet summarizes the features of the PIC32MX3XX/4XX family of devices. It is not intended to be a comprehensive reference source. To complement the information in this data sheet, refer to **Section 3. “Memory Organization”** (DS61115) of the *“PIC32 Family Reference Manual”*, which is available from the Microchip web site (www.microchip.com/PIC32).

PIC32MX3XX/4XX microcontrollers provide 4 GB of unified virtual memory address space. All memory regions including program, data memory, SFRs and Configuration registers reside in this address space at their respective unique addresses. The program and data memories can be optionally partitioned into user and kernel memories. In addition, the data memory can be made executable, allowing PIC32MX3XX/4XX to execute from data memory.

4.1 Key Features

- 32-bit native data width
- Separate User and Kernel mode address space
- Flexible program Flash memory partitioning
- Flexible data RAM partitioning for data and program space
- Separate boot Flash memory for protected code
- Robust bus exception handling to intercept runaway code
- Simple memory mapping with Fixed Mapping Translation (FMT) unit
- Cacheable and non-cacheable address regions

4.2 PIC32MX3XX/4XX Memory Layout

PIC32MX3XX/4XX microcontrollers implement two address spaces: Virtual and Physical. All hardware resources such as program memory, data memory and peripherals are located at their respective physical addresses. Virtual addresses are exclusively used by the CPU to fetch and execute instructions as well as access peripherals. Physical addresses are used by peripherals such as DMA and Flash controller that access memory independently of CPU.

PIC32MX3XX/4XX

FIGURE 4-1: MEMORY MAP ON RESET FOR PIC32MX320F032H AND PIC32MX420F032H DEVICES⁽¹⁾

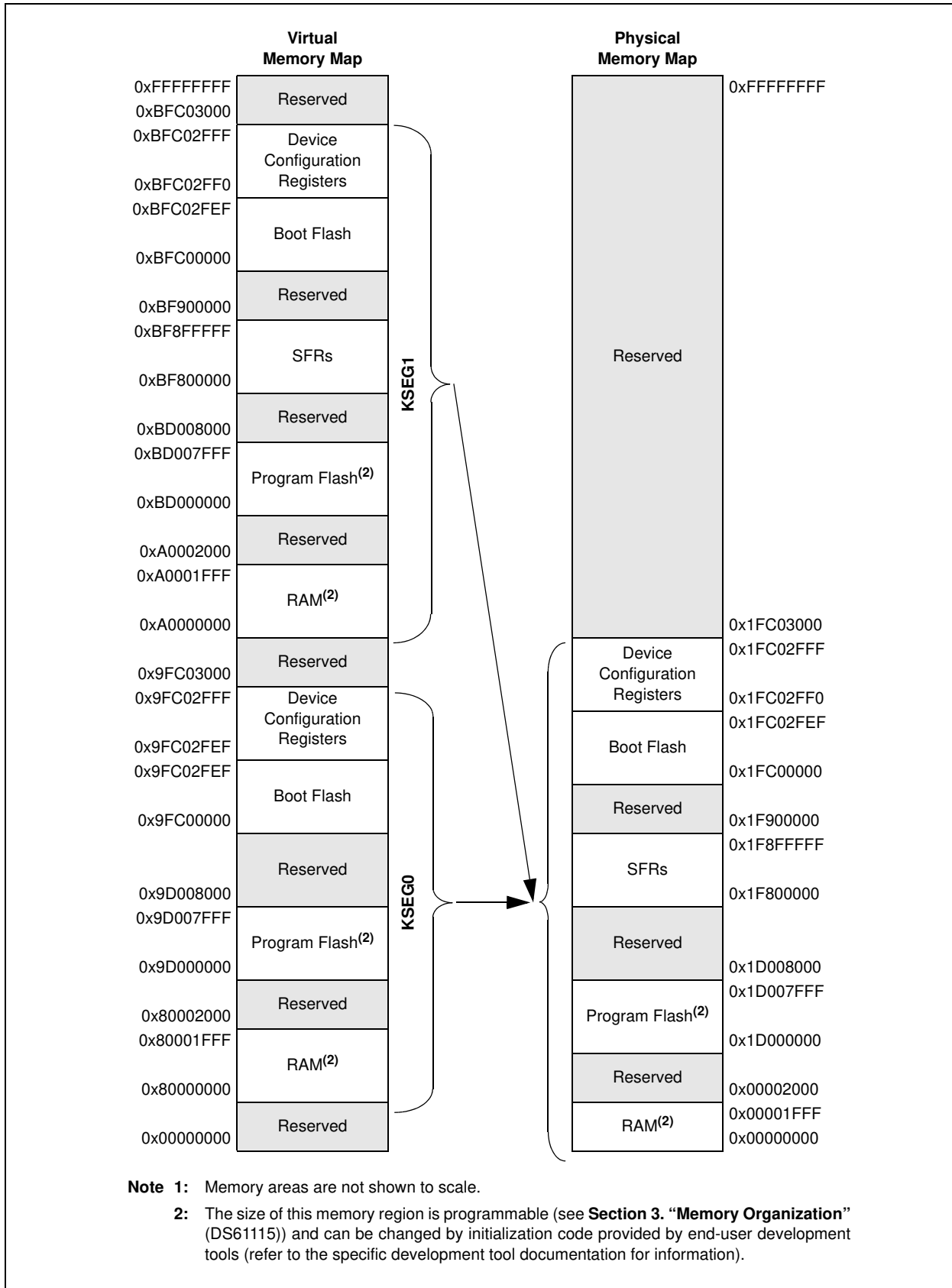
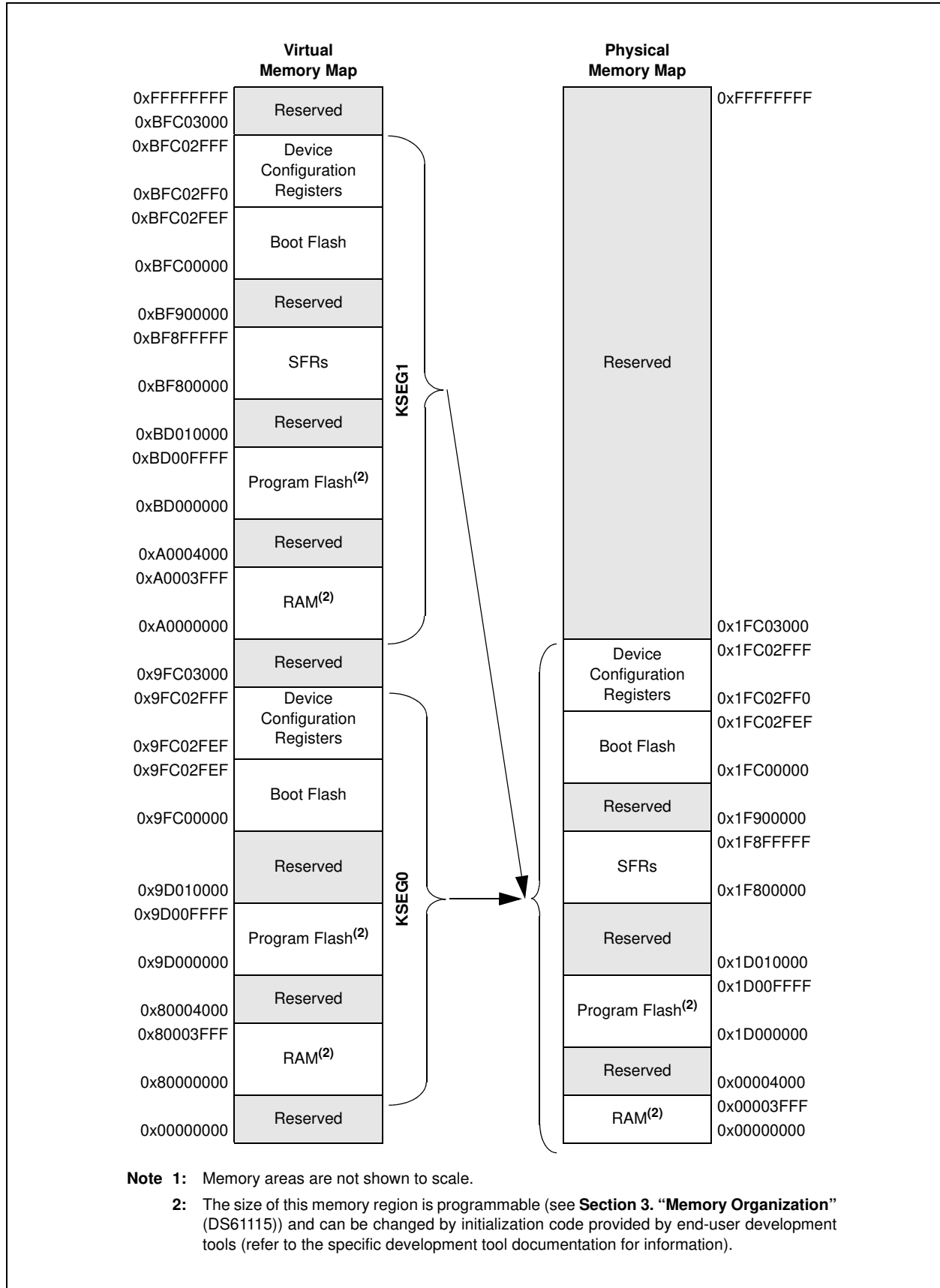

FIGURE 4-2: MEMORY MAP ON RESET FOR PIC32MX320F064H DEVICE⁽¹⁾



PIC32MX3XX/4XX

FIGURE 4-3: MEMORY MAP ON RESET FOR PIC32MX320F128H AND PIC32MX320F128L DEVICES⁽¹⁾

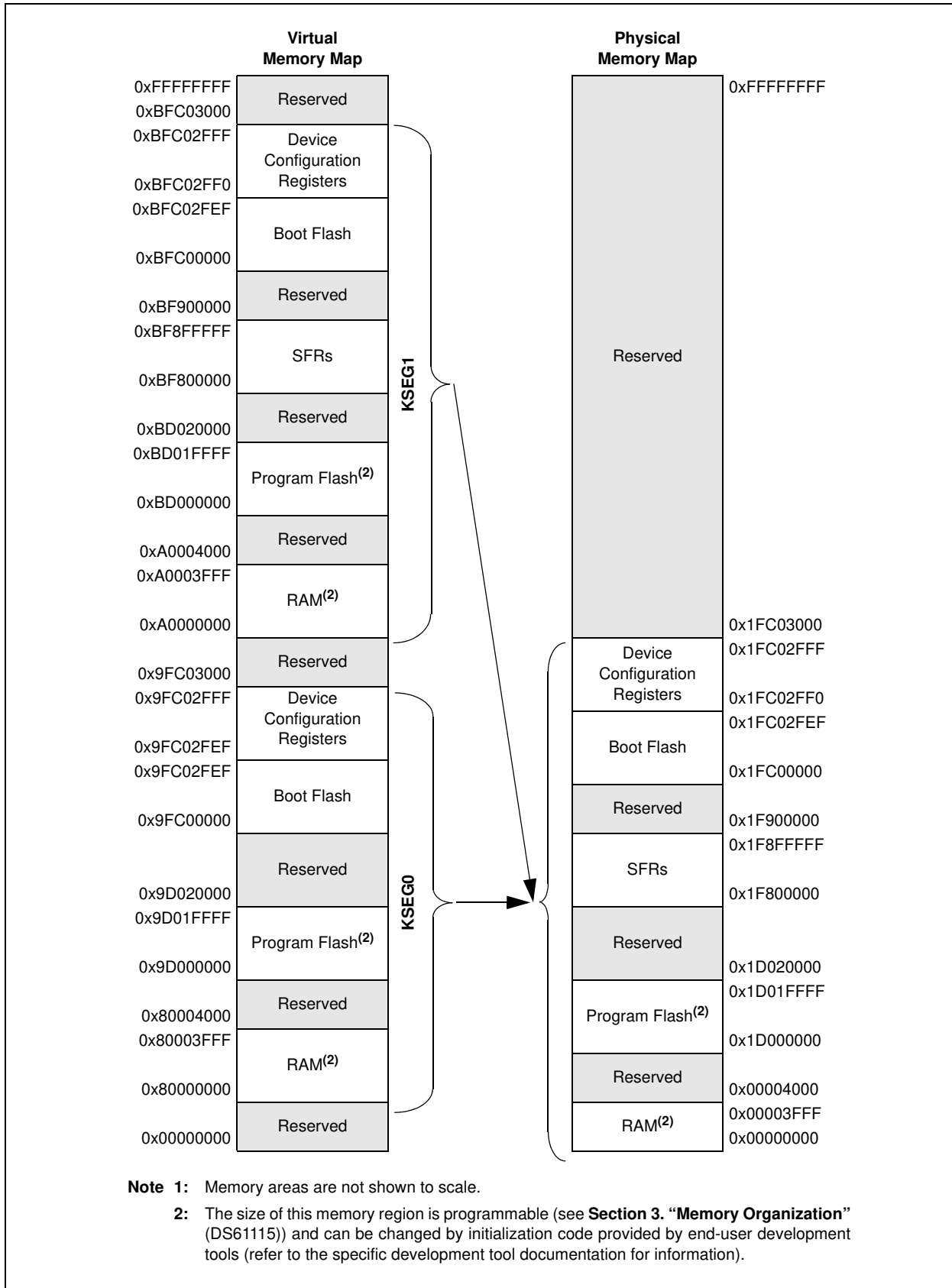
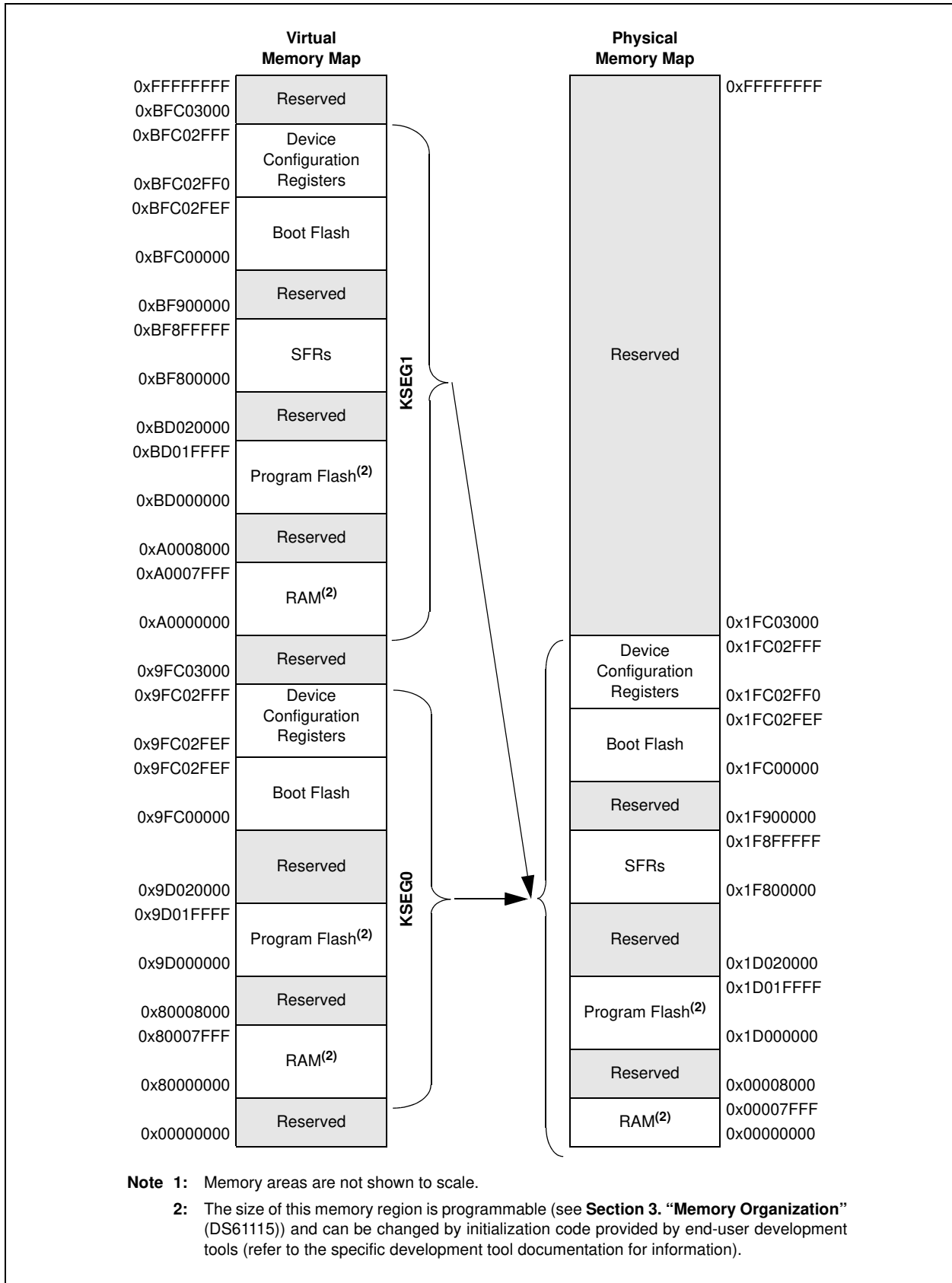

FIGURE 4-4: MEMORY MAP ON RESET FOR PIC32MX340F128H, PIC32MX340F128L, PIC32MX440F128H AND PIC32MX440F128L DEVICES⁽¹⁾



PIC32MX3XX/4XX

FIGURE 4-5: MEMORY MAP ON RESET FOR PIC32MX340F256H, PIC32MX360F256L, PIC32MX440F256H AND PIC32MX460F256L DEVICES⁽¹⁾

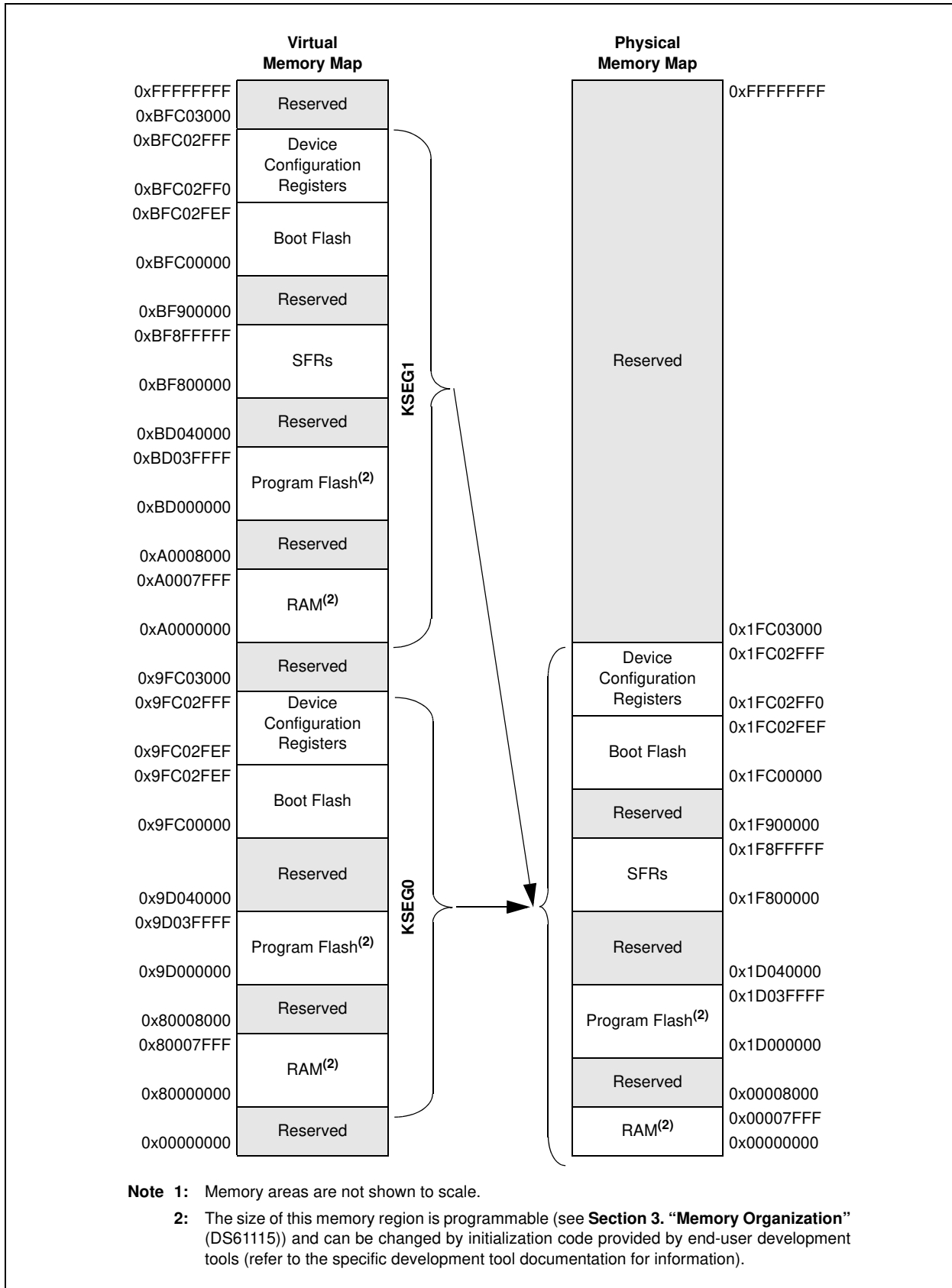

FIGURE 4-6: MEMORY MAP ON RESET FOR PIC32MX340F512H, PIC32MX360F512L, PIC32MX440F512H AND PIC32MX460F512L DEVICES⁽¹⁾

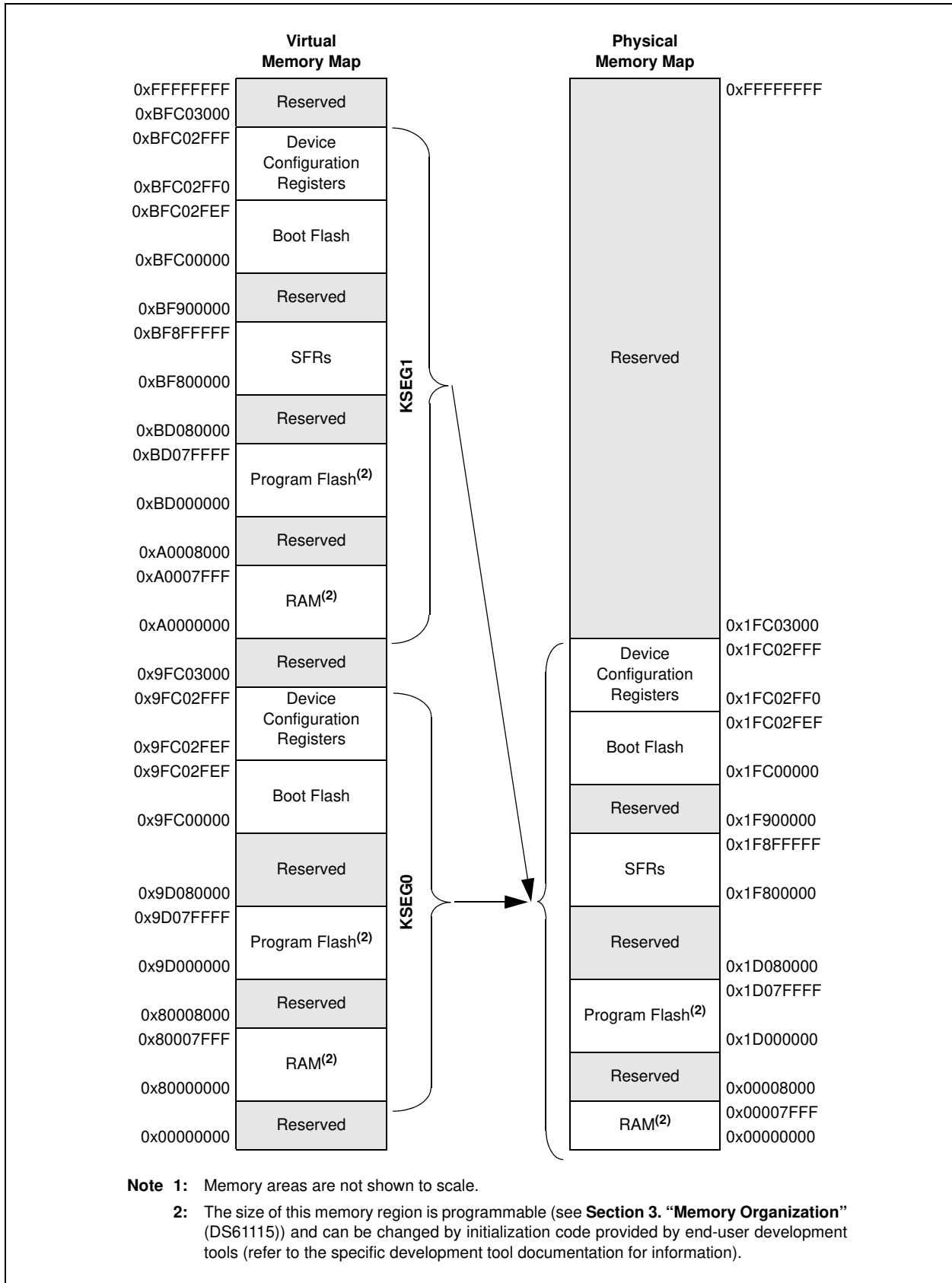

TABLE 4-1: BUS MATRIX REGISTERS MAP

| Virtual Address (BF88_#) | Register Name | Bit Range | Bits | | | | | | | | | | | | | | | All Resets | | |
|-----------------------------|-----------------------------|-----------|-----------------|-------|-------|-------|-------|-----------|------|------|------|------|------|------|-----------------|-----------|-----------|---------------|----------|------|
| | | | 31/15 | 30/14 | 29/13 | 28/12 | 27/11 | 26/10 | 25/9 | 24/8 | 23/7 | 22/6 | 21/5 | 20/4 | 19/3 | 18/2 | 17/1 | | 16/0 | |
| 2000 | BMX CON ⁽¹⁾ | 31:16 | — | — | — | — | — | BMXCHEDMA | — | — | — | — | — | — | BMXERRIXI | BMXERRICD | BMXERRDMA | BMXERRDS | BMXERRIS | 001F |
| | | 15:0 | — | — | — | — | — | — | — | — | — | — | — | — | — | — | — | — | — | — |
| 2010 | BMX DKPBA ⁽¹⁾ | 31:16 | — | — | — | — | — | — | — | — | — | — | — | — | — | — | — | — | — | 0000 |
| | | 15:0 | BMXDKPBA<15:0> | | | | | | | | | | | | | | | 0000 | | |
| 2020 | BMX DUDBA ⁽¹⁾ | 31:16 | — | — | — | — | — | — | — | — | — | — | — | — | — | — | — | — | — | 0000 |
| | | 15:0 | BMXDUDBA<15:0> | | | | | | | | | | | | | | | 0000 | | |
| 2030 | BMX DUPBA ⁽¹⁾ | 31:16 | — | — | — | — | — | — | — | — | — | — | — | — | — | — | — | — | — | 0000 |
| | | 15:0 | BMXDUPBA<15:0> | | | | | | | | | | | | | | | 0000 | | |
| 2040 | BMX DRMSZ | 31:16 | BMXDRMSZ<31:0> | | | | | | | | | | | | | | | xxxx | | |
| | | 15:0 | BMXDRMSZ<31:0> | | | | | | | | | | | | | | | xxxx | | |
| 2050 | BMX PUPBA ⁽¹⁾ | 31:16 | — | — | — | — | — | — | — | — | — | — | — | — | BMXPUPBA<19:16> | | | | 0000 | |
| | | 15:0 | BMXPUPBA<15:0> | | | | | | | | | | | | | | | 0000 | | |
| 2060 | BMX PFMSZ | 31:16 | BMXPFMSZ<31:0> | | | | | | | | | | | | | | | xxxx | | |
| | | 15:0 | BMXPFMSZ<31:0> | | | | | | | | | | | | | | | xxxx | | |
| 2070 | BMX BOOTSZ | 31:16 | BMXBOOTSZ<31:0> | | | | | | | | | | | | | | | 0000 | | |
| | | 15:0 | BMXBOOTSZ<31:0> | | | | | | | | | | | | | | | 3000 | | |

Legend: x = unknown value on Reset, — = unimplemented, read as '0'. Reset values are shown in hexadecimal.

Note 1: This register has corresponding CLR, SET, and INV registers at its virtual address, plus an offset of 0x4, 0x8 and 0xC, respectively. See [Section 12.1.1 “CLR, SET and INV Registers”](#) for more information.

TABLE 4-2: INTERRUPT REGISTERS MAP FOR PIC32MX440F128L, PIC32MX460F256L AND PIC32MX460F512L DEVICES ONLY⁽¹⁾

| Virtual Address (BF88_#) | Register Name | Bit Range | Bits | | | | | | | | | | | | | | | | All Resets | | | | |
|-----------------------------|------------------------|-----------|-------------|---------|---------|---------|---------|--------|-------------|-------------|------------|----------|---------|--------|------------|--------|--------|-------------|-------------|------|------|--|------|
| | | | 31/15 | 30/14 | 29/13 | 28/12 | 27/11 | 26/10 | 25/9 | 24/8 | 23/7 | 22/6 | 21/5 | 20/4 | 19/3 | 18/2 | 17/1 | 16/0 | | | | | |
| 1000 | INTCON | 31:16 | — | — | — | — | — | — | — | — | — | — | — | — | — | — | — | SS0 | 0000 | | | | |
| | | 15:0 | — | — | — | MVEC | — | — | — | — | — | — | — | — | INT4EP | INT3EP | INT2EP | INT1EP | INT0EP | 0000 | | | |
| 1010 | INTSTAT ⁽²⁾ | 31:16 | — | — | — | — | — | — | — | — | — | — | — | — | — | — | — | — | 0000 | | | | |
| | | 15:0 | — | — | — | — | — | — | — | — | — | — | — | — | — | — | — | — | — | 0000 | | | |
| 1020 | IPTMR | 31:16 | IPTMR<31:0> | | | | | | | | | | | | | | | | 0000 | | | | |
| | | 15:0 | — | | | | | | | | | | | | | | | | 0000 | | | | |
| 1030 | IFS0 | 31:16 | I2C1MIF | I2C1SIF | I2C1BIF | U1TXIF | U1RXIF | U1EIF | SPI1RXIF | SPI1TXIF | SPI1EIF | OC5IF | IC5IF | T5IF | INT4IF | OC4IF | IC4IF | T4IF | 0000 | | | | |
| | | 15:0 | INT3IF | OC3IF | IC3IF | T3IF | INT2IF | OC2IF | IC2IF | T2IF | INT1IF | OC1IF | IC1IF | T1IF | INT0IF | CS1IF | CS0IF | CTIF | 0000 | | | | |
| 1040 | IFS1 | 31:16 | — | — | — | — | — | — | USBIF | FCEIF | — | — | — | — | DMA3IF | DMA2IF | DMA1IF | DMA0IF | 0000 | | | | |
| | | 15:0 | RTCCIF | FSCMIF | I2C2MIF | I2C2SIF | I2C2BIF | U2TXIF | U2RXIF | U2EIF | SPI2RXIF | SPI2TXIF | SPI2EIF | CMP2IF | CMP1IF | PMPIF | AD1IF | CNIF | 0000 | | | | |
| 1060 | IEC0 | 31:16 | I2C1MIE | I2C1SIE | I2C1BIE | U1TXIE | U1RXIE | U1EIE | SPI1RXIE | SPI1TXIE | SPI1EIE | OC5IE | IC5IE | T5IE | INT4IE | OC4IE | IC4IE | T4IE | 0000 | | | | |
| | | 15:0 | INT3IE | OC3IE | IC3IE | T3IE | INT2IE | OC2IE | IC2IE | T2IE | INT1IE | OC1IE | IC1IE | T1IE | INT0IE | CS1IE | CS0IE | CTIE | 0000 | | | | |
| 1070 | IEC1 | 31:16 | — | — | — | — | — | — | USBIE | FCEIE | — | — | — | — | DMA3IE | DMA2IE | DMA1IE | DMA0IE | 0000 | | | | |
| | | 15:0 | RTCCIE | FSCMIE | I2C2MIE | I2C2SIE | I2C2BIE | U2TXIE | U2RXIE | U2EIE | SPI2RXIE | SPI2TXIE | SPI2EIE | CMP2IE | CMP1IE | PMPIE | AD1IE | CNIE | 0000 | | | | |
| 1090 | IPC0 | 31:16 | — | — | — | — | — | — | INT0IP<2:0> | INT0IS<1:0> | — | — | — | — | — | — | — | CS1IP<2:0> | CS1IS<1:0> | 0000 | | | |
| | | 15:0 | — | — | — | — | — | — | CS0IP<2:0> | CS0IS<1:0> | — | — | — | — | — | — | — | CTIP<2:0> | CTIS<1:0> | 0000 | | | |
| 10A0 | IPC1 | 31:16 | — | — | — | — | — | — | INT1IP<2:0> | INT1IS<1:0> | — | — | — | — | — | — | — | OC1IP<2:0> | OC1IS<1:0> | 0000 | | | |
| | | 15:0 | — | — | — | — | — | — | IC1IP<2:0> | IC1IS<1:0> | — | — | — | — | — | — | — | T1IP<2:0> | T1IS<1:0> | 0000 | | | |
| 10B0 | IPC2 | 31:16 | — | — | — | — | — | — | INT2IP<2:0> | INT2IS<1:0> | — | — | — | — | — | — | — | OC2IP<2:0> | OC2IS<1:0> | 0000 | | | |
| | | 15:0 | — | — | — | — | — | — | IC2IP<2:0> | IC2IS<1:0> | — | — | — | — | — | — | — | T2IP<2:0> | T2IS<1:0> | 0000 | | | |
| 10C0 | IPC3 | 31:16 | — | — | — | — | — | — | INT3IP<2:0> | INT3IS<1:0> | — | — | — | — | — | — | — | OC3IP<2:0> | OC3IS<1:0> | 0000 | | | |
| | | 15:0 | — | — | — | — | — | — | IC3IP<2:0> | IC3IS<1:0> | — | — | — | — | — | — | — | T3IP<2:0> | T3IS<1:0> | 0000 | | | |
| 10D0 | IPC4 | 31:16 | — | — | — | — | — | — | INT4IP<2:0> | INT4IS<1:0> | — | — | — | — | — | — | — | OC4IP<2:0> | OC4IS<1:0> | 0000 | | | |
| | | 15:0 | — | — | — | — | — | — | IC4IP<2:0> | IC4IS<1:0> | — | — | — | — | — | — | — | T4IP<2:0> | T4IS<1:0> | 0000 | | | |
| 10E0 | IPC5 | 31:16 | — | — | — | — | — | — | SPI1IP<2:0> | SPI1IS<1:0> | — | — | — | — | — | — | — | OC5IP<2:0> | OC5IS<1:0> | 0000 | | | |
| | | 15:0 | — | — | — | — | — | — | IC5IP<2:0> | IC5IS<1:0> | — | — | — | — | — | — | — | T5IP<2:0> | T5IS<1:0> | 0000 | | | |
| 10F0 | IPC6 | 31:16 | — | — | — | — | — | — | AD1IP<2:0> | AD1IS<1:0> | — | — | — | — | — | — | — | CNIP<2:0> | CNIS<1:0> | 0000 | | | |
| | | 15:0 | — | — | — | — | — | — | I2C1IP<2:0> | I2C1IS<1:0> | — | — | — | — | — | — | — | U1IP<2:0> | U1IS<1:0> | 0000 | | | |
| 1100 | IPC7 | 31:16 | — | — | — | — | — | — | SPI2IP<2:0> | SPI2IS<1:0> | — | — | — | — | — | — | — | CMP2IP<2:0> | CMP2IS<1:0> | 0000 | | | |
| | | 15:0 | — | — | — | — | — | — | CMP1IP<2:0> | CMP1IS<1:0> | — | — | — | — | — | — | — | PMPIP<2:0> | PMPIS<1:0> | 0000 | | | |
| 1110 | IPC8 | 31:16 | — | — | — | — | — | — | RTCCIP<2:0> | RTCCIS<1:0> | — | — | — | — | — | — | — | FSCMIP<2:0> | FSCMIS<1:0> | 0000 | | | |
| | | 15:0 | — | — | — | — | — | — | I2C2IP<2:0> | I2C2IS<1:0> | — | — | — | — | — | — | — | U2IP<2:0> | U2IS<1:0> | 0000 | | | |
| 1120 | IPC9 | 31:16 | — | — | — | — | — | — | DMA3IP<2:0> | DMA3IS<1:0> | — | — | — | — | — | — | — | DMA2IP<2:0> | DMA2IS<1:0> | 0000 | | | |
| | | 15:0 | — | — | — | — | — | — | DMA1IP<2:0> | DMA1IS<1:0> | — | — | — | — | — | — | — | DMA0IP<2:0> | DMA0IS<1:0> | 0000 | | | |
| 1140 | IPC11 | 31:16 | — | — | — | — | — | — | — | — | — | — | — | — | — | — | — | — | — | 0000 | | | |
| | | 15:0 | — | — | — | — | — | — | — | — | — | — | — | — | — | — | — | — | — | — | 0000 | | |
| | | | USBIP<2:0> | | | | | | | | USBIS<1:0> | | | | FCEIP<2:0> | | | | FCEIS<1:0> | | | | 0000 |

Legend: x = unknown value on Reset, — = unimplemented, read as '0'. Reset values are shown in hexadecimal.

- Note 1:** Except where noted, all registers in this table have corresponding CLR, SET, and INV registers at their virtual addresses, plus offsets of 0x4, 0x8 and 0xC, respectively. See [Section 12.1.1 "CLR, SET and INV Registers"](#) for more information.
- 2:** This register does not have associated CLR, SET, and INV registers.

TABLE 4-3: INTERRUPT REGISTERS MAP FOR PIC32MX340F128H, PIC32MX340F256H, PIC32MX340F512H, PIC32MX340F128L, PIC32MX360F256L AND PIC32MX360F512L DEVICES ONLY⁽¹⁾

| Virtual Address (BF88_#) | Register Name | Bit Range | Bits | | | | | | | | | | | | | | | | All Resets |
|--------------------------|------------------------|-----------|-------------|---------|---------|-------------|---------|----------|-------------|------------|----------|----------|---------|-------------|------------|--------|-------------|------------|------------|
| | | | 31/15 | 30/14 | 29/13 | 28/12 | 27/11 | 26/10 | 25/9 | 24/8 | 23/7 | 22/6 | 21/5 | 20/4 | 19/3 | 18/2 | 17/1 | 16/0 | |
| 1000 | INTCON | 31:16 | — | — | — | — | — | — | — | — | — | — | — | — | — | — | — | SS0 | 0000 |
| | | 15:0 | — | — | — | MVEC | — | TPC<2:0> | | | — | — | — | — | INT4EP | INT3EP | INT2EP | INT1EP | INT0EP |
| 1010 | INTSTAT ⁽²⁾ | 31:16 | — | — | — | — | — | — | — | — | — | — | — | — | — | — | — | — | 0000 |
| | | 15:0 | — | — | — | — | — | — | — | SRIPL<2:0> | | | — | — | VEC<5:0> | | | — | — |
| 1020 | IPTMR | 31:16 | IPTMR<31:0> | | | | | | | | | | | | | | | | 0000 |
| | | 15:0 | | | | | | | | | | | | | | | | | 0000 |
| 1030 | IFS0 | 31:16 | I2C1MIF | I2C1SIF | I2C1BIF | U1TXIF | U1RXIF | U1EIF | SPI1RXIF | SPI1TXIF | SPI1EIF | OC5IF | IC5IF | T5IF | INT4IF | OC4IF | IC4IF | T4IF | 0000 |
| | | 15:0 | INT3IF | OC3IF | IC3IF | T3IF | INT2IF | OC2IF | IC2IF | T2IF | INT1IF | OC1IF | IC1IF | T1IF | INT0IF | CS1IF | CS0IF | CTIF | 0000 |
| 1040 | IFS1 | 31:16 | — | — | — | — | — | — | — | FCEIF | — | — | — | — | DMA3IF | DMA2IF | DMA1IF | DMA0IF | 0000 |
| | | 15:0 | RTCCIF | FSCMIF | I2C2MIF | I2C2SIF | I2C2BIF | U2TXIF | U2RXIF | U2EIF | SPI2RXIF | SPI2TXIF | SPI2EIF | CMP2IF | CMP1IF | PMP1IF | AD1IF | CNIF | 0000 |
| 1060 | IEC0 | 31:16 | I2C1MIE | I2C1SIE | I2C1BIE | U1TXIE | U1RXIE | U1EIE | SPI1RXIE | SPI1TXIE | SPI1EIE | OC5IE | IC5IE | T5IE | INT4IE | OC4IE | IC4IE | T4IE | 0000 |
| | | 15:0 | INT3IE | OC3IE | IC3IE | T3IE | INT2IE | OC2IE | IC2IE | T2IE | INT1IE | OC1IE | IC1IE | T1IE | INT0IE | CS1IE | CS0IE | CTIE | 0000 |
| 1070 | IEC1 | 31:16 | — | — | — | — | — | — | — | FCEIE | — | — | — | — | DMA3IE | DMA2IE | DMA1IE | DMA0IE | 0000 |
| | | 15:0 | RTCCIE | FSCMIE | I2C2MIE | — | — | — | — | — | SPI2RXIE | SPI2TXIE | SPI2EIE | CMP2IE | CMP1IE | PMP1IE | AD1IE | CNIE | 0000 |
| 1090 | IPC0 | 31:16 | — | — | — | INT0IP<2:0> | | | INT0IS<1:0> | | | — | — | CS1IP<2:0> | | | CS1IS<1:0> | | 0000 |
| | | 15:0 | — | — | — | CS0IP<2:0> | | | CS0IS<1:0> | | | — | — | CTIP<2:0> | | | CTIS<1:0> | | 0000 |
| 10A0 | IPC1 | 31:16 | — | — | — | INT1IP<2:0> | | | INT1IS<1:0> | | | — | — | OC1IP<2:0> | | | OC1IS<1:0> | | 0000 |
| | | 15:0 | — | — | — | IC1IP<2:0> | | | IC1IS<1:0> | | | — | — | T1IP<2:0> | | | T1IS<1:0> | | 0000 |
| 10B0 | IPC2 | 31:16 | — | — | — | INT2IP<2:0> | | | INT2IS<1:0> | | | — | — | OC2IP<2:0> | | | OC2IS<1:0> | | 0000 |
| | | 15:0 | — | — | — | IC2IP<2:0> | | | IC2IS<1:0> | | | — | — | T2IP<2:0> | | | T2IS<1:0> | | 0000 |
| 10C0 | IPC3 | 31:16 | — | — | — | INT3IP<2:0> | | | INT3IS<1:0> | | | — | — | OC3IP<2:0> | | | OC3IS<1:0> | | 0000 |
| | | 15:0 | — | — | — | IC3IP<2:0> | | | IC3IS<1:0> | | | — | — | T3IP<2:0> | | | T3IS<1:0> | | 0000 |
| 10D0 | IPC4 | 31:16 | — | — | — | INT4IP<2:0> | | | INT4IS<1:0> | | | — | — | OC4IP<2:0> | | | OC4IS<1:0> | | 0000 |
| | | 15:0 | — | — | — | IC4IP<2:0> | | | IC4IS<1:0> | | | — | — | T4IP<2:0> | | | T4IS<1:0> | | 0000 |
| 10E0 | IPC5 | 31:16 | — | — | — | SPI1IP<2:0> | | | SPI1IS<1:0> | | | — | — | OC5IP<2:0> | | | OC5IS<1:0> | | 0000 |
| | | 15:0 | — | — | — | IC5IP<2:0> | | | IC5IS<1:0> | | | — | — | T5IP<2:0> | | | T5IS<1:0> | | 0000 |
| 10F0 | IPC6 | 31:16 | — | — | — | AD1IP<2:0> | | | AD1IS<1:0> | | | — | — | CNIP<2:0> | | | CNIS<1:0> | | 0000 |
| | | 15:0 | — | — | — | I2C1IP<2:0> | | | I2C1IS<1:0> | | | — | — | U1IP<2:0> | | | U1IS<1:0> | | 0000 |
| 1100 | IPC7 | 31:16 | — | — | — | SPI2IP<2:0> | | | SPI2IS<1:0> | | | — | — | CMP2IP<2:0> | | | CMP2IS<1:0> | | 0000 |
| | | 15:0 | — | — | — | CMP1IP<2:0> | | | CMP1IS<1:0> | | | — | — | PMP1IP<2:0> | | | PMP1IS<1:0> | | 0000 |
| 1110 | IPC8 | 31:16 | — | — | — | RTCCIP<2:0> | | | RTCCIS<1:0> | | | — | — | FSCMIP<2:0> | | | FSCMIS<1:0> | | 0000 |
| | | 15:0 | — | — | — | I2C2IP<2:0> | | | I2C2IS<1:0> | | | — | — | U2IP<2:0> | | | U2IS<1:0> | | 0000 |
| 1120 | IPC9 | 31:16 | — | — | — | DMA3IP<2:0> | | | DMA3IS<1:0> | | | — | — | DMA2IP<2:0> | | | DMA2IS<1:0> | | 0000 |
| | | 15:0 | — | — | — | DMA1IP<2:0> | | | DMA1IS<1:0> | | | — | — | DMA0IP<2:0> | | | DMA0IS<1:0> | | 0000 |
| 1140 | IPC11 | 31:16 | — | — | — | — | — | — | — | — | — | — | — | — | — | — | — | — | 0000 |
| | | 15:0 | — | — | — | — | — | — | — | — | — | — | — | — | FCEIP<2:0> | | | FCEIS<1:0> | |

Legend: x = unknown value on Reset, — = unimplemented, read as '0'. Reset values are shown in hexadecimal.

Note 1: Except where noted, all registers in this table have corresponding CLR, SET and INV registers at their virtual addresses, plus offsets of 0x4, 0x8 and 0xC, respectively. See [Section 12.1.1 "CLR, SET and INV Registers"](#) for more information.

2: This register does not have associated CLR, SET, and INV registers.

TABLE 4-4: INTERRUPT REGISTERS MAP FOR PIC32MX320F032H, PIC32MX320F064H, PIC32MX320F128H AND PIC32MX320F128L DEVICES ONLY⁽¹⁾

| Virtual Address (BF88_#) | Register Name | Bit Range | Bits | | | | | | | | | | | | | | | | All Resets |
|-----------------------------|------------------------|-----------|-------------|---------|---------|---------|---------|--------|----------|----------|----------|----------|---------|--------|--------|--------|--------|--------|------------|
| | | | 31/15 | 30/14 | 29/13 | 28/12 | 27/11 | 26/10 | 25/9 | 24/8 | 23/7 | 22/6 | 21/5 | 20/4 | 19/3 | 18/2 | 17/1 | 16/0 | |
| 1000 | INTCON | 31:16 | — | — | — | — | — | — | — | — | — | — | — | — | — | — | — | SS0 | 0000 |
| | | 15:0 | — | — | — | MVEC | — | — | — | — | — | — | — | — | INT4EP | INT3EP | INT2EP | INT1EP | INT0EP |
| 1010 | INTSTAT ⁽²⁾ | 31:16 | — | — | — | — | — | — | — | — | — | — | — | — | — | — | — | — | 0000 |
| | | 15:0 | — | — | — | — | — | — | — | — | — | — | — | — | — | — | — | — | — |
| 1020 | IPTMR | 31:16 | IPTMR<31:0> | | | | | | | | | | | | | | | | 0000 |
| | | 15:0 | | | | | | | | | | | | | | | | | 0000 |
| 1030 | IFS0 | 31:16 | I2C1MIF | I2C1SIF | I2C1BIF | U1TXIF | U1RXIF | U1EIF | SPI1RXIF | SPI1TXIF | SPI1EIF | OC5IF | IC5IF | T5IF | INT4IF | OC4IF | IC4IF | T4IF | 0000 |
| | | 15:0 | INT3IF | OC3IF | IC3IF | T3IF | INT2IF | OC2IF | IC2IF | T2IF | INT1IF | OC1IF | IC1IF | T1IF | INT0IF | CS1IF | CS0IF | CTIF | 0000 |
| 1040 | IFS1 | 31:16 | — | — | — | — | — | — | — | FCEIF | — | — | — | — | — | — | — | — | 0000 |
| | | 15:0 | RTCCIF | FSCMIF | I2C2MIF | I2C2SIF | I2C2BIF | U2TXIF | U2RXIF | U2EIF | SPI2RXIF | SPI2TXIF | SPI2EIF | CMP2IF | CMP1IF | PMPIF | AD1IF | CNIF | 0000 |
| 1060 | IEC0 | 31:16 | I2C1MIE | I2C1SIE | I2C1BIE | U1TXIE | U1RXIE | U1EIE | SPI1RXIE | SPI1TXIE | SPI1EIE | OC5IE | IC5IE | T5IE | INT4IE | OC4IE | IC4IE | T4IE | 0000 |
| | | 15:0 | INT3IE | OC3IE | IC3IE | T3IE | INT2IE | OC2IE | IC2IE | T2IE | INT1IE | OC1IE | IC1IE | T1IE | INT0IE | CS1IE | CS0IE | CTIE | 0000 |
| 1070 | IEC1 | 31:16 | — | — | — | — | — | — | — | FCEIE | — | — | — | — | — | — | — | — | 0000 |
| | | 15:0 | RTCCIE | FSCMIE | I2C2MIE | — | — | — | — | — | SPI2RXIE | SPI2TXIE | SPI2EIE | CMP2IE | CMP1IE | PMPIE | AD1IE | CNIE | 0000 |
| 1090 | IPC0 | 31:16 | — | — | — | — | — | — | — | — | — | — | — | — | — | — | — | — | 0000 |
| | | 15:0 | — | — | — | — | — | — | — | — | — | — | — | — | — | — | — | — | — |
| 10A0 | IPC1 | 31:16 | — | — | — | — | — | — | — | — | — | — | — | — | — | — | — | — | 0000 |
| | | 15:0 | — | — | — | — | — | — | — | — | — | — | — | — | — | — | — | — | — |
| 10B0 | IPC2 | 31:16 | — | — | — | — | — | — | — | — | — | — | — | — | — | — | — | — | 0000 |
| | | 15:0 | — | — | — | — | — | — | — | — | — | — | — | — | — | — | — | — | — |
| 10C0 | IPC3 | 31:16 | — | — | — | — | — | — | — | — | — | — | — | — | — | — | — | — | 0000 |
| | | 15:0 | — | — | — | — | — | — | — | — | — | — | — | — | — | — | — | — | — |
| 10D0 | IPC4 | 31:16 | — | — | — | — | — | — | — | — | — | — | — | — | — | — | — | — | 0000 |
| | | 15:0 | — | — | — | — | — | — | — | — | — | — | — | — | — | — | — | — | — |
| 10E0 | IPC5 | 31:16 | — | — | — | — | — | — | — | — | — | — | — | — | — | — | — | — | 0000 |
| | | 15:0 | — | — | — | — | — | — | — | — | — | — | — | — | — | — | — | — | — |
| 10F0 | IPC6 | 31:16 | — | — | — | — | — | — | — | — | — | — | — | — | — | — | — | — | 0000 |
| | | 15:0 | — | — | — | — | — | — | — | — | — | — | — | — | — | — | — | — | — |
| 1100 | IPC7 | 31:16 | — | — | — | — | — | — | — | — | — | — | — | — | — | — | — | — | 0000 |
| | | 15:0 | — | — | — | — | — | — | — | — | — | — | — | — | — | — | — | — | — |
| 1110 | IPC8 | 31:16 | — | — | — | — | — | — | — | — | — | — | — | — | — | — | — | — | 0000 |
| | | 15:0 | — | — | — | — | — | — | — | — | — | — | — | — | — | — | — | — | — |
| 1140 | IPC11 | 31:16 | — | — | — | — | — | — | — | — | — | — | — | — | — | — | — | — | 0000 |
| | | 15:0 | — | — | — | — | — | — | — | — | — | — | — | — | — | — | — | — | — |

Legend: x = unknown value on Reset, — = unimplemented, read as '0'. Reset values are shown in hexadecimal.

Note 1: Except where noted, all registers in this table have corresponding CLR, SET and INV registers at their virtual addresses, plus offsets of 0x4, 0x8 and 0xC, respectively. See [Section 12.1.1 "CLR, SET and INV Registers"](#) for more information.

2: This register does not have associated CLR, SET, and INV registers.

TABLE 4-5: INTERRUPT REGISTERS MAP FOR PIC32MX440F128H, PIC32MX440F256H AND PIC32MX440F512H DEVICES ONLY⁽¹⁾

| Virtual Address (BF88_#) | Register Name | Bit Range | Bits | | | | | | | | | | | | | | | All Resets | |
|-----------------------------|------------------------|-----------|-------------|---------|---------|-------------|---------|----------|-------------|-------|----------|----------|---------|-------------|--------|--------|-------------|------------|----------|
| | | | 31/15 | 30/14 | 29/13 | 28/12 | 27/11 | 26/10 | 25/9 | 24/8 | 23/7 | 22/6 | 21/5 | 20/4 | 19/3 | 18/2 | 17/1 | | 16/0 |
| 1000 | INTCON | 31:16 | — | — | — | — | — | — | — | — | — | — | — | — | — | — | — | SS0 | 0000 |
| | | 15:0 | — | — | — | MVEC | — | TPC<2:0> | | | — | — | — | INT4EP | INT3EP | INT2EP | INT1EP | INT0EP | 0000 |
| 1010 | INTSTAT ⁽²⁾ | 31:16 | — | — | — | — | — | — | — | — | — | — | — | — | — | — | — | — | 0000 |
| | | 15:0 | — | — | — | — | — | — | — | — | — | — | — | — | — | — | — | — | VEC<5:0> |
| 1020 | IPTMR | 31:16 | IPTMR<31:0> | | | | | | | | | | | | | | | 0000 | |
| | | 15:0 | | | | | | | | | | | | | | | | 0000 | |
| 1030 | IFS0 | 31:16 | I2C1MIF | I2C1SIF | I2C1BIF | U1TXIF | U1RXIF | U1EIF | — | — | — | OC5IF | IC5IF | T5IF | INT4IF | OC4IF | IC4IF | T4IF | 0000 |
| | | 15:0 | INT3IF | OC3IF | IC3IF | T3IF | INT2IF | OC2IF | IC2IF | T2IF | INT1IF | OC1IF | IC1IF | T1IF | INT0IF | CS1IF | CS0IF | CTIF | 0000 |
| 1040 | IFS1 | 31:16 | — | — | — | — | — | — | USBIF | FCEIF | — | — | — | — | DMA3IF | DMA2IF | DMA1IF | DMA0IF | 0000 |
| | | 15:0 | RTCCIF | FSCMIF | I2C2MIF | I2C2SIF | I2C2BIF | U2TXIF | U2RXIF | U2EIF | SPI2RXIF | SPI2TXIF | SPI2EIF | CMP2IF | CMP1IF | PMPIF | AD1IF | CNIF | 0000 |
| 1060 | IEC0 | 31:16 | I2C1MIE | I2C1SIE | I2C1BIE | U1TXIE | U1RXIE | U1EIE | — | — | — | OC5IE | IC5IE | T5IE | INT4IE | OC4IE | IC4IE | T4IE | 0000 |
| | | 15:0 | INT3IE | OC3IE | IC3IE | T3IE | INT2IE | OC2IE | IC2IE | T2IE | INT1IE | OC1IE | IC1IE | T1IE | INT0IE | CS1IE | CS0IE | CTIE | 0000 |
| 1070 | IEC1 | 31:16 | — | — | — | — | — | — | USBIE | FCEIE | — | — | — | — | DMA3IE | DMA2IE | DMA1IE | DMA0IE | 0000 |
| | | 15:0 | RTCCIE | FSCMIE | I2C2MIE | I2C2SIE | I2C2BIE | U2TXIE | U2RXIE | U2EIE | SPI2RXIE | SPI2TXIE | SPI2EIE | CMP2IE | CMP1IE | PMPIE | AD1IE | CNIE | 0000 |
| 1090 | IPC0 | 31:16 | — | — | — | INT0IP<2:0> | | | INT0IS<1:0> | | | — | — | CS1IP<2:0> | | | CS1IS<1:0> | | 0000 |
| | | 15:0 | — | — | — | CS0IP<2:0> | | | CS0IS<1:0> | | | — | — | CTIP<2:0> | | | CTIS<1:0> | | 0000 |
| 10A0 | IPC1 | 31:16 | — | — | — | INT1IP<2:0> | | | INT1IS<1:0> | | | — | — | OC1IP<2:0> | | | OC1IS<1:0> | | 0000 |
| | | 15:0 | — | — | — | IC1IP<2:0> | | | IC1IS<1:0> | | | — | — | T1IP<2:0> | | | T1IS<1:0> | | 0000 |
| 10B0 | IPC2 | 31:16 | — | — | — | INT2IP<2:0> | | | INT2IS<1:0> | | | — | — | OC2IP<2:0> | | | OC2IS<1:0> | | 0000 |
| | | 15:0 | — | — | — | IC2IP<2:0> | | | IC2IS<1:0> | | | — | — | T2IP<2:0> | | | T2IS<1:0> | | 0000 |
| 10C0 | IPC3 | 31:16 | — | — | — | INT3IP<2:0> | | | INT3IS<1:0> | | | — | — | OC3IP<2:0> | | | OC3IS<1:0> | | 0000 |
| | | 15:0 | — | — | — | IC3IP<2:0> | | | IC3IS<1:0> | | | — | — | T3IP<2:0> | | | T3IS<1:0> | | 0000 |
| 10D0 | IPC4 | 31:16 | — | — | — | INT4IP<2:0> | | | INT4IS<1:0> | | | — | — | OC4IP<2:0> | | | OC4IS<1:0> | | 0000 |
| | | 15:0 | — | — | — | IC4IP<2:0> | | | IC4IS<1:0> | | | — | — | T4IP<2:0> | | | T4IS<1:0> | | 0000 |
| 10E0 | IPC5 | 31:16 | — | — | — | — | — | — | — | — | — | — | — | OC5IP<2:0> | | | OC5IS<1:0> | | 0000 |
| | | 15:0 | — | — | — | IC5IP<2:0> | | | IC5IS<1:0> | | | — | — | T5IP<2:0> | | | T5IS<1:0> | | 0000 |
| 10F0 | IPC6 | 31:16 | — | — | — | AD1IP<2:0> | | | AD1IS<1:0> | | | — | — | CNIP<2:0> | | | CNIS<1:0> | | 0000 |
| | | 15:0 | — | — | — | I2C1IP<2:0> | | | I2C1IS<1:0> | | | — | — | U1IP<2:0> | | | U1IS<1:0> | | 0000 |
| 1100 | IPC7 | 31:16 | — | — | — | SPI2IP<2:0> | | | SPI2IS<1:0> | | | — | — | CMP2IP<2:0> | | | CMP2IS<1:0> | | 0000 |
| | | 15:0 | — | — | — | CMP1IP<2:0> | | | CMP1IS<1:0> | | | — | — | PMPIP<2:0> | | | PMPIS<1:0> | | 0000 |
| 1110 | IPC8 | 31:16 | — | — | — | RTCCIP<2:0> | | | RTCCIS<1:0> | | | — | — | FSCMIP<2:0> | | | FSCMIS<1:0> | | 0000 |
| | | 15:0 | — | — | — | I2C2IP<2:0> | | | I2C2IS<1:0> | | | — | — | U2IP<2:0> | | | U2IS<1:0> | | 0000 |
| 1120 | IPC9 | 31:16 | — | — | — | DMA3IP<2:0> | | | DMA3IS<1:0> | | | — | — | DMA2IP<2:0> | | | DMA2IS<1:0> | | 0000 |
| | | 15:0 | — | — | — | DMA1IP<2:0> | | | DMA1IS<1:0> | | | — | — | DMA0IP<2:0> | | | DMA0IS<1:0> | | 0000 |
| 1140 | IPC11 | 31:16 | — | — | — | — | — | — | — | — | — | — | — | — | — | — | — | — | 0000 |
| | | 15:0 | — | — | — | USBIP<2:0> | | | USBIS<1:0> | | | — | — | FCEIP<2:0> | | | FCEIS<1:0> | | 0000 |

Legend: x = unknown value on Reset, — = unimplemented, read as '0'. Reset values are shown in hexadecimal.

Note 1: Except where noted, all registers in this table have corresponding CLR, SET, and INV registers at their virtual addresses, plus offsets of 0x4, 0x8, and 0xC, respectively. See [Section 12.1.1 "CLR, SET and INV Registers"](#) for more information.

2: This register does not have associated CLR, SET, and INV registers.

TABLE 4-6: INTERRUPT REGISTERS MAP FOR THE PIC32MX420F032H DEVICE ONLY⁽¹⁾

| Virtual Address (BF88_#) | Register Name | Bit Range | Bits | | | | | | | | | | | | | | | | All Resets |
|-----------------------------|------------------------|-----------|-------------|---------|---------|---------|---------|--------|--------|-------|----------|----------|---------|--------|--------|--------|--------|--------|------------|
| | | | 31/15 | 30/14 | 29/13 | 28/12 | 27/11 | 26/10 | 25/9 | 24/8 | 23/7 | 22/6 | 21/5 | 20/4 | 19/3 | 18/2 | 17/1 | 16/0 | |
| 1000 | INTCON | 31:16 | — | — | — | — | — | — | — | — | — | — | — | — | — | — | — | SS0 | 0000 |
| | | 15:0 | — | — | — | MVEC | — | — | — | — | — | — | — | — | INT4EP | INT3EP | INT2EP | INT1EP | INT0EP |
| 1010 | INTSTAT ⁽²⁾ | 31:16 | — | — | — | — | — | — | — | — | — | — | — | — | — | — | — | — | 0000 |
| | | 15:0 | — | — | — | — | — | — | — | — | — | — | — | — | — | — | — | — | — |
| 1020 | IPTMR | 31:16 | IPTMR<31:0> | | | | | | | | | | | | | | | | 0000 |
| | | 15:0 | | | | | | | | | | | | | | | | | 0000 |
| 1030 | IFS0 | 31:16 | I2C1MIF | I2C1SIF | I2C1BIF | U1TXIF | U1RXIF | U1EIF | — | — | — | OC5IF | IC5IF | T5IF | INT4IF | OC4IF | IC4IF | T4IF | 0000 |
| | | 15:0 | INT3IF | OC3IF | IC3IF | T3IF | INT2IF | OC2IF | IC2IF | T2IF | INT1IF | OC1IF | IC1IF | T1IF | INT0IF | CS1IF | CS0IF | CTIF | 0000 |
| 1040 | IFS1 | 31:16 | — | — | — | — | — | — | USBIF | FCEIF | — | — | — | — | — | — | — | — | 0000 |
| | | 15:0 | RTCCIF | FSCMIF | I2C2MIF | I2C2SIF | I2C2BIF | U2TXIF | U2RXIF | U2EIF | SPI2RXIF | SPI2TXIF | SPI2EIF | CMP2IF | CMP1IF | PMPIF | AD1IF | CNIF | 0000 |
| 1060 | IEC0 | 31:16 | I2C1MIE | I2C1SIE | I2C1BIE | U1TXIE | U1RXIE | U1EIE | — | — | — | OC5IE | IC5IE | T5IE | INT4IE | OC4IE | IC4IE | T4IE | 0000 |
| | | 15:0 | INT3IE | OC3IE | IC3IE | T3IE | INT2IE | OC2IE | IC2IE | T2IE | INT1IE | OC1IE | IC1IE | T1IE | INT0IE | CS1IE | CS0IE | CTIE | 0000 |
| 1070 | IEC1 | 31:16 | — | — | — | — | — | — | USBIE | FCEIE | — | — | — | — | — | — | — | — | 0000 |
| | | 15:0 | RTCCIE | FSCMIE | I2C2MIE | I2C2SIE | I2C2BIE | U2TXIE | U2RXIE | U2EIE | SPI2RXIE | SPI2TXIE | SPI2EIE | CMP2IE | CMP1IE | PMPIE | AD1IE | CNIE | 0000 |
| 1090 | IPC0 | 31:16 | — | — | — | — | — | — | — | — | — | — | — | — | — | — | — | — | 0000 |
| | | 15:0 | — | — | — | — | — | — | — | — | — | — | — | — | — | — | — | — | — |
| 10A0 | IPC1 | 31:16 | — | — | — | — | — | — | — | — | — | — | — | — | — | — | — | — | 0000 |
| | | 15:0 | — | — | — | — | — | — | — | — | — | — | — | — | — | — | — | — | — |
| 10B0 | IPC2 | 31:16 | — | — | — | — | — | — | — | — | — | — | — | — | — | — | — | — | 0000 |
| | | 15:0 | — | — | — | — | — | — | — | — | — | — | — | — | — | — | — | — | — |
| 10C0 | IPC3 | 31:16 | — | — | — | — | — | — | — | — | — | — | — | — | — | — | — | — | 0000 |
| | | 15:0 | — | — | — | — | — | — | — | — | — | — | — | — | — | — | — | — | — |
| 10D0 | IPC4 | 31:16 | — | — | — | — | — | — | — | — | — | — | — | — | — | — | — | — | 0000 |
| | | 15:0 | — | — | — | — | — | — | — | — | — | — | — | — | — | — | — | — | — |
| 10E0 | IPC5 | 31:16 | — | — | — | — | — | — | — | — | — | — | — | — | — | — | — | — | 0000 |
| | | 15:0 | — | — | — | — | — | — | — | — | — | — | — | — | — | — | — | — | — |
| 10F0 | IPC6 | 31:16 | — | — | — | — | — | — | — | — | — | — | — | — | — | — | — | — | 0000 |
| | | 15:0 | — | — | — | — | — | — | — | — | — | — | — | — | — | — | — | — | — |
| 1100 | IPC7 | 31:16 | — | — | — | — | — | — | — | — | — | — | — | — | — | — | — | — | 0000 |
| | | 15:0 | — | — | — | — | — | — | — | — | — | — | — | — | — | — | — | — | — |
| 1110 | IPC8 | 31:16 | — | — | — | — | — | — | — | — | — | — | — | — | — | — | — | — | 0000 |
| | | 15:0 | — | — | — | — | — | — | — | — | — | — | — | — | — | — | — | — | — |
| 1140 | IPC11 | 31:16 | — | — | — | — | — | — | — | — | — | — | — | — | — | — | — | — | 0000 |
| | | 15:0 | — | — | — | — | — | — | — | — | — | — | — | — | — | — | — | — | — |

Legend: x = unknown value on Reset, — = unimplemented, read as '0'. Reset values are shown in hexadecimal.

- Note 1:** Except where noted, all registers in this table have corresponding CLR, SET and INV registers at their virtual addresses, plus offsets of 0x4, 0x8 and 0xC, respectively. See [Section 12.1.1 "CLR, SET and INV Registers"](#) for more information.
- 2:** This register does not have associated CLR, SET, and INV registers.

TABLE 4-7: TIMER1-5 REGISTERS MAP⁽¹⁾

| Virtual Address (BF80_#) | Register Name | Bit Range | Bits | | | | | | | | | | | | | | | | All Resets |
|-----------------------------|------------------|-----------|------------|-------|-------|-------|-------|-------|------|------|-------|------|------------|------|------|------|------|--------------------|------------|
| | | | 31/15 | 30/14 | 29/13 | 28/12 | 27/11 | 26/10 | 25/9 | 24/8 | 23/7 | 22/6 | 21/5 | 20/4 | 19/3 | 18/2 | 17/1 | 16/0 | |
| 0600 | T1CON | 31:16 | — | — | — | — | — | — | — | — | — | — | — | — | — | — | — | — | 0000 |
| | | 15:0 | ON | — | SIDL | TWDIS | TWIP | — | — | — | TGATE | — | TCKPS<1:0> | — | — | — | — | — | 0000 |
| 0610 | TMR1 | 31:16 | — | — | — | — | — | — | — | — | — | — | — | — | — | — | — | — | 0000 |
| | | 15:0 | TMR1<15:0> | | | | | | | | | | | | | | | | 0000 |
| 0620 | PR1 | 31:16 | — | — | — | — | — | — | — | — | — | — | — | — | — | — | — | — | 0000 |
| | | 15:0 | PR1<15:0> | | | | | | | | | | | | | | | | FFFF |
| 0800 | T2CON | 31:16 | — | — | — | — | — | — | — | — | — | — | — | — | — | — | — | — | 0000 |
| | | 15:0 | ON | — | SIDL | — | — | — | — | — | TGATE | — | TCKPS<2:0> | — | — | T32 | — | TCS ⁽²⁾ | — |
| 0810 | TMR2 | 31:16 | — | — | — | — | — | — | — | — | — | — | — | — | — | — | — | — | 0000 |
| | | 15:0 | TMR2<15:0> | | | | | | | | | | | | | | | | 0000 |
| 0820 | PR2 | 31:16 | — | — | — | — | — | — | — | — | — | — | — | — | — | — | — | — | 0000 |
| | | 15:0 | PR2<15:0> | | | | | | | | | | | | | | | | FFFF |
| 0A00 | T3CON | 31:16 | — | — | — | — | — | — | — | — | — | — | — | — | — | — | — | — | 0000 |
| | | 15:0 | ON | — | SIDL | — | — | — | — | — | TGATE | — | TCKPS<2:0> | — | — | — | — | TCS ⁽²⁾ | — |
| 0A10 | TMR3 | 31:16 | — | — | — | — | — | — | — | — | — | — | — | — | — | — | — | — | 0000 |
| | | 15:0 | TMR3<15:0> | | | | | | | | | | | | | | | | 0000 |
| 0A20 | PR3 | 31:16 | — | — | — | — | — | — | — | — | — | — | — | — | — | — | — | — | 0000 |
| | | 15:0 | PR3<15:0> | | | | | | | | | | | | | | | | FFFF |
| 0C00 | T4CON | 31:16 | — | — | — | — | — | — | — | — | — | — | — | — | — | — | — | — | 0000 |
| | | 15:0 | ON | — | SIDL | — | — | — | — | — | TGATE | — | TCKPS<2:0> | — | — | T32 | — | TCS ⁽²⁾ | — |
| 0C10 | TMR4 | 31:16 | — | — | — | — | — | — | — | — | — | — | — | — | — | — | — | — | 0000 |
| | | 15:0 | TMR4<15:0> | | | | | | | | | | | | | | | | 0000 |
| 0C20 | PR4 | 31:16 | — | — | — | — | — | — | — | — | — | — | — | — | — | — | — | — | 0000 |
| | | 15:0 | PR4<15:0> | | | | | | | | | | | | | | | | FFFF |
| 0E00 | T5CON | 31:16 | — | — | — | — | — | — | — | — | — | — | — | — | — | — | — | — | 0000 |
| | | 15:0 | ON | — | SIDL | — | — | — | — | — | TGATE | — | TCKPS<2:0> | — | — | — | — | TCS ⁽²⁾ | — |
| 0E10 | TMR5 | 31:16 | — | — | — | — | — | — | — | — | — | — | — | — | — | — | — | — | 0000 |
| | | 15:0 | TMR5<15:0> | | | | | | | | | | | | | | | | 0000 |
| 0E20 | PR5 | 31:16 | — | — | — | — | — | — | — | — | — | — | — | — | — | — | — | — | 0000 |
| | | 15:0 | PR5<15:0> | | | | | | | | | | | | | | | | FFFF |

Legend: x = unknown value on Reset, — = unimplemented, read as '0'. Reset values are shown in hexadecimal.

- Note 1:** All registers in this table have corresponding CLR, SET and INV registers at their virtual addresses, plus offsets of 0x4, 0x8 and 0xC, respectively. See [Section 12.1.1 “CLR, SET and INV Registers”](#) for more information.
- Note 2:** This bit is not available on 64-pin devices.

TABLE 4-8: INPUT CAPTURE1-5 REGISTERS MAP

| Virtual Address (BF80_#) | Register Name | Bit Range | Bits | | | | | | | | | | | | | | All Resets | | |
|-----------------------------|-----------------------|-----------|--------------|-------|-------|-------|-------|-------|-------|------|-------|----------|------|-------|----------|------|------------|------|------|
| | | | 31/15 | 30/14 | 29/13 | 28/12 | 27/11 | 26/10 | 25/9 | 24/8 | 23/7 | 22/6 | 21/5 | 20/4 | 19/3 | 18/2 | | 17/1 | 16/0 |
| 2000 | IC1CON ⁽¹⁾ | 31:16 | — | — | — | — | — | — | — | — | — | — | — | — | — | — | — | — | 0000 |
| | | 15:0 | ON | — | SIDL | — | — | — | FEDGE | C32 | ICTMR | ICI<1:0> | ICOV | ICBNE | ICM<2:0> | — | — | — | 0000 |
| 2010 | IC1BUF | 31:16 | IC1BUF<31:0> | | | | | | | | | | | | | | xxxx | | |
| | | 15:0 | | | | | | | | | | | | | | | xxxx | | |
| 2200 | IC2CON ⁽¹⁾ | 31:16 | — | — | — | — | — | — | — | — | — | — | — | — | — | — | — | — | 0000 |
| | | 15:0 | ON | — | SIDL | — | — | — | FEDGE | C32 | ICTMR | ICI<1:0> | ICOV | ICBNE | ICM<2:0> | — | — | — | 0000 |
| 2210 | IC2BUF | 31:16 | IC2BUF<31:0> | | | | | | | | | | | | | | xxxx | | |
| | | 15:0 | | | | | | | | | | | | | | | xxxx | | |
| 2400 | IC3CON ⁽¹⁾ | 31:16 | — | — | — | — | — | — | — | — | — | — | — | — | — | — | — | — | 0000 |
| | | 15:0 | ON | — | SIDL | — | — | — | FEDGE | C32 | ICTMR | ICI<1:0> | ICOV | ICBNE | ICM<2:0> | — | — | — | 0000 |
| 2410 | IC3BUF | 31:16 | IC3BUF<31:0> | | | | | | | | | | | | | | xxxx | | |
| | | 15:0 | | | | | | | | | | | | | | | xxxx | | |
| 2600 | IC4CON ⁽¹⁾ | 31:16 | — | — | — | — | — | — | — | — | — | — | — | — | — | — | — | — | 0000 |
| | | 15:0 | ON | — | SIDL | — | — | — | FEDGE | C32 | ICTMR | ICI<1:0> | ICOV | ICBNE | ICM<2:0> | — | — | — | 0000 |
| 2610 | IC4BUF | 31:16 | IC4BUF<31:0> | | | | | | | | | | | | | | xxxx | | |
| | | 15:0 | | | | | | | | | | | | | | | xxxx | | |
| 2800 | IC5CON ⁽¹⁾ | 31:16 | — | — | — | — | — | — | — | — | — | — | — | — | — | — | — | — | 0000 |
| | | 15:0 | ON | — | SIDL | — | — | — | FEDGE | C32 | ICTMR | ICI<1:0> | ICOV | ICBNE | ICM<2:0> | — | — | — | 0000 |
| 2810 | IC5BUF | 31:16 | IC5BUF<31:0> | | | | | | | | | | | | | | xxxx | | |
| | | 15:0 | | | | | | | | | | | | | | | xxxx | | |

Legend: x = unknown value on Reset, — = unimplemented, read as '0'. Reset values are shown in hexadecimal.

Note 1: This register has corresponding CLR, SET and INV registers at its virtual address, plus an offset of 0x4, 0x8 and 0xC, respectively. See [Section 12.1.1 “CLR, SET and INV Registers”](#) for more information.

TABLE 4-9: OUTPUT COMPARE1-5 REGISTERS MAP⁽¹⁾

| Virtual Address (BF80_#) | Register Name | Bit Range | Bits | | | | | | | | | | | | | | | | All Resets |
|-----------------------------|------------------|-----------|-------------|-------|-------|-------|-------|-------|------|------|------|------|------|-------|--------|----------|------|------|------------|
| | | | 31/15 | 30/14 | 29/13 | 28/12 | 27/11 | 26/10 | 25/9 | 24/8 | 23/7 | 22/6 | 21/5 | 20/4 | 19/3 | 18/2 | 17/1 | 16/0 | |
| 3000 | OC1CON | 31:16 | — | — | — | — | — | — | — | — | — | — | — | — | — | — | — | — | 0000 |
| | | 15:0 | ON | — | SIDL | — | — | — | — | — | — | — | OC32 | OCFLT | OCTSEL | OCM<2:0> | | | 0000 |
| 3010 | OC1R | 31:16 | OC1R<31:0> | | | | | | | | | | | | | | | | xxxx |
| | | 15:0 | | | | | | | | | | | | | | | | | xxxx |
| 3020 | OC1RS | 31:16 | OC1RS<31:0> | | | | | | | | | | | | | | | | xxxx |
| | | 15:0 | | | | | | | | | | | | | | | | | xxxx |
| 3200 | OC2CON | 31:16 | — | — | — | — | — | — | — | — | — | — | — | — | — | — | — | — | 0000 |
| | | 15:0 | ON | — | SIDL | — | — | — | — | — | — | — | OC32 | OCFLT | OCTSEL | OCM<2:0> | | | 0000 |
| 3210 | OC2R | 31:16 | OC2R<31:0> | | | | | | | | | | | | | | | | xxxx |
| | | 15:0 | | | | | | | | | | | | | | | | | xxxx |
| 3220 | OC2RS | 31:16 | OC2RS<31:0> | | | | | | | | | | | | | | | | xxxx |
| | | 15:0 | | | | | | | | | | | | | | | | | xxxx |
| 3400 | OC3CON | 31:16 | — | — | — | — | — | — | — | — | — | — | — | — | — | — | — | — | 0000 |
| | | 15:0 | ON | — | SIDL | — | — | — | — | — | — | — | OC32 | OCFLT | OCTSEL | OCM<2:0> | | | 0000 |
| 3410 | OC3R | 31:16 | OC3R<31:0> | | | | | | | | | | | | | | | | xxxx |
| | | 15:0 | | | | | | | | | | | | | | | | | xxxx |
| 3420 | OC3RS | 31:16 | OC3RS<31:0> | | | | | | | | | | | | | | | | xxxx |
| | | 15:0 | | | | | | | | | | | | | | | | | xxxx |
| 3600 | OC4CON | 31:16 | — | — | — | — | — | — | — | — | — | — | — | — | — | — | — | — | 0000 |
| | | 15:0 | ON | — | SIDL | — | — | — | — | — | — | — | OC32 | OCFLT | OCTSEL | OCM<2:0> | | | 0000 |
| 3610 | OC4R | 31:16 | OC4R<31:0> | | | | | | | | | | | | | | | | xxxx |
| | | 15:0 | | | | | | | | | | | | | | | | | xxxx |
| 3620 | OC4RS | 31:16 | OC4RS<31:0> | | | | | | | | | | | | | | | | xxxx |
| | | 15:0 | | | | | | | | | | | | | | | | | xxxx |
| 3800 | OC5CON | 31:16 | — | — | — | — | — | — | — | — | — | — | — | — | — | — | — | — | 0000 |
| | | 15:0 | ON | — | SIDL | — | — | — | — | — | — | — | OC32 | OCFLT | OCTSEL | OCM<2:0> | | | 0000 |
| 3810 | OC5R | 31:16 | OC5R<31:0> | | | | | | | | | | | | | | | | xxxx |
| | | 15:0 | | | | | | | | | | | | | | | | | xxxx |
| 3820 | OC5RS | 31:16 | OC5RS<31:0> | | | | | | | | | | | | | | | | xxxx |
| | | 15:0 | | | | | | | | | | | | | | | | | xxxx |

Legend: x = unknown value on Reset, — = unimplemented, read as '0'. Reset values are shown in hexadecimal.

Note 1: All registers in this table have corresponding CLR, SET and INV registers at their virtual addresses, plus offsets of 0x4, 0x8 and 0xC, respectively. See [Section 12.1.1 “CLR, SET and INV Registers”](#) for more information.

TABLE 4-10: I2C1-2 REGISTERS MAP⁽¹⁾

| Virtual Address (BF80_#) | Register Name | Bit Range | Bits | | | | | | | | | | | | | | | All Resets | |
|-----------------------------|------------------|-----------|---------|--------|-------|--------|--------|-------|--------|--------|-------|-------|-------|-------|------|------|------|------------|------|
| | | | 31/15 | 30/14 | 29/13 | 28/12 | 27/11 | 26/10 | 25/9 | 24/8 | 23/7 | 22/6 | 21/5 | 20/4 | 19/3 | 18/2 | 17/1 | | 16/0 |
| 5000 | I2C1CON | 31:16 | — | — | — | — | — | — | — | — | — | — | — | — | — | — | — | — | 0000 |
| | | 15:0 | ON | — | SIDL | SCLREL | STRICT | A10M | DISSLW | SMEN | GCEN | STREN | ACKDT | ACKEN | RCEN | PEN | RSEN | SEN | 1000 |
| 5010 | I2C1STAT | 31:16 | — | — | — | — | — | — | — | — | — | — | — | — | — | — | — | — | 0000 |
| | | 15:0 | ACKSTAT | TRSTAT | — | — | — | — | BCL | GCSTAT | ADD10 | IWCOL | I2COV | D/A | P | S | R/W | RBF | TBF |
| 5020 | I2C1ADD | 31:16 | — | — | — | — | — | — | — | — | — | — | — | — | — | — | — | — | 0000 |
| | | 15:0 | — | — | — | — | — | — | — | — | — | — | — | — | — | — | — | — | — |
| 5030 | I2C1MSK | 31:16 | — | — | — | — | — | — | — | — | — | — | — | — | — | — | — | — | 0000 |
| | | 15:0 | — | — | — | — | — | — | — | — | — | — | — | — | — | — | — | — | — |
| 5040 | I2C1BRG | 31:16 | — | — | — | — | — | — | — | — | — | — | — | — | — | — | — | — | 0000 |
| | | 15:0 | — | — | — | — | — | — | — | — | — | — | — | — | — | — | — | — | — |
| 5050 | I2C1TRN | 31:16 | — | — | — | — | — | — | — | — | — | — | — | — | — | — | — | — | 0000 |
| | | 15:0 | — | — | — | — | — | — | — | — | — | — | — | — | — | — | — | — | — |
| 5260 | I2C1RCV | 31:16 | — | — | — | — | — | — | — | — | — | — | — | — | — | — | — | — | 0000 |
| | | 15:0 | — | — | — | — | — | — | — | — | — | — | — | — | — | — | — | — | — |
| 5200 | I2C2CON | 31:16 | — | — | — | — | — | — | — | — | — | — | — | — | — | — | — | — | 0000 |
| | | 15:0 | ON | — | SIDL | SCLREL | STRICT | A10M | DISSLW | SMEN | GCEN | STREN | ACKDT | ACKEN | RCEN | PEN | RSEN | SEN | 1000 |
| 5210 | I2C2STAT | 31:16 | — | — | — | — | — | — | — | — | — | — | — | — | — | — | — | — | 0000 |
| | | 15:0 | ACKSTAT | TRSTAT | — | — | — | — | BCL | GCSTAT | ADD10 | IWCOL | I2COV | D/A | P | S | R/W | RBF | TBF |
| 5220 | I2C2ADD | 31:16 | — | — | — | — | — | — | — | — | — | — | — | — | — | — | — | — | 0000 |
| | | 15:0 | — | — | — | — | — | — | — | — | — | — | — | — | — | — | — | — | — |
| 5230 | I2C2MSK | 31:16 | — | — | — | — | — | — | — | — | — | — | — | — | — | — | — | — | 0000 |
| | | 15:0 | — | — | — | — | — | — | — | — | — | — | — | — | — | — | — | — | — |
| 5240 | I2C2BRG | 31:16 | — | — | — | — | — | — | — | — | — | — | — | — | — | — | — | — | 0000 |
| | | 15:0 | — | — | — | — | — | — | — | — | — | — | — | — | — | — | — | — | — |
| 5250 | I2C2TRN | 31:16 | — | — | — | — | — | — | — | — | — | — | — | — | — | — | — | — | 0000 |
| | | 15:0 | — | — | — | — | — | — | — | — | — | — | — | — | — | — | — | — | — |
| 5260 | I2C2RCV | 31:16 | — | — | — | — | — | — | — | — | — | — | — | — | — | — | — | — | 0000 |
| | | 15:0 | — | — | — | — | — | — | — | — | — | — | — | — | — | — | — | — | — |

Legend: x = unknown value on Reset, — = unimplemented, read as '0'. Reset values are shown in hexadecimal.

Note 1: All registers in this table except I2CxRCV have corresponding CLR, SET and INV registers at their virtual addresses, plus offsets of 0x4, 0x8 and 0xC, respectively. See [Section 12.1.1 "CLR, SET and INV Registers"](#) for more information.

TABLE 4-11: UART1-2 REGISTERS MAP

| Virtual Address (BF80_#) | Register Name | Bit Range | Bits | | | | | | | | | | | | | | | All Resets |
|-----------------------------|-----------------------|-----------|--------------|--------|-------|--------|-------|-------|----------|-------------------|--------|-------|-------|------|------------|-------|------|------------|
| | | | 31/15 | 30/14 | 29/13 | 28/12 | 27/11 | 26/10 | 25/9 | 24/8 | 23/7 | 22/6 | 21/5 | 20/4 | 19/3 | 18/2 | 17/1 | |
| 6000 | U1MODE ⁽¹⁾ | 31:16 | — | — | — | — | — | — | — | — | — | — | — | — | — | — | — | 0000 |
| | | 15:0 | ON | — | SIDL | IREN | RTSMO | — | UEN<1:0> | WAKE | LPBACK | ABAUO | RXINV | BRGH | PDSEL<1:0> | STSEL | 0000 | |
| 6010 | U1STA ⁽¹⁾ | 31:16 | — | — | — | — | — | — | ADM_EN | ADDR<7:0> | | | | | | | | 0000 |
| | | 15:0 | UTXISEL<1:0> | UTXINV | URXEN | UTXBRK | UTXEN | UTXBF | TRMT | URXISEL<1:0> | ADDEN | RIDLE | PERR | FERR | OERR | URXDA | 0110 | |
| 6020 | U1TXREG | 31:16 | — | — | — | — | — | — | — | — | — | — | — | — | — | — | 0000 | |
| | | 15:0 | — | — | — | — | — | — | TX8 | Transmit Register | | | | | | | | 0000 |
| 6030 | U1RXREG | 31:16 | — | — | — | — | — | — | — | — | — | — | — | — | — | — | 0000 | |
| | | 15:0 | — | — | — | — | — | — | RX8 | Receive Register | | | | | | | | 0000 |
| 6040 | U1BRG ⁽¹⁾ | 31:16 | — | — | — | — | — | — | — | — | — | — | — | — | — | — | 0000 | |
| | | 15:0 | BRG<15:0> | | | | | | | | | | | | | | | 0000 |
| 6200 | U2MODE ⁽¹⁾ | 31:16 | — | — | — | — | — | — | — | — | — | — | — | — | — | — | 0000 | |
| | | 15:0 | ON | — | SIDL | IREN | RTSMO | — | UEN<1:0> | WAKE | LPBACK | ABAUO | RXINV | BRGH | PDSEL<1:0> | STSEL | 0000 | |
| 6210 | U2STA ⁽¹⁾ | 31:16 | — | — | — | — | — | — | ADM_EN | ADDR<7:0> | | | | | | | | 0000 |
| | | 15:0 | UTXISEL<1:0> | UTXINV | URXEN | UTXBRK | UTXEN | UTXBF | TRMT | URXISEL<1:0> | ADDEN | RIDLE | PERR | FERR | OERR | URXDA | 0110 | |
| 6220 | U2TXREG | 31:16 | — | — | — | — | — | — | — | — | — | — | — | — | — | — | 0000 | |
| | | 15:0 | — | — | — | — | — | — | TX8 | Transmit Register | | | | | | | | 0000 |
| 6230 | U2RXREG | 31:16 | — | — | — | — | — | — | — | — | — | — | — | — | — | — | 0000 | |
| | | 15:0 | — | — | — | — | — | — | RX8 | Receive Register | | | | | | | | 0000 |
| 6240 | U2BRG ⁽¹⁾ | 31:16 | — | — | — | — | — | — | — | — | — | — | — | — | — | — | 0000 | |
| | | 15:0 | BRG<15:0> | | | | | | | | | | | | | | | 0000 |

Legend: x = unknown value on Reset, — = unimplemented, read as '0'. Reset values are shown in hexadecimal.

Note 1: This register has corresponding CLR, SET and INV registers at its virtual address, plus an offset of 0x4, 0x8 and 0xC, respectively. See [Section 12.1.1 “CLR, SET and INV Registers”](#) for more information.

TABLE 4-12: SPI1-2 REGISTERS MAP^(1,2)

| Virtual Address (BF80_#) | Register Name | Bit Range | Bits | | | | | | | | | | | | | | | All Resets | | |
|-----------------------------|------------------|-----------|------------|---------|--------|--------|---------|--------|------|----------|------|--------|-------|------|--------|------|-------|------------|--------|------|
| | | | 31/15 | 30/14 | 29/13 | 28/12 | 27/11 | 26/10 | 25/9 | 24/8 | 23/7 | 22/6 | 21/5 | 20/4 | 19/3 | 18/2 | 17/1 | | 16/0 | |
| 5800 | SPI1CON | 31:16 | FRMEN | FRMSYNC | FRMPOL | — | — | — | — | — | — | — | — | — | — | — | SPIFE | — | 0000 | |
| | | 15:0 | ON | — | SIDL | DISSDO | MODE32 | MODE16 | SMP | CKE | SSEN | CKP | MSTEN | — | — | — | — | — | — | 0000 |
| 5810 | SPI1STAT | 31:16 | — | — | — | — | — | — | — | — | — | — | — | — | — | — | — | — | 0000 | |
| | | 15:0 | — | — | — | — | SPIBUSY | — | — | — | — | SPIROV | — | — | SPITBE | — | — | — | SPIRBF | 0008 |
| 5820 | SPI1BUF | 31:16 | DATA<31:0> | | | | | | | | | | | | | | | 0000 | | |
| | | 15:0 | | | | | | | | | | | | | | | | 0000 | | |
| 5830 | SPI1BRG | 31:16 | — | — | — | — | — | — | — | — | — | — | — | — | — | — | — | — | — | 0000 |
| | | 15:0 | — | — | — | — | — | — | — | BRG<8:0> | | | | | | | | 0000 | | |
| 5A00 | SPI2CON | 31:16 | FRMEN | FRMSYNC | FRMPOL | — | — | — | — | — | — | — | — | — | — | — | — | SPIFE | — | 0008 |
| | | 15:0 | ON | — | SIDL | DISSDO | MODE32 | MODE16 | SMP | CKE | SSEN | CKP | MSTEN | — | — | — | — | — | — | 0000 |
| 5A10 | SPI2STAT | 31:16 | — | — | — | — | — | — | — | — | — | — | — | — | — | — | — | — | — | 0000 |
| | | 15:0 | — | — | — | — | SPIBUSY | — | — | — | — | SPIROV | — | — | SPITBE | — | — | — | SPIRBF | 0008 |
| 5A20 | SPI2BUF | 31:16 | DATA<31:0> | | | | | | | | | | | | | | | 0000 | | |
| | | 15:0 | | | | | | | | | | | | | | | | 0000 | | |
| 5A30 | SPI2BRG | 31:16 | — | — | — | — | — | — | — | — | — | — | — | — | — | — | — | — | — | 0000 |
| | | 15:0 | — | — | — | — | — | — | — | BRG<8:0> | | | | | | | | 0000 | | |

Legend: x = unknown value on Reset, — = unimplemented, read as '0'. Reset values are shown in hexadecimal.

- Note 1:** All registers in this table except SPIxBUF have corresponding CLR, SET and INV registers at their virtual addresses, plus offsets of 0x4, 0x8 and 0xC, respectively. See [Section 12.1.1 "CLR, SET and INV Registers"](#) for more information.
- Note 2:** SPI2 Module is not present on PIC32MX420FXXXX/440FXXXX devices.

TABLE 4-13: ADC REGISTERS MAP

| Virtual Address (BF80_#) | Register Name | Bit Range | Bits | | | | | | | | | | | | | | All Resets | |
|-----------------------------|------------------------|-----------|------------------------------------|--------|--------|-----------|------------|-----------|-------|-----------|-------|---------|-----------|------------|-------|-------|------------|-------|
| | | | 31/15 | 30/14 | 29/13 | 28/12 | 27/11 | 26/10 | 25/9 | 24/8 | 23/7 | 22/6 | 21/5 | 20/4 | 19/3 | 18/2 | | 17/1 |
| 9000 | AD1CON1 ⁽¹⁾ | 31:16 | — | — | — | — | — | — | — | — | — | — | — | — | — | — | — | 0000 |
| | | 15:0 | ON | — | SIDL | — | — | FORM<2:0> | | SSRC<2:0> | | CLRASAM | — | ASAM | SAMP | DONE | 0000 | |
| 9010 | AD1CON2 ⁽¹⁾ | 31:16 | — | — | — | — | — | — | — | — | — | — | — | — | — | — | — | 0000 |
| | | 15:0 | VCFG2 | VCFG1 | VCFG0 | OFFCAL | — | CSCNA | — | — | BUFS | — | SMPI<3:0> | | | BUFM | ALTS | 0000 |
| 9020 | AD1CON3 ⁽¹⁾ | 31:16 | — | — | — | — | — | — | — | — | — | — | — | — | — | — | — | 0000 |
| | | 15:0 | ADRC | — | — | SAMC<4:0> | | | | ADCS<7:0> | | | | | | | 0000 | |
| 9040 | AD1CHS ⁽¹⁾ | 31:16 | CH0NB | — | — | — | CH0SB<3:0> | | | CH0NA | — | — | — | CH0SA<3:0> | | | | 0000 |
| | | 15:0 | — | — | — | — | — | — | — | — | — | — | — | — | — | — | — | — |
| 9060 | AD1PCFG ⁽¹⁾ | 31:16 | — | — | — | — | — | — | — | — | — | — | — | — | — | — | — | 0000 |
| | | 15:0 | PCFG15 | PCFG14 | PCFG13 | PCFG12 | PCFG11 | PCFG10 | PCFG9 | PCFG8 | PCFG7 | PCFG6 | PCFG5 | PCFG4 | PCFG3 | PCFG2 | PCFG1 | PCFG0 |
| 9050 | AD1CSSL ⁽¹⁾ | 31:16 | — | — | — | — | — | — | — | — | — | — | — | — | — | — | — | 0000 |
| | | 15:0 | CSSL15 | CSSL14 | CSSL13 | CSSL12 | CSSL11 | CSSL10 | CSSL9 | CSSL8 | CSSL7 | CSSL6 | CSSL5 | CSSL4 | CSSL3 | CSSL2 | CSSL1 | CSSL0 |
| 9070 | ADC1BUF0 | 31:16 | ADC Result Word 0 (ADC1BUF0<31:0>) | | | | | | | | | | | | | | 0000 | |
| | | 15:0 | | | | | | | | | | | | | | | 0000 | |
| 9080 | ADC1BUF1 | 31:16 | ADC Result Word 1 (ADC1BUF1<31:0>) | | | | | | | | | | | | | | 0000 | |
| | | 15:0 | | | | | | | | | | | | | | | 0000 | |
| 9090 | ADC1BUF2 | 31:16 | ADC Result Word 2 (ADC1BUF2<31:0>) | | | | | | | | | | | | | | 0000 | |
| | | 15:0 | | | | | | | | | | | | | | | 0000 | |
| 90A0 | ADC1BUF3 | 31:16 | ADC Result Word 3 (ADC1BUF3<31:0>) | | | | | | | | | | | | | | 0000 | |
| | | 15:0 | | | | | | | | | | | | | | | 0000 | |
| 90B0 | ADC1BUF4 | 31:16 | ADC Result Word 4 (ADC1BUF4<31:0>) | | | | | | | | | | | | | | 0000 | |
| | | 15:0 | | | | | | | | | | | | | | | 0000 | |
| 90C0 | ADC1BUF5 | 31:16 | ADC Result Word 5 (ADC1BUF5<31:0>) | | | | | | | | | | | | | | 0000 | |
| | | 15:0 | | | | | | | | | | | | | | | 0000 | |
| 90D0 | ADC1BUF6 | 31:16 | ADC Result Word 6 (ADC1BUF6<31:0>) | | | | | | | | | | | | | | 0000 | |
| | | 15:0 | | | | | | | | | | | | | | | 0000 | |
| 90E0 | ADC1BUF7 | 31:16 | ADC Result Word 7 (ADC1BUF7<31:0>) | | | | | | | | | | | | | | 0000 | |
| | | 15:0 | | | | | | | | | | | | | | | 0000 | |
| 90F0 | ADC1BUF8 | 31:16 | ADC Result Word 8 (ADC1BUF8<31:0>) | | | | | | | | | | | | | | 0000 | |
| | | 15:0 | | | | | | | | | | | | | | | 0000 | |
| 9100 | ADC1BUF9 | 31:16 | ADC Result Word 9 (ADC1BUF9<31:0>) | | | | | | | | | | | | | | 0000 | |
| | | 15:0 | | | | | | | | | | | | | | | 0000 | |

Legend: x = unknown value on Reset, — = unimplemented, read as '0'. Reset values are shown in hexadecimal.

Note 1: This register has corresponding CLR, SET and INV registers at its virtual address, plus an offset of 0x4, 0x8 and 0xC, respectively. See [Section 12.1.1 “CLR, SET and INV Registers”](#) for more information.

TABLE 4-13: ADC REGISTERS MAP (CONTINUED)

| Virtual Address (BF80_#) | Register Name | Bit Range | Bits | | | | | | | | | | | | | | All Resets |
|-----------------------------|------------------|-----------|------------------------------------|-------|-------|-------|-------|-------|------|------|------|------|------|------|------|------|------------|
| | | | 31/15 | 30/14 | 29/13 | 28/12 | 27/11 | 26/10 | 25/9 | 24/8 | 23/7 | 22/6 | 21/5 | 20/4 | 19/3 | 18/2 | |
| 9110 | ADC1BUFA | 31:16 | ADC Result Word A (ADC1BUFA<31:0>) | | | | | | | | | | | | | | 0000 |
| | | 15:0 | | | | | | | | | | | | | | | 0000 |
| 9120 | ADC1BUFB | 31:16 | ADC Result Word B (ADC1BUFB<31:0>) | | | | | | | | | | | | | | 0000 |
| | | 15:0 | | | | | | | | | | | | | | | 0000 |
| 9130 | ADC1BUFC | 31:16 | ADC Result Word C (ADC1BUFC<31:0>) | | | | | | | | | | | | | | 0000 |
| | | 15:0 | | | | | | | | | | | | | | | 0000 |
| 9140 | ADC1BUFD | 31:16 | ADC Result Word D (ADC1BUFD<31:0>) | | | | | | | | | | | | | | 0000 |
| | | 15:0 | | | | | | | | | | | | | | | 0000 |
| 9150 | ADC1BUFE | 31:16 | ADC Result Word E (ADC1BUFE<31:0>) | | | | | | | | | | | | | | 0000 |
| | | 15:0 | | | | | | | | | | | | | | | 0000 |
| 9160 | ADC1BUFF | 31:16 | ADC Result Word F (ADC1BUFF<31:0>) | | | | | | | | | | | | | | 0000 |
| | | 15:0 | | | | | | | | | | | | | | | 0000 |

Legend: x = unknown value on Reset, — = unimplemented, read as '0'. Reset values are shown in hexadecimal.

Note 1: This register has corresponding CLR, SET and INV registers at its virtual address, plus an offset of 0x4, 0x8 and 0xC, respectively. See [Section 12.1.1 “CLR, SET and INV Registers”](#) for more information.

TABLE 4-14: DMA GLOBAL REGISTERS MAP FOR PIC32MX340FXXXX/360FXXXX/440FXXXX/460XXXX DEVICES ONLY

| Virtual Address (BF88_#) | Register Name | Bit Range | Bits | | | | | | | | | | | | | | | All Resets | |
|-----------------------------|-----------------------|-----------|---------------|-------|-------|---------|-------|-------|------|------|------|------|------|------|------|------|------------|------------|------|
| | | | 31/15 | 30/14 | 29/13 | 28/12 | 27/11 | 26/10 | 25/9 | 24/8 | 23/7 | 22/6 | 21/5 | 20/4 | 19/3 | 18/2 | 17/1 | | 16/0 |
| 3000 | DMACON ⁽¹⁾ | 31:16 | — | — | — | — | — | — | — | — | — | — | — | — | — | — | — | — | 0000 |
| | | 15:0 | ON | — | SIDL | SUSPEND | — | — | — | — | — | — | — | — | — | — | — | — | — |
| 3010 | DMASTAT | 31:16 | — | — | — | — | — | — | — | — | — | — | — | — | — | — | — | — | 0000 |
| | | 15:0 | — | — | — | — | — | — | — | — | — | — | — | — | RDWR | — | DMACH<1:0> | — | 0000 |
| 3020 | DMAADDR | 31:16 | DMAADDR<31:0> | | | | | | | | | | | | | | | 0000 | |
| | | 15:0 | | | | | | | | | | | | | | | | 0000 | |

Legend: x = unknown value on Reset, — = unimplemented, read as '0'. Reset values are shown in hexadecimal.

Note 1: This register has corresponding CLR, SET and INV registers at its virtual address, plus an offset of 0x4, 0x8 and 0xC, respectively. See [Section 12.1.1 “CLR, SET and INV Registers”](#) for more information.

TABLE 4-15: DMA CRC REGISTERS MAP FOR PIC32MX340FXXXX/360FXXXX/440FXXXX/460XXXX DEVICES ONLY⁽¹⁾

| Virtual Address (BF88_#) | Register Name | Bit Range | Bits | | | | | | | | | | | | | | | All Resets | |
|-----------------------------|------------------|-----------|----------------|-------|-------|-------|-----------|-------|------|------|-------|--------|------|------|------|------|------|------------|------|
| | | | 31/15 | 30/14 | 29/13 | 28/12 | 27/11 | 26/10 | 25/9 | 24/8 | 23/7 | 22/6 | 21/5 | 20/4 | 19/3 | 18/2 | 17/1 | | 16/0 |
| 3030 | DCRCCON | 31:16 | — | — | — | — | — | — | — | — | — | — | — | — | — | — | — | — | 0000 |
| | | 15:0 | — | — | — | — | PLEN<3:0> | | | | CRCEN | CRCAPP | — | — | — | — | — | CRCCH<1:0> | 0000 |
| 3040 | DCRCDATA | 31:16 | — | — | — | — | — | — | — | — | — | — | — | — | — | — | — | — | 0000 |
| | | 15:0 | DCRCDATA<15:0> | | | | | | | | | | | | | | | 0000 | |
| 3050 | DCRCXOR | 31:16 | — | — | — | — | — | — | — | — | — | — | — | — | — | — | — | — | 0000 |
| | | 15:0 | DCRCXOR<15:0> | | | | | | | | | | | | | | | 0000 | |

Legend: x = unknown value on Reset, — = unimplemented, read as '0'. Reset values are shown in hexadecimal.

Note 1: All registers in this table have corresponding CLR, SET and INV registers at their virtual addresses, plus offsets of 0x4, 0x8 and 0xC, respectively. See [Section 12.1.1 “CLR, SET and INV Registers”](#) for more information.

TABLE 4-16: DMA CHANNELS 0-3 REGISTERS MAP FOR PIC32MX340FXXXX/360FXXXX/440FXXXX/460XXXX DEVICES ONLY⁽¹⁾

| Virtual Address (BF88_#) | Register Name | Bit Range | Bits | | | | | | | | | | | | | | All Resets | | |
|--------------------------|---------------|-----------|-------------|-------|-------|-------|-------|-------|------|--------|--------|--------|--------|--------|--------|--------|------------|--------|--------|
| | | | 31/15 | 30/14 | 29/13 | 28/12 | 27/11 | 26/10 | 25/9 | 24/8 | 23/7 | 22/6 | 21/5 | 20/4 | 19/3 | 18/2 | | 17/1 | 16/0 |
| 3060 | DCH0CON | 31:16 | — | — | — | — | — | — | — | — | — | — | — | — | — | — | — | — | 0000 |
| | | 15:0 | — | — | — | — | — | — | — | CHCHNS | CHEN | CHAED | CHCHN | CHAEN | — | CHEDET | CHPRI<1:0> | — | 0000 |
| 3070 | DCH0ECON | 31:16 | — | — | — | — | — | — | — | — | — | — | — | — | — | — | — | — | 00FF |
| | | 15:0 | CHSIRQ<7:0> | | | | | | | CFORCE | CABORT | PATEN | SIRQEN | AIRQEN | — | — | — | — | FF00 |
| 3080 | DCH0INT | 31:16 | — | — | — | — | — | — | — | — | — | — | — | — | — | — | — | — | 0000 |
| | | 15:0 | — | — | — | — | — | — | — | — | — | CHSDIE | CHSHIE | CHDDIE | CHDHIE | CHBCIE | CHCCIE | CHTAIE | CHERIE |
| 3090 | DCH0SSA | 31:16 | CHSSA<31:0> | | | | | | | | | | | | | | 0000 | | |
| | | 15:0 | | | | | | | | | | | | | | | 0000 | | |
| 30A0 | DCH0DSA | 31:16 | CHDSA<31:0> | | | | | | | | | | | | | | 0000 | | |
| | | 15:0 | | | | | | | | | | | | | | | 0000 | | |
| 30B0 | DCH0SSIZ | 31:16 | — | — | — | — | — | — | — | — | — | — | — | — | — | — | — | — | 0000 |
| | | 15:0 | CHSSIZ<7:0> | | | | | | | | | | | | | | 0000 | | |
| 30C0 | DCH0DSIZ | 31:16 | — | — | — | — | — | — | — | — | — | — | — | — | — | — | — | — | 0000 |
| | | 15:0 | CHDSIZ<7:0> | | | | | | | | | | | | | | 0000 | | |
| 30D0 | DCH0SPTR | 31:16 | — | — | — | — | — | — | — | — | — | — | — | — | — | — | — | — | 0000 |
| | | 15:0 | CHSTR<7:0> | | | | | | | | | | | | | | 0000 | | |
| 30E0 | DCH0DPTR | 31:16 | — | — | — | — | — | — | — | — | — | — | — | — | — | — | — | — | 0000 |
| | | 15:0 | CHDPTR<7:0> | | | | | | | | | | | | | | 0000 | | |
| 30F0 | DCH0CSIZ | 31:16 | — | — | — | — | — | — | — | — | — | — | — | — | — | — | — | — | 0000 |
| | | 15:0 | CHCSIZ<7:0> | | | | | | | | | | | | | | 0000 | | |
| 3100 | DCH0CPTR | 31:16 | — | — | — | — | — | — | — | — | — | — | — | — | — | — | — | — | 0000 |
| | | 15:0 | CHCPTR<7:0> | | | | | | | | | | | | | | 0000 | | |
| 3110 | DCH0DAT | 31:16 | — | — | — | — | — | — | — | — | — | — | — | — | — | — | — | — | 0000 |
| | | 15:0 | CHPDAT<7:0> | | | | | | | | | | | | | | 0000 | | |
| 3120 | DCH1CON | 31:16 | — | — | — | — | — | — | — | — | — | — | — | — | — | — | — | — | 0000 |
| | | 15:0 | — | — | — | — | — | — | — | CHCHNS | CHEN | CHAED | CHCHN | CHAEN | — | CHEDET | CHPRI<1:0> | — | 0000 |
| 3130 | DCH1ECON | 31:16 | — | — | — | — | — | — | — | — | — | — | — | — | — | — | — | — | 00FF |
| | | 15:0 | CHSIRQ<7:0> | | | | | | | CFORCE | CABORT | PATEN | SIRQEN | AIRQEN | — | — | — | — | FF00 |
| 3140 | DCH1INT | 31:16 | — | — | — | — | — | — | — | — | — | — | — | — | — | — | — | — | 0000 |
| | | 15:0 | — | — | — | — | — | — | — | — | — | CHSDIE | CHSHIE | CHDDIE | CHDHIE | CHBCIE | CHCCIE | CHTAIE | CHERIE |
| 3150 | DCH1SSA | 31:16 | CHSSA<31:0> | | | | | | | | | | | | | | 0000 | | |
| | | 15:0 | | | | | | | | | | | | | | | 0000 | | |

Legend: x = unknown value on Reset, — = unimplemented, read as '0'. Reset values are shown in hexadecimal.

Note 1: All registers except DCHxSPTR, DCHxDPTR and DCHxCPTR have corresponding CLR, SET and INV registers at their virtual addresses, plus offsets of 0x4, 0x8 and 0xC, respectively. See [Section 12.1.1 "CLR, SET and INV Registers"](#) for more information.

TABLE 4-16: DMA CHANNELS 0-3 REGISTERS MAP FOR PIC32MX340FXXXX/360FXXXX/440FXXXX/460XXXX DEVICES ONLY⁽¹⁾ (CONTINUED)

| Virtual Address (BF88_#) | Register Name | Bit Range | Bits | | | | | | | | | | | | | | All Resets | | |
|--------------------------|---------------|-----------|-------------|-------|-------|-------|--------|--------|-------|--------|--------|--------|--------|--------|--------|--------|------------|--------|------|
| | | | 31/15 | 30/14 | 29/13 | 28/12 | 27/11 | 26/10 | 25/9 | 24/8 | 23/7 | 22/6 | 21/5 | 20/4 | 19/3 | 18/2 | | 17/1 | 16/0 |
| 3160 | DCH1DSA | 31:16 | CHDSA<31:0> | | | | | | | | | | | | | | 0000 | | |
| | | 15:0 | | | | | | | | | | | | | | | 0000 | | |
| 3170 | DCH1SSIZ | 31:16 | — | — | — | — | — | — | — | — | — | — | — | — | — | — | — | — | 0000 |
| | | 15:0 | CHSSIZ<7:0> | | | | | | | | | | | | | | 0000 | | |
| 3180 | DCH1DSIZ | 31:16 | — | — | — | — | — | — | — | — | — | — | — | — | — | — | — | — | 0000 |
| | | 15:0 | CHDSIZ<7:0> | | | | | | | | | | | | | | 0000 | | |
| 3190 | DCH1SPTR | 31:16 | — | — | — | — | — | — | — | — | — | — | — | — | — | — | — | — | 0000 |
| | | 15:0 | CHSPTR<7:0> | | | | | | | | | | | | | | 0000 | | |
| 31A0 | DCH1DPTR | 31:16 | — | — | — | — | — | — | — | — | — | — | — | — | — | — | — | — | 0000 |
| | | 15:0 | CHDPTR<7:0> | | | | | | | | | | | | | | 0000 | | |
| 31B0 | DCH1CSIZ | 31:16 | — | — | — | — | — | — | — | — | — | — | — | — | — | — | — | — | 0000 |
| | | 15:0 | CHCSIZ<7:0> | | | | | | | | | | | | | | 0000 | | |
| 31C0 | DCH1CPTR | 31:16 | — | — | — | — | — | — | — | — | — | — | — | — | — | — | — | — | 0000 |
| | | 15:0 | CHCPTR<7:0> | | | | | | | | | | | | | | 0000 | | |
| 31D0 | DCH1DAT | 31:16 | — | — | — | — | — | — | — | — | — | — | — | — | — | — | — | — | 0000 |
| | | 15:0 | CHPDAT<7:0> | | | | | | | | | | | | | | 0000 | | |
| 31E0 | DCH2CON | 31:16 | — | — | — | — | — | — | — | — | — | — | — | — | — | — | — | — | 0000 |
| | | 15:0 | — | — | — | — | — | — | — | CHCHNS | CHEN | CHAED | CHCHN | CHAEN | — | CHEDET | CHPRI<1:0> | — | 0000 |
| 31F0 | DCH2ECON | 31:16 | — | — | — | — | — | — | — | — | — | — | — | — | — | — | — | — | 00FF |
| | | 15:0 | CHSIRQ<7:0> | | | | CFORCE | CABORT | PATEN | SIRQEN | AIRQEN | — | — | — | — | — | — | — | FF00 |
| 3200 | DCH2INT | 31:16 | — | — | — | — | — | — | — | — | — | — | — | — | — | — | — | — | 0000 |
| | | 15:0 | — | — | — | — | — | — | — | — | CHSDIE | CHSHIE | CHDDIE | CHDHIE | CHBCIE | CHCCIE | CHTAIE | CHERIE | 0000 |
| 3210 | DCH2SSA | 31:16 | CHSSA<31:0> | | | | | | | | | | | | | | 0000 | | |
| | | 15:0 | | | | | | | | | | | | | | | 0000 | | |
| 3220 | DCH2DSA | 31:16 | CHDSA<31:0> | | | | | | | | | | | | | | 0000 | | |
| | | 15:0 | | | | | | | | | | | | | | | 0000 | | |
| 3230 | DCH2SSIZ | 31:16 | — | — | — | — | — | — | — | — | — | — | — | — | — | — | — | — | 0000 |
| | | 15:0 | CHSSIZ<7:0> | | | | | | | | | | | | | | 0000 | | |
| 3240 | DCH2DSIZ | 31:16 | — | — | — | — | — | — | — | — | — | — | — | — | — | — | — | — | 0000 |
| | | 15:0 | CHDSIZ<7:0> | | | | | | | | | | | | | | 0000 | | |
| 3250 | DCH2SPTR | 31:16 | — | — | — | — | — | — | — | — | — | — | — | — | — | — | — | — | 0000 |
| | | 15:0 | CHSPTR<7:0> | | | | | | | | | | | | | | 0000 | | |

Legend: x = unknown value on Reset, — = unimplemented, read as '0'. Reset values are shown in hexadecimal.

Note 1: All registers except DCHxSPTR, DCHxDPTR and DCHxCPTR have corresponding CLR, SET and INV registers at their virtual addresses, plus offsets of 0x4, 0x8 and 0xC, respectively. See [Section 12.1.1 "CLR, SET and INV Registers"](#) for more information.

TABLE 4-16: DMA CHANNELS 0-3 REGISTERS MAP FOR PIC32MX340FXXXX/360FXXXX/440FXXXX/460XXXX DEVICES ONLY⁽¹⁾ (CONTINUED)

| Virtual Address (BF68_#) | Register Name | Bit Range | Bits | | | | | | | | | | | | | | All Resets | |
|--------------------------|---------------|-----------|-------------|-------|-------|-------|-------|-------|--------|-------------|--------|--------|--------|--------|--------|--------|------------|------|
| | | | 31/15 | 30/14 | 29/13 | 28/12 | 27/11 | 26/10 | 25/9 | 24/8 | 23/7 | 22/6 | 21/5 | 20/4 | 19/3 | 18/2 | | 17/1 |
| 3260 | DCH2DPTR | 31:16 | — | — | — | — | — | — | — | — | — | — | — | — | — | — | — | 0000 |
| | | 15:0 | — | — | — | — | — | — | — | CHDPTR<7:0> | | | | | | | | 0000 |
| 3270 | DCH2CSIZ | 31:16 | — | — | — | — | — | — | — | — | — | — | — | — | — | — | — | 0000 |
| | | 15:0 | — | — | — | — | — | — | — | CHCSIZ<7:0> | | | | | | | | 0000 |
| 3280 | DCH2CPTR | 31:16 | — | — | — | — | — | — | — | — | — | — | — | — | — | — | — | 0000 |
| | | 15:0 | — | — | — | — | — | — | — | CHCPTR<7:0> | | | | | | | | 0000 |
| 3290 | DCH2DAT | 31:16 | — | — | — | — | — | — | — | — | — | — | — | — | — | — | — | 0000 |
| | | 15:0 | — | — | — | — | — | — | — | CHPDAT<7:0> | | | | | | | | 0000 |
| 32A0 | DCH3CON | 31:16 | — | — | — | — | — | — | — | — | — | — | — | — | — | — | — | 0000 |
| | | 15:0 | — | — | — | — | — | — | — | CHCHNS | CHEN | CHAED | CHCHN | CHAEN | — | CHEDET | CHPRI<1:0> | 0000 |
| 32B0 | DCH3ECON | 31:16 | — | — | — | — | — | — | — | CHAIRQ<7:0> | | | | | | | | 00FF |
| | | 15:0 | CHSIRQ<7:0> | | | | | | CFORCE | CABORT | PATEN | SIRQEN | AIRQEN | — | — | — | FF00 | |
| 32C0 | DCH3INT | 31:16 | — | — | — | — | — | — | — | — | — | — | — | — | — | — | — | 0000 |
| | | 15:0 | — | — | — | — | — | — | — | CHSDIE | CHSHIE | CHDDIE | CHDHIE | CHBCIE | CHCCIE | CHTAIE | CHERIE | 0000 |
| 32D0 | DCH3SSA | 31:16 | CHSSA<31:0> | | | | | | | | | | | | | | 0000 | |
| | | 15:0 | CHSSA<31:0> | | | | | | | | | | | | | | 0000 | |
| 32E0 | DCH3DSA | 31:16 | CHDSA<31:0> | | | | | | | | | | | | | | 0000 | |
| | | 15:0 | CHDSA<31:0> | | | | | | | | | | | | | | 0000 | |
| 32F0 | DCH3SSIZ | 31:16 | — | — | — | — | — | — | — | — | — | — | — | — | — | — | — | 0000 |
| | | 15:0 | — | — | — | — | — | — | — | CHSSIZ<7:0> | | | | | | | | 0000 |
| 3300 | DCH3DSIZ | 31:16 | — | — | — | — | — | — | — | — | — | — | — | — | — | — | — | 0000 |
| | | 15:0 | — | — | — | — | — | — | — | CHDSIZ<7:0> | | | | | | | | 0000 |
| 3310 | DCH3SPTR | 31:16 | — | — | — | — | — | — | — | — | — | — | — | — | — | — | — | 0000 |
| | | 15:0 | — | — | — | — | — | — | — | CHSTR<7:0> | | | | | | | | 0000 |
| 3320 | DCH3DPTR | 31:16 | — | — | — | — | — | — | — | — | — | — | — | — | — | — | — | 0000 |
| | | 15:0 | — | — | — | — | — | — | — | CHDPTR<7:0> | | | | | | | | 0000 |
| 3330 | DCH3CSIZ | 31:16 | — | — | — | — | — | — | — | — | — | — | — | — | — | — | — | 0000 |
| | | 15:0 | — | — | — | — | — | — | — | CHCSIZ<7:0> | | | | | | | | 0000 |
| 3340 | DCH3CPTR | 31:16 | — | — | — | — | — | — | — | — | — | — | — | — | — | — | — | 0000 |
| | | 15:0 | — | — | — | — | — | — | — | CHCPTR<7:0> | | | | | | | | 0000 |
| 3350 | DCH3DAT | 31:16 | — | — | — | — | — | — | — | — | — | — | — | — | — | — | — | 0000 |
| | | 15:0 | — | — | — | — | — | — | — | CHPDAT<7:0> | | | | | | | | 0000 |

Legend: x = unknown value on Reset, — = unimplemented, read as '0'. Reset values are shown in hexadecimal.

Note 1: All registers except DCHxSPTR, DCHxDPTR and DCHxCPTR have corresponding CLR, SET and INV registers at their virtual addresses, plus offsets of 0x4, 0x8 and 0xC, respectively. See [Section 12.1.1 "CLR, SET and INV Registers"](#) for more information.

TABLE 4-17: COMPARATOR REGISTERS MAP⁽¹⁾

| Virtual Address (BF80_#) | Register Name | Bit Range | Bits | | | | | | | | | | | | | | | All Resets |
|-----------------------------|------------------|-----------|-------|-------|-------|-------|-------|-------|------|------|------|------------|------|------|------|------|----------|------------|
| | | | 31/15 | 30/14 | 29/13 | 28/12 | 27/11 | 26/10 | 25/9 | 24/8 | 23/7 | 22/6 | 21/5 | 20/4 | 19/3 | 18/2 | 17/1 | |
| A000 | CM1CON | 31:16 | — | — | — | — | — | — | — | — | — | — | — | — | — | — | — | 0000 |
| | | 15:0 | ON | COE | CPOL | — | — | — | — | — | COUT | EVPOL<1:0> | — | CREF | — | — | CCH<1:0> | 00C3 |
| A010 | CM2CON | 31:16 | — | — | — | — | — | — | — | — | — | — | — | — | — | — | — | 0000 |
| | | 15:0 | ON | COE | CPOL | — | — | — | — | — | COUT | EVPOL<1:0> | — | CREF | — | — | CCH<1:0> | 00C3 |
| A060 | CMSTAT | 31:16 | — | — | — | — | — | — | — | — | — | — | — | — | — | — | — | 0000 |
| | | 15:0 | — | — | SIDL | — | — | — | — | — | — | — | — | — | — | — | C2OUT | C1OUT |

Legend: x = unknown value on Reset, — = unimplemented, read as '0'. Reset values are shown in hexadecimal.

Note 1: All registers in this table have corresponding CLR, SET and INV registers at their virtual addresses, plus offsets of 0x4, 0x8 and 0xC, respectively. See [Section 12.1.1 “CLR, SET and INV Registers”](#) for more information.

TABLE 4-18: COMPARATOR VOLTAGE REFERENCE REGISTERS MAP⁽¹⁾

| Virtual Address (BF80_#) | Register Name | Bit Range | Bits | | | | | | | | | | | | | | | All Resets |
|-----------------------------|------------------|-----------|-------|-------|-------|-------|-------|-------|------|------|------|------|-------|------|-------|----------|------|------------|
| | | | 31/15 | 30/14 | 29/13 | 28/12 | 27/11 | 26/10 | 25/9 | 24/8 | 23/7 | 22/6 | 21/5 | 20/4 | 19/3 | 18/2 | 17/1 | |
| 9800 | CVRCON | 31:16 | — | — | — | — | — | — | — | — | — | — | — | — | — | — | — | 0000 |
| | | 15:0 | ON | — | — | — | — | — | — | — | — | — | CVROE | CVRR | CVRSS | CVR<3:0> | | 0000 |

Legend: x = unknown value on Reset, — = unimplemented, read as '0'. Reset values are shown in hexadecimal.

Note 1: All registers in this table have corresponding CLR, SET and INV registers at their virtual addresses, plus offsets of 0x4, 0x8 and 0xC, respectively. See [Section 12.1.1 “CLR, SET and INV Registers”](#) for more information.

TABLE 4-19: FLASH CONTROLLER REGISTERS MAP

| Virtual Address (BF80_#) | Register Name | Bit Range | Bits | | | | | | | | | | | | | | All Resets | | |
|--------------------------|------------------------|-----------|------------------|-------|-------|--------|---------|-------|------|------|------|------|------|------|------------|------|------------|------|------|
| | | | 31/15 | 30/14 | 29/13 | 28/12 | 27/11 | 26/10 | 25/9 | 24/8 | 23/7 | 22/6 | 21/5 | 20/4 | 19/3 | 18/2 | | 17/1 | 16/0 |
| F400 | NVMCON ⁽¹⁾ | 31:16 | — | — | — | — | — | — | — | — | — | — | — | — | — | — | — | — | 0000 |
| | | 15:0 | WR | WREN | WRERR | LVDERR | LVDSTAT | — | — | — | — | — | — | — | NVMOP<3:0> | | | 0000 | |
| F410 | NVMKEY | 31:16 | NVMKEY<31:0> | | | | | | | | | | | | | | 0000 | | |
| | | 15:0 | | | | | | | | | | | | | | | 0000 | | |
| F420 | NVMADDR ⁽¹⁾ | 31:16 | NVMADDR<31:0> | | | | | | | | | | | | | | 0000 | | |
| | | 15:0 | | | | | | | | | | | | | | | 0000 | | |
| F430 | NVMDATA | 31:16 | NVMDATA<31:0> | | | | | | | | | | | | | | 0000 | | |
| | | 15:0 | | | | | | | | | | | | | | | 0000 | | |
| F440 | NVMSRC ADDR | 31:16 | NVMSRCADDR<31:0> | | | | | | | | | | | | | | 0000 | | |
| | | 15:0 | | | | | | | | | | | | | | | 0000 | | |

Legend: x = unknown value on Reset, — = unimplemented, read as '0'. Reset values are shown in hexadecimal.

Note 1: This register has corresponding CLR, SET and INV registers at its virtual address, plus an offset of 0x4, 0x8 and 0xC, respectively. See [Section 12.1.1 “CLR, SET and INV Registers”](#) for more information.

TABLE 4-20: SYSTEM CONTROL REGISTERS MAP^(1,2)

| Virtual Address (BF80_#) | Register Name | Bit Range | Bits | | | | | | | | | | | | | | All Resets | | |
|--------------------------|-----------------------|-----------|--------------|-----------|--------------|-------|-------|-------------|------|-------|-------------|----------|-------|------------|-------|--------------|------------|-------|------|
| | | | 31/15 | 30/14 | 29/13 | 28/12 | 27/11 | 26/10 | 25/9 | 24/8 | 23/7 | 22/6 | 21/5 | 20/4 | 19/3 | 18/2 | | 17/1 | 16/0 |
| F000 | OSCCON | 31:16 | — | — | PLLODIV<2:0> | | | FRCDIV<2:0> | | | — | SOSCRDY | — | PBDIV<1:0> | | PLLMULT<2:0> | | | 0000 |
| | | 15:0 | — | COSC<2:0> | | | — | NOSC<2:0> | | | CLKLOCK | ULOCK | SLOCK | SLPEN | CF | UFRNCN | SOSCEN | OSWEN | 0000 |
| F010 | OSCTUN | 31:16 | — | — | — | — | — | — | — | — | — | — | — | — | — | — | — | 0000 | |
| | | 15:0 | — | — | — | — | — | — | — | — | — | TUN<5:0> | | | | | 0000 | | |
| 0000 | WDTCON | 31:16 | — | — | — | — | — | — | — | — | — | — | — | — | — | — | — | 0000 | |
| | | 15:0 | ON | — | — | — | — | — | — | — | SWDTPS<4:0> | | | | | — | WDTCLR | 0000 | |
| F600 | RCON | 31:16 | — | — | — | — | — | — | — | — | — | — | — | — | — | — | — | 0000 | |
| | | 15:0 | — | — | — | — | — | — | CMR | VREGS | EXTR | SWR | — | WDTO | SLEEP | IDLE | BOR | POR | 0000 |
| F610 | RSWRST | 31:16 | — | — | — | — | — | — | — | — | — | — | — | — | — | — | — | 0000 | |
| | | 15:0 | — | — | — | — | — | — | — | — | — | — | — | — | — | — | — | SWRST | 0000 |
| F230 | SYSKEY ⁽³⁾ | 31:16 | SYSKEY<31:0> | | | | | | | | | | | | | | 0000 | | |
| | | 15:0 | | | | | | | | | | | | | | | 0000 | | |

Legend: x = unknown value on Reset, — = unimplemented, read as '0'. Reset values are shown in hexadecimal.

Note 1: Except where noted, all registers in this table have corresponding CLR, SET and INV registers at their virtual addresses, plus offsets of 0x4, 0x8 and 0xC, respectively. See [Section 12.1.1 “CLR, SET and INV Registers”](#) for more information.

2: Reset values are dependent on the DEVCFGx Configuration bits and the type of reset.

3: This register does not have associated CLR, SET, and INV registers.

TABLE 4-21: PORTA REGISTERS MAP FOR PIC32MX320F128L, PIC32MX340F128L, PIC32MX360F256L, PIC32MX360F512L, PIC32MX440F128L, PIC32MX460F256L AND PIC32MX460F512L DEVICES ONLY⁽¹⁾

| Virtual Address (BF88_#) | Register Name | Bit Range | Bits | | | | | | | | | | | | | | | | All Resets |
|--------------------------|---------------|-----------|---------|---------|-------|-------|-------|-------|---------|--------|------|--------|--------|--------|--------|--------|--------|--------|------------|
| | | | 31/15 | 30/14 | 29/13 | 28/12 | 27/11 | 26/10 | 25/9 | 24/8 | 23/7 | 22/6 | 21/5 | 20/4 | 19/3 | 18/2 | 17/1 | 16/0 | |
| 6000 | TRISA | 31:16 | — | — | — | — | — | — | — | — | — | — | — | — | — | — | — | — | 0000 |
| | | 15:0 | TRISA15 | TRISA14 | — | — | — | — | TRISA10 | TRISA9 | — | TRISA7 | TRISA6 | TRISA5 | TRISA4 | TRISA3 | TRISA2 | TRISA1 | TRISA0 |
| 6010 | PORTA | 31:16 | — | — | — | — | — | — | — | — | — | — | — | — | — | — | — | — | 0000 |
| | | 15:0 | RA15 | RA14 | — | — | — | — | RA10 | RA9 | — | RA7 | RA6 | RA5 | RA4 | RA3 | RA2 | RA1 | RA0 |
| 6020 | LATA | 31:16 | — | — | — | — | — | — | — | — | — | — | — | — | — | — | — | — | 0000 |
| | | 15:0 | LATA15 | LATA14 | — | — | — | — | LATA10 | LATA9 | — | LATA7 | LATA6 | LATA5 | LATA4 | LATA3 | LATA2 | LATA1 | LATA0 |
| 6030 | ODCA | 31:16 | — | — | — | — | — | — | — | — | — | — | — | — | — | — | — | — | 0000 |
| | | 15:0 | ODCA15 | ODCA14 | — | — | — | — | ODCA10 | ODCA9 | — | ODCA7 | ODCA6 | ODCA5 | ODCA4 | ODCA3 | ODCA2 | ODCA1 | ODCA0 |

Legend: x = unknown value on Reset, — = unimplemented, read as '0'. Reset values are shown in hexadecimal.

Note 1: All registers in this table have corresponding CLR, SET and INV registers at their virtual addresses, plus offsets of 0x4, 0x8 and 0xC, respectively. See [Section 12.1.1 “CLR, SET and INV Registers”](#) for more information.

TABLE 4-22: PORTB REGISTERS MAP⁽¹⁾

| Virtual Address (BF88_#) | Register Name | Bit Range | Bits | | | | | | | | | | | | | | | | All Resets |
|--------------------------|---------------|-----------|---------|---------|---------|---------|---------|---------|--------|--------|--------|--------|--------|--------|--------|--------|--------|--------|------------|
| | | | 31/15 | 30/14 | 29/13 | 28/12 | 27/11 | 26/10 | 25/9 | 24/8 | 23/7 | 22/6 | 21/5 | 20/4 | 19/3 | 18/2 | 17/1 | 16/0 | |
| 6040 | TRISB | 31:16 | — | — | — | — | — | — | — | — | — | — | — | — | — | — | — | — | 0000 |
| | | 15:0 | TRISB15 | TRISB14 | TRISB13 | TRISB12 | TRISB11 | TRISB10 | TRISB9 | TRISB8 | TRISB7 | TRISB6 | TRISB5 | TRISB4 | TRISB3 | TRISB2 | TRISB1 | TRISB0 | FFFF |
| 6050 | PORTB | 31:16 | — | — | — | — | — | — | — | — | — | — | — | — | — | — | — | — | 0000 |
| | | 15:0 | RB15 | RB14 | RB13 | RB12 | RB11 | RB10 | RB9 | RB8 | RB7 | RB6 | RB5 | RB4 | RB3 | RB2 | RB1 | RB0 | xxxx |
| 6060 | LATB | 31:16 | — | — | — | — | — | — | — | — | — | — | — | — | — | — | — | — | 0000 |
| | | 15:0 | LATB15 | LATB14 | LATB13 | LATB12 | LATB11 | LATB10 | LATB9 | LATB8 | LATB7 | LATB6 | LATB5 | LATB4 | LATB3 | LATB2 | LATB1 | LATB0 | xxxx |
| 6070 | ODCB | 31:16 | — | — | — | — | — | — | — | — | — | — | — | — | — | — | — | — | 0000 |
| | | 15:0 | ODCB15 | ODCB14 | ODCB13 | ODCB12 | ODCB11 | ODCB10 | ODCB9 | ODCB8 | ODCB7 | ODCB6 | ODCB5 | ODCB4 | ODCB3 | ODCB2 | ODCB1 | ODCB0 | 0000 |

Legend: x = unknown value on Reset, — = unimplemented, read as '0'. Reset values are shown in hexadecimal.

Note 1: All registers in this table have corresponding CLR, SET and INV registers at their virtual addresses, plus offsets of 0x4, 0x8 and 0xC, respectively. See [Section 12.1.1 “CLR, SET and INV Registers”](#) for more information.

TABLE 4-23: PORTC REGISTERS MAP FOR PIC32MX320F128L, PIC32MX340F128L, PIC32MX360F256L, PIC32MX360F512L, PIC32MX440F128L, PIC32MX460F256L AND PIC32MX460F512L DEVICES ONLY⁽¹⁾

| Virtual Address (BF88_#) | Register Name | Bit Range | Bits | | | | | | | | | | | | | | | All Resets | |
|--------------------------|---------------|-----------|---------|---------|---------|---------|-------|-------|------|------|------|------|------|--------|--------|--------|--------|------------|------|
| | | | 31/15 | 30/14 | 29/13 | 28/12 | 27/11 | 26/10 | 25/9 | 24/8 | 23/7 | 22/6 | 21/5 | 20/4 | 19/3 | 18/2 | 17/1 | | 16/0 |
| 6080 | TRISC | 31:16 | — | — | — | — | — | — | — | — | — | — | — | — | — | — | — | — | 0000 |
| | | 15:0 | TRISC15 | TRISC14 | TRISC13 | TRISC12 | — | — | — | — | — | — | — | TRISC4 | TRISC3 | TRISC2 | TRISC1 | — | F01E |
| 6090 | PORTC | 31:16 | — | — | — | — | — | — | — | — | — | — | — | — | — | — | — | — | 0000 |
| | | 15:0 | RC15 | RC14 | RC13 | RC12 | — | — | — | — | — | — | — | RC4 | RC3 | RC2 | RC1 | — | xxxx |
| 60A0 | LATC | 31:16 | — | — | — | — | — | — | — | — | — | — | — | — | — | — | — | — | 0000 |
| | | 15:0 | LATC15 | LATC14 | LATC13 | LATC12 | — | — | — | — | — | — | — | LATC4 | LATC3 | LATC2 | LATC1 | — | xxxx |
| 60B0 | ODCC | 31:16 | — | — | — | — | — | — | — | — | — | — | — | — | — | — | — | — | 0000 |
| | | 15:0 | ODCC15 | ODCC14 | ODCC13 | ODCC12 | — | — | — | — | — | — | — | ODCC4 | ODCC3 | ODCC2 | ODCC1 | — | 0000 |

Legend: x = unknown value on Reset, — = unimplemented, read as '0'. Reset values are shown in hexadecimal.

Note 1: All registers in this table have corresponding CLR, SET and INV registers at their virtual addresses, plus offsets of 0x4, 0x8 and 0xC, respectively. See [Section 12.1.1 “CLR, SET and INV Registers”](#) for more information.

TABLE 4-24: PORTC REGISTERS MAP FOR PIC32MX320F032H, PIC32MX320F064H, PIC32MX320F128H, PIC32MX340F128H, PIC32MX340F256H, PIC32MX340F512H, PIC32MX420F032H, PIC32MX440F128H, PIC32MX440F256H AND PIC32MX440F512H DEVICES ONLY⁽¹⁾

| Virtual Address (BF88_#) | Register Name | Bit Range | Bits | | | | | | | | | | | | | | | All Resets | |
|--------------------------|---------------|-----------|---------|---------|---------|---------|-------|-------|------|------|------|------|------|------|------|------|------|------------|------|
| | | | 31/15 | 30/14 | 29/13 | 28/12 | 27/11 | 26/10 | 25/9 | 24/8 | 23/7 | 22/6 | 21/5 | 20/4 | 19/3 | 18/2 | 17/1 | | 16/0 |
| 6080 | TRISC | 31:16 | — | — | — | — | — | — | — | — | — | — | — | — | — | — | — | — | 0000 |
| | | 15:0 | TRISC15 | TRISC14 | TRISC13 | TRISC12 | — | — | — | — | — | — | — | — | — | — | — | — | F000 |
| 6090 | PORTC | 31:16 | — | — | — | — | — | — | — | — | — | — | — | — | — | — | — | — | 0000 |
| | | 15:0 | RC15 | RC14 | RC13 | RC12 | — | — | — | — | — | — | — | — | — | — | — | — | xxxx |
| 60A0 | LATC | 31:16 | — | — | — | — | — | — | — | — | — | — | — | — | — | — | — | — | 0000 |
| | | 15:0 | LATC15 | LATC14 | LATC13 | LATC12 | — | — | — | — | — | — | — | — | — | — | — | — | xxxx |
| 60B0 | ODCC | 31:16 | — | — | — | — | — | — | — | — | — | — | — | — | — | — | — | — | 0000 |
| | | 15:0 | ODCC15 | ODCC14 | ODCC13 | ODCC12 | — | — | — | — | — | — | — | — | — | — | — | — | 0000 |

Legend: x = unknown value on Reset, — = unimplemented, read as '0'. Reset values are shown in hexadecimal.

Note 1: All registers in this table have corresponding CLR, SET and INV registers at their virtual addresses, plus offsets of 0x4, 0x8 and 0xC, respectively. See [Section 12.1.1 “CLR, SET and INV Registers”](#) for more information.

TABLE 4-25: PORTD REGISTERS MAP FOR PIC32MX320F128L, PIC32MX340F128L, PIC32MX360F256L, PIC32MX360F512L, PIC32MX440F128L, PIC32MX460F256L AND PIC32MX460F512L DEVICES ONLY⁽¹⁾

| Virtual Address (BF88_#) | Register Name | Bit Range | Bits | | | | | | | | | | | | | | | | All Resets |
|--------------------------|---------------|-----------|---------|---------|---------|---------|---------|---------|--------|--------|--------|--------|--------|--------|--------|--------|--------|--------|------------|
| | | | 31/15 | 30/14 | 29/13 | 28/12 | 27/11 | 26/10 | 25/9 | 24/8 | 23/7 | 22/6 | 21/5 | 20/4 | 19/3 | 18/2 | 17/1 | 16/0 | |
| 60C0 | TRISD | 31:16 | — | — | — | — | — | — | — | — | — | — | — | — | — | — | — | — | 0000 |
| | | 15:0 | TRISD15 | TRISD14 | TRISD13 | TRISD12 | TRISD11 | TRISD10 | TRISD9 | TRISD8 | TRISD7 | TRISD6 | TRISD5 | TRISD4 | TRISD3 | TRISD2 | TRISD1 | TRISD0 | FFFF |
| 60D0 | PORTD | 31:16 | — | — | — | — | — | — | — | — | — | — | — | — | — | — | — | — | 0000 |
| | | 15:0 | RD15 | RD14 | RD13 | RD12 | RD11 | RD10 | RD9 | RD8 | RD7 | RD6 | RD5 | RD4 | RD3 | RD2 | RD1 | RD0 | xxxx |
| 60E0 | LATD | 31:16 | — | — | — | — | — | — | — | — | — | — | — | — | — | — | — | — | 0000 |
| | | 15:0 | LATD15 | LATD14 | LATD13 | LATD12 | LATD11 | LATD10 | LATD9 | LATD8 | LATD7 | LATD6 | LATD5 | LATD4 | LATD3 | LATD2 | LATD1 | LATD0 | xxxx |
| 60F0 | ODCD | 31:16 | — | — | — | — | — | — | — | — | — | — | — | — | — | — | — | — | 0000 |
| | | 15:0 | ODCD15 | ODCD14 | ODCD13 | ODCD12 | ODCD11 | ODCD10 | ODCD9 | ODCD8 | ODCD7 | ODCD6 | ODCD5 | ODCD4 | ODCD3 | ODCD2 | ODCD1 | ODCD0 | 0000 |

Legend: x = unknown value on Reset, — = unimplemented, read as '0'. Reset values are shown in hexadecimal.

Note 1: All registers in this table have corresponding CLR, SET and INV registers at their virtual addresses, plus offsets of 0x4, 0x8 and 0xC, respectively. See [Section 12.1.1 “CLR, SET and INV Registers”](#) for more information.

TABLE 4-26: PORTD REGISTERS MAP FOR PIC32MX320F032H, PIC32MX320F064H, PIC32MX320F128H, PIC32MX340F128H, PIC32MX340F256H, PIC32MX340F512H, PIC32MX420F032H, PIC32MX440F128H, PIC32MX440F256H AND PIC32MX440F512H DEVICES ONLY⁽¹⁾

| Virtual Address (BF88_#) | Register Name | Bit Range | Bits | | | | | | | | | | | | | | | | All Resets |
|--------------------------|---------------|-----------|-------|-------|-------|-------|---------|---------|--------|--------|--------|--------|--------|--------|--------|--------|--------|--------|------------|
| | | | 31/15 | 30/14 | 29/13 | 28/12 | 27/11 | 26/10 | 25/9 | 24/8 | 23/7 | 22/6 | 21/5 | 20/4 | 19/3 | 18/2 | 17/1 | 16/0 | |
| 60C0 | TRISD | 31:16 | — | — | — | — | — | — | — | — | — | — | — | — | — | — | — | — | 0000 |
| | | 15:0 | — | — | — | — | TRISD11 | TRISD10 | TRISD9 | TRISD8 | TRISD7 | TRISD6 | TRISD5 | TRISD4 | TRISD3 | TRISD2 | TRISD1 | TRISD0 | 0FFF |
| 60D0 | PORTD | 31:16 | — | — | — | — | — | — | — | — | — | — | — | — | — | — | — | — | 0000 |
| | | 15:0 | — | — | — | — | RD11 | RD10 | RD9 | RD8 | RD7 | RD6 | RD5 | RD4 | RD3 | RD2 | RD1 | RD0 | xxxx |
| 60E0 | LATD | 31:16 | — | — | — | — | — | — | — | — | — | — | — | — | — | — | — | — | 0000 |
| | | 15:0 | — | — | — | — | LATD11 | LATD10 | LATD9 | LATD8 | LATD7 | LATD6 | LATD5 | LATD4 | LATD3 | LATD2 | LATD1 | LATD0 | xxxx |
| 60F0 | ODCD | 31:16 | — | — | — | — | — | — | — | — | — | — | — | — | — | — | — | — | 0000 |
| | | 15:0 | — | — | — | — | ODCD11 | ODCD10 | ODCD9 | ODCD8 | ODCD7 | ODCD6 | ODCD5 | ODCD4 | ODCD3 | ODCD2 | ODCD1 | ODCD0 | 0000 |

Legend: x = unknown value on Reset, — = unimplemented, read as '0'. Reset values are shown in hexadecimal.

Note 1: All registers in this table have corresponding CLR, SET and INV registers at their virtual addresses, plus offsets of 0x4, 0x8 and 0xC, respectively. See [Section 12.1.1 “CLR, SET and INV Registers”](#) for more information.

TABLE 4-27: PORTE REGISTERS MAP FOR PIC32MX320F128L, PIC32MX340F128L, PIC32MX360F256L, PIC32MX360F512L, PIC32MX440F128L, PIC32MX460F256L AND PIC32MX460F512L DEVICES ONLY⁽¹⁾

| Virtual Address (BF88_#) | Register Name | Bit Range | Bits | | | | | | | | | | | | | | | | All Resets |
|--------------------------|---------------|-----------|-------|-------|-------|-------|-------|-------|--------|--------|--------|--------|--------|--------|--------|--------|--------|--------|------------|
| | | | 31/15 | 30/14 | 29/13 | 28/12 | 27/11 | 26/10 | 25/9 | 24/8 | 23/7 | 22/6 | 21/5 | 20/4 | 19/3 | 18/2 | 17/1 | 16/0 | |
| 6100 | TRISE | 31:16 | — | — | — | — | — | — | — | — | — | — | — | — | — | — | — | — | 0000 |
| | | 15:0 | — | — | — | — | — | — | TRISE9 | TRISE8 | TRISE7 | TRISE6 | TRISE5 | TRISE4 | TRISE3 | TRISE2 | TRISE1 | TRISE0 | 03FF |
| 6110 | PORTE | 31:16 | — | — | — | — | — | — | — | — | — | — | — | — | — | — | — | — | 0000 |
| | | 15:0 | — | — | — | — | — | — | RE9 | RE8 | RE7 | RE6 | RE5 | RE4 | RE3 | RE2 | RE1 | RE0 | xxxx |
| 6120 | LATE | 31:16 | — | — | — | — | — | — | — | — | — | — | — | — | — | — | — | — | 0000 |
| | | 15:0 | — | — | — | — | — | — | LATE9 | LATE8 | LATE7 | LATE6 | LATE5 | LATE4 | LATE3 | LATE2 | LATE1 | LATE0 | xxxx |
| 6130 | ODCE | 31:16 | — | — | — | — | — | — | — | — | — | — | — | — | — | — | — | — | 0000 |
| | | 15:0 | — | — | — | — | — | — | ODCE9 | ODCE8 | ODCE7 | ODCE6 | ODCE5 | ODCE4 | ODCE3 | ODCE2 | ODCE1 | ODCE0 | 0000 |

Legend: x = unknown value on Reset, — = unimplemented, read as '0'. Reset values are shown in hexadecimal.

Note 1: All registers in this table have corresponding CLR, SET and INV registers at their virtual addresses, plus offsets of 0x4, 0x8 and 0xC, respectively. See [Section 12.1.1 “CLR, SET and INV Registers”](#) for more information.

TABLE 4-28: PORTE REGISTERS MAP FOR PIC32MX320F032H, PIC32MX320F064H, PIC32MX320F128H, PIC32MX340F128H, PIC32MX340F256H, PIC32MX340F512H, PIC32MX420F032H, PIC32MX440F128H, PIC32MX440F256H AND PIC32MX440F512H DEVICES ONLY⁽¹⁾

| Virtual Address (BF88_#) | Register Name | Bit Range | Bits | | | | | | | | | | | | | | | | All Resets |
|--------------------------|---------------|-----------|-------|-------|-------|-------|-------|-------|------|------|--------|--------|--------|--------|--------|--------|--------|--------|------------|
| | | | 31/15 | 30/14 | 29/13 | 28/12 | 27/11 | 26/10 | 25/9 | 24/8 | 23/7 | 22/6 | 21/5 | 20/4 | 19/3 | 18/2 | 17/1 | 16/0 | |
| 6100 | TRISE | 31:16 | — | — | — | — | — | — | — | — | — | — | — | — | — | — | — | — | 0000 |
| | | 15:0 | — | — | — | — | — | — | — | — | TRISE7 | TRISE6 | TRISE5 | TRISE4 | TRISE3 | TRISE2 | TRISE1 | TRISE0 | 00FF |
| 6110 | PORTE | 31:16 | — | — | — | — | — | — | — | — | — | — | — | — | — | — | — | — | 0000 |
| | | 15:0 | — | — | — | — | — | — | — | — | RE7 | RE6 | RE5 | RE4 | RE3 | RE2 | RE1 | RE0 | xxxx |
| 6120 | LATE | 31:16 | — | — | — | — | — | — | — | — | — | — | — | — | — | — | — | — | 0000 |
| | | 15:0 | — | — | — | — | — | — | — | — | LATE7 | LATE6 | LATE5 | LATE4 | LATE3 | LATE2 | LATE1 | LATE0 | xxxx |
| 6130 | ODCE | 31:16 | — | — | — | — | — | — | — | — | — | — | — | — | — | — | — | — | 0000 |
| | | 15:0 | — | — | — | — | — | — | — | — | ODCE7 | ODCE6 | ODCE5 | ODCE4 | ODCE3 | ODCE2 | ODCE1 | ODCE0 | 0000 |

Legend: x = unknown value on Reset, — = unimplemented, read as '0'. Reset values are shown in hexadecimal.

Note 1: All registers in this table have corresponding CLR, SET and INV registers at their virtual addresses, plus offsets of 0x4, 0x8 and 0xC, respectively. See [Section 12.1.1 “CLR, SET and INV Registers”](#) for more information.

TABLE 4-29: PORTF REGISTERS MAP FOR PIC32MX320F128L, PIC32MX340F128L, PIC32MX360F256L AND PIC32MX360F512L DEVICES ONLY⁽¹⁾

| Virtual Address (BF88_#) | Register Name | Bit Range | Bits | | | | | | | | | | | | | | | | All Resets |
|--------------------------|---------------|-----------|-------|-------|---------|---------|-------|-------|------|--------|--------|--------|--------|--------|--------|--------|--------|--------|------------|
| | | | 31/15 | 30/14 | 29/13 | 28/12 | 27/11 | 26/10 | 25/9 | 24/8 | 23/7 | 22/6 | 21/5 | 20/4 | 19/3 | 18/2 | 17/1 | 16/0 | |
| 6140 | TRISF | 31:16 | — | — | — | — | — | — | — | — | — | — | — | — | — | — | — | — | 0000 |
| | | 15:0 | — | — | TRISF13 | TRISF12 | — | — | — | TRISF8 | TRISF7 | TRISF6 | TRISF5 | TRISF4 | TRISF3 | TRISF2 | TRISF1 | TRISF0 | 31FF |
| 6150 | PORTF | 31:16 | — | — | — | — | — | — | — | — | — | — | — | — | — | — | — | — | 0000 |
| | | 15:0 | — | — | RF13 | RF12 | — | — | — | RF8 | RF7 | RF6 | RF5 | RF4 | RF3 | RF2 | RF1 | RF0 | xxxx |
| 6160 | LATF | 31:16 | — | — | — | — | — | — | — | — | — | — | — | — | — | — | — | — | 0000 |
| | | 15:0 | — | — | LATF13 | LATF12 | — | — | — | LATF8 | LATF7 | LATF6 | LATF5 | LATF4 | LATF3 | LATF2 | LATF1 | LATF0 | xxxx |
| 6170 | ODCF | 31:16 | — | — | — | — | — | — | — | — | — | — | — | — | — | — | — | — | 0000 |
| | | 15:0 | — | — | ODCF13 | ODCF12 | — | — | — | ODCF8 | ODCF7 | ODCF6 | ODCF5 | ODCF4 | ODCF3 | ODCF2 | ODCF1 | ODCF0 | 0000 |

Legend: x = unknown value on Reset, — = unimplemented, read as '0'. Reset values are shown in hexadecimal.

Note 1: All registers in this table have corresponding CLR, SET and INV registers at their virtual addresses, plus offsets of 0x4, 0x8 and 0xC, respectively. See [Section 12.1.1 “CLR, SET and INV Registers”](#) for more information.

TABLE 4-30: PORTF REGISTERS MAP FOR PIC32MX440F128L, PIC32MX460F256L AND PIC32MX460F512L DEVICES ONLY⁽¹⁾

| Virtual Address (BF88_#) | Register Name | Bit Range | Bits | | | | | | | | | | | | | | | | All Resets |
|--------------------------|---------------|-----------|-------|-------|---------|---------|-------|-------|------|--------|------|------|--------|--------|--------|--------|--------|--------|------------|
| | | | 31/15 | 30/14 | 29/13 | 28/12 | 27/11 | 26/10 | 25/9 | 24/8 | 23/7 | 22/6 | 21/5 | 20/4 | 19/3 | 18/2 | 17/1 | 16/0 | |
| 6140 | TRISF | 31:16 | — | — | — | — | — | — | — | — | — | — | — | — | — | — | — | — | 0000 |
| | | 15:0 | — | — | TRISF13 | TRISF12 | — | — | — | TRISF8 | — | — | TRISF5 | TRISF4 | TRISF3 | TRISF2 | TRISF1 | TRISF0 | 313F |
| 6150 | PORTF | 31:16 | — | — | — | — | — | — | — | — | — | — | — | — | — | — | — | — | 0000 |
| | | 15:0 | — | — | RF13 | RF12 | — | — | — | RF8 | — | — | RF5 | RF4 | RF3 | RF2 | RF1 | RF0 | xxxx |
| 6160 | LATF | 31:16 | — | — | — | — | — | — | — | — | — | — | — | — | — | — | — | — | 0000 |
| | | 15:0 | — | — | LATF13 | LATF12 | — | — | — | LATF8 | — | — | LATF5 | LATF4 | LATF3 | LATF2 | LATF1 | LATF0 | xxxx |
| 6170 | ODCF | 31:16 | — | — | — | — | — | — | — | — | — | — | — | — | — | — | — | — | 0000 |
| | | 15:0 | — | — | ODCF13 | ODCF12 | — | — | — | ODCF8 | — | — | ODCF5 | ODCF4 | ODCF3 | ODCF2 | ODCF1 | ODCF0 | 0000 |

Legend: x = unknown value on Reset, — = unimplemented, read as '0'. Reset values are shown in hexadecimal.

Note 1: All registers in this table have corresponding CLR, SET and INV registers at their virtual addresses, plus offsets of 0x4, 0x8 and 0xC, respectively. See [Section 12.1.1 “CLR, SET and INV Registers”](#) for more information.

TABLE 4-31: PORTF REGISTERS MAP FOR PIC32MX320F032H, PIC32MX320F064H, PIC32MX320F128H, PIC32MX340F128H, PIC32MX340F256H AND PIC32MX340F512H DEVICES ONLY⁽¹⁾

| Virtual Address (BF88_#) | Register Name | Bit Range | Bits | | | | | | | | | | | | | | | All Resets | |
|--------------------------|---------------|-----------|-------|-------|-------|-------|-------|-------|------|------|-------|--------|--------|--------|--------|--------|--------|------------|------|
| | | | 31/15 | 30/14 | 29/13 | 28/12 | 27/11 | 26/10 | 25/9 | 24/8 | 23/7 | 22/6 | 21/5 | 20/4 | 19/3 | 18/2 | 17/1 | | 16/0 |
| 6140 | TRISF | 31:16 | — | — | — | — | — | — | — | — | — | — | — | — | — | — | — | — | 0000 |
| | | 15:0 | — | — | — | — | — | — | — | — | — | TRISF6 | TRISF5 | TRISF4 | TRISF3 | TRISF2 | TRISF1 | TRISF0 | 07FF |
| 6150 | PORTF | 31:16 | — | — | — | — | — | — | — | — | — | — | — | — | — | — | — | 0000 | |
| | | 15:0 | — | — | — | — | — | — | — | — | RF6 | RF5 | RF4 | RF3 | RF2 | RF1 | RF0 | xxxx | |
| 6160 | LATF | 31:16 | — | — | — | — | — | — | — | — | — | — | — | — | — | — | — | 0000 | |
| | | 15:0 | — | — | — | — | — | — | — | — | LATF6 | LATF5 | LATF4 | LATF3 | LATF2 | LATF1 | LATF0 | xxxx | |
| 6170 | ODCF | 31:16 | — | — | — | — | — | — | — | — | — | — | — | — | — | — | — | 0000 | |
| | | 15:0 | — | — | — | — | — | — | — | — | ODCF6 | ODCF5 | ODCF4 | ODCF3 | ODCF2 | ODCF1 | ODCF0 | 0000 | |

Legend: x = unknown value on Reset, — = unimplemented, read as '0'. Reset values are shown in hexadecimal.

Note 1: All registers in this table have corresponding CLR, SET and INV registers at their virtual addresses, plus offsets of 0x4, 0x8 and 0xC, respectively. See [Section 12.1.1 “CLR, SET and INV Registers”](#) for more information.

TABLE 4-32: PORTF REGISTERS MAP FOR PIC32MX420F032H, PIC32MX440F128H AND PIC2MX440F256H DEVICES ONLY⁽¹⁾

| Virtual Address (BF88_#) | Register Name | Bit Range | Bits | | | | | | | | | | | | | | | All Resets |
|--------------------------|---------------|-----------|-------|-------|-------|-------|-------|-------|------|------|------|-------|--------|--------|--------|--------|--------|------------|
| | | | 31/15 | 30/14 | 29/13 | 28/12 | 27/11 | 26/10 | 25/9 | 24/8 | 23/7 | 22/6 | 21/5 | 20/4 | 19/3 | 18/2 | 17/1 | |
| 6140 | TRISF | 31:16 | — | — | — | — | — | — | — | — | — | — | — | — | — | — | — | 0000 |
| | | 15:0 | — | — | — | — | — | — | — | — | — | — | TRISF5 | TRISF4 | TRISF3 | TRISF2 | TRISF1 | TRISF0 |
| 6150 | PORTF | 31:16 | — | — | — | — | — | — | — | — | — | — | — | — | — | — | — | 0000 |
| | | 15:0 | — | — | — | — | — | — | — | — | — | RF5 | RF4 | RF3 | RF2 | RF1 | RF0 | xxxx |
| 6160 | LATF | 31:16 | — | — | — | — | — | — | — | — | — | — | — | — | — | — | — | 0000 |
| | | 15:0 | — | — | — | — | — | — | — | — | — | LATF5 | LATF4 | LATF3 | LATF2 | LATF1 | LATF0 | xxxx |
| 6170 | ODCF | 31:16 | — | — | — | — | — | — | — | — | — | — | — | — | — | — | — | 0000 |
| | | 15:0 | — | — | — | — | — | — | — | — | — | — | ODCF5 | ODCF4 | ODCF3 | ODCF2 | ODCF1 | ODCF0 |

Legend: x = unknown value on Reset, — = unimplemented, read as '0'. Reset values are shown in hexadecimal.

Note 1: All registers in this table have corresponding CLR, SET and INV registers at their virtual addresses, plus offsets of 0x4, 0x8 and 0xC, respectively. See [Section 12.1.1 “CLR, SET and INV Registers”](#) for more information.

TABLE 4-33: PORTG REGISTERS MAP FOR PIC32MX320F128L, PIC32MX340F128L, PIC32MX360F256L, PIC32MX360F512L, PIC32MX440F128L, PIC32MX460F256L AND PIC32MX460F512L DEVICES ONLY⁽¹⁾

| Virtual Address (BF88_#) | Register Name | Bit Range | Bits | | | | | | | | | | | | | | | All Resets | |
|--------------------------|---------------|-----------|---------|---------|---------|---------|-------|-------|--------|--------|--------|--------|------|------|--------|--------|--------|------------|------|
| | | | 31/15 | 30/14 | 29/13 | 28/12 | 27/11 | 26/10 | 25/9 | 24/8 | 23/7 | 22/6 | 21/5 | 20/4 | 19/3 | 18/2 | 17/1 | | 16/0 |
| 6180 | TRISG | 31:16 | — | — | — | — | — | — | — | — | — | — | — | — | — | — | — | — | 0000 |
| | | 15:0 | TRISG15 | TRISG14 | TRISG13 | TRISG12 | — | — | TRISG9 | TRISG8 | TRISG7 | TRISG6 | — | — | TRISG3 | TRISG2 | TRISG1 | TRISG0 | F3CF |
| 6190 | PORTG | 31:16 | — | — | — | — | — | — | — | — | — | — | — | — | — | — | — | — | 0000 |
| | | 15:0 | RG15 | RG14 | RG13 | RG12 | — | — | RG9 | RG8 | RG7 | RG6 | — | — | RG3 | RG2 | RG1 | RG0 | xxxx |
| 61A0 | LATG | 31:16 | — | — | — | — | — | — | — | — | — | — | — | — | — | — | — | — | 0000 |
| | | 15:0 | LATG15 | LATG14 | LATG13 | LATG12 | — | — | LATG9 | LATG8 | LATG7 | LATG6 | — | — | LATG3 | LATG2 | LATG1 | LATG0 | xxxx |
| 61B0 | ODCG | 31:16 | — | — | — | — | — | — | — | — | — | — | — | — | — | — | — | — | 0000 |
| | | 15:0 | ODCG15 | ODCG14 | ODCG13 | ODCG12 | — | — | ODCG9 | ODCG8 | ODCG7 | ODCG6 | — | — | ODCG3 | ODCG2 | ODCG1 | ODCG0 | 0000 |

Legend: x = unknown value on Reset, — = unimplemented, read as '0'. Reset values are shown in hexadecimal.

Note 1: All registers in this table have corresponding CLR, SET, and INV registers at their virtual addresses, plus offsets of 0x4, 0x8, and 0xC, respectively. See [Section 12.1.1 “CLR, SET and INV Registers”](#) for more information.

TABLE 4-34: PORTG REGISTERS MAP FOR PIC32MX320F032H, PIC32MX320F064H, PIC32MX320F128H, PIC32MX340F128H, PIC32MX340F256H, PIC32MX340F512H, PIC32MX420F032H, PIC32MX440F128H, PIC32MX440F256H AND PIC32MX440F512H DEVICES ONLY⁽¹⁾

| Virtual Address (BF88_#) | Register Name | Bit Range | Bits | | | | | | | | | | | | | | | All Resets | |
|--------------------------|---------------|-----------|-------|-------|-------|-------|-------|-------|--------|--------|--------|--------|------|------|--------|--------|------|------------|------|
| | | | 31/15 | 30/14 | 29/13 | 28/12 | 27/11 | 26/10 | 25/9 | 24/8 | 23/7 | 22/6 | 21/5 | 20/4 | 19/3 | 18/2 | 17/1 | | 16/0 |
| 6180 | TRISG | 31:16 | — | — | — | — | — | — | — | — | — | — | — | — | — | — | — | — | 0000 |
| | | 15:0 | — | — | — | — | — | — | TRISG9 | TRISG8 | TRISG7 | TRISG6 | — | — | TRISG3 | TRISG2 | — | — | 03cc |
| 6190 | PORTG | 31:16 | — | — | — | — | — | — | — | — | — | — | — | — | — | — | — | — | 0000 |
| | | 15:0 | — | — | — | — | — | — | RG9 | RG8 | RG7 | RG6 | — | — | RG3 | RG2 | — | — | xxxx |
| 61A0 | LATG | 31:16 | — | — | — | — | — | — | — | — | — | — | — | — | — | — | — | — | 0000 |
| | | 15:0 | — | — | — | — | — | — | LATG9 | LATG8 | LATG7 | LATG6 | — | — | LATG3 | LATG2 | — | — | xxxx |
| 61B0 | ODCG | 31:16 | — | — | — | — | — | — | — | — | — | — | — | — | — | — | — | — | 0000 |
| | | 15:0 | — | — | — | — | — | — | ODCG9 | ODCG8 | ODCG7 | ODCG6 | — | — | ODCG3 | ODCG2 | — | — | 0000 |

Legend: x = unknown value on Reset, — = unimplemented, read as '0'. Reset values are shown in hexadecimal.

Note 1: All registers in this table have corresponding CLR, SET and INV registers at their virtual addresses, plus offsets of 0x4, 0x8 and 0xC, respectively. See [Section 12.1.1 “CLR, SET and INV Registers”](#) for more information.

TABLE 4-35: CHANGE NOTICE AND PULL-UP REGISTERS MAP FOR PIC32MX320F128L, PIC32MX340F128L, PIC32MX360F256L, PIC32MX360F512L, PIC32MX440F128L, PIC32MX460F256L AND PIC32MX460F512L DEVICES ONLY⁽¹⁾

| Virtual Address (BF88_#) | Register Name | Bit Range | Bits | | | | | | | | | | | | | | | | All Resets | |
|--------------------------|---------------|-----------|---------|---------|---------|---------|---------|---------|--------|--------|--------|--------|--------|---------|---------|---------|---------|---------|------------|------|
| | | | 31/15 | 30/14 | 29/13 | 28/12 | 27/11 | 26/10 | 25/9 | 24/8 | 23/7 | 22/6 | 21/5 | 20/4 | 19/3 | 18/2 | 17/1 | 16/0 | | |
| 61C0 | CNCON | 31:16 | — | — | — | — | — | — | — | — | — | — | — | — | — | — | — | — | 0000 | |
| | | 15:0 | ON | — | SIDL | — | — | — | — | — | — | — | — | — | — | — | — | — | 0000 | |
| 61D0 | CNEN | 31:16 | — | — | — | — | — | — | — | — | — | — | — | CNEN21 | CNEN20 | CNEN19 | CNEN18 | CNEN17 | CNEN16 | 0000 |
| | | 15:0 | CNEN15 | CNEN14 | CNEN13 | CNEN12 | CNEN11 | CNEN10 | CNEN9 | CNEN8 | CNEN7 | CNEN6 | CNEN5 | CNEN4 | CNEN3 | CNEN2 | CNEN1 | CNEN0 | 0000 | |
| 61E0 | CNPUE | 31:16 | — | — | — | — | — | — | — | — | — | — | — | CNPUE21 | CNPUE20 | CNPUE19 | CNPUE18 | CNPUE17 | CNPUE16 | 0000 |
| | | 15:0 | CNPUE15 | CNPUE14 | CNPUE13 | CNPUE12 | CNPUE11 | CNPUE10 | CNPUE9 | CNPUE8 | CNPUE7 | CNPUE6 | CNPUE5 | CNPUE4 | CNPUE3 | CNPUE2 | CNPUE1 | CNPUE0 | 0000 | |

Legend: x = unknown value on Reset, — = unimplemented, read as '0'. Reset values are shown in hexadecimal.

Note 1: All registers in this table have corresponding CLR, SET and INV registers at their virtual addresses, plus offsets of 0x4, 0x8 and 0xC, respectively. See [Section 12.1.1 “CLR, SET and INV Registers”](#) for more information.

TABLE 4-36: CHANGE NOTICE AND PULL-UP REGISTERS MAP FOR PIC32MX320F032H, PIC32MX320F064H, PIC32MX320F128H, PIC32MX340F128H, PIC32MX340F256H, PIC32MX340F512H, PIC32MX420F032H, PIC32MX440F128H, PIC32MX440F256H AND PIC32MX440F512H DEVICES ONLY⁽¹⁾

| Virtual Address (BF88_#) | Register Name | Bit Range | Bits | | | | | | | | | | | | | | | | All Resets | |
|--------------------------|---------------|-----------|---------|---------|---------|---------|---------|---------|--------|--------|--------|--------|--------|--------|--------|---------|---------|---------|------------|------|
| | | | 31/15 | 30/14 | 29/13 | 28/12 | 27/11 | 26/10 | 25/9 | 24/8 | 23/7 | 22/6 | 21/5 | 20/4 | 19/3 | 18/2 | 17/1 | 16/0 | | |
| 61C0 | CNCON | 31:16 | — | — | — | — | — | — | — | — | — | — | — | — | — | — | — | — | — | 0000 |
| | | 15:0 | ON | — | SIDL | — | — | — | — | — | — | — | — | — | — | — | — | — | — | 0000 |
| 61D0 | CNEN | 31:16 | — | — | — | — | — | — | — | — | — | — | — | — | — | CNEN18 | CNEN17 | CNEN16 | 0000 | |
| | | 15:0 | CNEN15 | CNEN14 | CNEN13 | CNEN12 | CNEN11 | CNEN10 | CNEN9 | CNEN8 | CNEN7 | CNEN6 | CNEN5 | CNEN4 | CNEN3 | CNEN2 | CNEN1 | CNEN0 | 0000 | |
| 61E0 | CNPUE | 31:16 | — | — | — | — | — | — | — | — | — | — | — | — | — | CNPUE18 | CNPUE17 | CNPUE16 | 0000 | |
| | | 15:0 | CNPUE15 | CNPUE14 | CNPUE13 | CNPUE12 | CNPUE11 | CNPUE10 | CNPUE9 | CNPUE8 | CNPUE7 | CNPUE6 | CNPUE5 | CNPUE4 | CNPUE3 | CNPUE2 | CNPUE1 | CNPUE0 | 0000 | |

Legend: x = unknown value on Reset, — = unimplemented, read as '0'. Reset values are shown in hexadecimal.

Note 1: All registers in this table have corresponding CLR, SET and INV registers at their virtual addresses, plus offsets of 0x4, 0x8 and 0xC, respectively. See [Section 12.1.1 “CLR, SET and INV Registers”](#) for more information.

TABLE 4-37: PARALLEL MASTER PORT REGISTERS MAP⁽¹⁾

| Virtual Address (BF80_#) | Register Name | Bit Range | Bits | | | | | | | | | | | | | | | All Resets | |
|--------------------------|---------------|-----------|---------------|-----------|-----------|-------------|-----------|------------|------------|------------|------|------|------|------|------|------|------|------------|------------|
| | | | 31/15 | 30/14 | 29/13 | 28/12 | 27/11 | 26/10 | 25/9 | 24/8 | 23/7 | 22/6 | 21/5 | 20/4 | 19/3 | 18/2 | 17/1 | | 16/0 |
| 7000 | PMCON | 31:16 | — | — | — | — | — | — | — | — | — | — | — | — | — | — | — | — | 0000 |
| | | 15:0 | ON | — | SIDL | ADRMUX<1:0> | PMPTTL | PTWREN | PTRDEN | CSF<1:0> | ALP | CS2P | CS1P | — | WRSP | RDSP | — | — | 0000 |
| 7010 | PMMODE | 31:16 | — | — | — | — | — | — | — | — | — | — | — | — | — | — | — | — | 0000 |
| | | 15:0 | BUSY | IRQM<1:0> | INCM<1:0> | MODE16 | MODE<1:0> | WAITB<1:0> | WAITM<3:0> | WAITE<1:0> | — | — | — | — | — | — | — | — | 0000 |
| 7020 | PMADDR | 31:16 | — | — | — | — | — | — | — | — | — | — | — | — | — | — | — | — | 0000 |
| | | 15:0 | CS2EN/A15 | CS1EN/A14 | — | — | — | — | — | — | — | — | — | — | — | — | — | — | ADDR<13:0> |
| 7030 | PMDOUT | 31:16 | DATAOUT<31:0> | | | | | | | | | | | | | | | 0000 | |
| | | 15:0 | | | | | | | | | | | | | | | | 0000 | |
| 7040 | PMDIN | 31:16 | DATAIN<31:0> | | | | | | | | | | | | | | | 0000 | |
| | | 15:0 | | | | | | | | | | | | | | | | 0000 | |
| 7050 | PMAEN | 31:16 | — | — | — | — | — | — | — | — | — | — | — | — | — | — | — | — | 0000 |
| | | 15:0 | PTEN<15:0> | | | | | | | | | | | | | | | 0000 | |
| 7060 | PMSTAT | 31:16 | — | — | — | — | — | — | — | — | — | — | — | — | — | — | — | — | 0000 |
| | | 15:0 | IBF | IBOV | — | — | IB3F | IB2F | IB1F | IB0F | OBE | OBUF | — | — | OB3E | OB2E | OB1E | OB0E | 008F |

Legend: x = unknown value on Reset, — = unimplemented, read as '0'. Reset values are shown in hexadecimal.

Note 1: All registers in this table have corresponding CLR, SET and INV registers at their virtual addresses, plus offsets of 0x4, 0x8 and 0xC, respectively. See [Section 12.1.1 “CLR, SET and INV Registers”](#) for more information.

TABLE 4-38: PROGRAMMING AND DIAGNOSTICS REGISTERS MAP

| Virtual Address (BF80_#) | Register Name | Bit Range | Bits | | | | | | | | | | | | | | | All Resets | |
|--------------------------|---------------|-----------|-------|-------|-------|-------|-------|-------|------|------|------|------|------|------|------|--------|-------|------------|------|
| | | | 31/15 | 30/14 | 29/13 | 28/12 | 27/11 | 26/10 | 25/9 | 24/8 | 23/7 | 22/6 | 21/5 | 20/4 | 19/3 | 18/2 | 17/1 | | 16/0 |
| F200 | DDPCON | 31:16 | — | — | — | — | — | — | — | — | — | — | — | — | — | — | — | — | 0000 |
| | | 15:0 | — | — | — | — | — | — | — | — | — | — | — | — | — | JTAGEN | TROEN | — | — |

Legend: x = unknown value on Reset, — = unimplemented, read as '0'. Reset values are shown in hexadecimal.

TABLE 4-39: PREFETCH REGISTERS MAP

| Virtual Address (BF88_#) | Register Name | Bit Range | Bits | | | | | | | | | | | | | | | All Resets | |
|-----------------------------|-----------------------|-----------|----------|-------|-------|-------|-------|-------|-----------|------|------|-------------|------|------|------------|------|-------------|------------|------|
| | | | 31/15 | 30/14 | 29/13 | 28/12 | 27/11 | 26/10 | 25/9 | 24/8 | 23/7 | 22/6 | 21/5 | 20/4 | 19/3 | 18/2 | 17/1 | | 16/0 |
| 4000 | CHECON ⁽¹⁾ | 31:16 | — | — | — | — | — | — | — | — | — | — | — | — | — | — | — | CHECOH | 0000 |
| | | 15:0 | — | — | — | — | — | — | DCSZ<1:0> | — | — | PREFEN<1:0> | — | — | PFMWS<2:0> | — | — | — | 0007 |
| 4010 | CHEACC ⁽¹⁾ | 31:16 | CHEWEN | — | — | — | — | — | — | — | — | — | — | — | — | — | — | 0000 | |
| | | 15:0 | — | — | — | — | — | — | — | — | — | — | — | — | — | — | CHEIDX<3:0> | 00xx | |
| 4020 | CHETAG ⁽¹⁾ | 31:16 | LTAGBOOT | — | — | — | — | — | — | — | — | — | — | — | — | — | — | xxx0 | |
| | | 15:0 | — | — | — | — | — | — | — | — | — | — | — | — | — | — | — | xxx2 | |
| 4030 | CHEMSK ⁽¹⁾ | 31:16 | — | — | — | — | — | — | — | — | — | — | — | — | — | — | — | 0000 | |
| | | 15:0 | — | — | — | — | — | — | — | — | — | — | — | — | — | — | — | xxxx | |
| 4040 | CHEW0 | 31:16 | — | — | — | — | — | — | — | — | — | — | — | — | — | — | — | xxxx | |
| | | 15:0 | — | — | — | — | — | — | — | — | — | — | — | — | — | — | — | xxxx | |
| 4050 | CHEW1 | 31:16 | — | — | — | — | — | — | — | — | — | — | — | — | — | — | — | xxxx | |
| | | 15:0 | — | — | — | — | — | — | — | — | — | — | — | — | — | — | — | xxxx | |
| 4060 | CHEW2 | 31:16 | — | — | — | — | — | — | — | — | — | — | — | — | — | — | — | xxxx | |
| | | 15:0 | — | — | — | — | — | — | — | — | — | — | — | — | — | — | — | xxxx | |
| 4070 | CHEW3 | 31:16 | — | — | — | — | — | — | — | — | — | — | — | — | — | — | — | xxxx | |
| | | 15:0 | — | — | — | — | — | — | — | — | — | — | — | — | — | — | — | xxxx | |
| 4080 | CHELRU | 31:16 | — | — | — | — | — | — | — | — | — | — | — | — | — | — | — | 0000 | |
| | | 15:0 | — | — | — | — | — | — | — | — | — | — | — | — | — | — | — | 0000 | |
| 4090 | CHEHIT | 31:16 | — | — | — | — | — | — | — | — | — | — | — | — | — | — | — | xxxx | |
| | | 15:0 | — | — | — | — | — | — | — | — | — | — | — | — | — | — | — | xxxx | |
| 40A0 | CHEMIS | 31:16 | — | — | — | — | — | — | — | — | — | — | — | — | — | — | — | xxxx | |
| | | 15:0 | — | — | — | — | — | — | — | — | — | — | — | — | — | — | — | xxxx | |
| 40C0 | CHEPFABT | 31:16 | — | — | — | — | — | — | — | — | — | — | — | — | — | — | — | xxxx | |
| | | 15:0 | — | — | — | — | — | — | — | — | — | — | — | — | — | — | — | xxxx | |

Legend: x = unknown value on Reset, — = unimplemented, read as '0'. Reset values are shown in hexadecimal.

Note 1: This register has corresponding CLR, SET and INV registers at its virtual address, plus an offset of 0x4, 0x8 and 0xC, respectively. See [Section 12.1.1 "CLR, SET and INV Registers"](#) for more information.

TABLE 4-40: RTCC REGISTERS MAP⁽¹⁾

| Virtual Address (BF80_#) | Register Name | Bit Range | Bits | | | | | | | | | | | | | | All Resets | | |
|--------------------------|---------------|-----------|-------------|-------|-------|----------|-------------|-------|------|------|--------------|----------|------|------|--------------|---------|------------|-------|------|
| | | | 31/15 | 30/14 | 29/13 | 28/12 | 27/11 | 26/10 | 25/9 | 24/8 | 23/7 | 22/6 | 21/5 | 20/4 | 19/3 | 18/2 | | 17/1 | 16/0 |
| 0200 | RTCCON | 31:16 | — | — | — | — | — | — | — | — | — | — | — | — | — | — | — | 0000 | |
| | | 15:0 | ON | — | SIDL | — | — | — | — | — | RTSECSEL | RTCCLKON | — | — | RTCWREN | RTCSYNC | HALFSEC | RTCOE | 0000 |
| 0210 | RTCALRM | 31:16 | — | — | — | — | — | — | — | — | — | — | — | — | — | — | — | 0000 | |
| | | 15:0 | ALRMEN | CHIME | PIV | ALRMSYNC | AMASK<3:0> | | | | ARPT<7:0> | | | | | | | 0000 | |
| 0220 | RTCTIME | 31:16 | HR10<3:0> | | | | HR01<3:0> | | | | MIN10<3:0> | | | | MIN01<3:0> | | | | xxxx |
| | | 15:0 | SEC10<3:0> | | | | SEC01<3:0> | | | | — | — | — | — | — | — | — | — | xx00 |
| 0230 | RTCDATE | 31:16 | YEAR10<3:0> | | | | YEAR01<3:0> | | | | MONTH10<3:0> | | | | MONTH01<3:0> | | | | xxxx |
| | | 15:0 | DAY10<3:0> | | | | DAY01<3:0> | | | | — | — | — | — | WDAY01<3:0> | | | | xx0x |
| 0240 | ALRMTIME | 31:16 | MIN10<3:0> | | | | MIN01<3:0> | | | | MIN10<3:0> | | | | MIN01<3:0> | | | | xxxx |
| | | 15:0 | SEC10<3:0> | | | | SEC01<3:0> | | | | — | — | — | — | — | — | — | — | xx00 |
| 0250 | ALRMDATE | 31:16 | — | — | — | — | — | — | — | — | — | — | — | — | — | — | — | 00xx | |
| | | 15:0 | DAY10<3:0> | | | | DAY01<3:0> | | | | — | — | — | — | WDAY01<3:0> | | | | xx0x |

Legend: x = unknown value on Reset, — = unimplemented, read as '0'. Reset values are shown in hexadecimal.

Note 1: All registers in this table have corresponding CLR, SET and INV registers at their virtual addresses, plus offsets of 0x4, 0x8 and 0xC, respectively. See [Section 12.1.1 “CLR, SET and INV Registers”](#) for more information.

TABLE 4-41: DEVCFG: DEVICE CONFIGURATION WORD SUMMARY

| Virtual Address (BFC0_#) | Register Name | Bit Range | Bits | | | | | | | | | | | | | | All Resets | | |
|--------------------------|---------------|-----------|-----------------------|----------|-------------|----------|----------|-----------------------------|--------------|---------|---------|---------|--------------|------------|---------------|---------------|------------|------------|------|
| | | | 31/15 | 30/14 | 29/13 | 28/12 | 27/11 | 26/10 | 25/9 | 24/8 | 23/7 | 22/6 | 21/5 | 20/4 | 19/3 | 18/2 | | 17/1 | 16/0 |
| 2FF0 | DEVCFG3 | 31:16 | — | — | — | — | — | — | — | — | — | — | — | — | — | — | — | xxxx | |
| | | 15:0 | USERID15 | USERID14 | USERID13 | USERID12 | USERID11 | USERID10 | USERID9 | USERID8 | USERID7 | USERID6 | USERID5 | USERID4 | USERID3 | USERID2 | USERID1 | USERID0 | xxxx |
| 2FF4 | DEVCFG2 | 31:16 | — | — | — | — | — | — | — | — | — | — | — | — | FPLLIDIV<2:0> | | | xxxx | |
| | | 15:0 | UPLLEN ⁽¹⁾ | — | — | — | — | UPLLDIV<2:0> ⁽¹⁾ | | | | — | FPLLMUL<2:0> | | | FPLLIDIV<2:0> | | xxxx | |
| 2FF8 | DEVCFG1 | 31:16 | — | — | — | — | — | — | — | — | FWDTEN | — | — | WDTPS<4:0> | | | | xxxx | |
| | | 15:0 | FCKSM<1:0> | | FPBDIV<1:0> | | — | OSCI0FNC | POSCMOD<1:0> | | IESO | — | FSOSCEN | — | — | FNOSC<2:0> | | | xxxx |
| 2FFC | DEVCFG0 | 31:16 | — | — | — | CP | — | — | — | BWP | — | — | — | — | PWP19 | PWP18 | PWP17 | PWP16 | xxxx |
| | | 15:0 | PWP15 | PWP14 | PWP13 | PWP12 | — | — | — | — | — | — | — | — | — | ICSEL | — | DEBUG<1:0> | |

Legend: x = unknown value on Reset, — = unimplemented, read as '0'. Reset values are shown in hexadecimal.

Note 1: These bits are only available on PIC32MX4XX devices.

TABLE 4-42: DEVICE AND REVISION ID SUMMARY

| Virtual Address (BF80_#) | Register Name | Bit Range | Bits | | | | | | | | | | | | | | All Resets | | |
|-----------------------------|------------------|-----------|-------------|-------|-------|-------|-------|--------------|------|------|------|------|------|------|------|------|------------|------|------|
| | | | 31/15 | 30/14 | 29/13 | 28/12 | 27/11 | 26/10 | 25/9 | 24/8 | 23/7 | 22/6 | 21/5 | 20/4 | 19/3 | 18/2 | | 17/1 | 16/0 |
| F220 | DEVID | 31:16 | VER<3:0> | | | | | DEVID<27:16> | | | | | | | | | | | xxxx |
| | | 15:0 | DEVID<15:0> | | | | | | | | | | | | | | xxxx | | |

Legend: x = unknown value on Reset, — = unimplemented, read as '0'. Reset values are shown in hexadecimal.

TABLE 4-43: USB REGISTERS MAP⁽¹⁾

| Virtual Address (BF88.#) | Register Name | Bit Range | Bits | | | | | | | | | | | | | | | | All Resets | | |
|--------------------------|---------------------------|-----------|-------|-------|-------|-------|-------|-------|------|------|------|---------------------------|--------------------|----------|----------|---------|----------|----------|------------|-------|------|
| | | | 31/15 | 30/14 | 29/13 | 28/12 | 27/11 | 26/10 | 25/9 | 24/8 | 23/7 | 22/6 | 21/5 | 20/4 | 19/3 | 18/2 | 17/1 | 16/0 | | | |
| 5040 | U1OTG IR ⁽²⁾ | 31:16 | — | — | — | — | — | — | — | — | — | — | — | — | — | — | — | — | — | — | 0000 |
| | | 15:0 | — | — | — | — | — | — | — | — | — | IDIF | T1MSECIF | LSTATEIF | ACTVIF | SESVDIF | SESENDIF | — | VBUSVDIF | 0000 | |
| 5050 | U1OTG IE | 31:16 | — | — | — | — | — | — | — | — | — | — | — | — | — | — | — | — | — | — | 0000 |
| | | 15:0 | — | — | — | — | — | — | — | — | — | IDIE | T1MSECIE | LSTATEIE | ACTVIE | SESVDIE | SESENDIE | — | VBUSVDIE | 0000 | |
| 5060 | U1OTG STAT ⁽³⁾ | 31:16 | — | — | — | — | — | — | — | — | — | — | — | — | — | — | — | — | — | — | 0000 |
| | | 15:0 | — | — | — | — | — | — | — | — | — | ID | — | LSTATE | — | SESVD | SESEND | — | VBUSVD | 0000 | |
| 5070 | U1OTG CON | 31:16 | — | — | — | — | — | — | — | — | — | — | — | — | — | — | — | — | — | — | 0000 |
| | | 15:0 | — | — | — | — | — | — | — | — | — | DPPULUP | DMPULUP | DPPULDWN | DMPULDWN | VBUSON | OTGEN | VBUSCHG | VBUSDIS | 0000 | |
| 5080 | U1PWRC | 31:16 | — | — | — | — | — | — | — | — | — | — | — | — | — | — | — | — | — | — | 0000 |
| | | 15:0 | — | — | — | — | — | — | — | — | — | UACTPND ⁽⁴⁾ | — | — | USLPGRD | — | — | USUSPEND | USBPWR | 0000 | |
| 5200 | U1IR ⁽²⁾ | 31:16 | — | — | — | — | — | — | — | — | — | — | — | — | — | — | — | — | — | — | 0000 |
| | | 15:0 | — | — | — | — | — | — | — | — | — | STALLIF | ATTACHIF | RESUMEIF | IDLEIF | TRNIF | SOFIF | UERRIF | URSTIF | 0000 | |
| 5210 | U1IE | 31:16 | — | — | — | — | — | — | — | — | — | — | — | — | — | — | — | — | — | — | 0000 |
| | | 15:0 | — | — | — | — | — | — | — | — | — | STALLIE | ATTACHIE | RESUMEIE | IDLEIE | TRNIE | SOFIE | UERRIE | URSTIE | 0000 | |
| 5220 | U1EIR | 31:16 | — | — | — | — | — | — | — | — | — | — | — | — | — | — | — | — | — | — | 0000 |
| | | 15:0 | — | — | — | — | — | — | — | — | — | BTSEF | BMXEF | DMAEF | BTOEF | DFN8EF | CRC16EF | CRC5EF | EOFEF | PIDEF | 0000 |
| 5230 | U1EIE | 31:16 | — | — | — | — | — | — | — | — | — | — | — | — | — | — | — | — | — | — | 0000 |
| | | 15:0 | — | — | — | — | — | — | — | — | — | BTSEE | BMXEE | DMAEE | BTOEE | DFN8EE | CRC16EE | CRC5EE | EOFEE | PIDEE | 0000 |
| 5240 | U1STAT ⁽³⁾ | 31:16 | — | — | — | — | — | — | — | — | — | — | — | — | — | — | — | — | — | — | 0000 |
| | | 15:0 | — | — | — | — | — | — | — | — | — | ENDPT<3:0> ⁽⁴⁾ | | | | | DIR | PPBI | — | — | 0000 |
| 5250 | U1CON | 31:16 | — | — | — | — | — | — | — | — | — | — | — | — | — | — | — | — | — | — | 0000 |
| | | 15:0 | — | — | — | — | — | — | — | — | — | JSTATE ⁽⁴⁾ | SE0 ⁽⁴⁾ | PKTDIS | USBRST | HOSTEN | RESUME | PPBRST | USBEN | 0000 | |
| 5260 | U1ADDR | 31:16 | — | — | — | — | — | — | — | — | — | — | — | — | — | — | — | — | — | — | 0000 |
| | | 15:0 | — | — | — | — | — | — | — | — | — | LSPDEN | DEVADDR<6:0> | | | | | | | | 0000 |
| 5270 | U1BDTP1 | 31:16 | — | — | — | — | — | — | — | — | — | — | — | — | — | — | — | — | — | — | 0000 |
| | | 15:0 | — | — | — | — | — | — | — | — | — | BDTPTRL<7:1> | | | | | | | | 0000 | |

Legend: x = unknown value on Reset, — = unimplemented, read as '0'. Reset values are shown in hexadecimal.

- Note 1:** Except where noted, all registers in this table have corresponding CLR, SET and INV registers at their virtual addresses, plus offsets of 0x4, 0x8 and 0xC, respectively. See [Section 12.1.1 "CLR, SET and INV Registers"](#) for more information.
- 2:** This register does not have associated CLR, SET, and INV registers.
- 3:** All bits in this register are read-only; therefore, CLR, SET, and INV registers are not supported.
- 4:** The reset value for this bit is undefined.

TABLE 4-43: USB REGISTERS MAP⁽¹⁾ (CONTINUED)

| Virtual Address (BF68_#) | Register Name | Bit Range | Bits | | | | | | | | | | | | | | | | All Resets |
|--------------------------|-----------------------|-----------|-------|-------|-------|-------|-------|-------|------|--------------|----------|--------|----------|---------|------------|---------|--------|------|------------|
| | | | 31/15 | 30/14 | 29/13 | 28/12 | 27/11 | 26/10 | 25/9 | 24/8 | 23/7 | 22/6 | 21/5 | 20/4 | 19/3 | 18/2 | 17/1 | 16/0 | |
| 5280 | U1FRML ⁽³⁾ | 31:16 | — | — | — | — | — | — | — | — | — | — | — | — | — | — | — | — | 0000 |
| | | 15:0 | — | — | — | — | — | — | — | FRML<7:0> | | | | | | | | 0000 | |
| 5290 | U1FRMH ⁽³⁾ | 31:16 | — | — | — | — | — | — | — | — | — | — | — | — | — | — | — | — | 0000 |
| | | 15:0 | — | — | — | — | — | — | — | — | — | — | — | — | FRMH<10:8> | | | | 0000 |
| 52A0 | U1TOK | 31:16 | — | — | — | — | — | — | — | — | — | — | — | — | — | — | — | — | 0000 |
| | | 15:0 | — | — | — | — | — | — | — | PID<3:0> | | | | EP<3:0> | | | | 0000 | |
| 52B0 | U1SOF | 31:16 | — | — | — | — | — | — | — | — | — | — | — | — | — | — | — | — | 0000 |
| | | 15:0 | — | — | — | — | — | — | — | CNT<7:0> | | | | | | | | 0000 | |
| 52C0 | U1BDTP2 | 31:16 | — | — | — | — | — | — | — | — | — | — | — | — | — | — | — | — | 0000 |
| | | 15:0 | — | — | — | — | — | — | — | BDTPTRH<7:0> | | | | | | | | 0000 | |
| 52D0 | U1BDTP3 | 31:16 | — | — | — | — | — | — | — | — | — | — | — | — | — | — | — | — | 0000 |
| | | 15:0 | — | — | — | — | — | — | — | BDTPTRU<7:0> | | | | | | | | 0000 | |
| 52E0 | U1CNFG1 | 31:16 | — | — | — | — | — | — | — | — | — | — | — | — | — | — | — | — | 0000 |
| | | 15:0 | — | — | — | — | — | — | — | UTEYE | UOEMON | USBFRZ | USBSIDL | — | — | — | — | — | 0000 |
| 5300 | U1EP0 | 31:16 | — | — | — | — | — | — | — | — | — | — | — | — | — | — | — | — | 0000 |
| | | 15:0 | — | — | — | — | — | — | — | LSPD | RETRYDIS | — | EPCONDIS | EPRXEN | EPTXEN | EPSTALL | EPHSHK | 0000 | |
| 5310 | U1EP1 | 31:16 | — | — | — | — | — | — | — | — | — | — | — | — | — | — | — | — | 0000 |
| | | 15:0 | — | — | — | — | — | — | — | — | — | — | EPCONDIS | EPRXEN | EPTXEN | EPSTALL | EPHSHK | 0000 | |
| 5320 | U1EP2 | 31:16 | — | — | — | — | — | — | — | — | — | — | — | — | — | — | — | — | 0000 |
| | | 15:0 | — | — | — | — | — | — | — | — | — | — | EPCONDIS | EPRXEN | EPTXEN | EPSTALL | EPHSHK | 0000 | |
| 5330 | U1EP3 | 31:16 | — | — | — | — | — | — | — | — | — | — | — | — | — | — | — | — | 0000 |
| | | 15:0 | — | — | — | — | — | — | — | — | — | — | EPCONDIS | EPRXEN | EPTXEN | EPSTALL | EPHSHK | 0000 | |
| 5340 | U1EP4 | 31:16 | — | — | — | — | — | — | — | — | — | — | — | — | — | — | — | — | 0000 |
| | | 15:0 | — | — | — | — | — | — | — | — | — | — | EPCONDIS | EPRXEN | EPTXEN | EPSTALL | EPHSHK | 0000 | |
| 5350 | U1EP5 | 31:16 | — | — | — | — | — | — | — | — | — | — | — | — | — | — | — | — | 0000 |
| | | 15:0 | — | — | — | — | — | — | — | — | — | — | EPCONDIS | EPRXEN | EPTXEN | EPSTALL | EPHSHK | 0000 | |
| 5360 | U1EP6 | 31:16 | — | — | — | — | — | — | — | — | — | — | — | — | — | — | — | — | 0000 |
| | | 15:0 | — | — | — | — | — | — | — | — | — | — | EPCONDIS | EPRXEN | EPTXEN | EPSTALL | EPHSHK | 0000 | |
| 5370 | U1EP7 | 31:16 | — | — | — | — | — | — | — | — | — | — | — | — | — | — | — | — | 0000 |
| | | 15:0 | — | — | — | — | — | — | — | — | — | — | EPCONDIS | EPRXEN | EPTXEN | EPSTALL | EPHSHK | 0000 | |

Legend: x = unknown value on Reset, — = unimplemented, read as '0'. Reset values are shown in hexadecimal.

Note 1: Except where noted, all registers in this table have corresponding CLR, SET and INV registers at their virtual addresses, plus offsets of 0x4, 0x8 and 0xC, respectively. See [Section 12.1.1 “CLR, SET and INV Registers”](#) for more information.

- 2:** This register does not have associated CLR, SET, and INV registers.
- 3:** All bits in this register are read-only; therefore, CLR, SET, and INV registers are not supported.
- 4:** The reset value for this bit is undefined.

TABLE 4-43: USB REGISTERS MAP⁽¹⁾ (CONTINUED)

| Virtual Address (BF88_#) | Register Name | Bit Range | Bits | | | | | | | | | | | | | | | | All Resets |
|-----------------------------|------------------|--------------|-------|-------|-------|-------|-------|-------|------|------|------|------|------|------|----------|--------|--------|---------|---------------|
| | | | 31/15 | 30/14 | 29/13 | 28/12 | 27/11 | 26/10 | 25/9 | 24/8 | 23/7 | 22/6 | 21/5 | 20/4 | 19/3 | 18/2 | 17/1 | 16/0 | |
| 5380 | U1EP8 | 31:16 | — | — | — | — | — | — | — | — | — | — | — | — | — | — | — | — | 0000 |
| | | 15:0 | — | — | — | — | — | — | — | — | — | — | — | — | EPCONDIS | EPRXEN | EPTXEN | EPSTALL | EPHSHK |
| 5390 | U1EP9 | 31:16 | — | — | — | — | — | — | — | — | — | — | — | — | — | — | — | — | 0000 |
| | | 15:0 | — | — | — | — | — | — | — | — | — | — | — | — | EPCONDIS | EPRXEN | EPTXEN | EPSTALL | EPHSHK |
| 53A0 | U1EP10 | 31:16 | — | — | — | — | — | — | — | — | — | — | — | — | — | — | — | — | 0000 |
| | | 15:0 | — | — | — | — | — | — | — | — | — | — | — | — | EPCONDIS | EPRXEN | EPTXEN | EPSTALL | EPHSHK |
| 53B0 | U1EP11 | 31:16 | — | — | — | — | — | — | — | — | — | — | — | — | — | — | — | — | 0000 |
| | | 15:0 | — | — | — | — | — | — | — | — | — | — | — | — | EPCONDIS | EPRXEN | EPTXEN | EPSTALL | EPHSHK |
| 53C0 | U1EP12 | 31:16 | — | — | — | — | — | — | — | — | — | — | — | — | — | — | — | — | 0000 |
| | | 15:0 | — | — | — | — | — | — | — | — | — | — | — | — | EPCONDIS | EPRXEN | EPTXEN | EPSTALL | EPHSHK |
| 53D0 | U1EP13 | 31:16 | — | — | — | — | — | — | — | — | — | — | — | — | — | — | — | — | 0000 |
| | | 15:0 | — | — | — | — | — | — | — | — | — | — | — | — | EPCONDIS | EPRXEN | EPTXEN | EPSTALL | EPHSHK |
| 53E0 | U1EP14 | 31:16 | — | — | — | — | — | — | — | — | — | — | — | — | — | — | — | — | 0000 |
| | | 15:0 | — | — | — | — | — | — | — | — | — | — | — | — | EPCONDIS | EPRXEN | EPTXEN | EPSTALL | EPHSHK |
| 53F0 | U1EP15 | 31:16 | — | — | — | — | — | — | — | — | — | — | — | — | — | — | — | — | 0000 |
| | | 15:0 | — | — | — | — | — | — | — | — | — | — | — | — | EPCONDIS | EPRXEN | EPTXEN | EPSTALL | EPHSHK |

Legend: x = unknown value on Reset, — = unimplemented, read as '0'. Reset values are shown in hexadecimal.

Note 1: Except where noted, all registers in this table have corresponding CLR, SET and INV registers at their virtual addresses, plus offsets of 0x4, 0x8 and 0xC, respectively. See [Section 12.1.1 “CLR, SET and INV Registers”](#) for more information.

2: This register does not have associated CLR, SET, and INV registers.

3: All bits in this register are read-only; therefore, CLR, SET, and INV registers are not supported.

4: The reset value for this bit is undefined.

5.0 FLASH PROGRAM MEMORY

Note 1: This data sheet summarizes the features of the PIC32MX3XX/4XX family of devices. It is not intended to be a comprehensive reference source. To complement the information in this data sheet, refer to **Section 5. “Flash Program Memory”** (DS61121) of the *“PIC32 Family Reference Manual”*, which is available from the Microchip web site (www.microchip.com/PIC32).

2: Some registers and associated bits described in this section may not be available on all devices. Refer to **Section 4.0 “Memory Organization”** in this data sheet for device-specific register and bit information.

RTSP is performed by software executing from either Flash or RAM memory. EJTAG is performed using the EJTAG port of the device and a EJTAG capable programmer. ICSP is performed using a serial data connection to the device and allows much faster programming times than RTSP. RTSP techniques are described in this chapter. The ICSP and EJTAG methods are described in the *“PIC32MX Flash Programming Specification”* (DS61145), which can be downloaded from the Microchip web site.

Note: Flash LVD Delay (LVDstartup) must be taken into account between setting up and executing any Flash command operation. See [Example 5-1](#) for a code example to set up and execute a Flash command operation.

PIC32MX3XX/4XX devices contain an internal program Flash memory for executing user code. There are three methods by which the user can program this memory:

- Run-Time Self Programming (RTSP)
- In-Circuit Serial Programming™ (ICSP™)
- EJTAG Programming

EXAMPLE 5-1:

```
NVMCON = 0x4004;           // Enable and configure for erase operation
Wait(delay);              // Delay for 6 µs for LVDstartup

NVMKEY = 0xAA996655;
NVMKEY = 0x556699AA;
NVMCONSET = 0x8000;       // Initiate operation

while(NVMCONbits.WR==1); // Wait for current operation to complete
```

PIC32MX3XX/4XX

NOTES:

6.0 RESETS

Note 1: This data sheet summarizes the features of the PIC32MX3XX/4XX family of devices. It is not intended to be a comprehensive reference source. To complement the information in this data sheet, refer to **Section 7. “Resets”** (DS61118) of the *“PIC32 Family Reference Manual”*, which is available from the Microchip web site (www.microchip.com/PIC32).

2: Some registers and associated bits described in this section may not be available on all devices. Refer to **Section 4.0 “Memory Organization”** in this data sheet for device-specific register and bit information.

The Reset module combines all Reset sources and controls the device Master Reset signal, SYSRST. The following is a list of device Reset sources:

- POR: Power-on Reset
- MCLR: Master Clear Reset Pin
- SWR: Software Reset
- WDTR: Watchdog Timer Reset
- BOR: Brown-out Reset
- CMR: Configuration Mismatch Reset

A simplified block diagram of the Reset module is illustrated in [Figure 6-1](#).

FIGURE 6-1: SYSTEM RESET BLOCK DIAGRAM

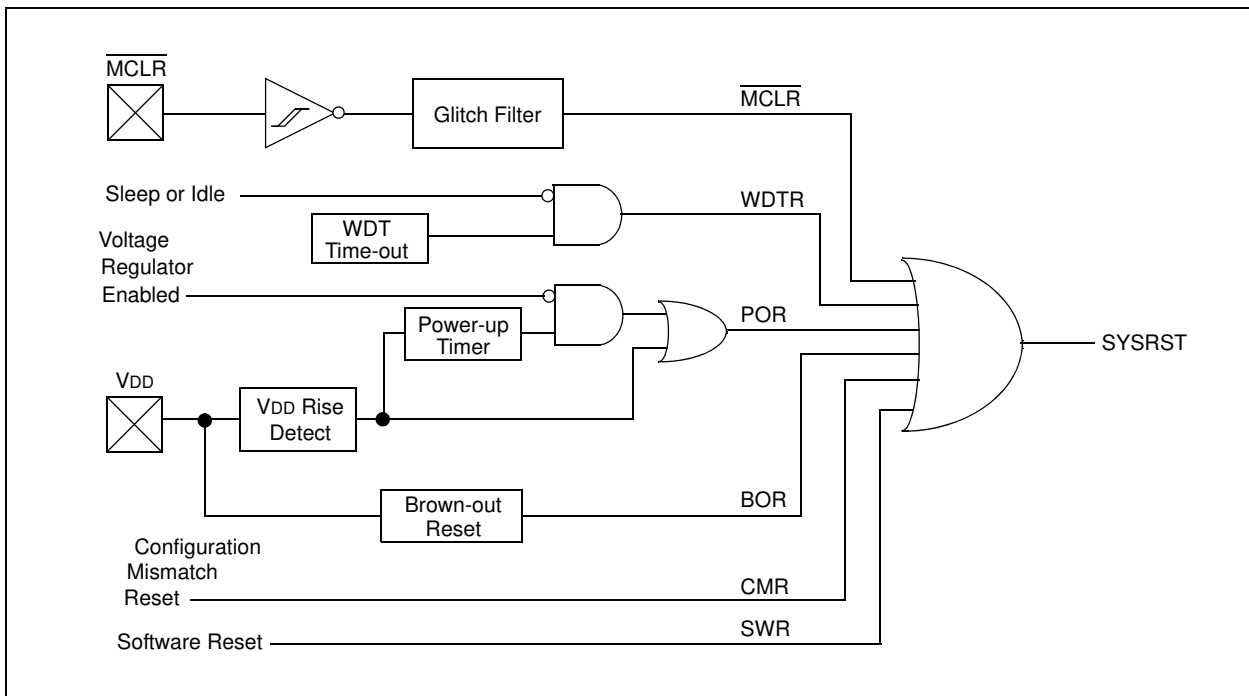

PIC32MX3XX/4XX

NOTES:

7.0 INTERRUPT CONTROLLER

Note 1: This data sheet summarizes the features of the PIC32MX3XX/4XX family of devices. It is not intended to be a comprehensive reference source. To complement the information in this data sheet, refer to **Section 8. “Interrupt Controller”** (DS61108) of the “PIC32 Family Reference Manual”, which is available from the Microchip web site (www.microchip.com/PIC32).

2: Some registers and associated bits described in this section may not be available on all devices. Refer to **Section 4.0 “Memory Organization”** in this data sheet for device-specific register and bit information.

PIC32MX3XX/4XX devices generate interrupt requests in response to interrupt events from peripheral modules. The Interrupt Control module exists externally to the CPU logic and prioritizes the interrupt events before presenting them to the CPU.

The PIC32MX3XX/4XX interrupts module includes the following features:

- Up to 96 interrupt sources
- Up to 64 interrupt vectors
- Single and Multi-Vector mode operations
- Five external interrupts with edge polarity control
- Interrupt proximity timer
- Module Freeze in Debug mode
- Seven user-selectable priority levels for each vector
- Four user-selectable subpriority levels within each priority
- Dedicated shadow set for highest priority level
- Software can generate any interrupt
- User-configurable interrupt vector table location
- User-configurable interrupt vector spacing

FIGURE 7-1: INTERRUPT CONTROLLER MODULE

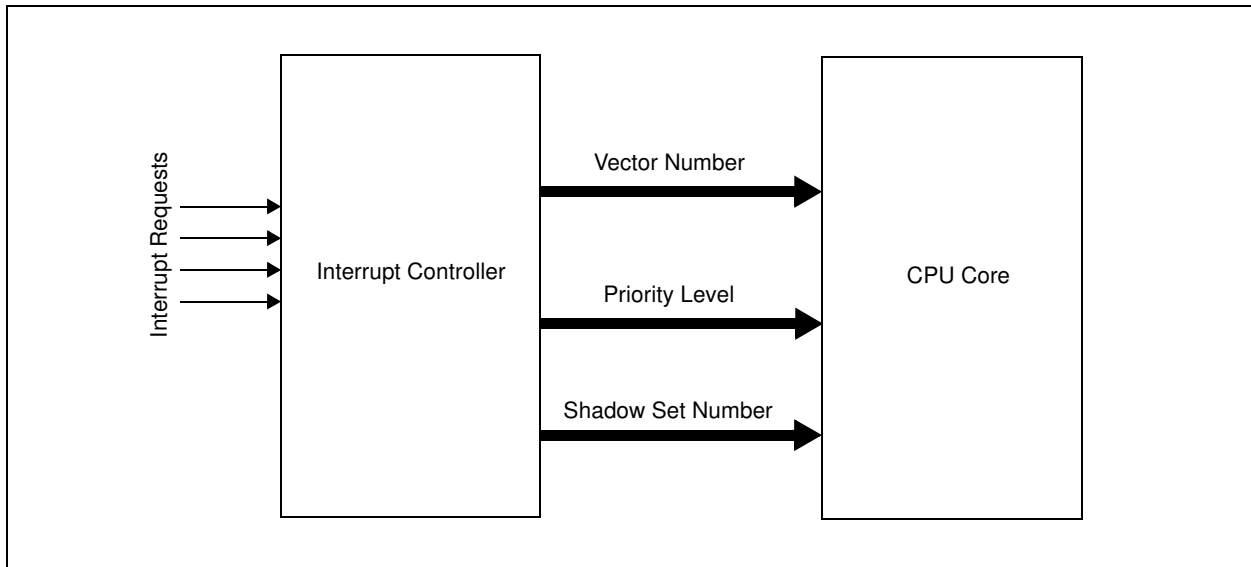

Note: Several of the registers cited in this section are not in the interrupt controller module. These registers (and bits) are associated with the CPU. Details about them are available in **Section 3.0 “CPU”**.

To avoid confusion, a typographic distinction is made for registers in the CPU. The register names in this section, and all other sections of this manual, are signified by uppercase letters only. The CPU register names are signified by upper and lowercase letters. For example, INTSTAT is an Interrupts register; whereas, IntCtl is a CPU register.

PIC32MX3XX/4XX

TABLE 7-1: INTERRUPT IRQ AND VECTOR LOCATION

| Interrupt Source ⁽¹⁾ | IRQ | Vector Number | Interrupt Bit Location | | | |
|----------------------------------|-----|---------------|------------------------|----------|-------------|-------------|
| | | | Flag | Enable | Priority | Subpriority |
| Highest Natural Order Priority | | | | | | |
| CT – Core Timer Interrupt | 0 | 0 | IFS0<0> | IEC0<0> | IPC0<4:2> | IPC0<1:0> |
| CS0 – Core Software Interrupt 0 | 1 | 1 | IFS0<1> | IEC0<1> | IPC0<12:10> | IPC0<9:8> |
| CS1 – Core Software Interrupt 1 | 2 | 2 | IFS0<2> | IEC0<2> | IPC0<20:18> | IPC0<17:16> |
| INT0 – External Interrupt 0 | 3 | 3 | IFS0<3> | IEC0<3> | IPC0<28:26> | IPC0<25:24> |
| T1 – Timer1 | 4 | 4 | IFS0<4> | IEC0<4> | IPC1<4:2> | IPC1<1:0> |
| IC1 – Input Capture 1 | 5 | 5 | IFS0<5> | IEC0<5> | IPC1<12:10> | IPC1<9:8> |
| OC1 – Output Compare 1 | 6 | 6 | IFS0<6> | IEC0<6> | IPC1<20:18> | IPC1<17:16> |
| INT1 – External Interrupt 1 | 7 | 7 | IFS0<7> | IEC0<7> | IPC1<28:26> | IPC1<25:24> |
| T2 – Timer2 | 8 | 8 | IFS0<8> | IEC0<8> | IPC2<4:2> | IPC2<1:0> |
| IC2 – Input Capture 2 | 9 | 9 | IFS0<9> | IEC0<9> | IPC2<12:10> | IPC2<9:8> |
| OC2 – Output Compare 2 | 10 | 10 | IFS0<10> | IEC0<10> | IPC2<20:18> | IPC2<17:16> |
| INT2 – External Interrupt 2 | 11 | 11 | IFS0<11> | IEC0<11> | IPC2<28:26> | IPC2<25:24> |
| T3 – Timer3 | 12 | 12 | IFS0<12> | IEC0<12> | IPC3<4:2> | IPC3<1:0> |
| IC3 – Input Capture 3 | 13 | 13 | IFS0<13> | IEC0<13> | IPC3<12:10> | IPC3<9:8> |
| OC3 – Output Compare 3 | 14 | 14 | IFS0<14> | IEC0<14> | IPC3<20:18> | IPC3<17:16> |
| INT3 – External Interrupt 3 | 15 | 15 | IFS0<15> | IEC0<15> | IPC3<28:26> | IPC3<25:24> |
| T4 – Timer4 | 16 | 16 | IFS0<16> | IEC0<16> | IPC4<4:2> | IPC4<1:0> |
| IC4 – Input Capture 4 | 17 | 17 | IFS0<17> | IEC0<17> | IPC4<12:10> | IPC4<9:8> |
| OC4 – Output Compare 4 | 18 | 18 | IFS0<18> | IEC0<18> | IPC4<20:18> | IPC4<17:16> |
| INT4 – External Interrupt 4 | 19 | 19 | IFS0<19> | IEC0<19> | IPC4<28:26> | IPC4<25:24> |
| T5 – Timer5 | 20 | 20 | IFS0<20> | IEC0<20> | IPC5<4:2> | IPC5<1:0> |
| IC5 – Input Capture 5 | 21 | 21 | IFS0<21> | IEC0<21> | IPC5<12:10> | IPC5<9:8> |
| OC5 – Output Compare 5 | 22 | 22 | IFS0<22> | IEC0<22> | IPC5<20:18> | IPC5<17:16> |
| SPI1E – SPI1 Fault | 23 | 23 | IFS0<23> | IEC0<23> | IPC5<28:26> | IPC5<25:24> |
| SPI1TX – SPI1 Transfer Done | 24 | 23 | IFS0<24> | IEC0<24> | IPC5<28:26> | IPC5<25:24> |
| SPI1RX – SPI1 Receive Done | 25 | 23 | IFS0<25> | IEC0<25> | IPC5<28:26> | IPC5<25:24> |
| U1E – UART1 Error | 26 | 24 | IFS0<26> | IEC0<26> | IPC6<4:2> | IPC6<1:0> |
| U1RX – UART1 Receiver | 27 | 24 | IFS0<27> | IEC0<27> | IPC6<4:2> | IPC6<1:0> |
| U1TX – UART1 Transmitter | 28 | 24 | IFS0<28> | IEC0<28> | IPC6<4:2> | IPC6<1:0> |
| I2C1B – I2C1 Bus Collision Event | 29 | 25 | IFS0<29> | IEC0<29> | IPC6<12:10> | IPC6<9:8> |
| I2C1S – I2C1 Slave Event | 30 | 25 | IFS0<30> | IEC0<30> | IPC6<12:10> | IPC6<9:8> |
| I2C1M – I2C1 Master Event | 31 | 25 | IFS0<31> | IEC0<31> | IPC6<12:10> | IPC6<9:8> |
| CN – Input Change Interrupt | 32 | 26 | IFS1<0> | IEC1<0> | IPC6<20:18> | IPC6<17:16> |
| AD1 – ADC1 Convert Done | 33 | 27 | IFS1<1> | IEC1<1> | IPC6<28:26> | IPC6<25:24> |
| PMP – Parallel Master Port | 34 | 28 | IFS1<2> | IEC1<2> | IPC7<4:2> | IPC7<1:0> |
| CMP1 – Comparator Interrupt | 35 | 29 | IFS1<3> | IEC1<3> | IPC7<12:10> | IPC7<9:8> |
| CMP2 – Comparator Interrupt | 36 | 30 | IFS1<4> | IEC1<4> | IPC7<20:18> | IPC7<17:16> |

Note 1: Not all interrupt sources are available on all devices. See [TABLE 1: “PIC32MX General Purpose – Features”](#) and [TABLE 2: “PIC32MX USB – Features”](#) for available peripherals.

TABLE 7-1: INTERRUPT IRQ AND VECTOR LOCATION (CONTINUED)

| Interrupt Source ⁽¹⁾ | IRQ | Vector Number | Interrupt Bit Location | | | |
|-------------------------------------|-----|---------------|------------------------|----------|--------------|-------------|
| | | | Flag | Enable | Priority | Subpriority |
| Highest Natural Order Priority | | | | | | |
| SPI2E – SPI2 Fault | 37 | 31 | IFS1<5> | IEC1<5> | IPC7<28:26> | IPC7<25:24> |
| SPI2TX – SPI2 Transfer Done | 38 | 31 | IFS1<6> | IEC1<6> | IPC7<28:26> | IPC7<25:24> |
| SPI2RX – SPI2 Receive Done | 39 | 31 | IFS1<7> | IEC1<7> | IPC7<28:26> | IPC7<25:24> |
| U2E – UART2 Error | 40 | 32 | IFS1<8> | IEC1<8> | IPC8<4:2> | IPC8<1:0> |
| U2RX – UART2 Receiver | 41 | 32 | IFS1<9> | IEC1<9> | IPC8<4:2> | IPC8<1:0> |
| U2TX – UART2 Transmitter | 42 | 32 | IFS1<10> | IEC1<10> | IPC8<4:2> | IPC8<1:0> |
| I2C2B – I2C2 Bus Collision Event | 43 | 33 | IFS1<11> | IEC1<11> | IPC8<12:10> | IPC8<9:8> |
| I2C2S – I2C2 Slave Event | 44 | 33 | IFS1<12> | IEC1<12> | IPC8<12:10> | IPC8<9:8> |
| I2C2M – I2C2 Master Event | 45 | 33 | IFS1<13> | IEC1<13> | IPC8<12:10> | IPC8<9:8> |
| FSCM – Fail-Safe Clock Monitor | 46 | 34 | IFS1<14> | IEC1<14> | IPC8<20:18> | IPC8<17:16> |
| RTCC – Real-Time Clock and Calendar | 47 | 35 | IFS1<15> | IEC1<15> | IPC8<28:26> | IPC8<25:24> |
| DMA0 – DMA Channel 0 | 48 | 36 | IFS1<16> | IEC1<16> | IPC9<4:2> | IPC9<1:0> |
| DMA1 – DMA Channel 1 | 49 | 37 | IFS1<17> | IEC1<17> | IPC9<12:10> | IPC9<9:8> |
| DMA2 – DMA Channel 2 | 50 | 38 | IFS1<18> | IEC1<18> | IPC9<20:18> | IPC9<17:16> |
| DMA3 – DMA Channel 3 | 51 | 39 | IFS1<19> | IEC1<19> | IPC9<28:26> | IPC9<25:24> |
| FCE – Flash Control Event | 56 | 44 | IFS1<24> | IEC1<24> | IPC11<4:2> | IPC11<1:0> |
| USB | 57 | 45 | IFS1<25> | IEC1<25> | IPC11<12:10> | IPC11<9:8> |
| Lowest Natural Order Priority | | | | | | |

Note 1: Not all interrupt sources are available on all devices. See [TABLE 1: “PIC32MX General Purpose – Features”](#) and [TABLE 2: “PIC32MX USB – Features”](#) for available peripherals.

PIC32MX3XX/4XX

NOTES:

8.0 OSCILLATOR CONFIGURATION

Note 1: This data sheet summarizes the features of the PIC32MX3XX/4XX family of devices. It is not intended to be a comprehensive reference source. To complement the information in this data sheet, refer to the “PIC32 Family Reference Manual” **Section 6. “Oscillator Configuration”** (DS61112), which is available from the Microchip web site (www.microchip.com/PIC32).

2: Some registers and associated bits described in this section may not be available on all devices. Refer to **Section 4.0 “Memory Organization”** in this data sheet for device-specific register and bit information.

The PIC32MX oscillator system has the following modules and features:

- A total of four external and internal oscillator options as clock sources
- On-chip PLL (phase-locked loop) with user-selectable input divider, multiplier and output divider to boost operating frequency on select internal and external oscillator sources
- On-chip user-selectable divisor postscaler on select oscillator sources
- Software-controllable switching between various clock sources
- A Fail-Safe Clock Monitor (FSCM) that detects clock failure and permits safe application recovery or shut down
- Dedicated on-chip PLL for USB peripheral

FIGURE 8-1: PIC32MX3XX/4XX FAMILY CLOCK DIAGRAM

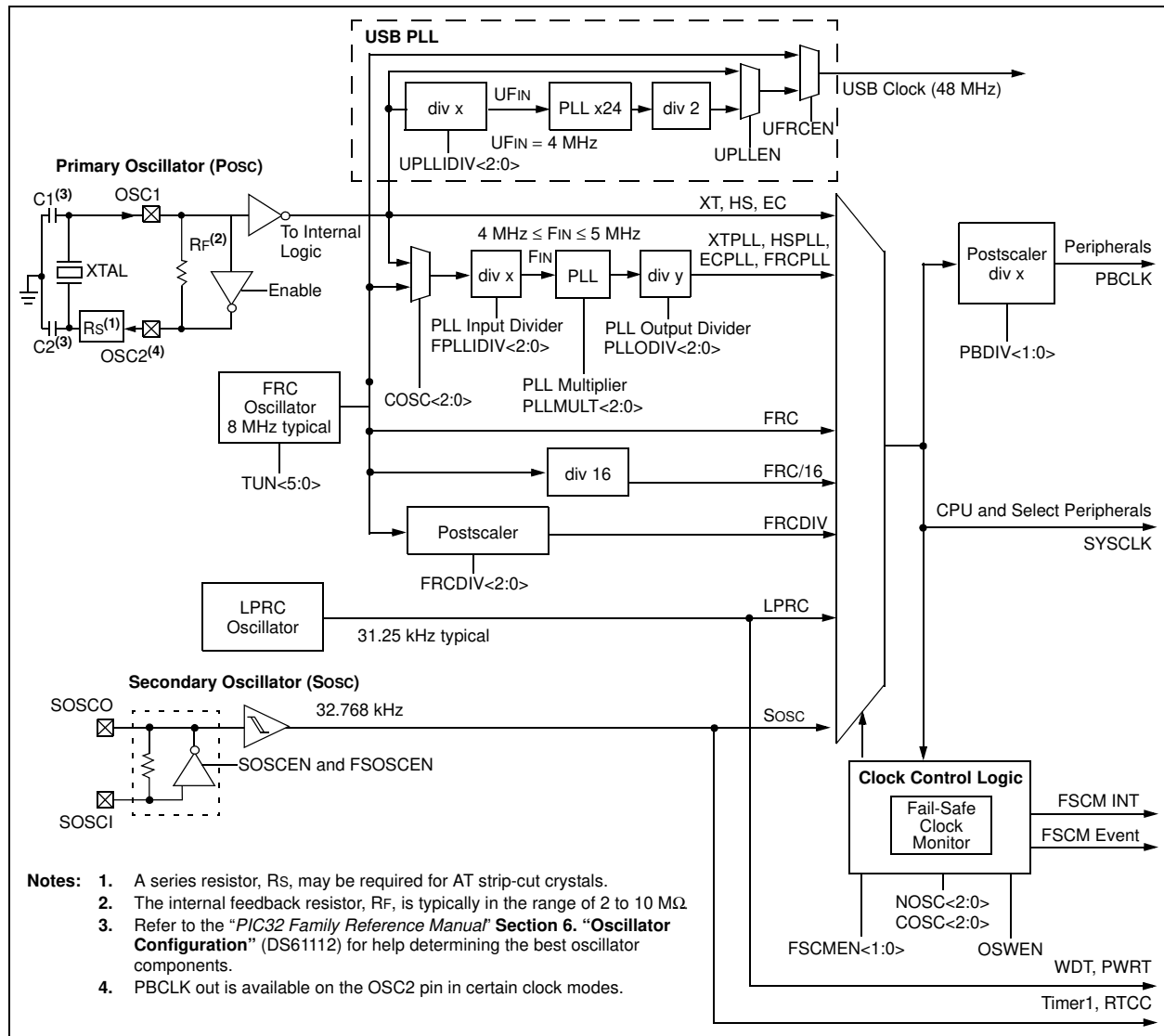

PIC32MX3XX/4XX

NOTES:

9.0 PREFETCH CACHE

Note 1: This data sheet summarizes the features of the PIC32MX3XX/4XX family of devices. It is not intended to be a comprehensive reference source. To complement the information in this data sheet, refer to **Section 4. “Prefetch Cache”** (DS61119) of the *“PIC32 Family Reference Manual”*, which is available from the Microchip web site (www.microchip.com/PIC32).

2: Some registers and associated bits described in this section may not be available on all devices. Refer to **Section 4.0 “Memory Organization”** in this data sheet for device-specific register and bit information.

Prefetch cache increases performance for applications executing out of the cacheable program Flash memory regions by implementing instruction caching, constant data caching and instruction prefetching.

9.1 Features

- 16 Fully Associative Lockable Cache Lines
- 16-byte Cache Lines
- Up to four Cache Lines Allocated to Data
- Two Cache Lines with Address Mask to hold repeated instructions
- Pseudo LRU replacement policy
- All Cache Lines are software writable
- 16-byte parallel memory fetch
- Predictive Instruction Prefetch

FIGURE 9-1: PREFETCH MODULE BLOCK DIAGRAM

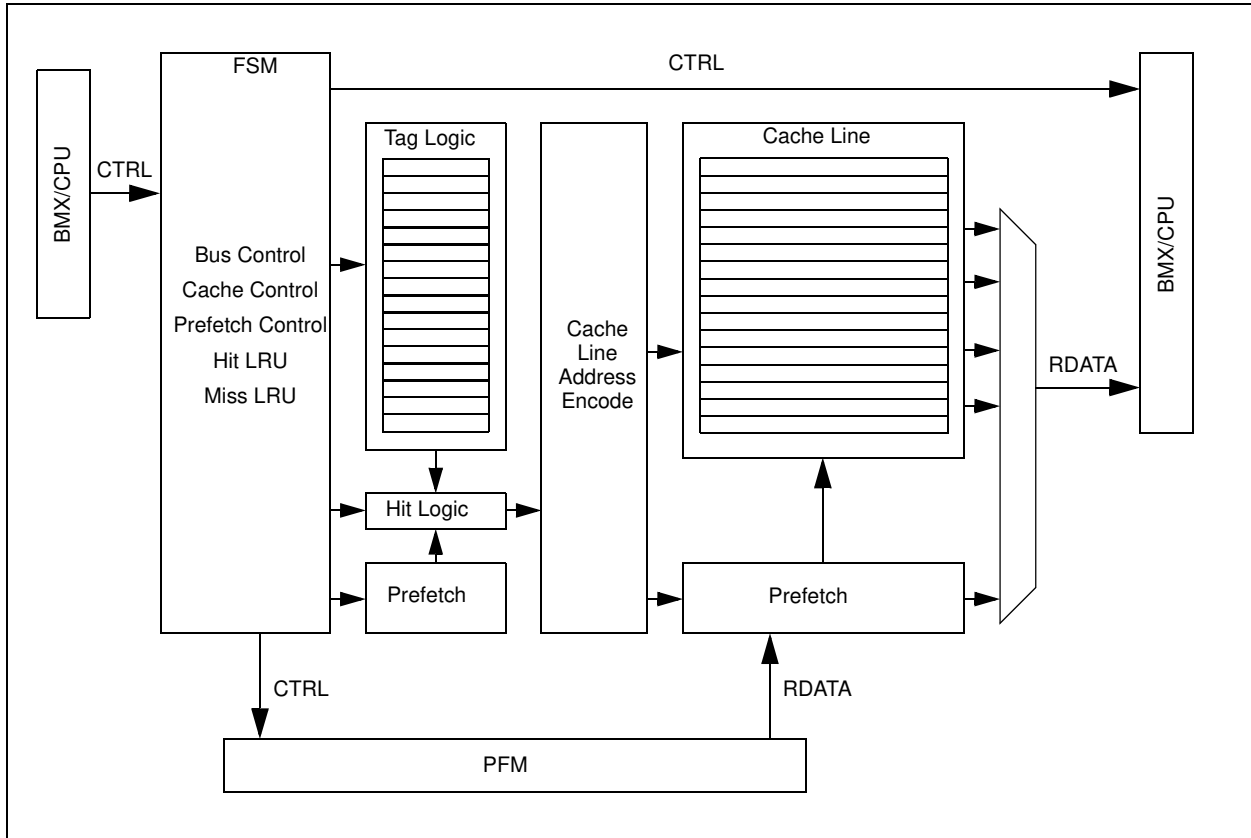

PIC32MX3XX/4XX

NOTES:

10.0 DIRECT MEMORY ACCESS (DMA) CONTROLLER

Note 1: This data sheet summarizes the features of the PIC32MX3XX/4XX family of devices. It is not intended to be a comprehensive reference source. To complement the information in this data sheet, refer to **Section 31. "Direct Memory Access (DMA) Controller"** (DS61117) of the "PIC32 Family Reference Manual", which is available from the Microchip web site (www.microchip.com/PIC32).

2: Some registers and associated bits described in this section may not be available on all devices. Refer to **Section 4.0 "Memory Organization"** in this data sheet for device-specific register and bit information.

The PIC32MX Direct Memory Access (DMA) controller is a bus master module useful for data transfers between different devices without CPU intervention. The source and destination of a DMA transfer can be any of the memory mapped modules existent in the PIC32MX (such as Peripheral Bus (PBUS) devices: SPI, UART, PMP, and so on) or memory itself.

Following are some of the key features of the DMA controller module:

- Four Identical Channels, each featuring:
 - Auto-Increment Source and Destination Address Registers
 - Source and Destination Pointers
 - Memory to Memory and Memory to Peripheral Transfers

- Automatic Word-Size Detection:
 - Transfer Granularity, down to byte level
 - Bytes need not be word-aligned at source and destination
- Fixed Priority Channel Arbitration
- Flexible DMA Channel Operating Modes:
 - Manual (software) or automatic (interrupt) DMA requests
 - One-Shot or Auto-Repeat Block Transfer modes
 - Channel-to-channel chaining
- Flexible DMA Requests:
 - A DMA request can be selected from any of the peripheral interrupt sources
 - Each channel can select any (appropriate) observable interrupt as its DMA request source
 - A DMA transfer abort can be selected from any of the peripheral interrupt sources
 - Pattern (data) match transfer termination
- Multiple DMA Channel Status Interrupts:
 - DMA channel block transfer complete
 - Source empty or half empty
 - Destination full or half-full
 - DMA transfer aborted due to an external event
 - Invalid DMA address generated
- DMA Debug Support Features:
 - Most recent address accessed by a DMA channel
 - Most recent DMA channel to transfer data
- CRC Generation Module:
 - CRC module can be assigned to any of the available channels
 - CRC module is highly configurable

FIGURE 10-1: DMA BLOCK DIAGRAM

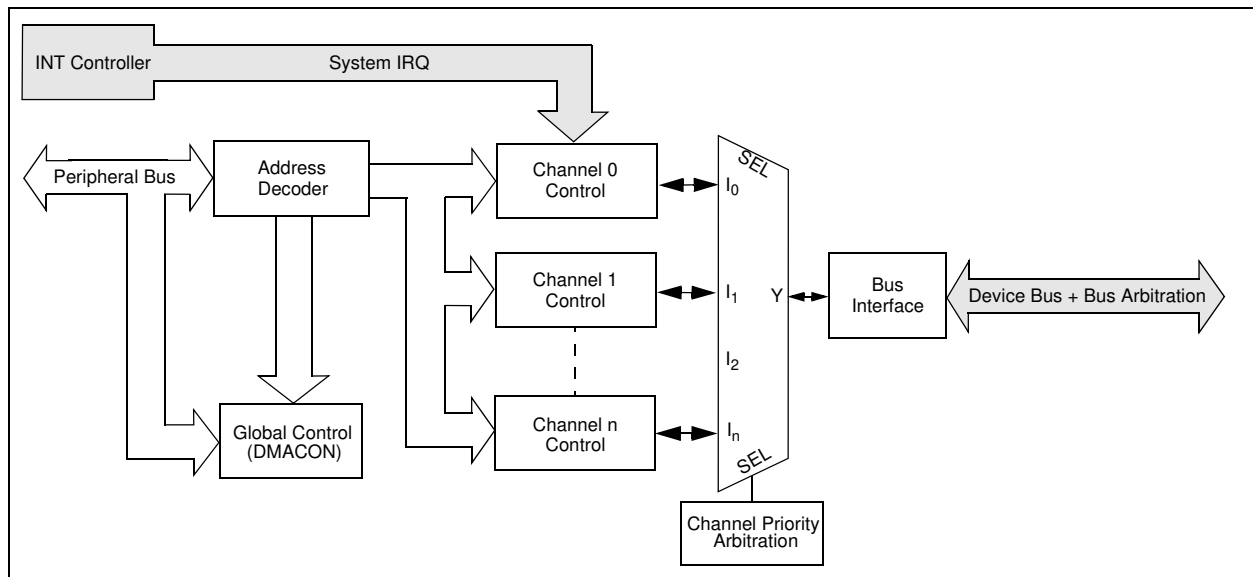

PIC32MX3XX/4XX

NOTES:

11.0 USB ON-THE-GO (OTG)

Note 1: This data sheet summarizes the features of the PIC32MX3XX/4XX family of devices. It is not intended to be a comprehensive reference source. To complement the information in this data sheet, refer to **Section 27. “USB On-The-Go (OTG)”** (DS61126) of the *“PIC32 Family Reference Manual”*, which is available from the Microchip web site (www.microchip.com/PIC32).

2: Some registers and associated bits described in this section may not be available on all devices. Refer to **Section 4.0 “Memory Organization”** in this data sheet for device-specific register and bit information.

The Universal Serial Bus (USB) module contains analog and digital components to provide a USB 2.0 full-speed and low-speed embedded host, full-speed device, or OTG implementation with a minimum of external components. This module in Host mode is intended for use as an embedded host and therefore does not implement a UHCI or OHCI controller.

The USB module consists of the clock generator, the USB voltage comparators, the transceiver, the Serial Interface Engine (SIE), a dedicated USB DMA controller, pull-up and pull-down resistors, and the register interface. A block diagram of the PIC32MX USB OTG module is presented in [Figure 11-1](#).

The clock generator provides the 48 MHz clock required for USB full-speed and low-speed communication. The voltage comparators monitor the voltage on the VBUS pin to determine the state of the bus. The transceiver provides the analog translation between the USB bus and the digital logic. The SIE is a state machine that transfers data to and from the endpoint buffers, and generates the hardware protocol for data transfers. The USB DMA controller transfers data between the data buffers in RAM and the SIE. The integrated pull-up and pull-down resistors eliminate the need for external signaling components. The register interface allows the CPU to configure and communicate with the module.

The PIC32MX USB module includes the following features:

- USB Full-Speed Support for Host and Device
- Low-Speed Host Support
- USB OTG Support
- Integrated Signaling Resistors
- Integrated Analog Comparators for VBUS Monitoring
- Integrated USB Transceiver
- Transaction Handshaking Performed by Hardware
- Endpoint Buffering Anywhere in System RAM
- Integrated DMA to Access System RAM and Flash

Note: The implementation and use of the USB specifications, as well as other third-party specifications or technologies, may require licensing; including, but not limited to, USB Implementers Forum, Inc. (also referred to as USB-IF). The user is fully responsible for investigating and satisfying any applicable licensing obligations.

PIC32MX3XX/4XX

FIGURE 11-1: PIC32MX3XX/4XX FAMILY USB INTERFACE DIAGRAM

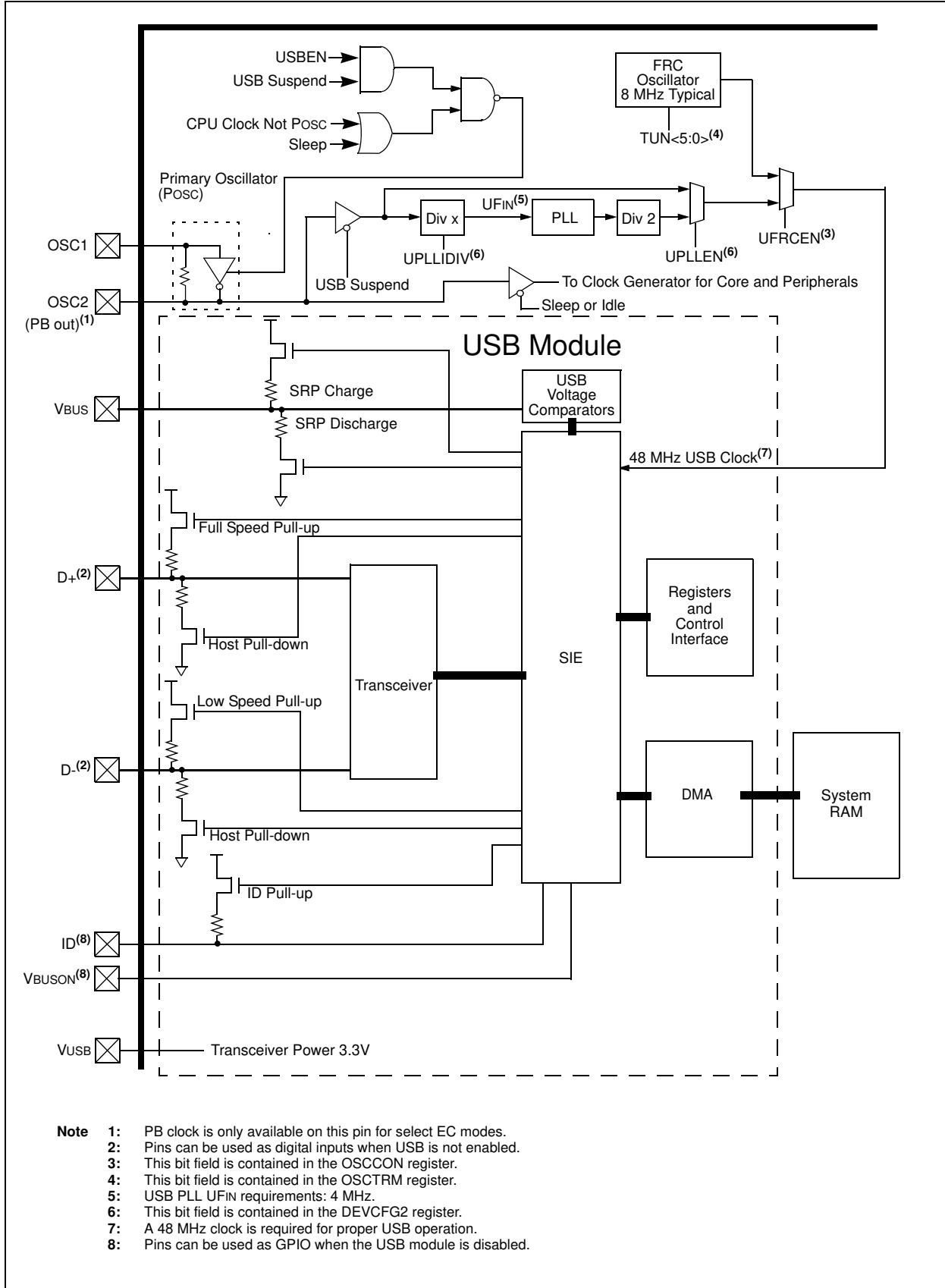

12.0 I/O PORTS

Note 1: This data sheet summarizes the features of the PIC32MX3XX/4XX family of devices. It is not intended to be a comprehensive reference source. To complement the information in this data sheet, refer to **Section 12. “I/O Ports”** (DS61120) of the “PIC32 Family Reference Manual”, which is available from the Microchip web site (www.microchip.com/PIC32).

2: Some registers and associated bits described in this section may not be available on all devices. Refer to **Section 4.0 “Memory Organization”** in this data sheet for device-specific register and bit information.

General purpose I/O pins are the simplest of peripherals. They allow the PIC® MCU to monitor and control other devices. To add flexibility and functionality, some pins are multiplexed with alternate function(s). These functions depend on which peripheral features are on the device. In general, when a peripheral is functioning, that pin may not be used as a general purpose I/O pin.

Following are some of the key features of this module:

- Individual Output Pin Open-drain Enable/Disable
- Individual Input Pin Weak Pull-up Enable/Disable
- Monitor Selective Inputs and Generate Interrupt when Change in Pin State is Detected
- Operation during CPU Sleep and Idle modes
- Fast Bit Manipulation using CLR, SET and INV Registers

Figure 12-1 illustrates a block diagram of a typical multiplexed I/O port.

FIGURE 12-1: BLOCK DIAGRAM OF A TYPICAL MULTIPLEXED PORT STRUCTURE

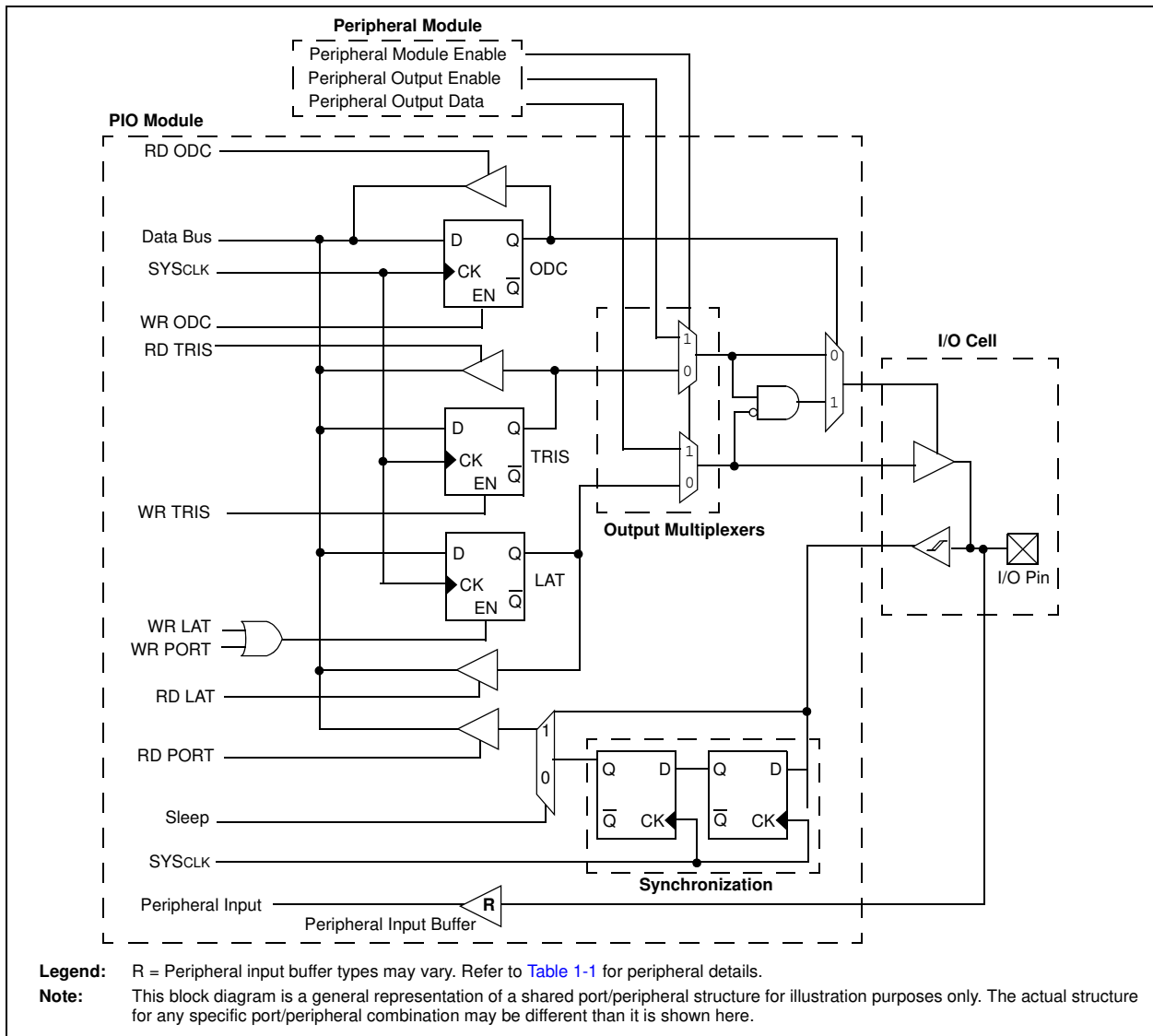

PIC32MX3XX/4XX

12.1 Parallel I/O (PIO) Ports

All port pins have three registers (TRIS, LAT and PORT) that are directly associated with their operation.

TRIS is a data direction or tri-state control register that determines whether a digital pin is an input or an output. Setting a TRISx register bit = 1 configures the corresponding I/O pin as an input; setting a TRISx register bit = 0 configures the corresponding I/O pin as an output. All port I/O pins are defined as inputs after a device Reset. Certain I/O pins are shared with analog peripherals and default to analog inputs after a device Reset.

PORT is a register used to read the current state of the signal applied to the port I/O pins. Writing to a PORTx register performs a write to the port's latch, LATx register, latching the data to the port's I/O pins.

LAT is a register used to write data to the port I/O pins. The LATx latch register holds the data written to either the LATx or PORTx registers. Reading the LATx latch register reads the last value written to the corresponding port or latch register.

Not all port I/O pins are implemented on some devices, therefore, the corresponding PORTx, LATx and TRISx register bits will read as zeros.

12.1.1 CLR, SET AND INV REGISTERS

Every I/O module register has a corresponding CLR (clear), SET (set) and INV (invert) register designed to provide fast atomic bit manipulations. As the name of the register implies, a value written to a SET, CLR or INV register effectively performs the implied operation, but only on the corresponding base register and only bits specified as '1' are modified. Bits specified as '0' are not modified.

Reading SET, CLR and INV registers returns undefined values. To see the affects of a write operation to a SET, CLR or INV register, the base register must be read.

Note: Using a PORTxINV register to toggle a bit is recommended because the operation is performed in hardware atomically, using fewer instructions as compared to the traditional read-modify-write method shown below:

```
PORTC ^= 0x0001;
```

12.1.2 DIGITAL INPUTS

Pins are configured as digital inputs by setting the corresponding TRIS register bits = 1. When configured as inputs, they are either TTL buffers or Schmitt Triggers. Several digital pins share functionality with analog inputs and default to the analog inputs at POR. Setting the corresponding bit in the AD1PCFG register = 1 enables the pin as a digital pin.

The maximum input voltage allowed on the input pins is the same as the maximum V_{IH} specification. Refer to [Section 29.0 “Electrical Characteristics”](#) for V_{IH} specification details.

Note: Analog levels on any pin that is defined as a digital input (including the ANx pins) may cause the input buffer to consume current that exceeds the device specifications.

12.1.3 ANALOG INPUTS

Certain pins can be configured as analog inputs used by the ADC and Comparator modules. Setting the corresponding bits in the AD1PCFG register = 0 enables the pin as an analog input pin and must have the corresponding TRIS bit set = 1 (input). If the TRIS bit is cleared = 0 (output), the digital output level (V_{OH} or V_{OL}) will be converted. Any time a port I/O pin is configured as analog, its digital input is disabled and the corresponding PORTx register bit will read '0'. The AD1PCFG Register has a default value of 0x0000; therefore, all pins that share ANx functions are analog (not digital) by default.

12.1.4 DIGITAL OUTPUTS

Pins are configured as digital outputs by setting the corresponding TRIS register bits = 0. When configured as digital outputs, these pins are CMOS drivers or can be configured as open drain outputs by setting the corresponding bits in the ODCx Open-Drain Configuration register.

The open-drain feature allows the generation of outputs higher than V_{DD} (e.g., 5V) on any desired 5V tolerant pins by using external pull-up resistors. The maximum open-drain voltage allowed is the same as the maximum V_{IH} specification.

See the [“Pin Diagrams”](#) section for the available pins and their functionality.

12.1.5 ANALOG OUTPUTS

Certain pins can be configured as analog outputs, such as the CVREF output voltage used by the comparator module. Configuring the Comparator Reference module to provide this output will present the analog output voltage on the pin, independent of the TRIS register setting for the corresponding pin.

12.1.6 INPUT CHANGE NOTIFICATION

The input change notification function of the I/O ports (CNx) allows devices to generate interrupt requests in response to change of state on selected pin.

Each CNx pin also has a weak pull-up, which acts as a current source connected to the pin. The pull-ups are enabled by setting corresponding bit in CNPUE register.

13.0 TIMER1

Note 1: This data sheet summarizes the features of the PIC32MX3XX/4XX family of devices. It is not intended to be a comprehensive reference source. To complement the information in this data sheet, refer to **Section 14. “Timers”** (DS61105) of the “PIC32 Family Reference Manual”, which is available from the Microchip web site (www.microchip.com/PIC32).

2: Some registers and associated bits described in this section may not be available on all devices. Refer to **Section 4.0 “Memory Organization”** in this data sheet for device-specific register and bit information.

This family of PIC32MX devices features one synchronous/asynchronous 16-bit timer that can operate as a free-running interval timer for various timing applications and counting external events. This timer can also be used with the Secondary Oscillator (SOSC) for real-time clock applications. The following modes are supported:

- Synchronous Internal Timer
- Synchronous Internal Gated Timer
- Synchronous External Timer
- Asynchronous External Timer

13.1 Additional Supported Features

- Selectable clock prescaler
- Timer operation during CPU Idle and Sleep mode
- Fast bit manipulation using CLR, SET and INV registers
- Asynchronous mode can be used with the Sosc to function as a Real-Time Clock (RTC)

FIGURE 13-1: TIMER1 BLOCK DIAGRAM⁽¹⁾

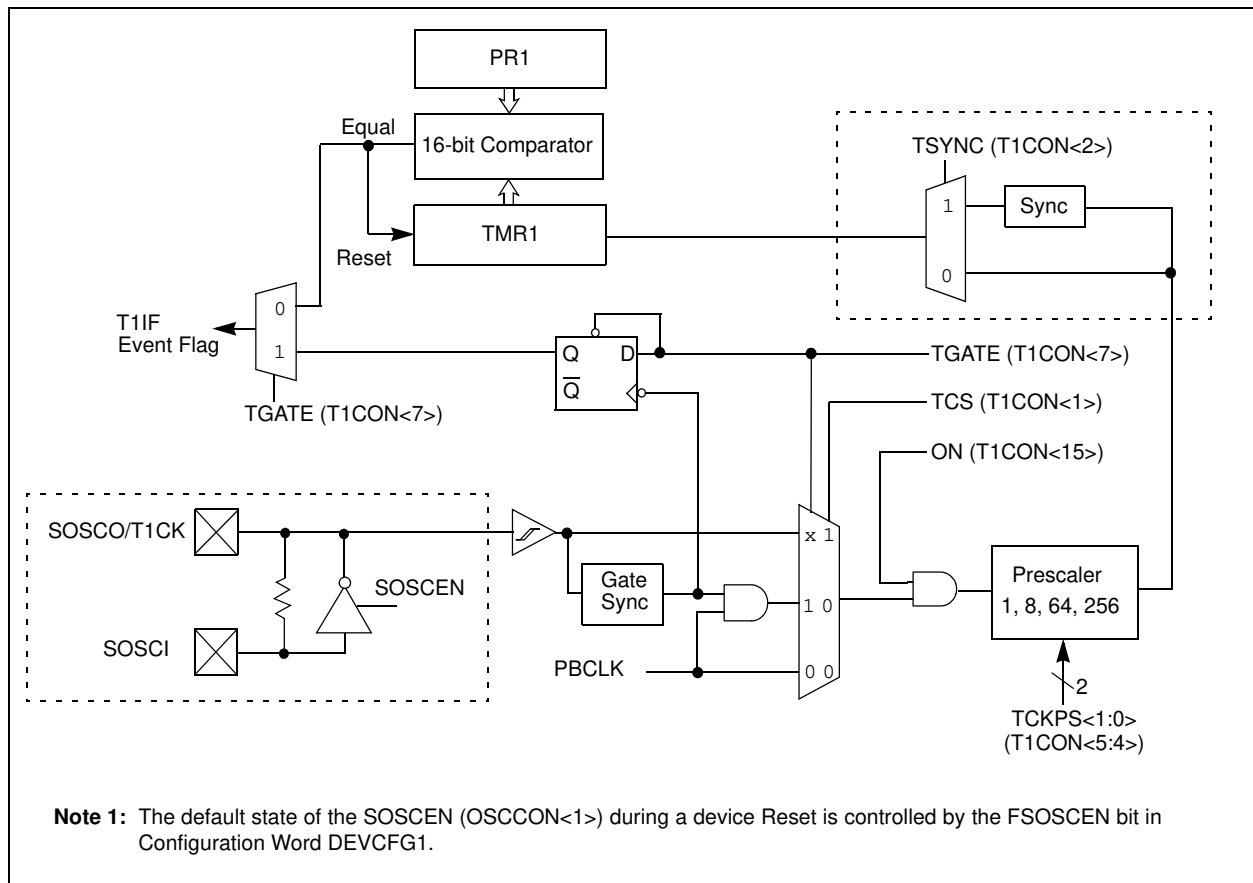

PIC32MX3XX/4XX

NOTES:

14.0 TIMER2/3 AND TIMER4/5

Note 1: This data sheet summarizes the features of the PIC32MX3XX/4XX family of devices. It is not intended to be a comprehensive reference source. To complement the information in this data sheet, refer to **Section 14. “Timers”** (DS61105) of the *“PIC32 Family Reference Manual”*, which is available from the Microchip web site (www.microchip.com/PIC32).

2: Some registers and associated bits described in this section may not be available on all devices. Refer to **Section 4.0 “Memory Organization”** in this data sheet for device-specific register and bit information.

This family of PIC32MX devices features four synchronous 16-bit timers (default) that can operate as a free-running interval timer for various timing applications and counting external events. The following modes are supported:

- Synchronous Internal 16-bit Timer
- Synchronous Internal 16-bit Gated Timer
- Synchronous External 16-bit Timer

Two 32-bit synchronous timers are available by combining Timer2 with Timer3 and Timer4 with Timer5. The 32-bit timers can operate in three modes:

- Synchronous Internal 32-bit Timer
- Synchronous Internal 32-bit Gated Timer
- Synchronous External 32-bit Timer

Note: Throughout this chapter, references to registers TxCON, TMRx and PRx use ‘x’ to represent Timer2 through 5 in 16-bit modes. In 32-bit modes, ‘x’ represents Timer2 or 4; ‘y’ represents Timer3 or 5.

14.1 Additional Supported Features

- Selectable clock prescaler
- Timers operational during CPU Idle
- Time base for input capture and output compare modules (Timer2 and Timer3 only)
- ADC event trigger (Timer3 only)
- Fast bit manipulation using CLR, SET and INV registers

FIGURE 14-1: TIMER2, 3, 4, 5 BLOCK DIAGRAM (16-BIT)

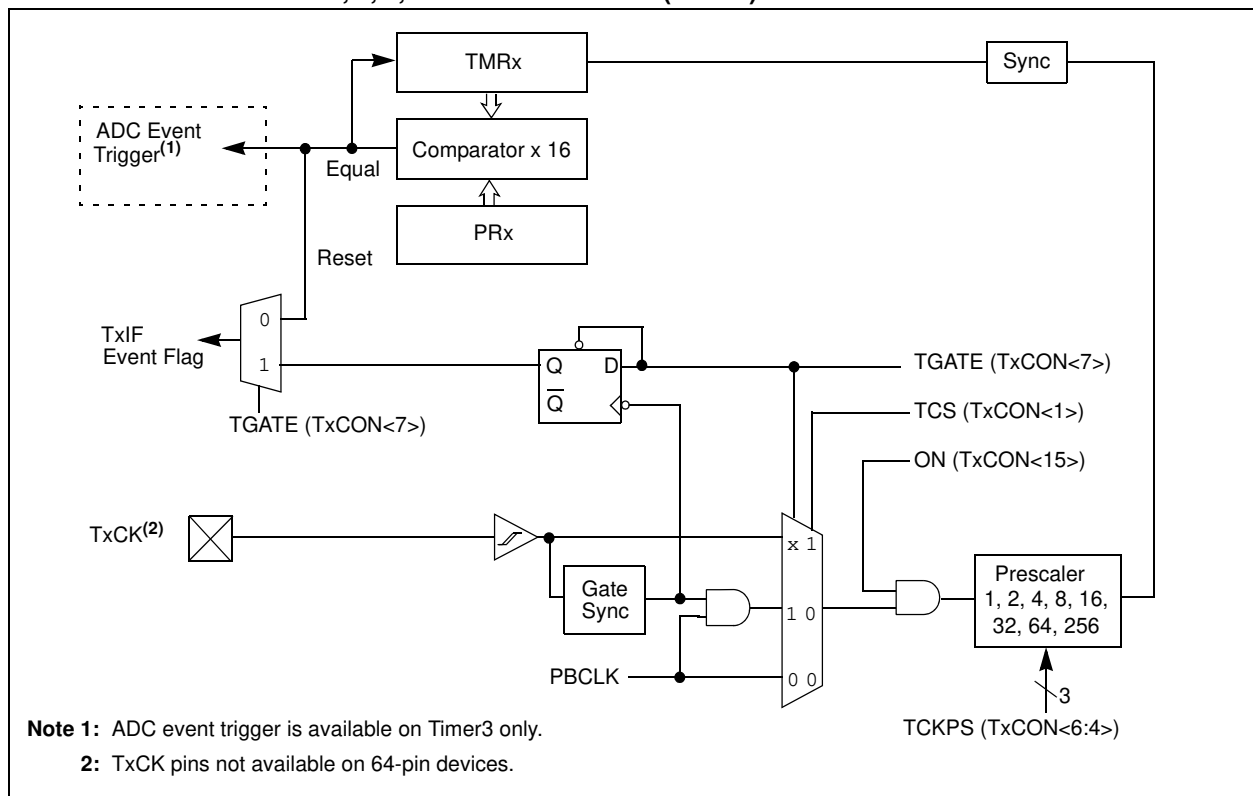

PIC32MX3XX/4XX

FIGURE 14-2: TIMER2/3, 4/5 BLOCK DIAGRAM (32-BIT)

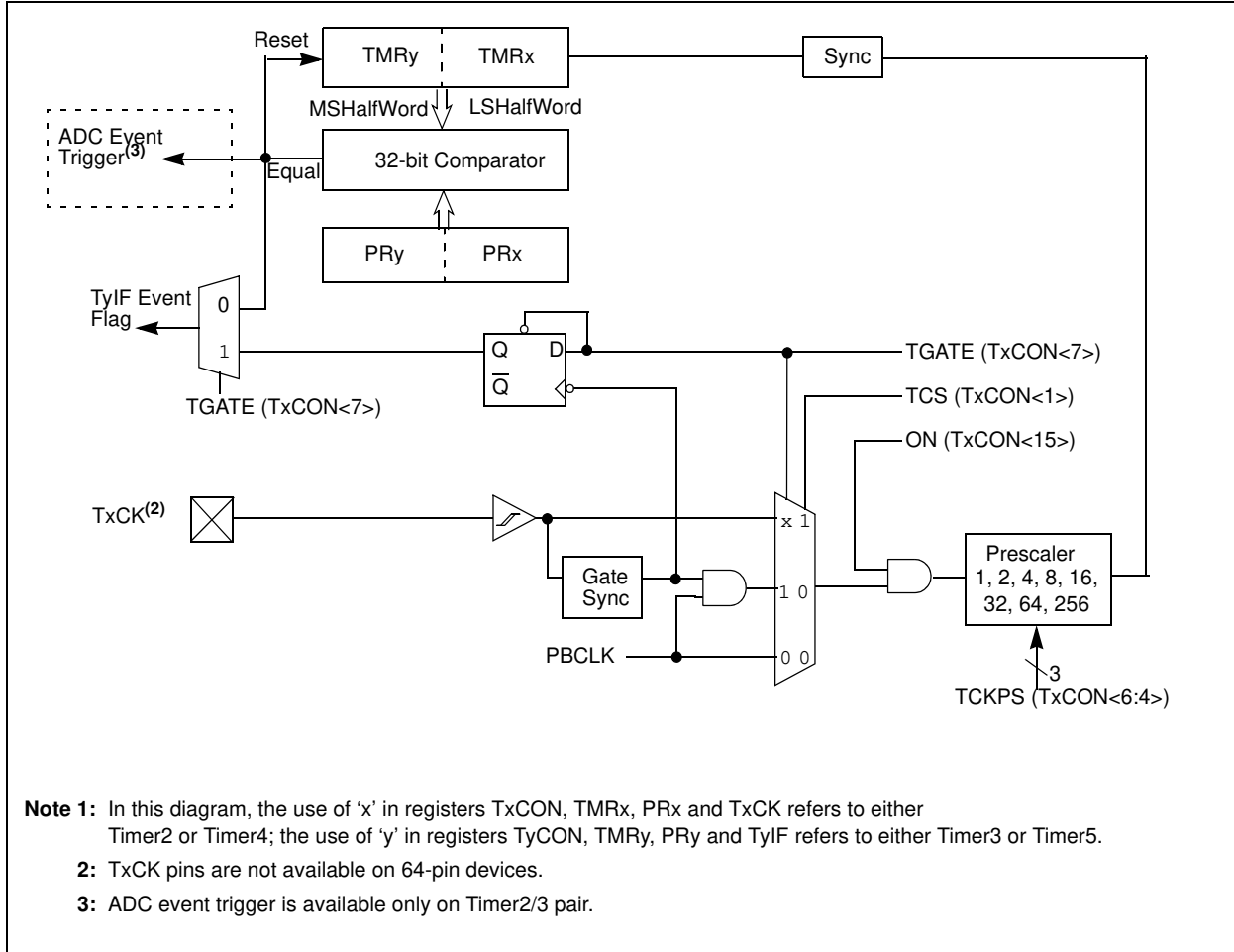

15.0 INPUT CAPTURE

Note 1: This data sheet summarizes the features of the PIC32MX3XX/4XX family of devices. It is not intended to be a comprehensive reference source. To complement the information in this data sheet, refer to **Section 15. “Input Capture”** (DS61122) of the “PIC32 Family Reference Manual”, which is available from the Microchip web site (www.microchip.com/PIC32).

2: Some registers and associated bits described in this section may not be available on all devices. Refer to **Section 4.0 “Memory Organization”** in this data sheet for device-specific register and bit information.

The Input Capture module is useful in applications requiring frequency (period) and pulse measurement. The PIC32MX3XX/4XX devices support up to five input capture channels.

The Input Capture module captures the 16-bit or 32-bit value of the selected Time Base registers when an event occurs at the ICx pin. The events that cause a capture event are listed below in three categories:

1. Simple Capture Event modes
 - Capture timer value on every falling edge of input at ICx pin
 - Capture timer value on every rising edge of input at ICx pin

2. Capture timer value on every edge (rising and falling)
3. Capture timer value on every edge (rising and falling), specified edge first.
4. Prescaler Capture Event modes
 - Capture timer value on every 4th rising edge of input at ICx pin
 - Capture timer value on every 16th rising edge of input at ICx pin

Each input capture channel can select between one of two 16-bit timers (Timer2 or Timer3) for the time base, or two 16-bit timers (Timer2 and Timer3) together to form a 32-bit timer. The selected timer can use either an internal or external clock.

Other operational features include:

- Device wake-up from capture pin during CPU Sleep and Idle modes
- Interrupt on input capture event
- 4-word FIFO buffer for capture values
 - Interrupt optionally generated after 1, 2, 3 or 4 buffer locations are filled
- Input capture can also be used to provide additional sources of external interrupts

FIGURE 15-1: INPUT CAPTURE BLOCK DIAGRAM

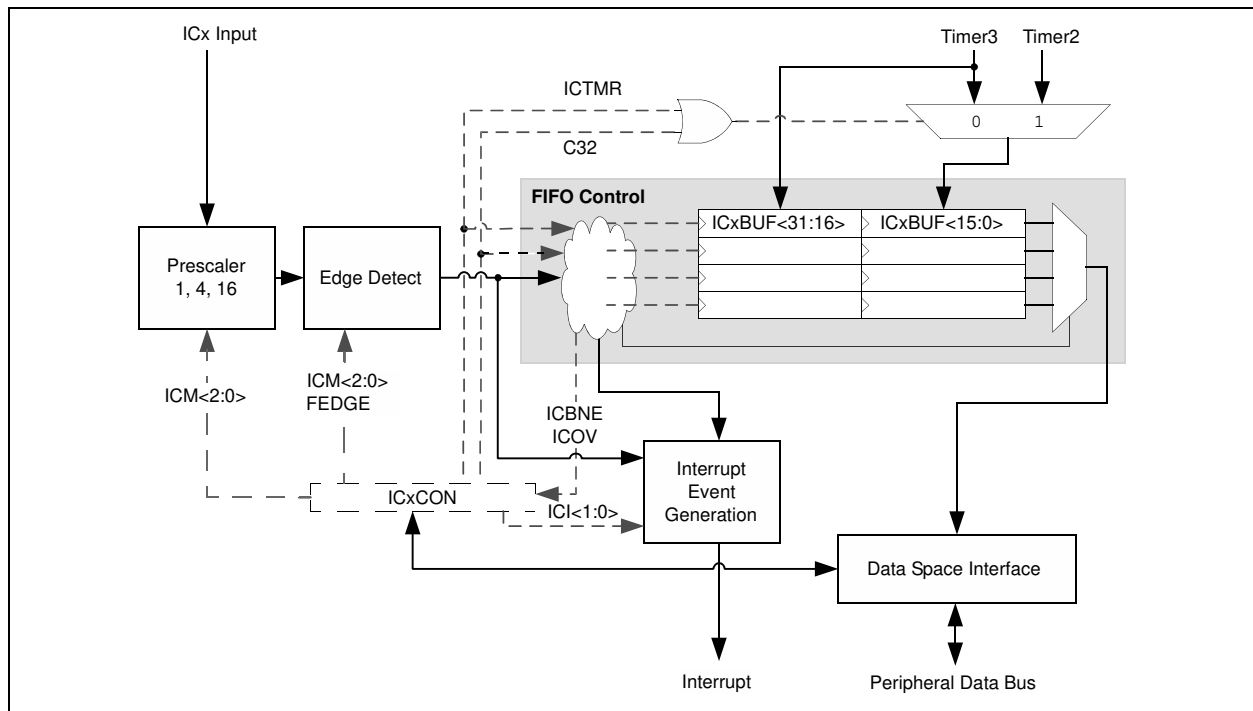

PIC32MX3XX/4XX

NOTES:

16.0 OUTPUT COMPARE

Note 1: This data sheet summarizes the features of the PIC32MX3XX/4XX family of devices. It is not intended to be a comprehensive reference source. To complement the information in this data sheet, refer to **Section 16. “Output Compare”** (DS61111) of the “PIC32 Family Reference Manual”, which is available from the Microchip web site (www.microchip.com/PIC32).

2: Some registers and associated bits described in this section may not be available on all devices. Refer to **Section 4.0 “Memory Organization”** in this data sheet for device-specific register and bit information.

The Output Compare module (OCMP) is used to generate a single pulse or a train of pulses in response to selected time base events. For all modes of operation, the OCMP module compares the values stored in the OCxR and/or the OCxRS registers to the value in the selected timer. When a match occurs, the OCMP module generates an event based on the selected mode of operation.

The following are some of the key features:

- Multiple output compare modules in a device
- Programmable interrupt generation on compare event
- Single and Dual Compare modes
- Single and continuous output pulse generation
- Pulse-Width Modulation (PWM) mode
- Hardware-based PWM Fault detection and automatic output disable
- Programmable selection of 16-bit or 32-bit time bases.
- Can operate from either of two available 16-bit time bases or a single 32-bit time base

FIGURE 16-1: OUTPUT COMPARE MODULE BLOCK DIAGRAM

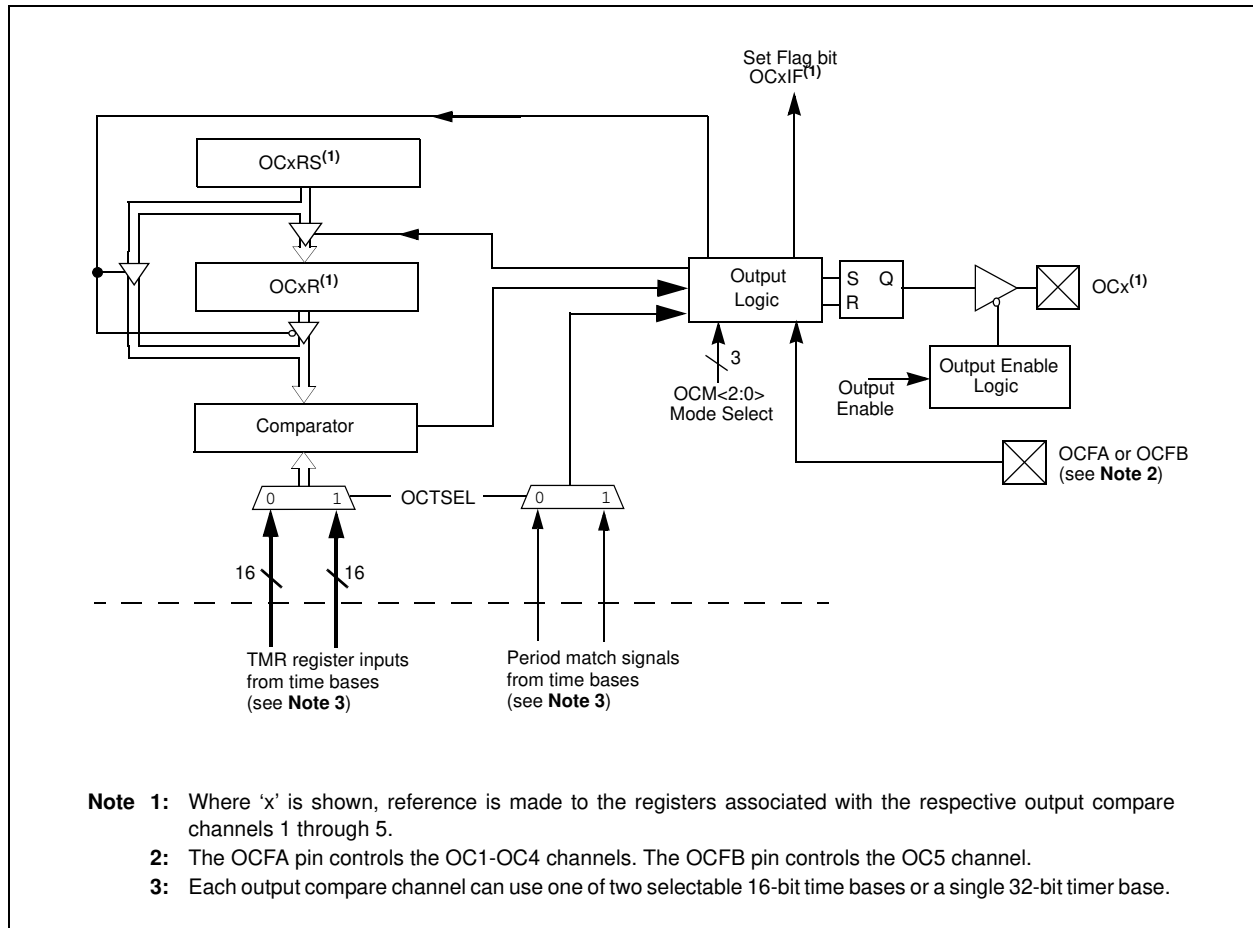

PIC32MX3XX/4XX

NOTES:

17.0 SERIAL PERIPHERAL INTERFACE (SPI)

Note 1: This data sheet summarizes the features of the PIC32MX3XX/4XX family of devices. It is not intended to be a comprehensive reference source. To complement the information in this data sheet, refer to **Section 23. “Serial Peripheral Interface (SPI)”** (DS61106) of the *“PIC32 Family Reference Manual”*, which is available from the Microchip web site (www.microchip.com/PIC32).

2: Some registers and associated bits described in this section may not be available on all devices. Refer to **Section 4.0 “Memory Organization”** in this data sheet for device-specific register and bit information.

The SPI module is a synchronous serial interface useful for communicating with external peripherals and other microcontroller devices. These peripheral devices may be Serial EEPROMs, shift registers, display drivers, Analog-to-Digital Converters, etc. The PIC32MX SPI module is compatible with Motorola® SPI and SIOP interfaces.

Following are some of the key features of this module:

- Master and Slave Modes Support
- Four Different Clock Formats
- Framed SPI Protocol Support
- User Configurable 8-bit, 16-bit and 32-bit Data Width
- Separate SPI Data Registers for Receive and Transmit
- Programmable Interrupt Event on every 8-bit, 16-bit and 32-bit Data Transfer
- Operation during CPU Sleep and Idle Mode
- Fast Bit Manipulation using CLR, SET and INV Registers

FIGURE 17-1: SPI MODULE BLOCK DIAGRAM

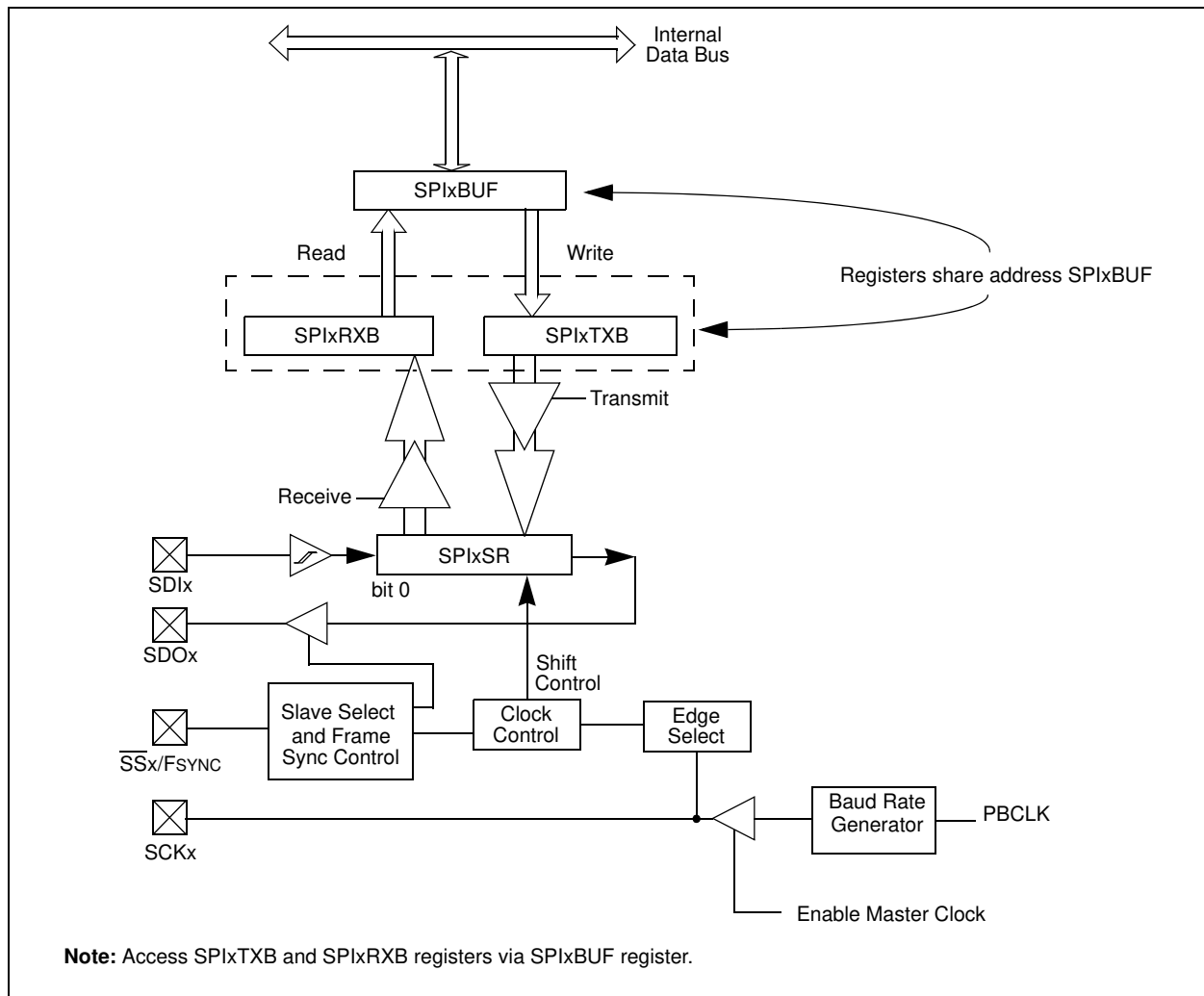

PIC32MX3XX/4XX

NOTES:

18.0 INTER-INTEGRATED CIRCUIT™ (I²C™)

Note 1: This data sheet summarizes the features of the PIC32MX3XX/4XX family of devices. It is not intended to be a comprehensive reference source. To complement the information in this data sheet, refer to **Section 24. “Inter-Integrated Circuit (I²C™)”** (DS61116) of the “*PIC32 Family Reference Manual*”, which is available from the Microchip web site (www.microchip.com/PIC32).

2: Some registers and associated bits described in this section may not be available on all devices. Refer to **Section 4.0 “Memory Organization”** in this data sheet for device-specific register and bit information.

The I²C module provides complete hardware support for both Slave and Multi-Master modes of the I²C serial communication standard. [Figure 18-1](#) illustrates the I²C module block diagram.

The PIC32MX3XX/4XX devices have up to two I²C interface modules, denoted as I2C1 and I2C2. Each I²C module has a 2-pin interface: the SCLx pin is clock and the SDAx pin is data.

Each I²C module, ‘I2Cx’ (x = 1 or 2), offers the following key features:

- I²C Interface Supporting both Master and Slave Operation.
- I²C Slave Mode Supports 7 and 10-bit Address.
- I²C Master Mode Supports 7 and 10-bit Address.
- I²C Port allows Bidirectional Transfers between Master and Slaves.
- Serial Clock Synchronization for I²C Port can be used as a Handshake Mechanism to Suspend and Resume Serial Transfer (SCLREL control).
- I²C Supports Multi-master Operation; Detects Bus Collision and Arbitrates Accordingly.
- Provides Support for Address Bit Masking.

PIC32MX3XX/4XX

FIGURE 18-1: I²C™ BLOCK DIAGRAM (x = 1 OR 2)

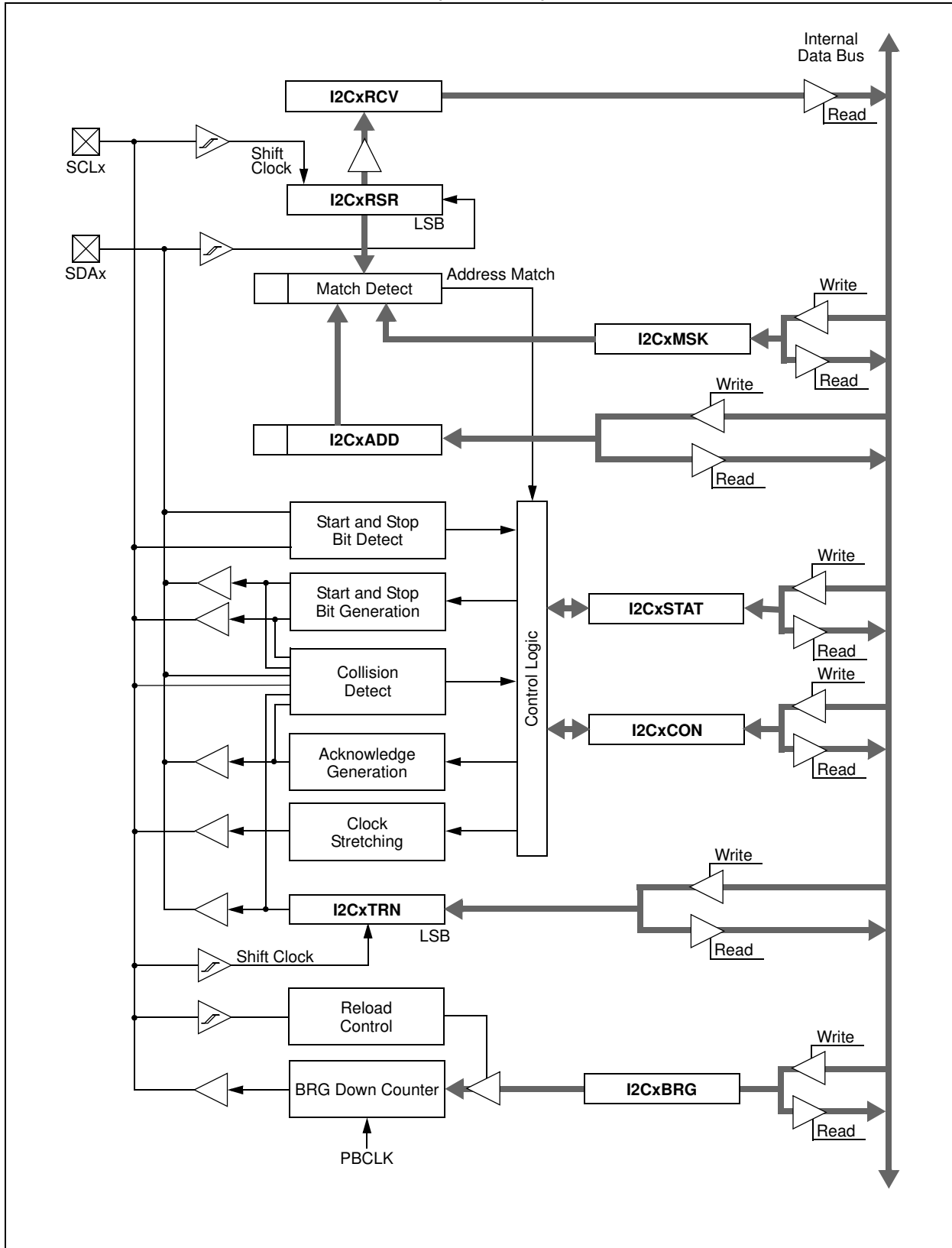

19.0 UNIVERSAL ASYNCHRONOUS RECEIVER TRANSMITTER (UART)

Note 1: This data sheet summarizes the features of the PIC32MX3XX/4XX family of devices. It is not intended to be a comprehensive reference source. To complement the information in this data sheet, refer to **Section 21. “Universal Asynchronous Receiver Transmitter (UART)”** (DS61107) of the “PIC32 Family Reference Manual”, which is available from the Microchip web site (www.microchip.com/PIC32).

Note 2: Some registers and associated bits described in this section may not be available on all devices. Refer to **Section 4.0 “Memory Organization”** in this data sheet for device-specific register and bit information.

The UART module is one of the serial I/O modules available in PIC32MX3XX/4XX family devices. The UART is a full-duplex, asynchronous communication channel that communicates with peripheral devices and personal computers through protocols such as RS-232, RS-485, LIN 1.2 and IrDA®. The module also supports the hardware flow control option, with UxCTS and UxRTS pins, and also includes an IrDA encoder and decoder.

The primary features of the UART module are:

- Full-duplex, 8-bit or 9-bit data transmission
- Even, odd or no parity options (for 8-bit data)
- One or two Stop bits
- Hardware auto-baud feature
- Hardware flow control option
- Fully integrated Baud Rate Generator (BRG) with 16-bit prescaler
- Baud rates ranging from 76 bps to 20 Mbps at 80 MHz
- 4-level-deep First-In-First-Out (FIFO) Transmit Data Buffer
- 4-level-deep FIFO Receive Data Buffer
- Parity, framing and buffer overrun error detection
- Support for interrupt only on address detect (9th bit = 1)
- Separate transmit and receive interrupts
- Loopback mode for diagnostic support
- LIN protocol support
- IrDA encoder and decoder with 16x baud clock output for external IrDA encoder/decoder support

Figure 19-1 illustrates a simplified block diagram of the UART.

FIGURE 19-1: UART SIMPLIFIED BLOCK DIAGRAM

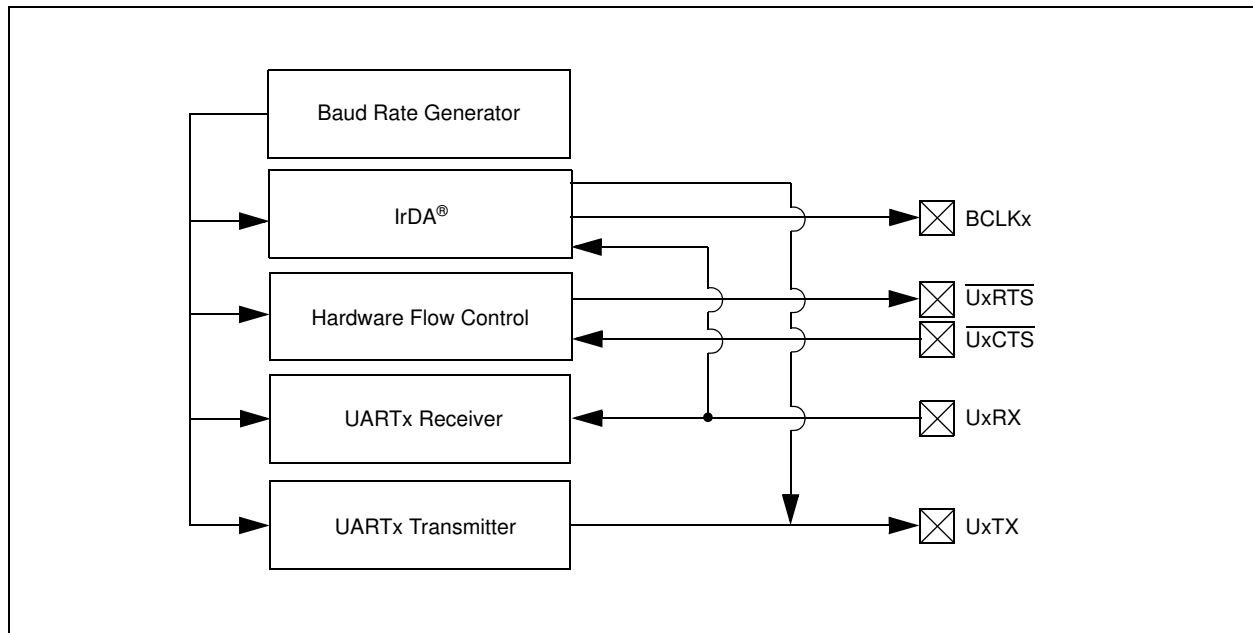

PIC32MX3XX/4XX

FIGURE 19-2: TRANSMISSION (8-BIT OR 9-BIT DATA)

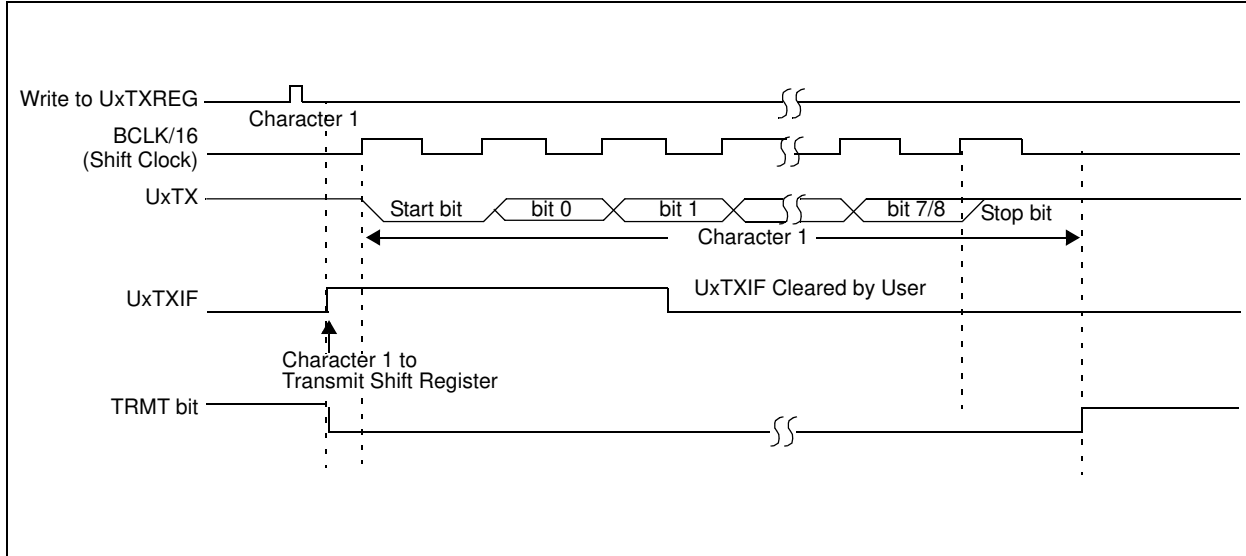

FIGURE 19-3: TWO CONSECUTIVE TRANSMISSIONS

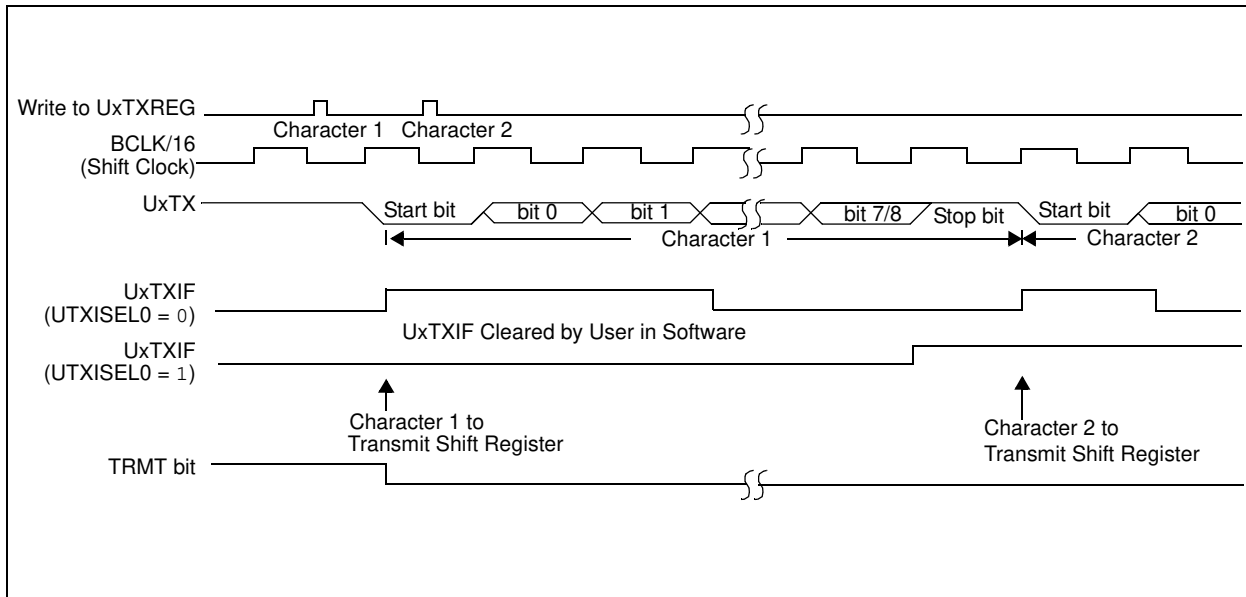

FIGURE 19-4: UART RECEPTION

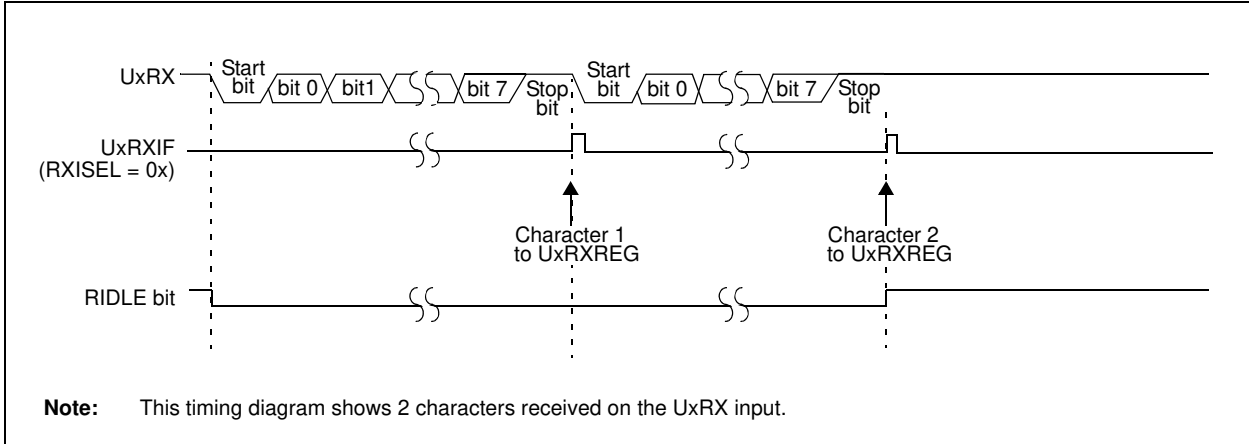
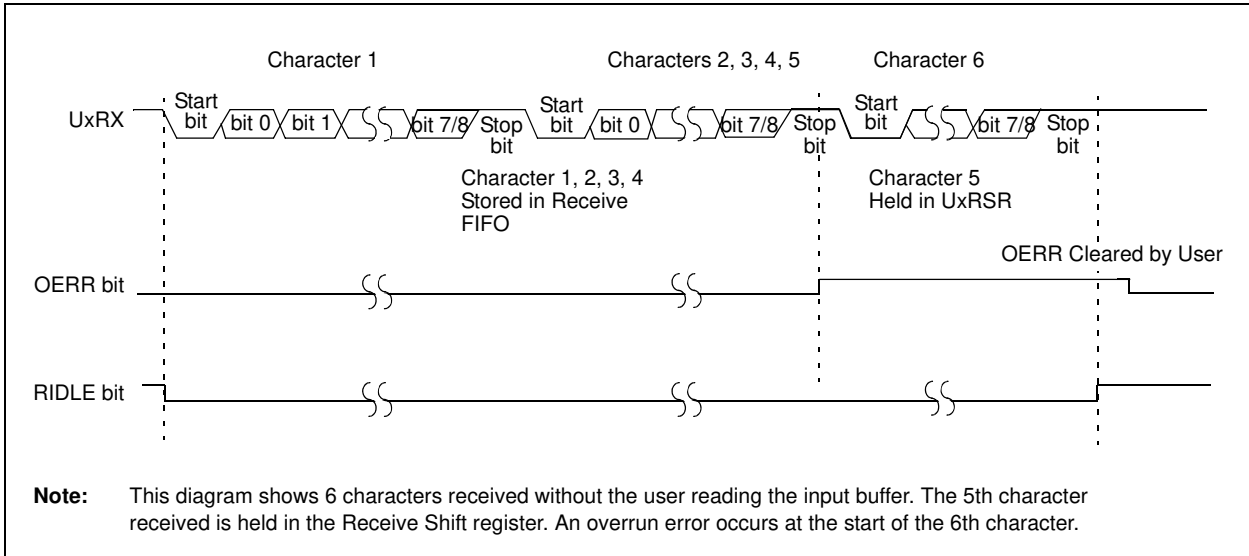

FIGURE 19-5: UART RECEPTION WITH RECEIVE OVERRUN



PIC32MX3XX/4XX

NOTES:

20.0 PARALLEL MASTER PORT (PMP)

Note 1: This data sheet summarizes the features of the PIC32MX3XX/4XX family of devices. It is not intended to be a comprehensive reference source. To complement the information in this data sheet, refer to **Section 13. “Parallel Master Port (PMP)”** (DS61128) of the “PIC32 Family Reference Manual”, which is available from the Microchip web site (www.microchip.com/PIC32).

2: Some registers and associated bits described in this section may not be available on all devices. Refer to **Section 4.0 “Memory Organization”** in this data sheet for device-specific register and bit information.

The PMP is a parallel 8-bit/16-bit input/output module specifically designed to communicate with a wide variety of parallel devices, such as communications peripherals, LCDs, external memory devices and microcontrollers. Because the interface to parallel peripherals varies significantly, the PMP module is highly configurable.

Key features of the PMP module include:

- 8-bit, 16-bit interface
- Up to 16 programmable address lines
- Up to two Chip Select lines
- Programmable strobe options
 - Individual read and write strobes, or
 - Read/write strobe with enable strobe
- Address auto-increment/auto-decrement
- Programmable address/data multiplexing
- Programmable polarity on control signals
- Parallel Slave Port support
 - Legacy addressable
 - Address support
 - 4-byte deep auto-incrementing buffer
- Programmable Wait states
- Operate during CPU Sleep and Idle modes
- Fast bit manipulation using CLR, SET and INV registers
- Freeze option for in-circuit debugging

Note: On 64-pin devices, data pins PMD<15:8> are not available.

FIGURE 20-1: PMP MODULE PINOUT AND CONNECTIONS TO EXTERNAL DEVICES

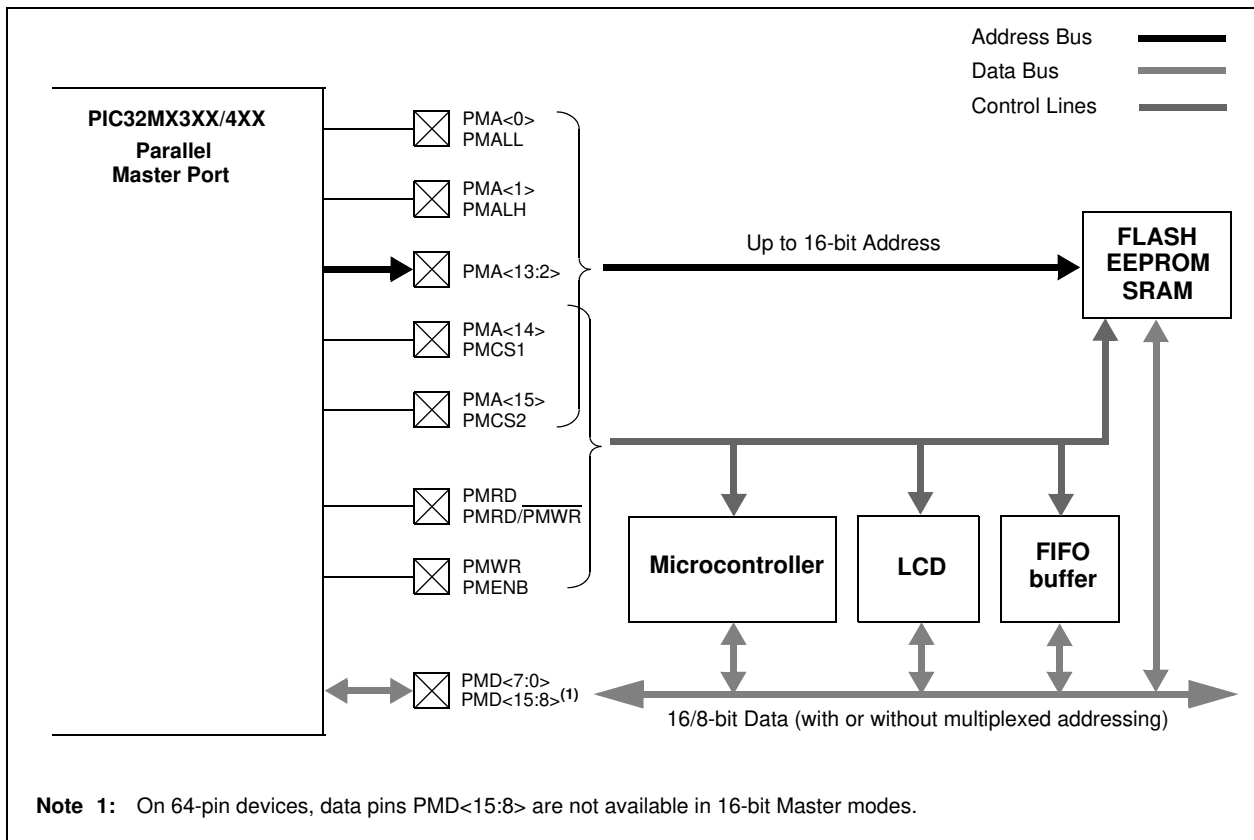

PIC32MX3XX/4XX

NOTES:

21.0 REAL-TIME CLOCK AND CALENDAR (RTCC)

Note 1: This data sheet summarizes the features of the PIC32MX3XX/4XX family of devices. It is not intended to be a comprehensive reference source. To complement the information in this data sheet, refer to **Section 29. “Real-Time Clock and Calendar (RTCC)”** (DS61125) of the “PIC32 Family Reference Manual”, which is available from the Microchip web site (www.microchip.com/PIC32).

2: Some registers and associated bits described in this section may not be available on all devices. Refer to **Section 4.0 “Memory Organization”** in this data sheet for device-specific register and bit information.

The PIC32MX RTCC module is intended for applications in which accurate time must be maintained for extended periods of time with minimal or no CPU intervention. Low-power optimization provides extended battery lifetime while keeping track of time.

The following are some of the key features of this module:

- Time: Hours, Minutes and Seconds
- 24-Hour Format (Military Time)
- Visibility of One-Half-Second Period
- Provides Calendar: Weekday, Date, Month and Year
- Alarm Intervals are configurable for Half of a Second, One Second, 10 Seconds, One Minute, 10 Minutes, One Hour, One Day, One Week, One Month and One Year
- Alarm Repeat with Decrementing Counter
- Alarm with Indefinite Repeat: Chime
- Year Range: 2000 to 2099
- Leap Year Correction
- BCD Format for Smaller Firmware Overhead
- Optimized for Long-Term Battery Operation
- Fractional Second Synchronization
- User Calibration of the Clock Crystal Frequency with Auto-Adjust
- Calibration Range: ± 0.66 Seconds Error per Month
- Calibrates up to 260 ppm of Crystal Error
- Requirements: External 32.768 kHz Clock Crystal
- Alarm Pulse or Seconds Clock Output on RTCC pin

FIGURE 21-1: RTCC BLOCK DIAGRAM

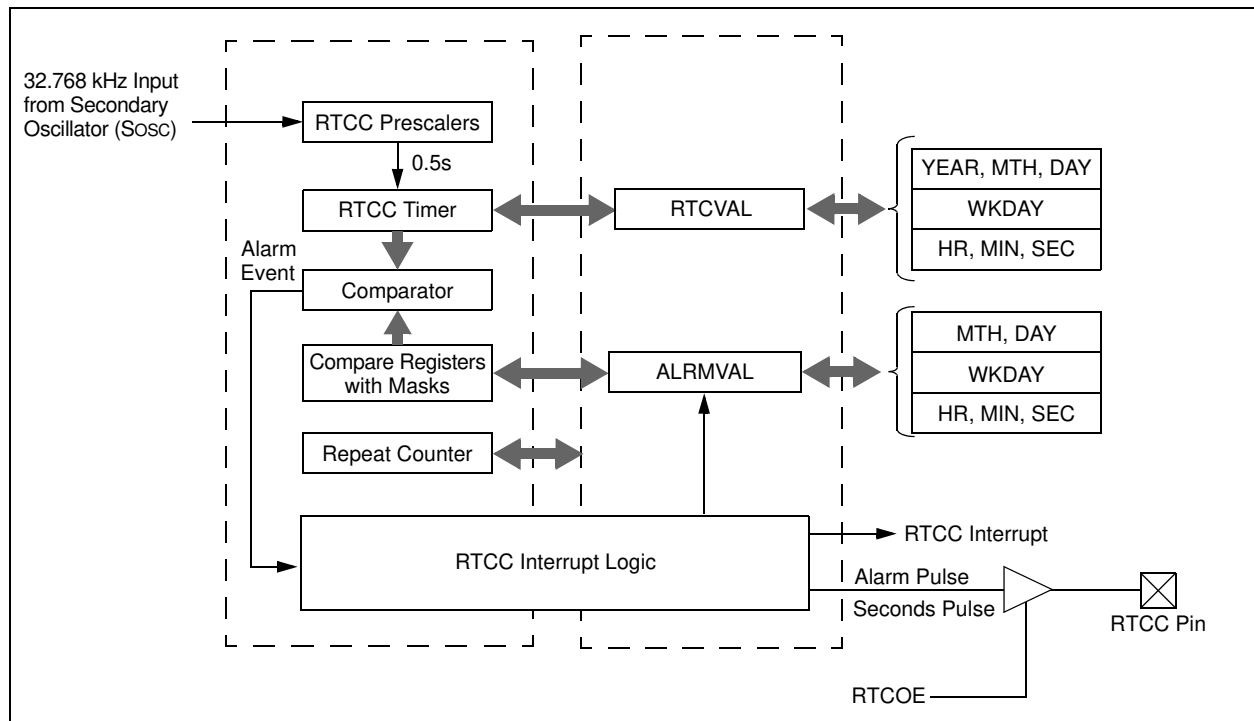

PIC32MX3XX/4XX

NOTES:

22.0 10-BIT ANALOG-TO-DIGITAL CONVERTER (ADC)

Note 1: This data sheet summarizes the features of the PIC32MX3XX/4XX family of devices. It is not intended to be a comprehensive reference source. Refer to **Section 17. “10-bit Analog-to-Digital Converter (ADC)”** (DS61104) of the “PIC32 Family Reference Manual”, which is available from the Microchip web site (www.microchip.com/PIC32).

2: Some registers and associated bits described in this section may not be available on all devices. Refer to **Section 4.0 “Memory Organization”** in this data sheet for device-specific register and bit information.

The PIC32MX3XX/4XX 10-bit Analog-to-Digital Converter (ADC) includes the following features:

- Successive Approximation Register (SAR) conversion
- Up to 1000 kilo samples per second (ksp/s) conversion speed
- Up to 16 analog input pins
- External voltage reference input pins
- One unipolar, differential Sample-and-Hold Amplifier (SHA)

- Automatic Channel Scan mode
- Selectable conversion trigger source
- 16-word conversion result buffer
- Selectable Buffer Fill modes
- Eight conversion result format options
- Operation during CPU Sleep and Idle modes

A block diagram of the 10-bit ADC is illustrated in **Figure 22-1**. The 10-bit ADC has 16 analog input pins, designated AN0-AN15. In addition, there are two analog input pins for external voltage reference connections. These voltage reference inputs may be shared with other analog input pins and may be common to other analog module references.

The analog inputs are connected through two multiplexers (MUXs) to one SHA. The analog input MUXs can be switched between two sets of analog inputs between conversions. Unipolar differential conversions are possible on all channels, other than the pin used as the reference, using a reference input pin (see **Figure 22-1**).

The Analog Input Scan mode sequentially converts user-specified channels. A control register specifies which analog input channels will be included in the scanning sequence.

The 10-bit ADC is connected to a 16-word result buffer. Each 10-bit result is converted to one of eight, 32-bit output formats when it is read from the result buffer.

FIGURE 22-1: ADC1 MODULE BLOCK DIAGRAM

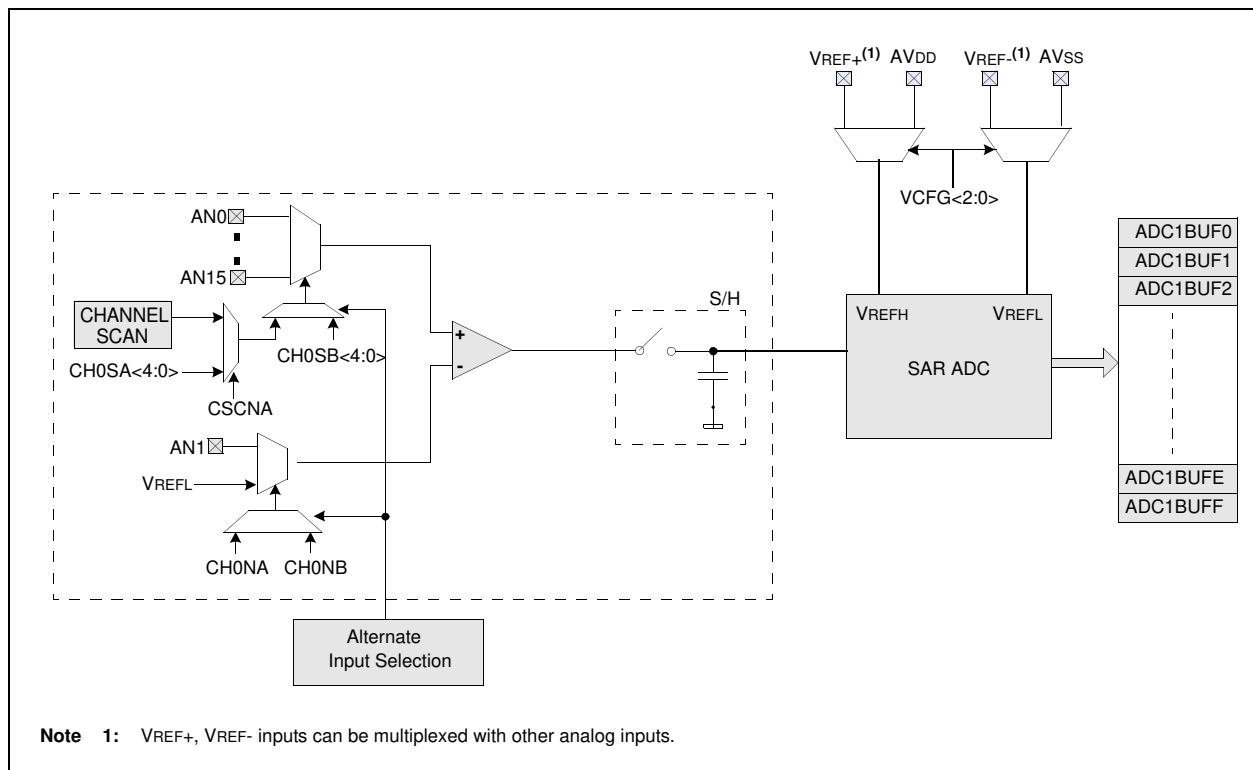

PIC32MX3XX/4XX

FIGURE 22-2: ADC CONVERSION CLOCK PERIOD BLOCK DIAGRAM

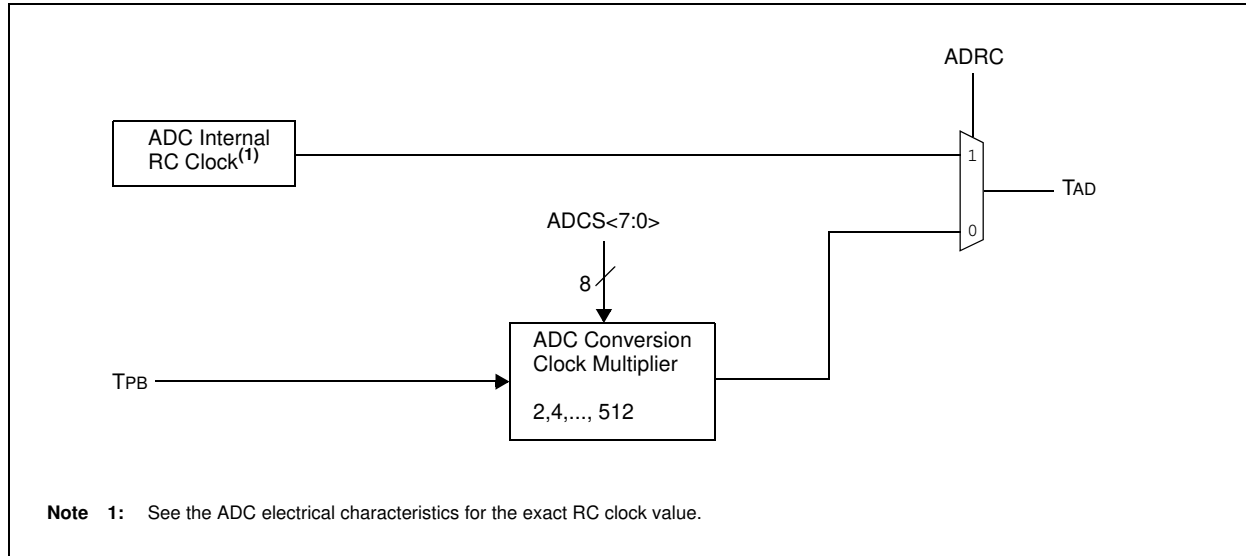

23.0 COMPARATOR

Note 1: This data sheet summarizes the features of the PIC32MX3XX/4XX family of devices. It is not intended to be a comprehensive reference source. Refer to **Section 19. "Comparator"** (DS61110) of the "PIC32 Family Reference Manual", which is available from the Microchip web site (www.microchip.com/PIC32).

2: Some registers and associated bits described in this section may not be available on all devices. Refer to **Section 4.0 "Memory Organization"** in this data sheet for device-specific register and bit information.

The PIC32MX3XX/4XX Analog Comparator module contains one or more comparator(s) that can be configured in a variety of ways.

Following are some of the key features of this module:

- Selectable inputs available include:
 - Analog inputs multiplexed with I/O pins
 - On-chip internal absolute voltage reference (IVREF)
 - Comparator voltage reference (CVREF)
- Outputs can be inverted
- Selectable interrupt generation

A block diagram of the comparator module is illustrated in [Figure 23-1](#).

FIGURE 23-1: COMPARATOR BLOCK DIAGRAM

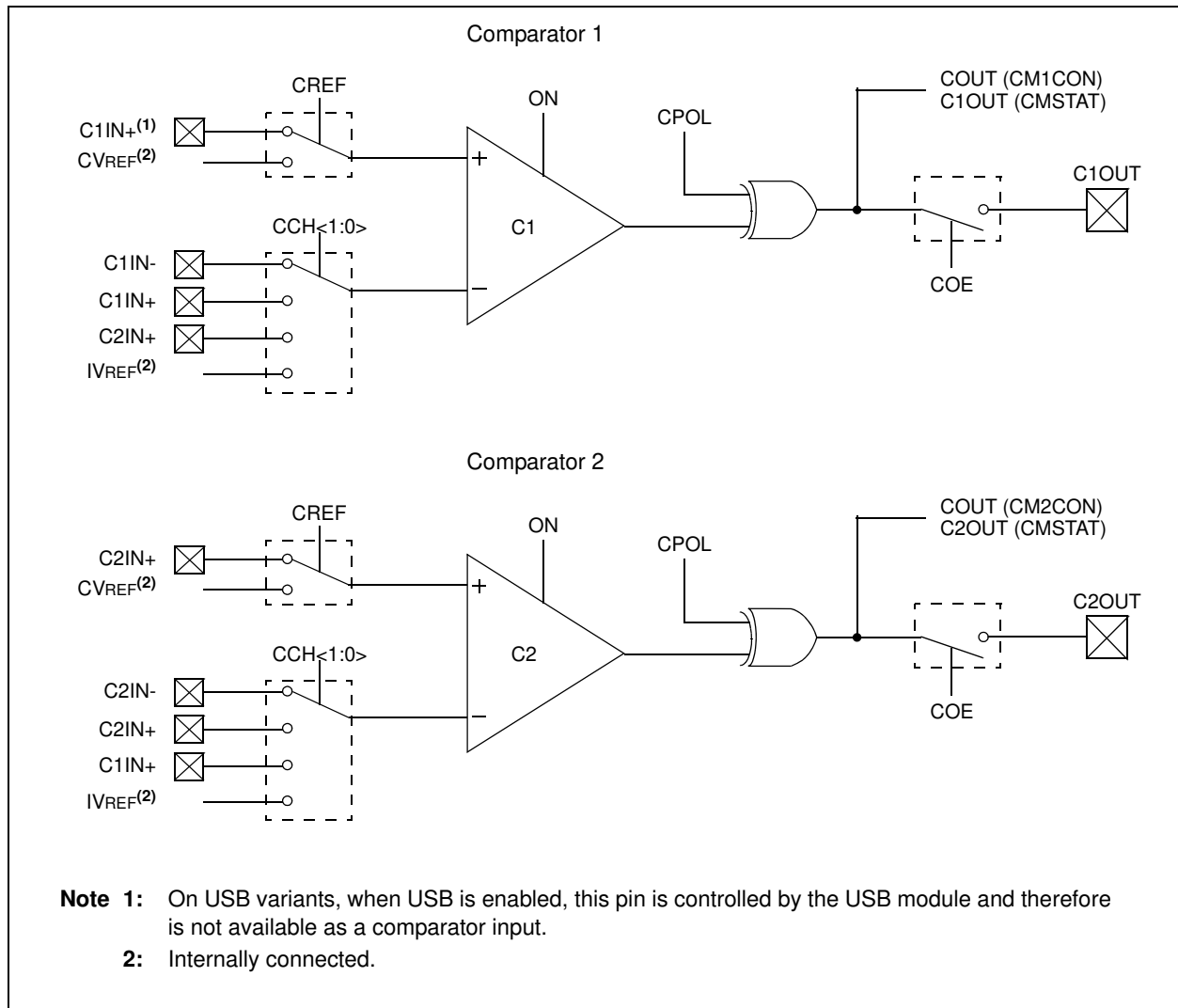

PIC32MX3XX/4XX

NOTES:

24.0 COMPARATOR VOLTAGE REFERENCE (CVREF)

Note 1: This data sheet summarizes the features of the PIC32MX3XX/4XX family of devices. It is not intended to be a comprehensive reference source. Refer to **Section 20. “Comparator Voltage Reference (CVREF)”** (DS61109) of the “PIC32 Family Reference Manual”, which is available from the Microchip web site (www.microchip.com/PIC32).

2: Some registers and associated bits described in this section may not be available on all devices. Refer to **Section 4.0 “Memory Organization”** in this data sheet for device-specific register and bit information.

The CVREF is a 16-tap, resistor ladder network that provides a selectable reference voltage. Although its primary purpose is to provide a reference for the analog comparators, it also may be used independently of them.

A block diagram of the module is illustrated in **Figure 24-1**. The resistor ladder is segmented to provide two ranges of voltage reference values and has a power-down function to conserve power when the reference is not being used. The module’s supply reference can be provided from either device VDD/VSS or an external voltage reference. The CVREF output is available for the comparators and typically available for pin output.

The comparator voltage reference has the following features:

- High and low range selection
- Sixteen output levels available for each range
- Internally connected to comparators to conserve device pins
- Output can be connected to a pin

FIGURE 24-1: COMPARATOR VOLTAGE REFERENCE BLOCK DIAGRAM

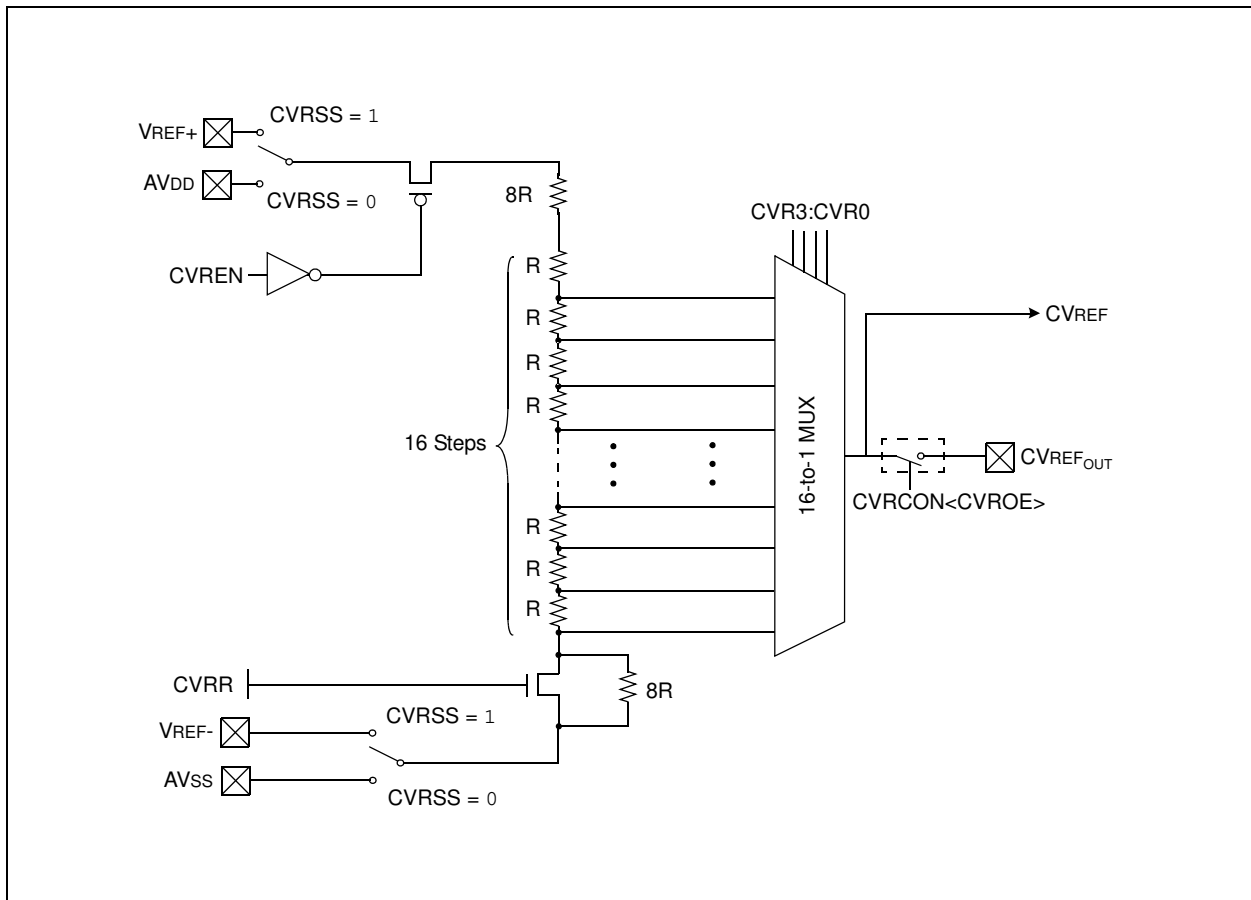

PIC32MX3XX/4XX

NOTES:

25.0 POWER-SAVING FEATURES

Note 1: This data sheet summarizes the features of the PIC32MX3XX/4XX family of devices. It is not intended to be a comprehensive reference source. To complement the information in this data sheet, refer to **Section 10. “Power-Saving Features”** (DS61130) of the *“PIC32 Family Reference Manual”*, which is available from the Microchip web site (www.microchip.com/PIC32).

2: Some registers and associated bits described in this section may not be available on all devices. Refer to **Section 4.0 “Memory Organization”** in this data sheet for device-specific register and bit information.

This section describes power-saving for the PIC32MX3XX/4XX. The PIC32MX devices offer a total of nine methods and modes that are organized into two categories that allow the user to balance power consumption with device performance. In all of the methods and modes described in this section, power-saving is controlled by software.

25.1 Power-Saving with CPU Running

When the CPU is running, power consumption can be controlled by reducing the CPU clock frequency, lowering the PBCLK, and by individually disabling modules. These methods are grouped into the following modes:

- FRC Run mode: the CPU is clocked from the FRC clock source with or without postscalers.
- LPRC Run mode: the CPU is clocked from the LPRC clock source.
- SOSC Run mode: the CPU is clocked from the SOSC clock source.
- Peripheral Bus Scaling mode: peripherals are clocked at programmable fraction of the CPU clock (SYSCLK).

25.2 CPU Halted Methods

The device supports two power-saving modes, Sleep and Idle, both of which halt the clock to the CPU. These modes operate with all clock sources, as listed below:

- Posc Idle Mode: the system clock is derived from the POSC. The system clock source continues to operate.
Peripherals continue to operate, but can optionally be individually disabled.
- FRC Idle Mode: the system clock is derived from the FRC with or without postscalers. Peripherals continue to operate, but can optionally be individually disabled.
- SOSC Idle Mode: the system clock is derived from the SOSC. Peripherals continue to operate, but can optionally be individually disabled.

- LPRC Idle Mode: the system clock is derived from the LPRC.
Peripherals continue to operate, but can optionally be individually disabled. This is the lowest power mode for the device with a clock running.
- Sleep Mode: the CPU, the system clock source, and any peripherals that operate from the system clock source, are halted.
Some peripherals can operate in Sleep using specific clock sources. This is the lowest power mode for the device.

25.3 Power-Saving Operation

The purpose of all power-saving is to reduce power consumption by reducing the device clock frequency. To achieve this, low-frequency clock sources can be selected. In addition, the peripherals and CPU can be halted or disabled to further reduce power consumption.

25.3.1 SLEEP MODE

Sleep mode has the lowest power consumption of the device Power-Saving operating modes. The CPU and most peripherals are halted. Select peripherals can continue to operate in Sleep mode and can be used to wake the device from Sleep. See the individual peripheral module sections for descriptions of behavior in Sleep mode.

Sleep mode includes the following characteristics:

- The CPU is halted.
- The system clock source is typically shut down. See **Section 25.3.2 “Idle Mode”** for specific information.
- There can be a wake-up delay based on the oscillator selection.
- The Fail-Safe Clock Monitor (FSCM) does not operate during Sleep mode.
- The BOR circuit, if enabled, remains operative during Sleep mode.
- The WDT, if enabled, is not automatically cleared prior to entering Sleep mode.
- Some peripherals can continue to operate in Sleep mode. These peripherals include I/O pins that detect a change in the input signal, WDT, ADC, UART and peripherals that use an external clock input or the internal LPRC oscillator, e.g., RTCC and Timer 1.
- I/O pins continue to sink or source current in the same manner as they do when the device is not in Sleep.
- The USB module can override the disabling of the POSC or FRC. Refer to **Section 11.0 “USB On-The-Go (OTG)”** for specific details.
- Some modules can be individually disabled by software prior to entering Sleep in order to further reduce consumption.

PIC32MX3XX/4XX

The processor will exit, or 'wake-up', from Sleep on one of the following events:

- On any interrupt from an enabled source that is operating in Sleep. The interrupt priority must be greater than the current CPU priority.
- On any form of device Reset.
- On a WDT time-out. See [Section 26.2 “Watchdog Timer \(WDT\)”](#).

If the interrupt priority is lower than or equal to current priority, the CPU will remain halted, but the PBCLK will start running and the device will enter into Idle mode.

Note: There is no FRZ mode for this module.

25.3.2 IDLE MODE

In the Idle mode, the CPU is halted but the System clock (SYSCLK) source is still enabled. This allows peripherals to continue operation when the CPU is halted. Peripherals can be individually configured to halt when entering Idle by setting their respective SIDL bit. Latency when exiting Idle mode is very low due to the CPU oscillator source remaining active.

Note: Changing the PBCLK divider ratio requires recalculation of peripheral timing. For example, assume the UART is configured for 9600 baud with a PB clock ratio of 1:1 and a POSC of 8 MHz. When the PB clock divisor of 1:2 is used, the input frequency to the baud clock is cut in half; therefore, the baud rate is reduced to 1/2 its former value. Due to numeric truncation in calculations (such as the baud rate divisor), the actual baud rate may be a tiny percentage different than expected. For this reason, any timing calculation required for a peripheral should be performed with the new PB clock frequency instead of scaling the previous value based on a change in PB divisor ratio.

Oscillator start-up and PLL lock delays are applied when switching to a clock source that was disabled and that uses a crystal and/or the PLL. For example, assume the clock source is switched from POSC to LPRC just prior to entering Sleep in order to save power. No oscillator start-up delay would be applied when exiting Idle. However, when switching back to POSC, the appropriate PLL and/or oscillator startup/lock delays would be applied.

The device enters Idle mode when the SLPEN (OSCCON<4>) bit is clear and a WAIT instruction is executed.

The processor will wake or exit from Idle mode on the following events:

- On any interrupt event for which the interrupt source is enabled. The priority of the interrupt event must be greater than the current priority of CPU. If the priority of the interrupt event is lower than or equal to current priority of CPU, the CPU will remain halted and the device will remain in Idle mode.
- On any source of device Reset.
- On a WDT time-out interrupt. See [Section 26.2 “Watchdog Timer \(WDT\)”](#).

25.3.3 PERIPHERAL BUS SCALING METHOD

Most of the peripherals on the device are clocked using the PBCLK. The peripheral bus can be scaled relative to the SYSCLK to minimize the dynamic power consumed by the peripherals. The PBCLK divisor is controlled by PBDIV<1:0> (OSCCON<20:19>), allowing SYSCLK-to-PBCLK ratios of 1:1, 1:2, 1:4 and 1:8. All peripherals using PBCLK are affected when the divisor is changed. Peripherals such as USB, Interrupt Controller, DMA, Bus Matrix and Prefetch Cache are clocked directly from SYSCLK, as a result, they are not affected by PBCLK divisor changes

Changing the PBCLK divisor affects:

- The CPU to peripheral access latency. The CPU has to wait for next PBCLK edge for a read to complete. In 1:8 mode this results in a latency of one to seven SYSCLKs.
- The power consumption of the peripherals. Power consumption is directly proportional to the frequency at which the peripherals are clocked. The greater the divisor, the lower the power consumed by the peripherals.

To minimize dynamic power the PB divisor should be chosen to run the peripherals at the lowest frequency that provides acceptable system performance. When selecting a PBCLK divider, peripheral clock requirements such as baud rate accuracy should be taken into account. For example, the UART peripheral may not be able to achieve all baud rate values at some PBCLK divider depending on the SYSCLK value.

26.0 SPECIAL FEATURES

Note: This data sheet summarizes the features of the PIC32MX3XX/4XX family of devices. It is not intended to be a comprehensive reference source. To complement the information in this data sheet, refer to **Section 9. “Watchdog Timer and Power-up Timer”** (DS61114), **Section 32. “Configuration”** (DS61124) and **Section 33. “Programming and Diagnostics”** (DS61129) of the *“PIC32 Family Reference Manual”*, which is available from the Microchip web site (www.microchip.com/PIC32).

PIC32MX3XX/4XX devices include several features intended to maximize application flexibility and reliability and minimize cost through elimination of external components. These are:

- Flexible Device Configuration
- Watchdog Timer
- JTAG Interface
- In-Circuit Serial Programming™ (ICSP™)

26.1 Configuration Bits

The Configuration bits can be programmed to select various device configurations.

REGISTER 26-1: DEVCFG0: DEVICE CONFIGURATION WORD 0

| Bit Range | Bit 31/23/15/7 | Bit 30/22/14/6 | Bit 29/21/13/5 | Bit 28/20/12/4 | Bit 27/19/11/3 | Bit 26/18/10/2 | Bit 25/17/9/1 | Bit 24/16/8/0 |
|-----------|----------------|----------------|----------------|----------------|----------------|----------------|---------------|---------------|
| 31:24 | r-0 | r-1 | r-1 | R/P | r-1 | r-1 | r-1 | R/P |
| | — | — | — | CP | — | — | — | BWP |
| 23:16 | r-1 | r-1 | r-1 | r-1 | R/P | R/P | R/P | R/P |
| | — | — | — | — | PWP<7:4> | | | |
| 15:8 | R/P | R/P | R/P | R/P | r-1 | r-1 | r-1 | r-1 |
| | PWP<3:0> | | | | — | — | — | — |
| 7:0 | r-1 | r-1 | r-1 | r-1 | R/P | r-1 | R/P | R/P |
| | — | — | — | — | ICSEL | — | DEBUG<1:0> | |

Legend:

R = Readable bit W = Writable bit P = Programmable bit r = Reserved bit
 U = Unimplemented bit -n = Bit Value at POR: ('0', '1', x = Unknown)

- bit 31 **Reserved:** Write '0'
- bit 30-29 **Reserved:** Write '1'
- bit 28 **CP:** Code-Protect bit
 Prevents boot and program Flash memory from being read or modified by an external programming device.
 1 = Protection disabled
 0 = Protection enabled
- bit 27-25 **Reserved:** Write '1'
- bit 24 **BWP:** Boot Flash Write-Protect bit
 Prevents boot Flash memory from being modified during code execution.
 1 = Boot Flash is writable
 0 = Boot Flash is not writable
- bit 23-20 **Reserved:** Write '1'

PIC32MX3XX/4XX

REGISTER 26-1: DEVCFG0: DEVICE CONFIGURATION WORD 0 (CONTINUED)

bit 19-12 **PWP<7:0>**: Program Flash Write-Protect bits

Prevents selected program Flash memory pages from being modified during code execution. The PWP bits represent the one's complement of the number of write protected program Flash memory pages.

11111111 = Disabled
11111110 = 0xBD00_0FFF
11111101 = 0xBD00_1FFF
11111100 = 0xBD00_2FFF
11111011 = 0xBD00_3FFF
11111010 = 0xBD00_4FFF
11111001 = 0xBD00_5FFF
11111000 = 0xBD00_6FFF
11110111 = 0xBD00_7FFF
11110110 = 0xBD00_8FFF
11110101 = 0xBD00_9FFF
11110100 = 0xBD00_AFFF
11110011 = 0xBD00_BFFF
11110010 = 0xBD00_CFFF
11110001 = 0xBD00_DFFF
11110000 = 0xBD00_EFFF
11101111 = 0xBD00_FFFF
.
.
.
01111111 = 0xBD07_FFFF

bit 11-4 **Reserved**: Write '1'

bit 3 **ICESEL**: In-Circuit Emulator/Debugger Communication Channel Select bit

1 = PGEC2/PGED2 pair is used
0 = PGEC1/PGED1 pair is used

bit 2 **Reserved**: Write '1'

bit 1-0 **DEBUG<1:0>**: Background Debugger Enable bits (forced to '11' if code-protect is enabled)

11 = Debugger disabled
10 = Debugger enabled
01 = Reserved (same as '11' setting)
00 = Reserved (same as '11' setting)

REGISTER 26-2: DEVCFG1: DEVICE CONFIGURATION WORD 1

| Bit Range | Bit 31/23/15/7 | Bit 30/22/14/6 | Bit 29/21/13/5 | Bit 28/20/12/4 | Bit 27/19/11/3 | Bit 26/18/10/2 | Bit 25/17/9/1 | Bit 24/16/8/0 |
|-----------|----------------|----------------|----------------|----------------|----------------|----------------|---------------|---------------|
| 31:24 | r-1 | r-1 | r-1 | r-1 | r-1 | r-1 | r-1 | r-1 |
| | — | — | — | — | — | — | — | — |
| 23:16 | R/P | r-1 | r-1 | R/P | R/P | R/P | R/P | R/P |
| | FWDTEN | — | — | WDTPS<4:0> | | | | |
| 15:8 | R/P | R/P | R/P | R/P | r-1 | R/P | R/P | R/P |
| | FCKSM<1:0> | | FPBDIV<1:0> | | — | OSCIOFNC | POSCMOD<1:0> | |
| 7:0 | R/P | r-1 | R/P | r-1 | r-1 | R/P | R/P | R/P |
| | IESO | — | FSOSCEN | — | — | FNOSC<2:0> | | |

Legend:

R = Readable bit W = Writable bit P = Programmable bit r = Reserved bit
 U = Unimplemented bit -n = Bit Value at POR: ('0', '1', x = Unknown)

bit 31-24 **Reserved:** Write '1'

bit 23 **FWDTEN:** Watchdog Timer Enable bit

1 = The WDT is enabled and cannot be disabled by software
 0 = The WDT is not enabled; it can be enabled in software

bit 22-21 **Reserved:** Write '1'

bit 20-16 **WDTPS<4:0>:** Watchdog Timer Postscale Select bits

10100 = 1:1048576
 10011 = 1:524288
 10010 = 1:262144
 10001 = 1:131072
 10000 = 1:65536
 01111 = 1:32768
 01110 = 1:16384
 01101 = 1:8192
 01100 = 1:4096
 01011 = 1:2048
 01010 = 1:1024
 01001 = 1:512
 01000 = 1:256
 00111 = 1:128
 00110 = 1:64
 00101 = 1:32
 00100 = 1:16
 00011 = 1:8
 00010 = 1:4
 00001 = 1:2
 00000 = 1:1

All other combinations not shown result in operation = '10100'

bit 15-14 **FCKSM<1:0>:** Clock Switching and Monitor Selection Configuration bits

1x = Clock switching is disabled, Fail-Safe Clock Monitor is disabled
 01 = Clock switching is enabled, Fail-Safe Clock Monitor is disabled
 00 = Clock switching is enabled, Fail-Safe Clock Monitor is enabled

Note 1: Do not disable Posc (POSCMOD = 00) when using this oscillator source.

PIC32MX3XX/4XX

REGISTER 26-2: DEVCFG1: DEVICE CONFIGURATION WORD 1 (CONTINUED)

- bit 13-12 **FPBDIV<1:0>**: Peripheral Bus Clock Divisor Default Value bits
11 = PBCLK is SYSCLK divided by 8
10 = PBCLK is SYSCLK divided by 4
01 = PBCLK is SYSCLK divided by 2
00 = PBCLK is SYSCLK divided by 1
- bit 11 **Reserved**: Write '1'
- bit 10 **OSCIOFNC**: CLKO Enable Configuration bit
1 = CLKO output signal active on the OSCO pin; primary oscillator must be disabled or configured for the External Clock mode (EC) for the CLKO to be active (POSCMOD<1:0> = 11 OR 00)
0 = CLKO output disabled
- bit 9-8 **POSCMOD<1:0>**: Primary Oscillator Configuration bits
11 = Primary oscillator disabled
10 = HS oscillator mode selected
01 = XT oscillator mode selected
00 = External clock mode selected
- bit 7 **IESO**: Internal External Switchover bit
1 = Internal External Switchover mode enabled (Two-Speed Start-up enabled)
0 = Internal External Switchover mode disabled (Two-Speed Start-up disabled)
- bit 6 **Reserved**: Write '1'
- bit 5 **FSOSCEN**: Secondary Oscillator Enable bit
1 = Enable Secondary Oscillator
0 = Disable Secondary Oscillator
- bit 4-3 **Reserved**: Write '1'
- bit 2-0 **FNOSC<2:0>**: Oscillator Selection bits
111 = Fast RC Oscillator with divide-by-N (FRCDIV)
110 = FRCDIV16 Fast RC Oscillator with fixed divide-by-16 postscaler
101 = Low-Power RC Oscillator (LPRC)
100 = Secondary Oscillator (SOSC)
011 = Primary Oscillator with PLL module (XT+PLL, HS+PLL, EC+PLL)
010 = Primary Oscillator (XT, HS, EC)⁽¹⁾
001 = Fast RC Oscillator with divide-by-N with PLL module (FRCDIV+PLL)
000 = Fast RC Oscillator (FRC)

Note 1: Do not disable Posc (POSCMOD = 00) when using this oscillator source.

REGISTER 26-3: DEVCFG2: DEVICE CONFIGURATION WORD 2

| Bit Range | Bit 31/23/15/7 | Bit 30/22/14/6 | Bit 29/21/13/5 | Bit 28/20/12/4 | Bit 27/19/11/3 | Bit 26/18/10/2 | Bit 25/17/9/1 | Bit 24/16/8/0 |
|-----------|----------------|---------------------|----------------|----------------|----------------|----------------------|---------------|---------------------|
| 31:24 | r-1 — | r-1 — | r-1 — | r-1 — | r-1 — | r-1 — | r-1 — | r-1 — |
| 23:16 | r-1 — | r-1 — | r-1 — | r-1 — | r-1 — | R/P FPLLODIV<2:0> | R/P | R/P |
| 15:8 | R/P UPLLEN | r-1 — | r-1 — | r-1 — | r-1 — | R/P UPLLDIV<2:0> | R/P | R/P |
| 7:0 | r-1 — | R/P FPLLMUL<2:0> | R/P | R/P | r-1 | R/P | R/P | R/P FPLLDIV<2:0> |

Legend:

R = Readable bit W = Writable bit P = Programmable bit r = Reserved bit
 U = Unimplemented bit -n = Bit Value at POR: ('0', '1', x = Unknown)

bit 31-19 **Reserved:** Write '1'

bit 18-16 **FPLLODIV<2:0>:** Default Postscaler for PLL bits

- 111 = PLL output divided by 256
- 110 = PLL output divided by 64
- 101 = PLL output divided by 32
- 100 = PLL output divided by 16
- 011 = PLL output divided by 8
- 010 = PLL output divided by 4
- 001 = PLL output divided by 2
- 000 = PLL output divided by 1

bit 15 **UPLLEN:** USB PLL Enable bit
 1 = Disable and bypass USB PLL
 0 = Enable USB PLL

bit 14-11 **Reserved:** Write '1'

bit 10-8 **UPLLDIV<2:0>:** PLL Input Divider bits

- 111 = 12x divider
- 110 = 10x divider
- 101 = 6x divider
- 100 = 5x divider
- 011 = 4x divider
- 010 = 3x divider
- 010 = 3x divider
- 001 = 2x divider
- 000 = 1x divider

bit 7 **Reserved:** Write '1'

bit 6-4 **FPLLMUL<2:0>:** PLL Multiplier bits

- 111 = 24x multiplier
- 110 = 21x multiplier
- 101 = 20x multiplier
- 100 = 19x multiplier
- 011 = 18x multiplier
- 010 = 17x multiplier
- 001 = 16x multiplier
- 000 = 15x multiplier

bit 3 **Reserved:** Write '1'

bit 2-0 **FPLLDIV<2:0>:** PLL Input Divider bits

- 111 = 12x divider
- 110 = 10x divider
- 101 = 6x divider
- 100 = 5x divider
- 011 = 4x divider
- 010 = 3x divider
- 001 = 2x divider
- 000 = 1x divider

PIC32MX3XX/4XX

REGISTER 26-4: DEVCFG3: DEVICE CONFIGURATION WORD 3

| Bit Range | Bit 31/23/15/7 | Bit 30/22/14/6 | Bit 29/21/13/5 | Bit 28/20/12/4 | Bit 27/19/11/3 | Bit 26/18/10/2 | Bit 25/17/9/1 | Bit 24/16/8/0 |
|-----------|----------------|----------------|----------------|----------------|----------------|----------------|---------------|---------------|
| 31:24 | r-1 | r-1 | r-1 | r-1 | r-1 | r-1 | r-1 | r-1 |
| | — | — | — | — | — | — | — | — |
| 23:16 | r-1 | r-1 | r-1 | r-1 | r-1 | r-1 | r-1 | r-1 |
| | — | — | — | — | — | — | — | — |
| 15:8 | R/P | R/P | R/P | R/P | R/P | R/P | R/P | R/P |
| | USERID<15:8> | | | | | | | |
| 7:0 | R/P | R/P | R/P | R/P | R/P | R/P | R/P | R/P |
| | USERID<7:0> | | | | | | | |

Legend:

R = Readable bit W = Writable bit P = Programmable bit r = Reserved bit
 U = Unimplemented bit -n = Bit Value at POR: ('0', '1', x = Unknown)

bit 31-16 **Reserved:** Write '1'

bit 15-0 **USERID<15:0>:** This is a 16-bit value that is user defined and is readable via ICSP™ and JTAG

REGISTER 26-5: DEVID: DEVICE AND REVISION ID REGISTER

| Bit Range | Bit 31/23/15/7 | Bit 30/22/14/6 | Bit 29/21/13/5 | Bit 28/20/12/4 | Bit 27/19/11/3 | Bit 26/18/10/2 | Bit 25/17/9/1 | Bit 24/16/8/0 |
|-----------|-----------------------------|----------------|----------------|----------------|-----------------------------|----------------|---------------|---------------|
| 31:24 | R | R | R | R | R | R | R | R |
| | VER<3:0> ⁽¹⁾ | | | | DEVID<27:24> ⁽¹⁾ | | | |
| 23:16 | R | R | R | R | R | R | R | R |
| | DEVID<23:16> ⁽¹⁾ | | | | | | | |
| 15:8 | R | R | R | R | R | R | R | R |
| | DEVID<15:8> ⁽¹⁾ | | | | | | | |
| 7:0 | R | R | R | R | R | R | R | R |
| | DEVID<7:0> ⁽¹⁾ | | | | | | | |

Legend:

R = Readable bit W = Writable bit P = Programmable bit r = Reserved bit
 U = Unimplemented bit -n = Bit Value at POR: ('0', '1', x = Unknown)

bit 31-28 **VER<3:0>:** Revision Identifier bits⁽¹⁾

bit 27-0 **DEVID<27:0>:** Device ID⁽¹⁾

Note 1: See the "PIC32MX Flash Programming Specification" (DS61145) for a list of Revision and Device ID values.

26.2 Watchdog Timer (WDT)

This section describes the operation of the WDT and Power-Up Timer of the PIC32MX3XX/4XX.

The WDT, when enabled, operates from the internal Low-Power Oscillator (LPRC) clock source and can be used to detect system software malfunctions by resetting the device if the WDT is not cleared periodically in software. Various WDT time-out periods can be selected using the WDT postscaler. The WDT can also be used to wake the device from Sleep or Idle mode.

The following are some of the key features of the WDT module:

- Configuration or software controlled
- User-configurable time-out period
- Can wake the device from Sleep or Idle

FIGURE 26-1: WATCHDOG AND POWER-UP TIMER BLOCK DIAGRAM

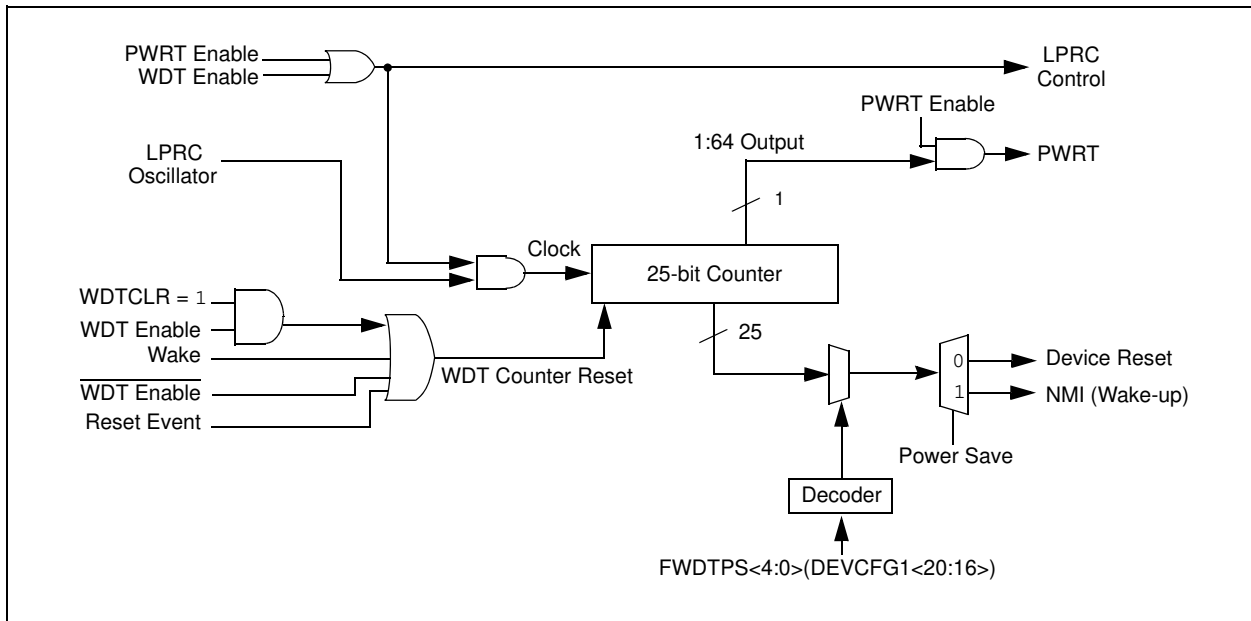

PIC32MX3XX/4XX

26.3 On-Chip Voltage Regulator

All PIC32MX3XX/4XX device's core and digital logic are designed to operate at a nominal 1.8V. To simplify system designs, most devices in the PIC32MX3XX/4XX incorporate an on-chip regulator providing the required core logic voltage from VDD.

The internal 1.8V regulator is controlled by the ENVREG pin. Tying this pin to VDD enables the regulator, which in turn provides power to the core. A low ESR capacitor (such as tantalum) must be connected to the V_{CORE}/V_{CAP} pin (Figure 26-2). This helps to maintain the stability of the regulator. The recommended value for the filter capacitor is provided in Section 29.1 "DC Characteristics".

Note: It is important that the low ESR capacitor is placed as close as possible to the V_{CORE}/V_{CAP} pin.

Tying the ENVREG pin to VSS disables the regulator. In this case, separate power for the core logic at a nominal 1.8V must be supplied to the device on the V_{CORE}/V_{CAP} pin.

Alternatively, the V_{CORE}/V_{CAP} and VDD pins can be tied together to operate at a lower nominal voltage. Refer to Figure 26-2 for possible configurations.

26.3.1 ON-CHIP REGULATOR AND POR

When the voltage regulator is enabled, it takes fixed delay for it to generate output. During this time, designated as T_{PU}, code execution is disabled. T_{PU} is applied every time the device resumes operation after any power-down, including Sleep mode.

If the regulator is disabled, a separate Power-up Timer (PWRT) is automatically enabled. The PWRT adds a fixed delay of T_{PWRT} at device start-up. See Section 29.0 "Electrical Characteristics" for more information on T_{PU} AND T_{PWRT}.

26.3.2 ON-CHIP REGULATOR AND BOR

When the on-chip regulator is enabled, PIC32MX3XX/4XX devices also have a simple brown-out capability. If the voltage supplied to the regulator is inadequate to maintain a regulated level, the regulator Reset circuitry will generate a Brown-out Reset. This event is captured by the BOR flag bit (RCON<1>). The brown-out voltage levels are specific in Section 29.1 "DC Characteristics".

26.3.3 POWER-UP REQUIREMENTS

The on-chip regulator is designed to meet the power-up requirements for the device. If the application does not use the regulator, then strict power-up conditions must be adhered to. While powering up, V_{CORE} must never exceed VDD by 0.3 volts.

FIGURE 26-2: CONNECTIONS FOR THE ON-CHIP REGULATOR

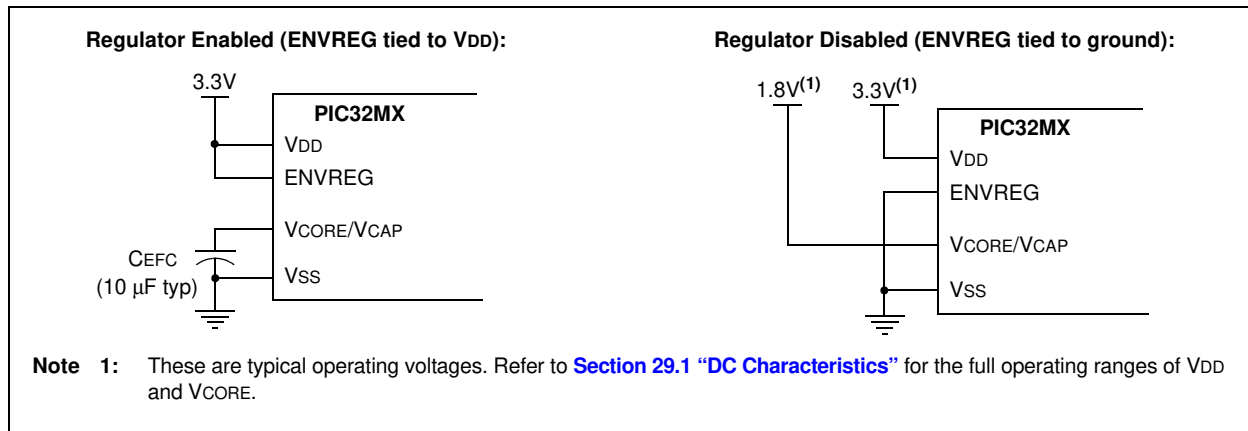

26.4 Programming and Diagnostics

PIC32MX3XX/4XX devices provide a complete range of programming and diagnostic features that can increase the flexibility of any application using them.

These features allow system designers to include:

- Simplified field programmability using two-wire In-Circuit Serial Programming™ (ICSP™) interfaces
- Debugging using ICSP
- Programming and debugging capabilities using the EJTAG extension of JTAG
- JTAG boundary scan testing for device and board diagnostics

PIC32MX devices incorporate two programming and diagnostic modules, and a trace controller, that provide a range of functions to the application developer.

FIGURE 26-3: BLOCK DIAGRAM OF PROGRAMMING, DEBUGGING AND TRACE PORTS

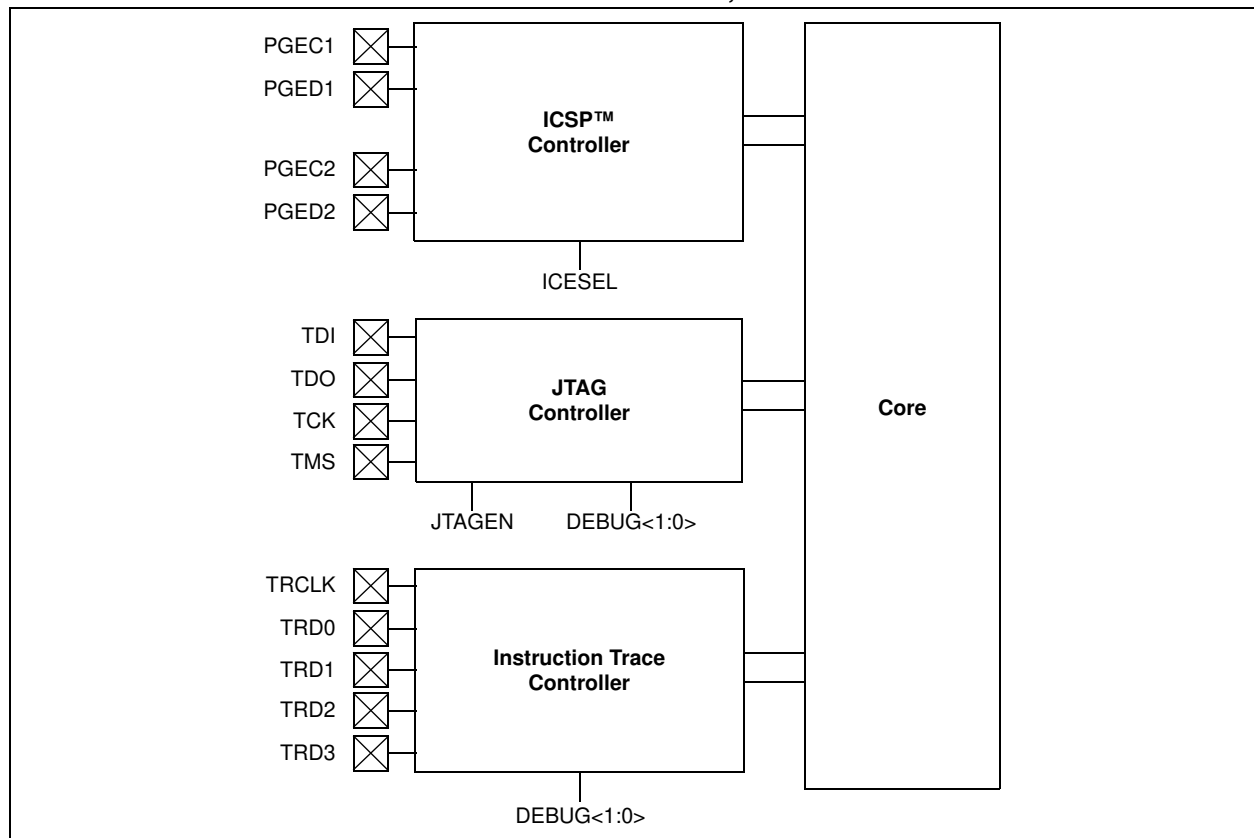

PIC32MX3XX/4XX

REGISTER 26-6: DDPCON: DEBUG DATA PORT CONTROL REGISTER

| Bit Range | Bit 31/23/15/7 | Bit 30/22/14/6 | Bit 29/21/13/5 | Bit 28/20/12/4 | Bit 27/19/11/3 | Bit 26/18/10/2 | Bit 25/17/9/1 | Bit 24/16/8/0 |
|-----------|----------------|----------------|----------------|----------------|----------------|----------------|---------------|---------------|
| 31:24 | r-x | r-x | r-x | r-x | r-x | r-x | r-x | r-x |
| | — | — | — | — | — | — | — | — |
| 23:16 | r-x | r-x | r-x | r-x | r-x | r-x | r-x | r-x |
| | — | — | — | — | — | — | — | — |
| 15:8 | r-x | r-x | r-x | r-x | r-x | r-x | r-x | r-x |
| | — | — | — | — | — | — | — | — |
| 7:0 | R/W-0 | R/W-0 | R/W-0 | R/W-0 | R/W-1 | R/W-0 | r-x | r-x |
| | DDPUSB | DDPU1 | DDPU2 | DDPSP1 | JTAGEN | TROEN | — | — |

Legend:

R = Readable bit W = Writable bit P = Programmable bit r = Reserved bit
 U = Unimplemented bit -n = Bit Value at POR: ('0', '1', x = Unknown)

- bit 31-8 **Reserved:** Write '0'; ignore read
- bit 7 **DDPUSB:** Debug Data Port Enable for USB bit
 1 = USB peripheral ignores USBFRZ (U1CNFG1<5>) setting
 0 = USB peripheral follows USBFRZ setting
- bit 6 **DDPU1:** Debug Data Port Enable for UART1 bit
 1 = UART1 peripheral ignores FRZ (U1MODE<14>) setting
 0 = UART1 peripheral follows FRZ setting
- bit 5 **DDPU2:** Debug Data Port Enable for UART2 bit
 1 = UART2 peripheral ignores FRZ (U2MODE<14>) setting
 0 = UART2 peripheral follows FRZ setting
- bit 4 **DDPSP1:** Debug Data Port Enable for SPI1 bit
 1 = SPI1 peripheral ignores FRZ (SPI1CON<14>) setting
 0 = SPI1 peripheral follows FRZ setting
- bit 3 **JTAGEN:** JTAG Port Enable bit
 1 = Enable JTAG Port
 0 = Disable JTAG Port
- bit 2 **TROEN:** Trace Output Enable bit
 1 = Enable Trace Port
 0 = Disable Trace Port
- bit 1-0 **Reserved:** Write '1'; ignore read

27.0 INSTRUCTION SET

The PIC32MX3XX/4XX family instruction set complies with the MIPS32 Release 2 instruction set architecture. PIC32MX does not support the following features:

- CoreExtend instructions
- Coprocessor 1 instructions
- Coprocessor 2 instructions

Table 27-1 provides a summary of the instructions that are implemented by the PIC32MX3XX/4XX family core.

Note: Refer to “MIPS32® Architecture for Programmers Volume II: The MIPS32® Instruction Set” at www.mips.com for more information.

TABLE 27-1: MIPS32® INSTRUCTION SET

| Instruction | Description | Function |
|-------------|--|--|
| ADD | Integer Add | $Rd = Rs + Rt$ |
| ADDI | Integer Add Immediate | $Rt = Rs + \text{Immed}$ |
| ADDIU | Unsigned Integer Add Immediate | $Rt = Rs +_U \text{Immed}$ |
| ADDU | Unsigned Integer Add | $Rd = Rs +_U Rt$ |
| AND | Logical AND | $Rd = Rs \& Rt$ |
| ANDI | Logical AND Immediate | $Rt = Rs \& (0_{16} \parallel \text{Immed})$ |
| B | Unconditional Branch (Assembler idiom for: BEQ r0, r0, offset) | $PC += (\text{int})\text{offset}$ |
| BAL | Branch and Link (Assembler idiom for: BGEZAL r0, offset) | $GPR[31] = PC + 8$ $PC += (\text{int})\text{offset}$ |
| BEQ | Branch on Equal | if $Rs == Rt$ $PC += (\text{int})\text{offset}$ |
| BEQL | Branch on Equal Likely ⁽¹⁾ | if $Rs == Rt$ $PC += (\text{int})\text{offset}$ else Ignore Next Instruction |
| BGEZ | Branch on Greater Than or Equal to Zero | if $!Rs[31]$ $PC += (\text{int})\text{offset}$ |
| BGEZAL | Branch on Greater Than or Equal to Zero and Link | $GPR[31] = PC + 8$ if $!Rs[31]$ $PC += (\text{int})\text{offset}$ |
| BGEZALL | Branch on Greater Than or Equal to Zero and Link Likely ⁽¹⁾ | $GPR[31] = PC + 8$ if $!Rs[31]$ $PC += (\text{int})\text{offset}$ else Ignore Next Instruction |
| BGEZL | Branch on Greater Than or Equal to Zero Likely ⁽¹⁾ | if $!Rs[31]$ $PC += (\text{int})\text{offset}$ else Ignore Next Instruction |
| BGTZ | Branch on Greater Than Zero | if $!Rs[31] \&\& Rs != 0$ $PC += (\text{int})\text{offset}$ |
| BGTZL | Branch on Greater Than Zero Likely ⁽¹⁾ | if $!Rs[31] \&\& Rs != 0$ $PC += (\text{int})\text{offset}$ else Ignore Next Instruction |
| BLEZ | Branch on Less Than or Equal to Zero | if $Rs[31] \parallel Rs == 0$ $PC += (\text{int})\text{offset}$ |

Note 1: This instruction is deprecated and should not be used.

PIC32MX3XX/4XX

TABLE 27-1: MIPS32® INSTRUCTION SET (CONTINUED)

| Instruction | Description | Function |
|-------------|--|---|
| BLEZL | Branch on Less Than or Equal to Zero Likely ⁽¹⁾ | if Rs[31] Rs == 0 PC += (int)offset else Ignore Next Instruction |
| BLTZ | Branch on Less Than Zero | if Rs[31] PC += (int)offset |
| BLTZAL | Branch on Less Than Zero and Link | GPR[31] = PC + 8 if Rs[31] PC += (int)offset |
| BLTZALL | Branch on Less Than Zero and Link Likely ⁽¹⁾ | GPR[31] = PC + 8 if Rs[31] PC += (int)offset else Ignore Next Instruction |
| BLTZL | Branch on Less Than Zero Likely ⁽¹⁾ | if Rs[31] PC += (int)offset else Ignore Next Instruction |
| BNE | Branch on Not Equal | if Rs != Rt PC += (int)offset |
| BNEL | Branch on Not Equal Likely ⁽¹⁾ | if Rs != Rt PC += (int)offset else Ignore Next Instruction |
| BREAK | Breakpoint | Break Exception |
| CLO | Count Leading Ones | Rd = NumLeadingOnes (Rs) |
| CLZ | Count Leading Zeroes | Rd = NumLeadingZeroes (Rs) |
| DERET | Return from Debug Exception | PC = DEPC Exit Debug Mode |
| DI | Atomically Disable Interrupts | Rt = Status; Status _{IE} = 0 |
| DIV | Divide | LO = (int)Rs / (int)Rt HI = (int)Rs % (int)Rt |
| DIVU | Unsigned Divide | LO = (uns)Rs / (uns)Rt HI = (uns)Rs % (uns)Rt |
| EHB | Execution Hazard Barrier | Stop instruction execution until execution hazards are cleared |
| EI | Atomically Enable Interrupts | Rt = Status; Status _{IE} = 1 |
| ERET | Return from Exception | if Status _{ERL} PC = ErrorEPC else PC = EPC Status _{EXL} = 0 Status _{ERL} = 0 LL = 0 |
| EXT | Extract Bit Field | Rt = ExtractField(Rs, pos, size) |
| INS | Insert Bit Field | Rt = InsertField(Rs, Rt, pos, size) |
| J | Unconditional Jump | PC = PC[31:28] offset<<2 |

Note 1: This instruction is deprecated and should not be used.

TABLE 27-1: MIPS32® INSTRUCTION SET (CONTINUED)

| Instruction | Description | Function |
|-------------|--|--|
| JAL | Jump and Link | GPR[31] = PC + 8 PC = PC[31:28] offset<<2 |
| JALR | Jump and Link Register | Rd = PC + 8 PC = Rs |
| JALR.HB | Jump and Link Register with Hazard Barrier | Like JALR, but also clears execution and instruction hazards |
| JR | Jump Register | PC = Rs |
| JR.HB | Jump Register with Hazard Barrier | Like JR, but also clears execution and instruction hazards |
| LB | Load Byte | Rt = (byte)Mem[Rs+offset] |
| LBU | Unsigned Load Byte | Rt = (ubyte)Mem[Rs+offset] |
| LH | Load Halfword | Rt = (half)Mem[Rs+offset] |
| LHU | Unsigned Load Halfword | Rt = (uhalf)Mem[Rs+offset] |
| LL | Load Linked Word | Rt = Mem[Rs+offset] LL _{bit} = 1 LLAdr = Rs + offset |
| LUI | Load Upper Immediate | Rt = immediate << 16 |
| LW | Load Word | Rt = Mem[Rs+offset] |
| LWPC | Load Word, PC relative | Rt = Mem[PC+offset] |
| LWL | Load Word Left | Re = Re MERGE Mem[Rs+offset] |
| LWR | Load Word Right | Re = Re MERGE Mem[Rs+offset] |
| MADD | Multiply-Add | HI LO += (int)Rs * (int)Rt |
| MADDU | Multiply-Add Unsigned | HI LO += (uns)Rs * (uns)Rt |
| MFC0 | Move from Coprocessor 0 | Rt = CPR[0, Rd, sel] |
| MFHI | Move from HI | Rd = HI |
| MFLO | Move from LO | Rd = LO |
| MOVN | Move Conditional on Not Zero | if Rt ≠ 0 then Rd = Rs |
| MOVZ | Move Conditional on Zero | if Rt = 0 then Rd = Rs |
| MSUB | Multiply-Subtract | HI LO -= (int)Rs * (int)Rt |
| MSUBU | Multiply-Subtract Unsigned | HI LO -= (uns)Rs * (uns)Rt |
| MTC0 | Move to Coprocessor 0 | CPR[0, n, Sel] = Rt |
| MTHI | Move to HI | HI = Rs |
| MTLO | Move to LO | LO = Rs |
| MUL | Multiply with register write | HI LO = Unpredictable Rd = ((int)Rs * (int)Rt) _{31..0} |
| MULT | Integer Multiply | HI LO = (int)Rs * (int)Rd |
| MULTU | Unsigned Multiply | HI LO = (uns)Rs * (uns)Rd |
| NOP | No Operation (Assembler idiom for: SLL r0, r0, r0) | |
| NOR | Logical NOR | Rd = ~(Rs Rt) |
| OR | Logical OR | Rd = Rs Rt |
| ORI | Logical OR Immediate | Rt = Rs Immed |
| RDHWR | Read Hardware Register (if enabled by HWRE _{na} Register) | Re = HWR[Rd] |

Note 1: This instruction is deprecated and should not be used.

PIC32MX3XX/4XX

TABLE 27-1: MIPS32® INSTRUCTION SET (CONTINUED)

| Instruction | Description | Function |
|-------------|-------------------------------------|--|
| RDPGPR | Read GPR from Previous Shadow Set | $Rt = SGPR[SRSCtl_{PSS}, Rd]$ |
| ROTR | Rotate Word Right | $Rd = Rt_{sa-1..0} \parallel Rt_{31..sa}$ |
| ROTRV | Rotate Word Right Variable | $Rd = Rt_{Rs-1..0} \parallel Rt_{31..Rs}$ |
| SB | Store Byte | $(byte)Mem[Rs+offset] = Rt$ |
| SC | Store Conditional Word | if $LL_{bit} = 1$ $mem[Rs+offset] = Rt$ $Rt = LL_{bit}$ |
| SDBBP | Software Debug Break Point | Trap to SW Debug Handler |
| SEB | Sign-Extend Byte | $Rd = SignExtend(Rs-7..0)$ |
| SEH | Sign-Extend Half | $Rd = SignExtend(Rs-15..0)$ |
| SH | Store Half | $(half)Mem[Rs+offset] = Rt$ |
| SLL | Shift Left Logical | $Rd = Rt \ll sa$ |
| SLLV | Shift Left Logical Variable | $Rd = Rt \ll Rs[4:0]$ |
| SLT | Set on Less Than | if $(int)Rs < (int)Rt$ $Rd = 1$ else $Rd = 0$ |
| SLTI | Set on Less Than Immediate | if $(int)Rs < (int)Immed$ $Rt = 1$ else $Rt = 0$ |
| SLTIU | Set on Less Than Immediate Unsigned | if $(uns)Rs < (uns)Immed$ $Rt = 1$ else $Rt = 0$ |
| SLTU | Set on Less Than Unsigned | if $(uns)Rs < (uns)Immed$ $Rd = 1$ else $Rd = 0$ |
| SRA | Shift Right Arithmetic | $Rd = (int)Rt \gg sa$ |
| SRAV | Shift Right Arithmetic Variable | $Rd = (int)Rt \gg Rs[4:0]$ |
| SRL | Shift Right Logical | $Rd = (uns)Rt \gg sa$ |
| SRLV | Shift Right Logical Variable | $Rd = (uns)Rt \gg Rs[4:0]$ |
| SSNOP | Superscalar Inhibit No Operation | NOP |
| SUB | Integer Subtract | $Rt = (int)Rs - (int)Rd$ |
| SUBU | Unsigned Subtract | $Rt = (uns)Rs - (uns)Rd$ |
| SW | Store Word | $Mem[Rs+offset] = Rt$ |
| SWL | Store Word Left | $Mem[Rs+offset] = Rt$ |
| SWR | Store Word Right | $Mem[Rs+offset] = Rt$ |
| SYNC | Synchronize | Orders the cached coherent and uncached loads and stores for access to the shared memory |
| SYSCALL | System Call | SystemCallException |
| TEQ | Trap if Equal | if $Rs == Rt$ TrapException |
| TEQI | Trap if Equal Immediate | if $Rs == (int)Immed$ TrapException |

Note 1: This instruction is deprecated and should not be used.

TABLE 27-1: MIPS32® INSTRUCTION SET (CONTINUED)

| Instruction | Description | Function |
|-------------|--|---|
| TGE | Trap if Greater Than or Equal | if (int)Rs >= (int)Rt TrapException |
| TGEI | Trap if Greater Than or Equal Immediate | if (int)Rs >= (int)Immed TrapException |
| TGEIU | Trap if Greater Than or Equal Immediate Unsigned | if (uns)Rs >= (uns)Immed TrapException |
| TGEU | Trap if Greater Than or Equal Unsigned | if (uns)Rs >= (uns)Rt TrapException |
| TLT | Trap if Less Than | if (int)Rs < (int)Rt TrapException |
| TLTI | Trap if Less Than Immediate | if (int)Rs < (int)Immed TrapException |
| TLTIU | Trap if Less Than Immediate Unsigned | if (uns)Rs < (uns)Immed TrapException |
| TLTU | Trap if Less Than Unsigned | if (uns)Rs < (uns)Rt TrapException |
| TNE | Trap if Not Equal | if Rs != Rt TrapException |
| TNEI | Trap if Not Equal Immediate | if Rs != (int)Immed TrapException |
| WAIT | Wait for Interrupt | Go to a low power mode and stall until interrupt occurs |
| WRPGPR | Write to GPR in Previous Shadow Set | SGPR[SRSCtl _{PSS} , Rd] = Rt |
| WSBH | Word Swap Bytes Within Halfwords | Rd = Rt _{23..16} Rt _{31..24} Rt _{7..0} Rt _{15..8} |
| XOR | Exclusive OR | Rd = Rs ^ Rt |
| XORI | Exclusive OR Immediate | Rt = Rs ^ (uns)Immed |

Note 1: This instruction is deprecated and should not be used.

PIC32MX3XX/4XX

NOTES:

28.0 DEVELOPMENT SUPPORT

The PIC® microcontrollers and dsPIC® digital signal controllers are supported with a full range of software and hardware development tools:

- Integrated Development Environment
 - MPLAB® IDE Software
- Compilers/Assemblers/Linkers
 - MPLAB C Compiler for Various Device Families
 - HI-TECH C for Various Device Families
 - MPASM™ Assembler
 - MPLINK™ Object Linker/
MPLIB™ Object Librarian
 - MPLAB Assembler/Linker/Librarian for Various Device Families
- Simulators
 - MPLAB SIM Software Simulator
- Emulators
 - MPLAB REAL ICE™ In-Circuit Emulator
- In-Circuit Debuggers
 - MPLAB ICD 3
 - PICKit™ 3 Debug Express
- Device Programmers
 - PICKit™ 2 Programmer
 - MPLAB PM3 Device Programmer
- Low-Cost Demonstration/Development Boards, Evaluation Kits, and Starter Kits

28.1 MPLAB Integrated Development Environment Software

The MPLAB IDE software brings an ease of software development previously unseen in the 8/16/32-bit microcontroller market. The MPLAB IDE is a Windows® operating system-based application that contains:

- A single graphical interface to all debugging tools
 - Simulator
 - Programmer (sold separately)
 - In-Circuit Emulator (sold separately)
 - In-Circuit Debugger (sold separately)
- A full-featured editor with color-coded context
- A multiple project manager
- Customizable data windows with direct edit of contents
- High-level source code debugging
- Mouse over variable inspection
- Drag and drop variables from source to watch windows
- Extensive on-line help
- Integration of select third party tools, such as IAR C Compilers

The MPLAB IDE allows you to:

- Edit your source files (either C or assembly)
- One-touch compile or assemble, and download to emulator and simulator tools (automatically updates all project information)
- Debug using:
 - Source files (C or assembly)
 - Mixed C and assembly
 - Machine code

MPLAB IDE supports multiple debugging tools in a single development paradigm, from the cost-effective simulators, through low-cost in-circuit debuggers, to full-featured emulators. This eliminates the learning curve when upgrading to tools with increased flexibility and power.

PIC32MX3XX/4XX

28.2 MPLAB C Compilers for Various Device Families

The MPLAB C Compiler code development systems are complete ANSI C compilers for Microchip's PIC18, PIC24 and PIC32 families of microcontrollers and the dsPIC30 and dsPIC33 families of digital signal controllers. These compilers provide powerful integration capabilities, superior code optimization and ease of use.

For easy source level debugging, the compilers provide symbol information that is optimized to the MPLAB IDE debugger.

28.3 HI-TECH C for Various Device Families

The HI-TECH C Compiler code development systems are complete ANSI C compilers for Microchip's PIC family of microcontrollers and the dsPIC family of digital signal controllers. These compilers provide powerful integration capabilities, omniscient code generation and ease of use.

For easy source level debugging, the compilers provide symbol information that is optimized to the MPLAB IDE debugger.

The compilers include a macro assembler, linker, pre-processor, and one-step driver, and can run on multiple platforms.

28.4 MPASM Assembler

The MPASM Assembler is a full-featured, universal macro assembler for PIC10/12/16/18 MCUs.

The MPASM Assembler generates relocatable object files for the MPLINK Object Linker, Intel® standard HEX files, MAP files to detail memory usage and symbol reference, absolute LST files that contain source lines and generated machine code and COFF files for debugging.

The MPASM Assembler features include:

- Integration into MPLAB IDE projects
- User-defined macros to streamline assembly code
- Conditional assembly for multi-purpose source files
- Directives that allow complete control over the assembly process

28.5 MPLINK Object Linker/ MPLIB Object Librarian

The MPLINK Object Linker combines relocatable objects created by the MPASM Assembler and the MPLAB C18 C Compiler. It can link relocatable objects from precompiled libraries, using directives from a linker script.

The MPLIB Object Librarian manages the creation and modification of library files of precompiled code. When a routine from a library is called from a source file, only the modules that contain that routine will be linked in with the application. This allows large libraries to be used efficiently in many different applications.

The object linker/library features include:

- Efficient linking of single libraries instead of many smaller files
- Enhanced code maintainability by grouping related modules together
- Flexible creation of libraries with easy module listing, replacement, deletion and extraction

28.6 MPLAB Assembler, Linker and Librarian for Various Device Families

MPLAB Assembler produces relocatable machine code from symbolic assembly language for PIC24, PIC32 and dsPIC devices. MPLAB C Compiler uses the assembler to produce its object file. The assembler generates relocatable object files that can then be archived or linked with other relocatable object files and archives to create an executable file. Notable features of the assembler include:

- Support for the entire device instruction set
- Support for fixed-point and floating-point data
- Command line interface
- Rich directive set
- Flexible macro language
- MPLAB IDE compatibility

28.7 MPLAB SIM Software Simulator

The MPLAB SIM Software Simulator allows code development in a PC-hosted environment by simulating the PIC MCUs and dsPIC® DSCs on an instruction level. On any given instruction, the data areas can be examined or modified and stimuli can be applied from a comprehensive stimulus controller. Registers can be logged to files for further run-time analysis. The trace buffer and logic analyzer display extend the power of the simulator to record and track program execution, actions on I/O, most peripherals and internal registers.

The MPLAB SIM Software Simulator fully supports symbolic debugging using the MPLAB C Compilers, and the MPASM and MPLAB Assemblers. The software simulator offers the flexibility to develop and debug code outside of the hardware laboratory environment, making it an excellent, economical software development tool.

28.8 MPLAB REAL ICE In-Circuit Emulator System

MPLAB REAL ICE In-Circuit Emulator System is Microchip's next generation high-speed emulator for Microchip Flash DSC and MCU devices. It debugs and programs PIC® Flash MCUs and dsPIC® Flash DSCs with the easy-to-use, powerful graphical user interface of the MPLAB Integrated Development Environment (IDE), included with each kit.

The emulator is connected to the design engineer's PC using a high-speed USB 2.0 interface and is connected to the target with either a connector compatible with in-circuit debugger systems (RJ11) or with the new high-speed, noise tolerant, Low-Voltage Differential Signal (LVDS) interconnection (CAT5).

The emulator is field upgradable through future firmware downloads in MPLAB IDE. In upcoming releases of MPLAB IDE, new devices will be supported, and new features will be added. MPLAB REAL ICE offers significant advantages over competitive emulators including low-cost, full-speed emulation, run-time variable watches, trace analysis, complex breakpoints, a ruggedized probe interface and long (up to three meters) interconnection cables.

28.9 MPLAB ICD 3 In-Circuit Debugger System

MPLAB ICD 3 In-Circuit Debugger System is Microchip's most cost effective high-speed hardware debugger/programmer for Microchip Flash Digital Signal Controller (DSC) and microcontroller (MCU) devices. It debugs and programs PIC® Flash microcontrollers and dsPIC® DSCs with the powerful, yet easy-to-use graphical user interface of MPLAB Integrated Development Environment (IDE).

The MPLAB ICD 3 In-Circuit Debugger probe is connected to the design engineer's PC using a high-speed USB 2.0 interface and is connected to the target with a connector compatible with the MPLAB ICD 2 or MPLAB REAL ICE systems (RJ-11). MPLAB ICD 3 supports all MPLAB ICD 2 headers.

28.10 PICkit 3 In-Circuit Debugger/Programmer and PICkit 3 Debug Express

The MPLAB PICkit 3 allows debugging and programming of PIC® and dsPIC® Flash microcontrollers at a most affordable price point using the powerful graphical user interface of the MPLAB Integrated Development Environment (IDE). The MPLAB PICkit 3 is connected to the design engineer's PC using a full speed USB interface and can be connected to the target via an Microchip debug (RJ-11) connector (compatible with MPLAB ICD 3 and MPLAB REAL ICE). The connector uses two device I/O pins and the reset line to implement in-circuit debugging and In-Circuit Serial Programming™.

The PICkit 3 Debug Express include the PICkit 3, demo board and microcontroller, hookup cables and CDROM with user's guide, lessons, tutorial, compiler and MPLAB IDE software.

PIC32MX3XX/4XX

28.11 PICkit 2 Development Programmer/Debugger and PICkit 2 Debug Express

The PICkit™ 2 Development Programmer/Debugger is a low-cost development tool with an easy to use interface for programming and debugging Microchip's Flash families of microcontrollers. The full featured Windows® programming interface supports baseline (PIC10F, PIC12F5xx, PIC16F5xx), midrange (PIC12F6xx, PIC16F), PIC18F, PIC24, dsPIC30, dsPIC33, and PIC32 families of 8-bit, 16-bit, and 32-bit microcontrollers, and many Microchip Serial EEPROM products. With Microchip's powerful MPLAB Integrated Development Environment (IDE) the PICkit™ 2 enables in-circuit debugging on most PIC® microcontrollers. In-Circuit-Debugging runs, halts and single steps the program while the PIC microcontroller is embedded in the application. When halted at a breakpoint, the file registers can be examined and modified.

The PICkit 2 Debug Express include the PICkit 2, demo board and microcontroller, hookup cables and CDROM with user's guide, lessons, tutorial, compiler and MPLAB IDE software.

28.12 MPLAB PM3 Device Programmer

The MPLAB PM3 Device Programmer is a universal, CE compliant device programmer with programmable voltage verification at VDDMIN and VDDMAX for maximum reliability. It features a large LCD display (128 x 64) for menus and error messages and a modular, detachable socket assembly to support various package types. The ICSP™ cable assembly is included as a standard item. In Stand-Alone mode, the MPLAB PM3 Device Programmer can read, verify and program PIC devices without a PC connection. It can also set code protection in this mode. The MPLAB PM3 connects to the host PC via an RS-232 or USB cable. The MPLAB PM3 has high-speed communications and optimized algorithms for quick programming of large memory devices and incorporates an MMC card for file storage and data applications.

28.13 Demonstration/Development Boards, Evaluation Kits, and Starter Kits

A wide variety of demonstration, development and evaluation boards for various PIC MCUs and dsPIC DSCs allows quick application development on fully functional systems. Most boards include prototyping areas for adding custom circuitry and provide application firmware and source code for examination and modification.

The boards support a variety of features, including LEDs, temperature sensors, switches, speakers, RS-232 interfaces, LCD displays, potentiometers and additional EEPROM memory.

The demonstration and development boards can be used in teaching environments, for prototyping custom circuits and for learning about various microcontroller applications.

In addition to the PICDEM™ and dsPICDEM™ demonstration/development board series of circuits, Microchip has a line of evaluation kits and demonstration software for analog filter design, KEELOQ® security ICs, CAN, IrDA®, PowerSmart battery management, SEEVAL® evaluation system, Sigma-Delta ADC, flow rate sensing, plus many more.

Also available are starter kits that contain everything needed to experience the specified device. This usually includes a single application and debug capability, all on one board.

Check the Microchip web page (www.microchip.com) for the complete list of demonstration, development and evaluation kits.

29.0 ELECTRICAL CHARACTERISTICS

This section provides an overview of PIC32MX3XX/4XX electrical characteristics. Additional information will be provided in future revisions of this document as it becomes available.

Absolute maximum ratings for the PIC32MX3XX/4XX are listed below. Exposure to these maximum rating conditions for extended periods may affect device reliability. Functional operation of the device at these or any other conditions above the parameters indicated in the operation listings of this specification is not implied.

Absolute Maximum Ratings

(Note 1)

| | |
|---|-----------------------|
| Ambient temperature under bias..... | -40°C to +105°C |
| Storage temperature | -65°C to +150°C |
| Voltage on VDD with respect to VSS | -0.3V to +4.0V |
| Voltage on any pin that is not 5V tolerant, with respect to VSS (Note 3)..... | -0.3V to (VDD + 0.3V) |
| Voltage on any 5V tolerant pin with respect to VSS when VDD ≥ 2.3V (Note 3)..... | -0.3V to +5.5V |
| Voltage on any 5V tolerant pin with respect to VSS when VDD < 2.3V (Note 3)..... | -0.3V to +3.6V |
| Voltage on VCORE with respect to VSS | -0.3V to 2.0V |
| Voltage on VBUS with respect to VSS | -0.3V to +5.5V |
| Maximum current out of VSS pin(s)..... | 300 mA |
| Maximum current into VDD pin(s) (Note 2)..... | 300 mA |
| Maximum output current sunk by any I/O pin..... | 25 mA |
| Maximum output current sourced by any I/O pin | 25 mA |
| Maximum current sunk by all ports | 200 mA |
| Maximum current sourced by all ports (Note 2)..... | 200 mA |

Note 1: Stresses above those listed under “**Absolute Maximum Ratings**” may cause permanent damage to the device. This is a stress rating only and functional operation of the device at those or any other conditions above those indicated in the operation listings of this specification is not implied. Exposure to maximum rating conditions for extended periods may affect device reliability.

2: Maximum allowable current is a function of device maximum power dissipation (see [Table 29-2](#)).

3: See the “[Pin Diagrams](#)” section for the 5V tolerant pins.

PIC32MX3XX/4XX

29.1 DC Characteristics

TABLE 29-1: OPERATING MIPS VS. VOLTAGE

| Characteristic | VDD Range (in Volts) | Temp. Range (in °C) | Max. Frequency |
|----------------|-------------------------|------------------------|-----------------|
| | | | PIC32MX3XX/4XX |
| DC5 | 2.3V-3.6V | -40°C to +85°C | 80 MHz (Note 1) |
| DC5b | 2.3V-3.6V | -40°C to +105°C | 80 MHz (Note 1) |

Note 1: 40 MHz maximum for PIC32MX320F032H and PIC32MX420F032H devices.

TABLE 29-2: THERMAL OPERATING CONDITIONS

| Rating | Symbol | Min. | Typical | Max. | Unit |
|---|--------|---------------|---------|------|------|
| Industrial Temperature Devices | | | | | |
| Operating Junction Temperature Range | TJ | -40 | — | +125 | °C |
| Operating Ambient Temperature Range | TA | -40 | — | +85 | °C |
| V-Temp Temperature Devices | | | | | |
| Operating Junction Temperature Range | TJ | -40 | — | +140 | °C |
| Operating Ambient Temperature Range | TA | -40 | — | +105 | °C |
| Power Dissipation: Internal Chip Power Dissipation: PINT = VDD x (IDD – S IOH) I/O Pin Power Dissipation: I/O = S ({VDD – VOH} x IOH) + S (VOL x IOL) | PD | PINT + PI/O | | | W |
| Maximum Allowed Power Dissipation | PDMAX | (TJ – TA)/θJA | | | W |

TABLE 29-3: THERMAL PACKAGING CHARACTERISTICS

| Characteristics | Symbol | Typical | Max. | Unit | Notes |
|---|--------|---------|------|------|-------|
| Package Thermal Resistance, 121-Pin XBGA (10x10x1.1 mm) | θJA | 40 | — | °C/W | 1 |
| Package Thermal Resistance, 100-Pin TQFP (12x12x1 mm) | θJA | 43 | — | °C/W | 1 |
| Package Thermal Resistance, 64-Pin TQFP (10x10x1 mm) | θJA | 47 | — | °C/W | 1 |
| Package Thermal Resistance, 64-Pin QFN (9x9x0.9 mm) | θJA | 28 | — | °C/W | 1 |

Note 1: Junction to ambient thermal resistance, Theta-JA (θJA) numbers are achieved by package simulations.

TABLE 29-4: DC TEMPERATURE AND VOLTAGE SPECIFICATIONS

| DC CHARACTERISTICS | | Standard Operating Conditions: 2.3V to 3.6V (unless otherwise stated) Operating temperature -40°C ≤TA ≤+85°C for Industrial -40°C ≤TA ≤+105°C for V-Temp | | | | | |
|--------------------------|--------|---|------|---------|------|-------|------------|
| Param. No. | Symbol | Characteristics | Min. | Typical | Max. | Units | Conditions |
| Operating Voltage | | | | | | | |
| DC10 | VDD | Supply Voltage | 2.3 | — | 3.6 | V | — |
| DC12 | VDR | RAM Data Retention Voltage (Note 1) | 1.75 | — | — | V | — |
| DC16 | VPOR | VDD Start Voltage to Ensure Internal Power-on Reset Signal | 1.75 | — | 1.95 | V | — |
| DC17 | SVDD | VDD Rise Rate to Ensure Internal Power-on Reset Signal | 0.05 | — | — | V/ms | — |

Note 1: This is the limit to which VDD can be lowered without losing RAM data.

TABLE 29-5: DC CHARACTERISTICS: OPERATING CURRENT (IDD)

| DC CHARACTERISTICS | | | Standard Operating Conditions: 2.3V to 3.6V (unless otherwise stated) Operating temperature -40°C ≤TA ≤+85°C for Industrial -40°C ≤TA ≤+105°C for V-Temp | | | | |
|--|------------------------|------|---|---------------------------|---------------------------|------|----------------------------------|
| Param. No. | Typical ⁽³⁾ | Max. | Units | Conditions | | | |
| Operating Current (IDD)^(1,2) | | | | | | | |
| DC20 | 8.5 | 13 | mA | Code executing from Flash | -40°C, +25°C, +85°C | — | 4 MHz |
| | 9 | 15 | | | +105°C | | |
| DC20c | 4.0 | — | mA | Code executing from SRAM | — | — | — |
| DC21 | 23.5 | 32 | mA | Code executing from Flash | — | — | 20 MHz (Note 4) |
| DC21c | 16.4 | — | mA | Code executing from SRAM | | | |
| DC22 | 48 | 61 | mA | Code executing from Flash | — | — | 60 MHz (Note 4) |
| DC22c | 45 | — | mA | Code executing from SRAM | | | |
| DC23 | 55 | 75 | mA | Code executing from Flash | -40°C, +25°C, +85°C | 2.3V | 80 MHz |
| | 60 | 100 | | | +105°C | | |
| DC23c | 55 | — | mA | Code executing from SRAM | — | — | — |
| DC24 | — | 100 | μA | — | -40°C | 2.3V | LPRC (31 kHz) (Note 4) |
| DC24a | — | 130 | μA | — | +25°C | | |
| DC24b | — | 670 | μA | — | +85°C | | |
| DC24c | — | 850 | μA | — | +105°C | | |
| DC25 | 94 | — | μA | — | -40°C | 3.3V | |
| DC25a | 125 | — | μA | — | +25°C | | |
| DC25b | 302 | — | μA | — | +85°C | | |
| DC25d | 400 | — | μA | — | +105°C | | |
| DC25c | 71 | — | μA | Code executing from SRAM | — | — | |
| DC26 | — | 110 | μA | — | -40°C | 3.6V | |
| DC26a | — | 180 | μA | — | +25°C | | |
| DC26b | — | 700 | μA | — | +85°C | | |
| DC26c | — | 900 | μA | — | +105°C | | |

Note 1: A device's IDD supply current is mainly a function of the operating voltage and frequency. Other factors, such as PBCLK (Peripheral Bus Clock) frequency, number of peripheral modules enabled, internal code execution pattern, execution from program Flash memory vs. SRAM, I/O pin loading and switching rate, oscillator type as well as temperature can have an impact on the current consumption.

2: The test conditions for IDD measurements are as follows: Oscillator mode = EC+PLL with OSC1 driven by external square wave from rail to rail and PBCLK divisor = 1:8. CPU, Program Flash and SRAM data memory are operational, Program Flash memory Wait states = 7, program cache and prefetch are disabled and SRAM data memory Wait states = 1. All peripheral modules are disabled (ON bit = 0). WDT and FSCM are disabled. All I/O pins are configured as inputs and pulled to VSS. MCLR = VDD.

3: Data in "Typical" column is at 3.3V, 25°C at specified operating frequency unless otherwise stated. Parameters are for design guidance only and are not tested.

4: This parameter is characterized, but not tested in manufacturing.

PIC32MX3XX/4XX

TABLE 29-6: DC CHARACTERISTICS: IDLE CURRENT (IDLE)

| DC CHARACTERISTICS | | | Standard Operating Conditions: 2.3V to 3.6V (unless otherwise stated) Operating temperature -40°C ≤TA ≤+85°C for Industrial -40°C ≤TA ≤+105°C for V-Temp | | |
|--|------------------------|------|---|---------------------|------|
| Parameter No. | Typical ⁽²⁾ | Max. | Units | Conditions | |
| Idle Current (IDLE): Core OFF, Clock ON Base Current (Note 1) | | | | | |
| DC30 | — | 5 | mA | -40°C, +25°C, +85°C | 2.3V |
| DC30a | 1.4 | — | mA | -40°C, +25°C, +85°C | — |
| DC30b | — | 5 | mA | -40°C, +25°C, +85°C | 3.6V |
| DC30c | — | 8 | mA | +105°C | |
| DC31 | — | 15 | mA | -40°C, +25°C, +85°C | 2.3V |
| DC31a | 13 | — | mA | -40°C, +25°C, +85°C | — |
| DC31b | — | 17 | mA | -40°C, +25°C, +85°C | 3.6V |
| DC31c | — | 25 | mA | +105°C | |
| DC32 | — | 22 | mA | -40°C, +25°C, +85°C | 2.3V |
| DC32a | 20 | — | mA | -40°C, +25°C, +85°C | — |
| DC32b | — | 25 | mA | -40°C, +25°C, +85°C | 3.6V |
| DC32c | — | 32 | mA | +105°C | |
| DC33 | — | 29 | mA | -40°C, +25°C, +85°C | 2.3V |
| DC33a | 24 | — | mA | -40°C, +25°C, +85°C | — |
| DC33b | — | 32 | mA | -40°C, +25°C, +85°C | 3.6V |
| DC33c | — | 40 | mA | +105°C | |
| DC34 | — | 36 | μA | -40°C | 2.3V |
| DC34a | — | 62 | μA | +25°C | |
| DC34b | — | 392 | μA | +85°C | |
| DC34c | — | 550 | μA | +105°C | |
| DC35 | 35 | — | μA | -40°C | 3.3V |
| DC35a | 65 | — | μA | +25°C | |
| DC35b | 242 | — | μA | +85°C | |
| DC35c | 350 | — | μA | +105°C | |
| DC36 | — | 43 | μA | -40°C | 3.6V |
| DC36a | — | 106 | μA | +25°C | |
| DC36b | — | 414 | μA | +85°C | |
| DC36c | — | 600 | μA | +105°C | |

Note 1: The test conditions for base IDLE current measurements are as follows: System clock is enabled and PBCLK divisor = 1:8. CPU in Idle mode (CPU core halted). Only digital peripheral modules are enabled (ON bit = 1) and being clocked. WDT and FSCM are disabled. All I/O pins are configured as inputs and pulled to Vss. MCLR = VDD.

2: Data in “Typical” column is at 3.3V, 25°C unless otherwise stated. Parameters are for design guidance only and are not tested.

3: This parameter is characterized, but not tested in manufacturing.

TABLE 29-7: DC CHARACTERISTICS: POWER-DOWN CURRENT (IPD)

| DC CHARACTERISTICS | | | Standard Operating Conditions: 2.3V to 3.6V (unless otherwise stated) Operating temperature -40°C ≤TA ≤+85°C for Industrial -40°C ≤TA ≤+105°C for V-Temp | | |
|---|------------------------|--------------------|--|------------|--|
| Parameter No. | Typical ⁽²⁾ | Max. | Units | Conditions | |
| Power-Down Current (IPD)⁽¹⁾ | | | | | |
| DC40 | 7 | 30 | μA | -40°C | 2.3V Base Power-Down Current (Note 6) |
| DC40a | 24 | 30 | μA | +25°C | |
| DC40b | 205 | 300 | μA | +85°C | |
| DC40h | 450 | 900 | μA | +105°C | |
| DC40c | 25 | — | μA | +25°C | 3.3V Base Power-Down Current |
| DC40d | 9 | 70 | μA | -40°C | 3.6V Base Power-Down Current |
| DC40e | 25 | 70 | μA | +25°C | |
| DC40g | 115 | 200 ⁽⁵⁾ | μA | +70°C | |
| DC40f | 200 | 400 | μA | +85°C | |
| DC40i | 470 | 1200 | μA | +105°C | |
| Module Differential Current | | | | | |
| DC41 | — | 10 | μA | -40°C | 2.3V Watchdog Timer Current: ΔIWDT (Notes 3, 6) |
| DC41a | — | 10 | μA | +25°C | |
| DC41b | — | 10 | μA | +85°C | |
| DC41g | — | 12 | μA | +105°C | |
| DC41c | 5 | — | μA | +25°C | 3.3V Watchdog Timer Current: ΔIWDT (Note 3) |
| DC41d | — | 10 | μA | -40°C | 3.6V Watchdog Timer Current: ΔIWDT (Note 3) |
| DC41e | — | 10 | μA | +25°C | |
| DC41f | — | 12 | μA | +85°C | |
| DC41h | — | 15 | μA | +105°C | |
| DC42 | — | 10 | μA | -40°C | 2.3V RTCC + Timer1 w/32 kHz Crystal: ΔIRTCC (Notes 3, 6) |
| DC42a | — | 17 | μA | +25°C | |
| DC42b | — | 37 | μA | +85°C | |
| DC42h | — | 45 | μA | +105°C | |
| DC42c | 23 | — | μA | +25°C | 3.3V RTCC + Timer1 w/32 kHz Crystal: ΔIRTCC (Note 3) |
| DC42e | — | 10 | μA | -40°C | 3.6V RTCC + Timer1 w/32 kHz Crystal: ΔIRTCC (Note 3) |
| DC42f | — | 30 | μA | +25°C | |
| DC42g | — | 44 | μA | +85°C | |
| DC42i | — | 44 | μA | +105°C | |

- Note 1:** Base IPD is measured with all digital peripheral modules disabled. All I/Os are configured as inputs and pulled low. WDT and FSCM are disabled.
- 2:** Data in the “Typical” column is at 3.3V, 25°C unless otherwise stated. Parameters are for design guidance only and are not tested.
- 3:** The Δ current is the additional current consumed when the module is enabled. This current should be added to the base IPD current.
- 4:** Test conditions for ADC module differential current are as follows: Internal ADC RC oscillator enabled.
- 5:** Data is characterized at +70°C and not tested. Parameter is for design guidance only.
- 6:** This parameter is characterized, but not tested in manufacturing.

PIC32MX3XX/4XX

TABLE 29-7: DC CHARACTERISTICS: POWER-DOWN CURRENT (IPD) (CONTINUED)

| DC CHARACTERISTICS | | | Standard Operating Conditions: 2.3V to 3.6V (unless otherwise stated) Operating temperature -40°C ≤TA ≤+85°C for Industrial -40°C ≤TA ≤+105°C for V-Temp | | | |
|--|------------------------|------|--|------------|------|--|
| Parameter No. | Typical ⁽²⁾ | Max. | Units | Conditions | | |
| Module Differential Current (Continued) | | | | | | |
| DC43 | — | 1100 | μA | -40°C | 2.5V | ADC: ΔI _{ADC} (Notes 3, 4, 6) |
| DC43a | — | 1100 | μA | +25°C | | |
| DC43b | — | 1000 | μA | +85°C | | |
| DC43h | — | 1200 | μA | +105°C | | |
| DC43c | 880 | — | μA | — | — | ADC: ΔI _{ADC} (Notes 3, 4) |
| DC43e | — | 1100 | μA | -40°C | 3.6V | ADC: ΔI _{ADC} (Notes 3, 4) |
| DC43f | — | 1100 | μA | +25°C | | |
| DC43g | — | 1000 | μA | +85°C | | |
| DC43i | — | 1200 | μA | +105°C | | |

- Note 1:** Base IPD is measured with all digital peripheral modules disabled. All I/Os are configured as inputs and pulled low. WDT and FSCM are disabled.
- 2:** Data in the “Typical” column is at 3.3V, 25°C unless otherwise stated. Parameters are for design guidance only and are not tested.
- 3:** The Δ current is the additional current consumed when the module is enabled. This current should be added to the base IPD current.
- 4:** Test conditions for ADC module differential current are as follows: Internal ADC RC oscillator enabled.
- 5:** Data is characterized at +70°C and not tested. Parameter is for design guidance only.
- 6:** This parameter is characterized, but not tested in manufacturing.

TABLE 29-8: DC CHARACTERISTICS: I/O PIN INPUT SPECIFICATIONS

| DC CHARACTERISTICS | | | Standard Operating Conditions: 2.3V to 3.6V (unless otherwise stated) Operating temperature -40°C ≤TA ≤+85°C for Industrial -40°C ≤TA ≤+105°C for V-Temp | | | | |
|--|-----------------|------------------------------------|--|------------------------|---|-------|---|
| Param. No. | Symbol | Characteristics | Min. | Typical ⁽¹⁾ | Max. | Units | Conditions |
| DI10 DI15 DI16 DI17 DI18 DI19 | V _{IL} | Input Low Voltage | | | | | |
| | | I/O pins: with TTL Buffer | V _{SS} | — | 0.15 V _{DD} | V | (Note 4) |
| | | with Schmitt Trigger Buffer | V _{SS} | — | 0.2 V _{DD} | V | (Note 4) |
| | | $\overline{\text{MCLR}}$ | V _{SS} | — | 0.2 V _{DD} | V | (Note 4) |
| | | OSC1 (XT mode) | V _{SS} | — | 0.2 V _{DD} | V | (Note 4) |
| | | OSC1 (HS mode) | V _{SS} | — | 0.2 V _{DD} | V | (Note 4) |
| | | SDAx, SCLx | V _{SS} | — | 0.3 V _{DD} | V | SMBus disabled (Note 4) |
| SDAx, SCLx | V _{SS} | — | 0.8 | V | SMBus enabled (Note 4) | | |
| DI20 DI25 DI26 DI27 DI28 DI29 | V _{IH} | Input High Voltage | | | | | |
| | | I/O pins: with Analog Functions | 0.8 V _{DD} | — | V _{DD} | V | (Note 4) |
| | | Digital Only | 0.8 V _{DD} | — | | V | (Note 4) |
| | | with TTL Buffer | 0.25V _{DD} + 0.8V | — | 5.5 | V | (Note 4) |
| | | with Schmitt Trigger Buffer | 0.8 V _{DD} | — | 5.5 | V | (Note 4) |
| | | $\overline{\text{MCLR}}$ | 0.8 V _{DD} | — | V _{DD} | V | (Note 4) |
| | | OSC1 (XT mode) | 0.7 V _{DD} | — | V _{DD} | V | (Note 4) |
| | | OSC1 (HS mode) | 0.7 V _{DD} | — | V _{DD} | V | (Note 4) |
| | | SDAx, SCLx | 0.7 V _{DD} | — | 5.5 | V | SMBus disabled (Note 4) |
| SDAx, SCLx | 2.1 | — | 5.5 | V | SMBus enabled, 2.3V ≤V _{PIN} ≤5.5 (Note 4) | | |
| DI30 | ICNPU | CNxx Pull up Current | 50 | 250 | 400 | μA | V _{DD} = 3.3V, V _{PIN} = V _{SS} |
| DI50 DI51 DI55 DI56 | I _{IL} | Input Leakage Current | | | | | (Note 3) |
| | | I/O Ports | — | — | ±1 | μA | V _{SS} ≤V _{PIN} ≤V _{DD} , Pin at high-impedance |
| | | Analog Input Pins | — | — | ±1 | μA | V _{SS} ≤V _{PIN} ≤V _{DD} , Pin at high-impedance |
| | | $\overline{\text{MCLR}}$ | — | — | ±1 | μA | V _{SS} ≤V _{PIN} ≤V _{DD} |
| OSC1 | — | — | ±1 | μA | V _{SS} ≤V _{PIN} ≤V _{DD} , XT and HS modes | | |

- Note 1:** Data in "Typical" column is at 3.3V, 25°C unless otherwise stated. Parameters are for design guidance only and are not tested.
- 2:** The leakage current on the $\overline{\text{MCLR}}$ pin is strongly dependent on the applied voltage level. The specified levels represent normal operating conditions. Higher leakage current may be measured at different input voltages.
- 3:** Negative current is defined as current sourced by the pin.
- 4:** This parameter is characterized, but not tested in manufacturing.

PIC32MX3XX/4XX

TABLE 29-9: DC CHARACTERISTICS: I/O PIN OUTPUT SPECIFICATIONS

| DC CHARACTERISTICS | | | Standard Operating Conditions: 2.3V to 3.6V (unless otherwise stated) Operating temperature -40°C ≤TA ≤+85°C for Industrial -40°C ≤TA ≤+105°C for V-Temp | | | | |
|--------------------|--------|---|--|---------|------|-------|--|
| Param. No. | Symbol | Characteristics | Min. | Typical | Max. | Units | Conditions |
| DO10 | VOL | Output Low Voltage I/O Ports | — | — | 0.4 | V | IO _L = 7 mA, V _{DD} = 3.6V |
| | | | — | — | 0.4 | V | IO _L = 6 mA, V _{DD} = 2.3V |
| DO16 | | OSC2/CLKO | — | — | 0.4 | V | IO _L = 3.5 mA, V _{DD} = 3.6V |
| | | | — | — | 0.4 | V | IO _L = 2.5 mA, V _{DD} = 2.3V |
| DO20 | VOH | Output High Voltage I/O Ports | 2.4 | — | — | V | IO _H = -12 mA, V _{DD} = 3.6V |
| | | | 1.4 | — | — | V | IO _H = -12 mA, V _{DD} = 2.3V |
| DO26 | | OSC2/CLKO | 2.4 | — | — | V | IO _H = -12 mA, V _{DD} = 3.6V |
| | | | 1.4 | — | — | V | IO _H = -12 mA, V _{DD} = 2.3V |

TABLE 29-10: ELECTRICAL CHARACTERISTICS: BROWN-OUT RESET (BOR)

| DC CHARACTERISTICS | | | Standard Operating Conditions: 2.3V to 3.6V (unless otherwise stated) Operating temperature -40°C ≤TA ≤+85°C for Industrial -40°C ≤TA ≤+105°C for V-Temp | | | | |
|--------------------|--------|---|--|---------|------|-------|------------|
| Param. No. | Symbol | Characteristics | Min. | Typical | Max. | Units | Conditions |
| BO10 | VBOR | BOR Event on V _{DD} transition high-to-low | 2.0 | — | 2.3 | V | — |

TABLE 29-11: DC CHARACTERISTICS: PROGRAM MEMORY⁽³⁾

| DC CHARACTERISTICS | | | Standard Operating Conditions: 2.3V to 3.6V (unless otherwise stated) Operating temperature -40°C ≤TA ≤+85°C for Industrial -40°C ≤TA ≤+105°C for V-Temp | | | | |
|-----------------------------|------------|--|---|------------------------|------|-------|------------|
| Param. No. | Symbol | Characteristics | Min. | Typical ⁽¹⁾ | Max. | Units | Conditions |
| Program Flash Memory | | | | | | | |
| D130 | EP | Cell Endurance | 1000 | — | — | E/W | — |
| D131 | VPR | VDD for Read | V _{MIN} | — | 3.6 | V | — |
| D132 | VPEW | VDD for Erase or Write | 3.0 | — | 3.6 | V | — |
| D134 | TRETD | Characteristic Retention | 20 | — | — | Year | — |
| D135 | IDDP | Supply Current during Programming | — | 10 | — | mA | — |
| | TWW | Word Write Cycle Time | 20 | — | 40 | μs | — |
| D136 | TRW | Row Write Cycle Time ⁽²⁾ (128 words per row) | 3 | 4.5 | — | ms | — |
| D137 | TPE | Page Erase Cycle Time | 20 | — | — | ms | — |
| | TCE | Chip Erase Cycle Time | 80 | — | — | ms | — |
| D138 | LVDstartup | Flash LVD Delay | — | — | 6 | μs | — |

Note 1: Data in “Typical” column is at 3.3V, 25°C unless otherwise stated.

2: The minimum SYSCLK for row programming is 4 MHz. Care should be taken to minimize bus activities during row programming, such as suspending any memory-to-memory DMA operations. If heavy bus loads are expected, selecting Bus Matrix Arbitration mode 2 (rotating priority) may be necessary. The default Arbitration mode is mode 1 (CPU has lowest priority).

3: Refer to the “PIC32MX Flash Programming Specification” (DS61145) for operating conditions during programming and erase cycles.

TABLE 29-12: PROGRAM FLASH MEMORY WAIT STATE CHARACTERISTICS

| DC CHARACTERISTICS | | Standard Operating Conditions: 2.3V to 3.6V (unless otherwise stated) Operating temperature -40°C ≤TA ≤+85°C for Industrial -40°C ≤TA ≤+105°C for V-Temp | | |
|----------------------------|----------|---|----------|--|
| Required Flash wait states | SYSCLK | Units | Comments | |
| 0 Wait State | 0 to 30 | MHz | — | |
| 1 Wait State | 31 to 60 | | | |
| 2 Wait States | 61 to 80 | | | |

Note 1: 40 MHz maximum for PIC32MX320F032H and PIC32MX420F032H devices.

PIC32MX3XX/4XX

TABLE 29-13: COMPARATOR SPECIFICATIONS

| DC CHARACTERISTICS | | | Standard Operating Conditions: 2.3V to 3.6V (unless otherwise stated) Operating temperature -40°C ≤TA ≤+85°C for Industrial -40°C ≤TA ≤+105°C for V-Temp | | | | |
|--------------------|--------|------------------------------------|---|---------|------|-------|--|
| Param. No. | Symbol | Characteristics | Min. | Typical | Max. | Units | Comments |
| D300 | VIOFF | Input Offset Voltage | — | ±7.5 | ±25 | mV | AVDD = VDD, AVSS = VSS |
| D301 | VICM | Input Common Mode Voltage | 0 | — | VDD | V | AVDD = VDD, AVSS = VSS (Note 2) |
| D302 | CMRR | Common Mode Rejection Ratio | 55 | — | — | dB | Max VICM = (VDD - 1)V (Note 2) |
| D303 | TRESP | Response Time | — | 150 | 400 | ns | AVDD = VDD, AVSS = VSS (Notes 1,2) |
| D304 | ON2OV | Comparator Enabled to Output Valid | — | — | 10 | µs | Comparator module is configured before setting the comparator ON bit. (Note 2) |
| D305 | IVREF | Internal Voltage Reference | 0.57 | 0.6 | 0.63 | V | — |

Note 1: Response time measured with one comparator input at $(VDD - 1.5)/2$, while the other input transitions from VSS to VDD.

2: These parameters are characterized but not tested.

TABLE 29-14: VOLTAGE REFERENCE SPECIFICATIONS

| DC CHARACTERISTICS | | | Standard Operating Conditions: 2.3V to 3.6V (unless otherwise stated) Operating temperature -40°C ≤TA ≤+85°C for Industrial -40°C ≤TA ≤+105°C for V-Temp | | | | |
|--------------------|--------|------------------------------|---|---------|--------|-------|----------|
| Param. No. | Symbol | Characteristics | Min. | Typical | Max. | Units | Comments |
| D310 | VRES | Resolution | VDD/24 | — | VDD/32 | LSb | — |
| D311 | VRAA | Absolute Accuracy | — | — | 1/2 | LSb | — |
| D312 | TSET | Settling Time ⁽¹⁾ | — | — | 10 | µs | — |

Note 1: Settling time measured while CVRR = 1 and CVR3:CVR0 transitions from '0000' to '1111'. This parameter is characterized, but not tested in manufacturing.

TABLE 29-15: INTERNAL VOLTAGE REGULATOR SPECIFICATIONS

| DC CHARACTERISTICS | | | Standard Operating Conditions: 2.3V to 3.6V (unless otherwise stated) Operating temperature -40°C ≤TA ≤+85°C for Industrial -40°C ≤TA ≤+105°C for V-Temp | | | | |
|--------------------|--------|---------------------------------|---|---------|------|-------|---|
| Param. No. | Symbol | Characteristics | Min. | Typical | Max. | Units | Comments |
| D320 | VCORE | Regulator Output Voltage | 1.62 | 1.80 | 1.98 | V | — |
| D321 | CEFC | External Filter Capacitor Value | 8 | 10 | — | µF | Capacitor must be low series resistance (< 1 Ohm) |
| D322 | TPWRT | Power-up Timer Period | — | 64 | — | ms | ENVREG = 0 |

29.2 AC Characteristics and Timing Parameters

The information contained in this section defines PIC32MX3XX/4XX AC characteristics and timing parameters.

FIGURE 29-1: LOAD CONDITIONS FOR DEVICE TIMING SPECIFICATIONS

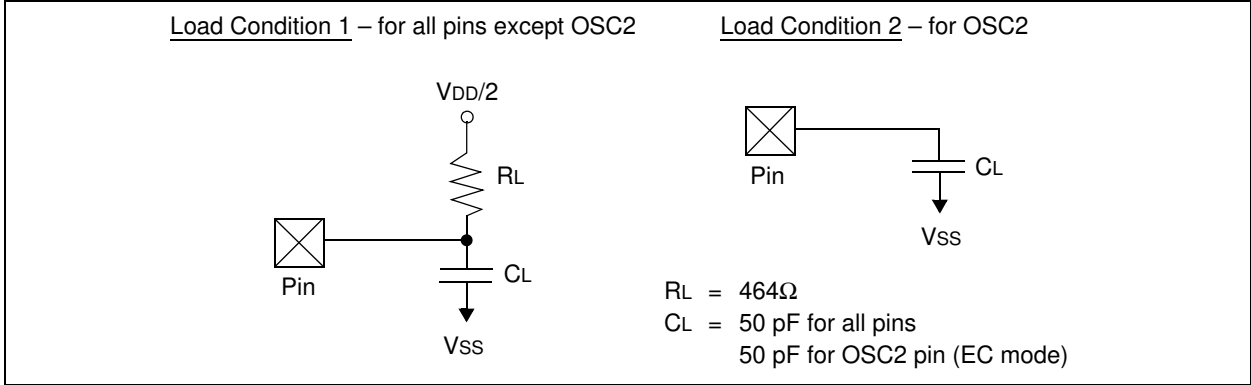
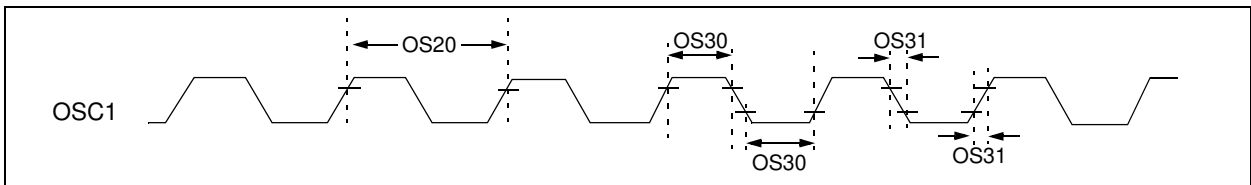

TABLE 29-16: CAPACITIVE LOADING REQUIREMENTS ON OUTPUT PINS

| AC CHARACTERISTICS | | | Standard Operating Conditions: 2.3V to 3.6V (unless otherwise stated) Operating temperature $-40^\circ\text{C} \leq T_A \leq +85^\circ\text{C}$ for Industrial $-40^\circ\text{C} \leq T_A \leq +105^\circ\text{C}$ for V-Temp | | | | |
|--------------------|--------|-----------------------|---|------------------------|------|-------|---------------------------|
| Param. No. | Symbol | Characteristics | Min. | Typical ⁽¹⁾ | Max. | Units | Conditions |
| DO56 | CIO | All I/O pins and OSC2 | — | — | 50 | pF | EC mode |
| DO58 | CB | SCLx, SDAx | — | — | 400 | pF | In I ² C™ mode |

Note 1: Data in “Typical” column is at 3.3V, 25°C unless otherwise stated. Parameters are for design guidance only and are not tested.

FIGURE 29-2: EXTERNAL CLOCK TIMING



PIC32MX3XX/4XX

TABLE 29-17: EXTERNAL CLOCK TIMING REQUIREMENTS

| AC CHARACTERISTICS | | | Standard Operating Conditions: 2.3V to 3.6V (unless otherwise stated) Operating temperature -40°C ≤TA ≤+85°C for Industrial -40°C ≤TA ≤+105°C for V-Temp | | | | |
|--------------------|---------------|--|---|------------------------|--|------------|---|
| Param. No. | Symbol | Characteristics | Min. | Typical ⁽¹⁾ | Max. | Units | Conditions |
| OS10 | Fosc | External CLKI Frequency (External clocks allowed only in EC and ECPLL modes) | DC 4 | — — | 50 ⁽³⁾ 50 ⁽⁵⁾ | MHz MHz | EC (Note 5) ECPLL (Note 4) |
| OS11 | | Oscillator Crystal Frequency | 3 | — | 10 | MHz | XT (Note 5) |
| OS12 | | | 4 | — | 10 | MHz | XTPLL (Notes 4, 5) |
| OS13 | | | 10 | — | 25 | MHz | HS (Note 5) |
| OS14 | | | 10 | — | 25 | MHz | HSPLL (Notes 4, 5) |
| OS15 | | | 32 | 32.768 | 100 | kHz | Sosc (Note 5) |
| OS20 | Tosc | Tosc = 1/Fosc = Tcy ⁽²⁾ | — | — | — | — | See parameter OS10 for Fosc value |
| OS30 | TosL, TosH | External Clock In (OSC1) High or Low Time | 0.45 x Tosc | — | — | ns | EC (Note 5) |
| OS31 | TosR, TosF | External Clock In (OSC1) Rise or Fall Time | — | — | 0.05 x Tosc | ns | EC (Note 5) |
| OS40 | TOST | Oscillator Start-up Timer Period (Only applies to HS, HSPLL, XT, XTPLL and Sosc Clock Oscillator modes) | — | 1024 | — | Tosc | (Note 5) |
| OS41 | TFSCM | Primary Clock Fail Safe Time-out Period | — | 2 | — | ms | (Note 5) |
| OS42 | GM | External Oscillator Transconductance | — | 12 | — | mA/V | VDD = 3.3V TA = +25°C (Note 5) |

Note 1: Data in "Typical" column is at 3.3V, 25°C unless otherwise stated. Parameters are characterized but are not tested.

- 2:** Instruction cycle period (Tcy) equals the input oscillator time base period. All specified values are based on characterization data for that particular oscillator type under standard operating conditions with the device executing code. Exceeding these specified limits may result in an unstable oscillator operation and/or higher than expected current consumption. All devices are tested to operate at "min." values with an external clock applied to the OSC1/CLKI pin.
- 3:** 40 MHz maximum for PIC32MX320F032H and PIC32MX420F032H devices.
- 4:** PLL input requirements: 4 MHz ≤F_{PLLIN} ≤5 MHz (use PLL prescaler to reduce Fosc). This parameter is characterized, but tested at 10 MHz only at manufacturing.
- 5:** This parameter is characterized, but not tested in manufacturing.

TABLE 29-18: PLL CLOCK TIMING SPECIFICATIONS (VDD = 2.3V TO 3.6V)

| AC CHARACTERISTICS | | Standard Operating Conditions: 2.3V to 3.6V (unless otherwise stated) Operating temperature -40°C ≤TA ≤+85°C for Industrial -40°C ≤TA ≤+105°C for V-Temp | | | | | |
|--------------------|--------|---|-------|---------|-------|-------|-----------------------------------|
| Param. No. | Symbol | Characteristics ⁽¹⁾ | Min. | Typical | Max. | Units | Conditions |
| OS50 | FPLLI | PLL Voltage Controlled Oscillator (VCO) Input Frequency Range | 4 | — | 5 | MHz | ECPLL, HSPLL, XTPLL, FRCPLL modes |
| OS51 | FSYS | On-Chip VCO System Frequency | 60 | — | 120 | MHz | — |
| OS52 | TLOCK | PLL Start-up Time (Lock Time) | — | — | 2 | ms | — |
| OS53 | DCLK | CLKO Stability ⁽²⁾ (Period Jitter or Cumulative) | -0.25 | — | +0.25 | % | Measured over 100 ms period |

Note 1: These parameters are characterized, but not tested in manufacturing.

Note 2: This jitter specification is based on clock-cycle by clock-cycle measurements. To get the effective jitter for individual time-bases on communication clocks, use the following formula:

$$EffectiveJitter = \frac{D_{CLK}}{\sqrt{\frac{SYSCLK}{CommunicationClock}}}$$

For example, if SYSCLK = 80 MHz and SPI bit rate = 20 MHz, the effective jitter is as follows:

$$EffectiveJitter = \frac{D_{CLK}}{\sqrt{\frac{80}{20}}} = \frac{D_{CLK}}{2}$$

TABLE 29-19: INTERNAL FRC ACCURACY

| AC CHARACTERISTICS | | Standard Operating Conditions: 2.3V to 3.6V (unless otherwise stated) Operating temperature -40°C ≤TA ≤+85°C for Industrial -40°C ≤TA ≤+105°C for V-Temp | | | | | |
|---|-----------------|---|---------|------|-------|------------|--|
| Param. No. | Characteristics | Min. | Typical | Max. | Units | Conditions | |
| Internal FRC Accuracy @ 8.00 MHz⁽¹⁾ | | | | | | | |
| F20 | FRC | -2 | — | +2 | % | — | |

Note 1: Frequency calibrated at 25°C and 3.3V. TUN bits can be used to compensate for temperature drift.

TABLE 29-20: INTERNAL RC ACCURACY

| AC CHARACTERISTICS | | Standard Operating Conditions: 2.3V to 3.6V (unless otherwise stated) Operating temperature -40°C ≤TA ≤+85°C for Industrial -40°C ≤TA ≤+105°C for V-Temp | | | | | |
|---------------------------------------|-----------------|---|---------|------|-------|------------|--|
| Param. No. | Characteristics | Min. | Typical | Max. | Units | Conditions | |
| LPRC @ 31.25 kHz⁽¹⁾ | | | | | | | |
| F21 | LPRC | -15 | — | +15 | % | — | |

Note 1: Change of LPRC frequency as VDD changes.

PIC32MX3XX/4XX

FIGURE 29-3: I/O TIMING CHARACTERISTICS

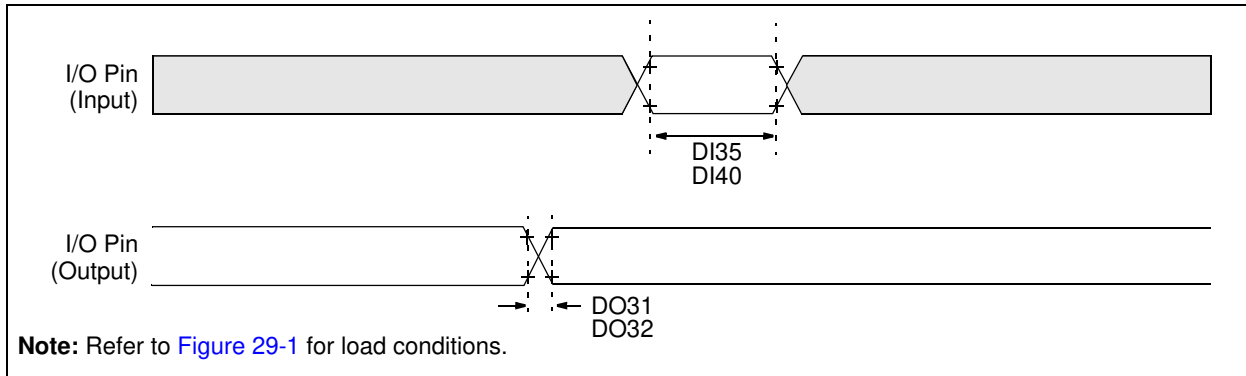

TABLE 29-21: I/O TIMING REQUIREMENTS

| AC CHARACTERISTICS | | Standard Operating Conditions: 2.3V to 3.6V (unless otherwise stated) Operating temperature -40°C ≤TA ≤+85°C for Industrial -40°C ≤TA ≤+105°C for V-Temp | | | | | |
|--------------------|--------|---|------|------------------------|------|---------------------|------------|
| Param. No. | Symbol | Characteristics ⁽²⁾ | Min. | Typical ⁽¹⁾ | Max. | Units | Conditions |
| DO31 | TioR | Port Output Rise Time | — | 5 | 15 | ns | VDD < 2.5V |
| | | | — | 5 | 10 | ns | VDD > 2.5V |
| DO32 | TioF | Port Output Fall Time | — | 5 | 15 | ns | VDD < 2.5V |
| | | | — | 5 | 10 | ns | VDD > 2.5V |
| DI35 | TINP | INTx Pin High or Low Time | 10 | — | — | ns | — |
| DI40 | TRBP | CNx High or Low Time (input) | 2 | — | — | T _{SYSLCK} | — |

Note 1: Data in "Typical" column is at 3.3V, 25°C unless otherwise stated.

Note 2: This parameter is characterized, but not tested in manufacturing.

FIGURE 29-4: POWER-ON RESET TIMING CHARACTERISTICS

Internal Voltage Regulator Enabled
Clock Sources = (FRC, FRCDIV, FRCDIV16, FRCPLL, EC, ECPLL and LPRC)

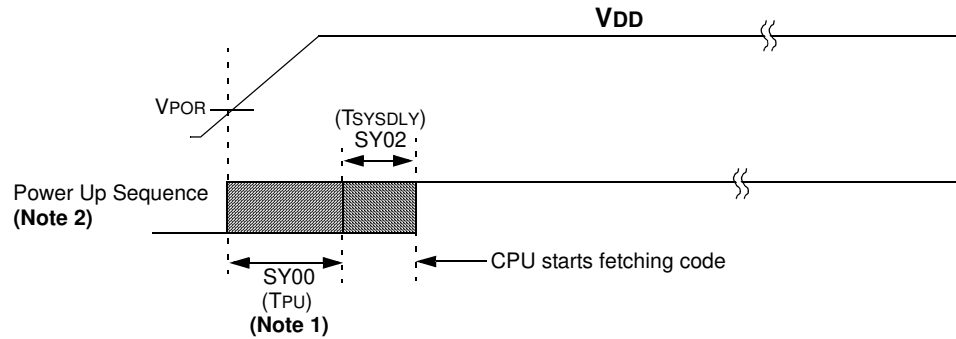

Internal Voltage Regulator Enabled
Clock Sources = (HS, HSPLL, XT, XTPLL and Sosc)

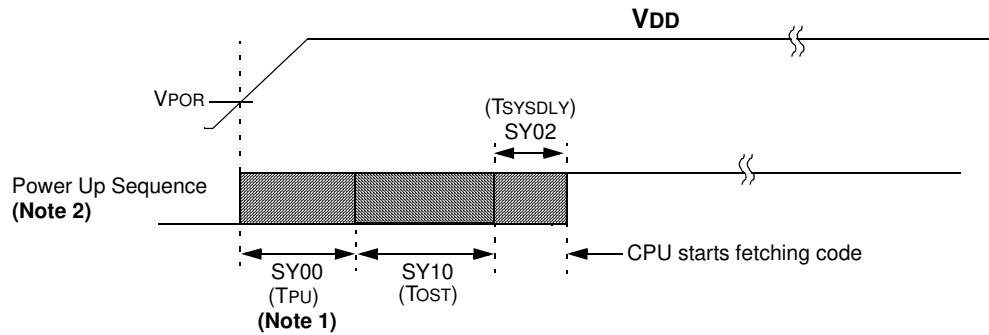

External V_{CORE} Provided
Clock Sources = (FRC, FRCDIV, FRCDIV16, FRCPLL, EC, ECPLL and LPRC)

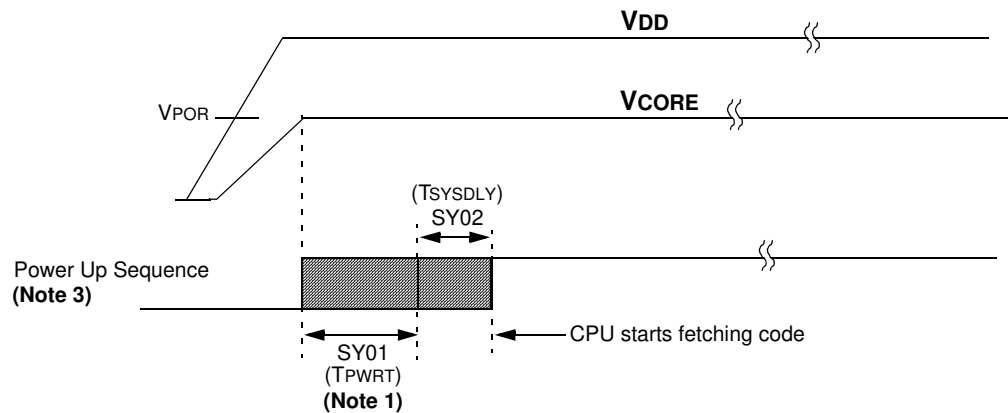

- Note 1:** The Power-up period will be extended if the power-up sequence completes before the device exits from BOR ($V_{DD} < V_{DDMIN}$).
- 2:** Includes interval voltage regulator stabilization delay.
- 3:** Power-up Timer (PWRT); only active when the internal voltage regulator is disabled.

PIC32MX3XX/4XX

FIGURE 29-5: EXTERNAL RESET TIMING CHARACTERISTICS

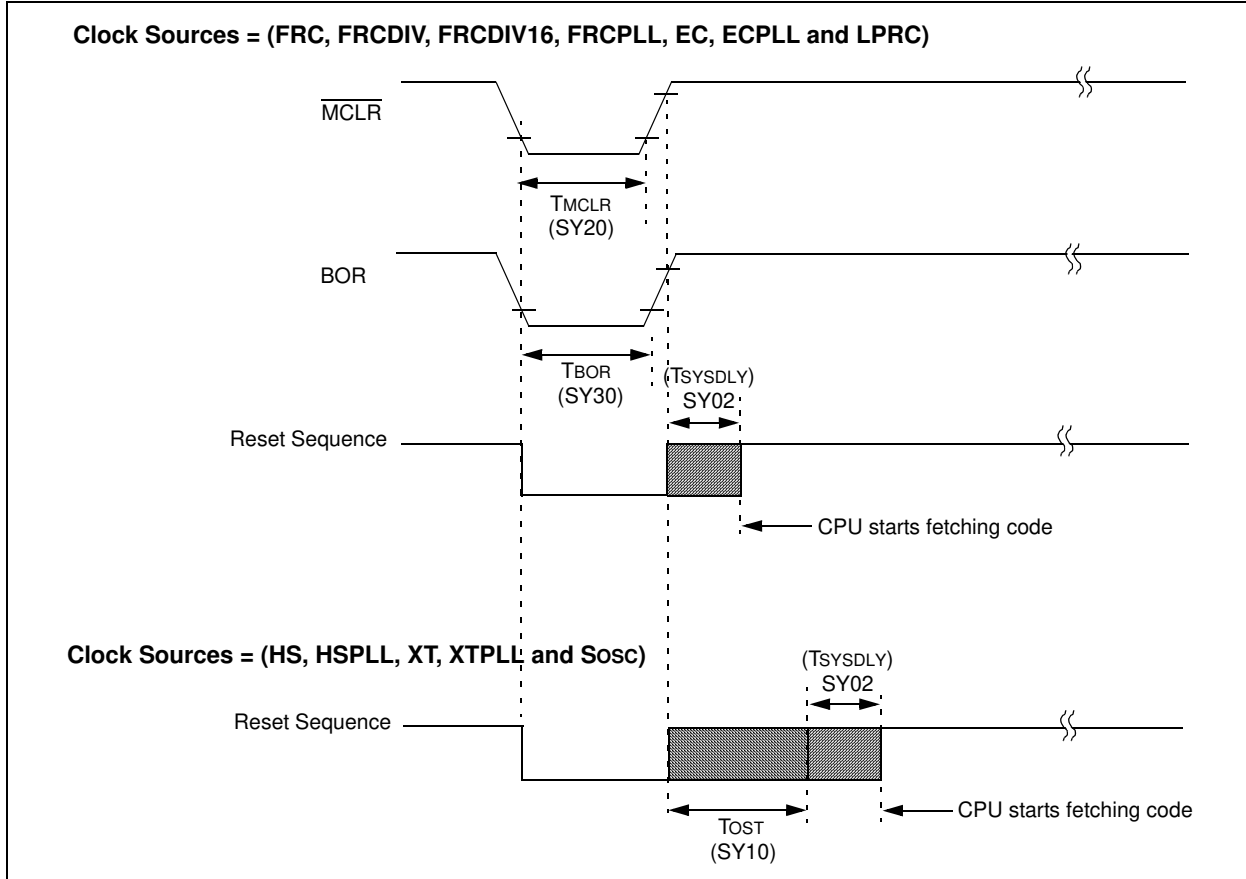

TABLE 29-22: RESETS TIMING

| AC CHARACTERISTICS | | | Standard Operating Conditions: 2.3V to 3.6V (unless otherwise stated) Operating temperature -40°C ≤ TA ≤ +85°C for Industrial -40°C ≤ TA ≤ +105°C for V-Temp | | | | |
|--------------------|---------|--|---|---------------------------------|------|-------|----------------|
| Param. No. | Symbol | Characteristics ⁽¹⁾ | Min. | Typical ⁽²⁾ | Max. | Units | Conditions |
| SY00 | TPU | Power-up Period Internal Voltage Regulator Enabled | — | 400 | 600 | μs | -40°C to +85°C |
| SY01 | TPWRT | Power-up Period External Vcore Applied (Power-Up-Timer Active) | 48 | 64 | 80 | ms | -40°C to +85°C |
| SY02 | TSYSDLY | System Delay Period: Time required to reload Device Configuration Fuses plus SYSCLK delay before first instruction is fetched. | — | 1 μs + 8 SYSCLK cycles | — | — | -40°C to +85°C |
| SY20 | TMCLR | MCLR Pulse Width (low) | — | 2 | — | μs | -40°C to +85°C |
| SY30 | TBOR | BOR Pulse Width (low) | — | 1 | — | μs | -40°C to +85°C |

Note 1: These parameters are characterized, but not tested in manufacturing.

Note 2: Data in “Typ” column is at 3.3V, 25°C unless otherwise stated. Characterized by design but not tested.

FIGURE 29-6: TIMER1, 2, 3, 4, 5 EXTERNAL CLOCK TIMING CHARACTERISTICS

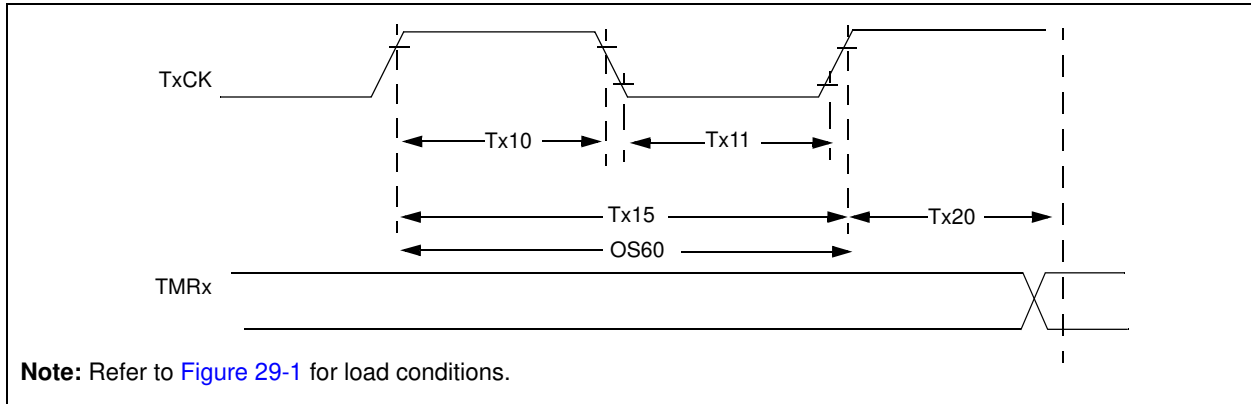

Note: Refer to [Figure 29-1](#) for load conditions.

TABLE 29-23: TIMER1 EXTERNAL CLOCK TIMING REQUIREMENTS⁽¹⁾

| AC CHARACTERISTICS | | Standard Operating Conditions: 2.3V to 3.6V (unless otherwise stated) Operating temperature -40°C ≤ TA ≤ +85°C for Industrial -40°C ≤ TA ≤ +105°C for V-Temp | | | | | | |
|--------------------|-----------------|---|------------------------------|--|---------|------|-------|---|
| Param. No. | Symbol | Characteristics ⁽²⁾ | | Min. | Typical | Max. | Units | Conditions |
| TA10 | TTXH | TxCK High Time | Synchronous, with prescaler | $[(12.5 \text{ ns or } 1\text{TPB})/N] + 25 \text{ ns}$ | — | — | ns | Must also meet parameter TA15. |
| | | | Asynchronous, with prescaler | 10 | — | — | ns | — |
| TA11 | TTXL | TxCK Low Time | Synchronous, with prescaler | $[(12.5 \text{ ns or } 1\text{TPB})/N] + 25 \text{ ns}$ | — | — | ns | Must also meet parameter TA15. |
| | | | Asynchronous, with prescaler | 10 | — | — | ns | — |
| TA15 | TTXP | TxCK Input Period | Synchronous, with prescaler | $[(\text{Greater of } 25 \text{ ns or } 2\text{TPB})/N] + 30 \text{ ns}$ | — | — | ns | V _{DD} > 2.7V |
| | | | | $[(\text{Greater of } 25 \text{ ns or } 2\text{TPB})/N] + 50 \text{ ns}$ | — | — | ns | V _{DD} < 2.7V |
| | | | Asynchronous, with prescaler | 20 | — | — | ns | V _{DD} > 2.7V (Note 3) |
| | | | | 50 | — | — | ns | V _{DD} < 2.7V (Note 3) |
| OS60 | F _{T1} | SOSC1/T1CK Oscillator Input Frequency Range (oscillator enabled by setting TCS bit (T1CON<1>)) | | 32 | — | 100 | kHz | — |
| TA20 | TCKEXTMRL | Delay from External TxCK Clock Edge to Timer Increment | | — | — | 1 | TPB | — |

Note 1: Timer1 is a Type A.

Note 2: This parameter is characterized, but not tested in manufacturing.

Note 3: N = prescale value (1, 8, 64, 256)

PIC32MX3XX/4XX

TABLE 29-24: TIMER2, 3, 4, 5 EXTERNAL CLOCK TIMING REQUIREMENTS

| AC CHARACTERISTICS | | | Standard Operating Conditions: 2.3V to 3.6V (unless otherwise stated) Operating temperature -40°C ≤TA ≤+85°C for Industrial -40°C ≤TA ≤+105°C for V-Temp | | | | | |
|--------------------|-----------|--|---|--|-------|------------|--------------------------------|--|
| Param. No. | Symbol | Characteristics ⁽¹⁾ | Min. | Max. | Units | Conditions | | |
| TB10 | TTXH | TxCK High Time | Synchronous, with prescaler | $[(12.5 \text{ ns or } 1\text{TPB})/N] + 25 \text{ ns}$ | — | ns | Must also meet parameter TB15. | N = prescale value (1, 2, 4, 8, 16, 32, 64, 256) |
| TB11 | TTXL | TxCK Low Time | Synchronous, with prescaler | $[(12.5 \text{ ns or } 1\text{TPB})/N] + 25 \text{ ns}$ | — | ns | Must also meet parameter TB15. | |
| TB15 | TTXP | TxCK Input Period | Synchronous, with prescaler | $[(\text{Greater of } 25 \text{ ns or } 2 \text{ TPB})/N] + 30 \text{ ns}$ | — | ns | VDD > 2.7V | |
| | | | | $[(\text{Greater of } 25 \text{ ns or } 2 \text{ TPB})/N] + 50 \text{ ns}$ | — | ns | VDD < 2.7V | — |
| TB20 | TCKEXTMRL | Delay from External TxCK Clock Edge to Timer Increment | — | 1 | TPB | — | | |

Note 1: These parameters are characterized, but not tested in manufacturing.

FIGURE 29-7: INPUT CAPTURE (CAPx) TIMING CHARACTERISTICS

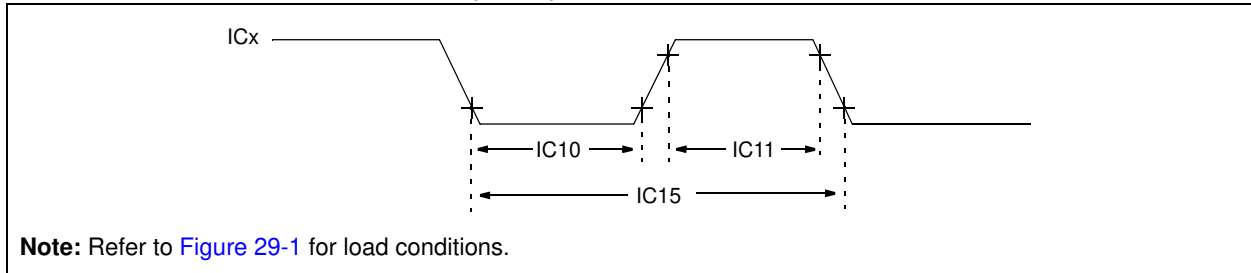

TABLE 29-25: INPUT CAPTURE MODULE TIMING REQUIREMENTS

| AC CHARACTERISTICS | | Standard Operating Conditions: 2.3V to 3.6V (unless otherwise stated) Operating temperature -40°C ≤TA ≤+85°C for Industrial -40°C ≤TA ≤+105°C for V-Temp | | | | |
|--------------------|--------|---|---|------|-------|---|
| Param. No. | Symbol | Characteristics ⁽¹⁾ | Min. | Max. | Units | Conditions |
| IC10 | TccL | ICx Input Low Time | $[(12.5 \text{ ns or } 1\text{TPB})/N] + 25 \text{ ns}$ | — | ns | Must also meet parameter IC15. N = prescale value (1, 4, 16) |
| IC11 | TccH | ICx Input High Time | $[(12.5 \text{ ns or } 1\text{TPB})/N] + 25 \text{ ns}$ | — | ns | Must also meet parameter IC15. |
| IC15 | TccP | ICx Input Period | $[(25 \text{ ns or } 2\text{TPB})/N] + 50 \text{ ns}$ | — | ns | — |

Note 1: These parameters are characterized, but not tested in manufacturing.

FIGURE 29-8: OUTPUT COMPARE MODULE (OCx) TIMING CHARACTERISTICS

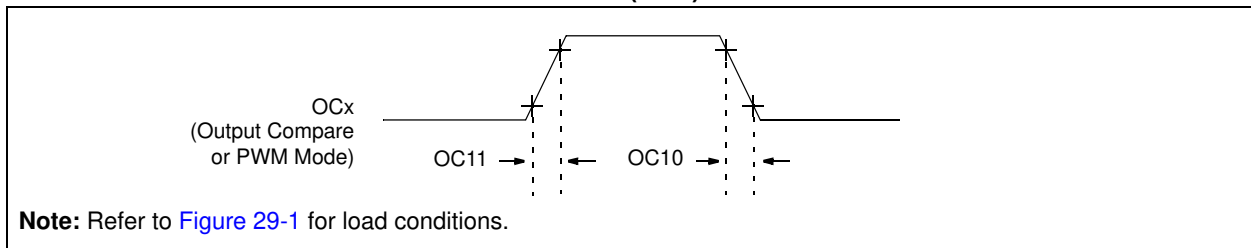

TABLE 29-26: OUTPUT COMPARE MODULE TIMING REQUIREMENTS

| AC CHARACTERISTICS | | Standard Operating Conditions: 2.3V to 3.6V (unless otherwise stated) Operating temperature -40°C ≤TA ≤+85°C for Industrial -40°C ≤TA ≤+105°C for V-Temp | | | | | |
|--------------------|--------|---|------|------------------------|------|-------|---------------------|
| Param. No. | Symbol | Characteristics ⁽¹⁾ | Min. | Typical ⁽²⁾ | Max. | Units | Conditions |
| OC10 | TccF | OCx Output Fall Time | — | — | — | ns | See parameter DO32. |
| OC11 | TccR | OCx Output Rise Time | — | — | — | ns | See parameter DO31. |

Note 1: These parameters are characterized, but not tested in manufacturing.

2: Data in “Typical” column is at 3.3V, 25°C unless otherwise stated. Parameters are for design guidance only and are not tested.

PIC32MX3XX/4XX

FIGURE 29-9: OC/PWM MODULE TIMING CHARACTERISTICS

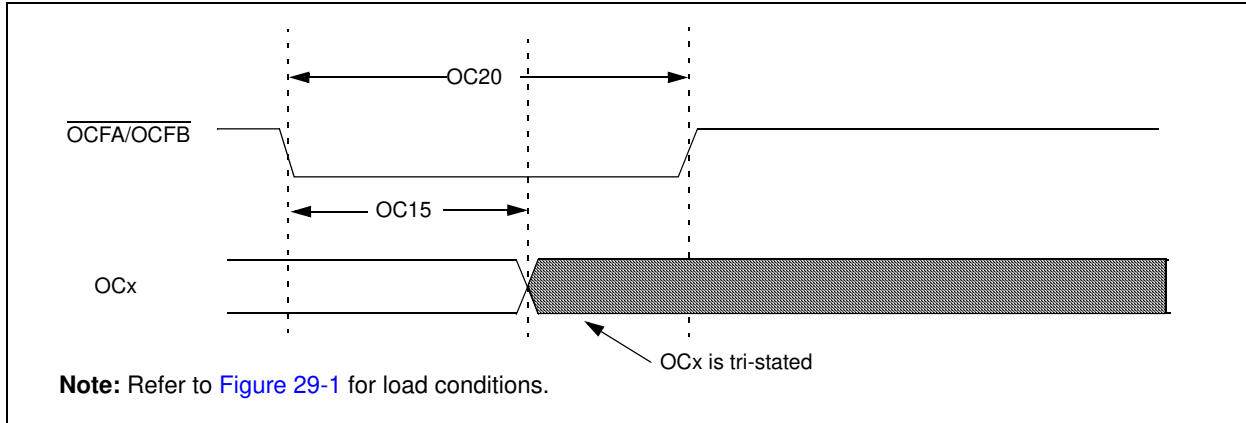

TABLE 29-27: SIMPLE OC/PWM MODE TIMING REQUIREMENTS

| AC CHARACTERISTICS | | | Standard Operating Conditions: 2.3V to 3.6V (unless otherwise stated) Operating temperature -40°C ≤TA ≤+85°C for Industrial -40°C ≤TA ≤+105°C for V-Temp | | | | |
|--------------------|--------|--------------------------------|---|------------------------|-----|-------|------------|
| Param No. | Symbol | Characteristics ⁽¹⁾ | Min | Typical ⁽²⁾ | Max | Units | Conditions |
| OC15 | TFD | Fault Input to PWM I/O Change | — | — | 25 | ns | — |
| OC20 | TFLT | Fault Input Pulse Width | 50 | — | — | ns | — |

Note 1: These parameters are characterized, but not tested in manufacturing.

Note 2: Data in "Typical" column is at 3.3V, 25°C unless otherwise stated. Parameters are for design guidance only and are not tested.

FIGURE 29-10: SPIx MODULE MASTER MODE (CKE = 0) TIMING CHARACTERISTICS

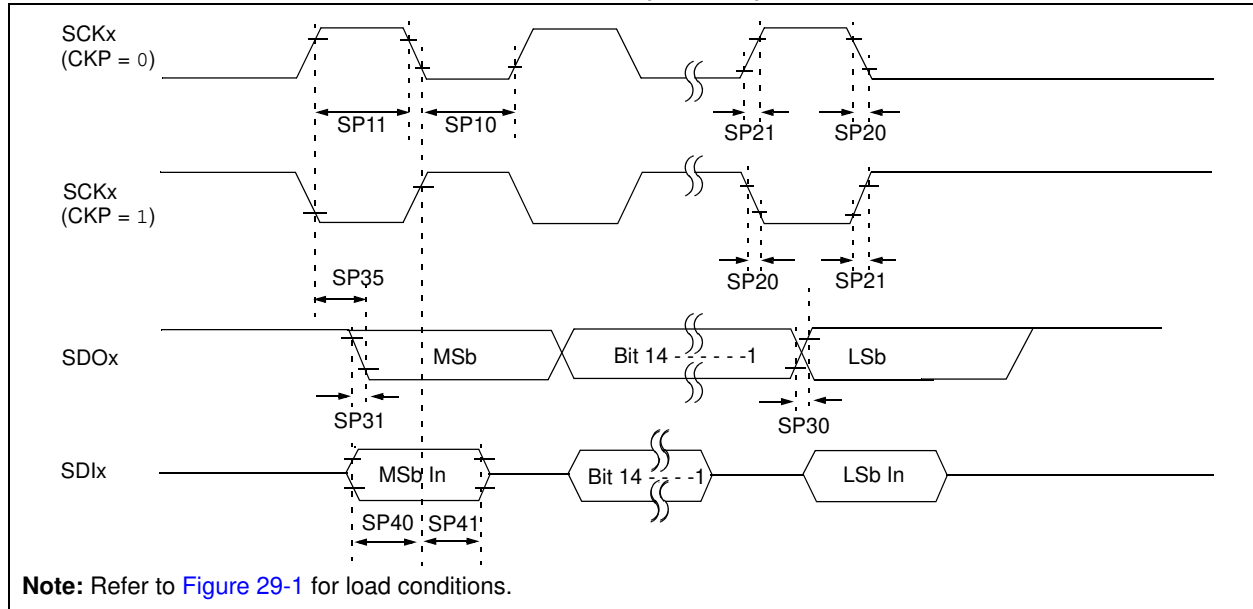

TABLE 29-28: SPIx MASTER MODE (CKE = 0) TIMING REQUIREMENTS

| AC CHARACTERISTICS | | | Standard Operating Conditions: 2.3V to 3.6V (unless otherwise stated) Operating temperature -40°C ≤ TA ≤ +85°C for Industrial -40°C ≤ TA ≤ +105°C for V-Temp | | | | |
|--------------------|-----------------------|--|---|------------------------|------|-------|--------------------|
| Param. No. | Symbol | Characteristics ⁽¹⁾ | Min. | Typical ⁽²⁾ | Max. | Units | Conditions |
| SP10 | TsCL | SCKx Output Low Time ⁽³⁾ | Tsck/2 | — | — | ns | — |
| SP11 | TsCH | SCKx Output High Time ⁽³⁾ | Tsck/2 | — | — | ns | — |
| SP20 | TscF | SCKx Output Fall Time ⁽⁴⁾ | — | — | — | ns | See parameter DO32 |
| SP21 | TscR | SCKx Output Rise Time ⁽⁴⁾ | — | — | — | ns | See parameter DO31 |
| SP30 | TdoF | SDOx Data Output Fall Time ⁽⁴⁾ | — | — | — | ns | See parameter DO32 |
| SP31 | TdoR | SDOx Data Output Rise Time ⁽⁴⁾ | — | — | — | ns | See parameter DO31 |
| SP35 | Tsch2doV, TscL2doV | SDOx Data Output Valid after SCKx Edge | — | — | 15 | ns | VDD > 2.7V |
| | | | — | — | 20 | ns | VDD < 2.7V |
| SP40 | TdiV2sch, TdiV2scl | Setup Time of SDIx Data Input to SCKx Edge | 10 | — | — | ns | — |
| SP41 | Tsch2diL, TscL2diL | Hold Time of SDIx Data Input to SCKx Edge | 10 | — | — | ns | — |

- Note 1:** These parameters are characterized, but not tested in manufacturing.
- 2:** Data in “Typical” column is at 3.3V, 25°C unless otherwise stated. Parameters are for design guidance only and are not tested.
- 3:** The minimum clock period for SCKx is 40 ns. Therefore, the clock generated in Master mode must not violate this specification.
- 4:** Assumes 50 pF load on all SPIx pins.

PIC32MX3XX/4XX

FIGURE 29-11: SPIx MODULE MASTER MODE (CKE = 1) TIMING CHARACTERISTICS

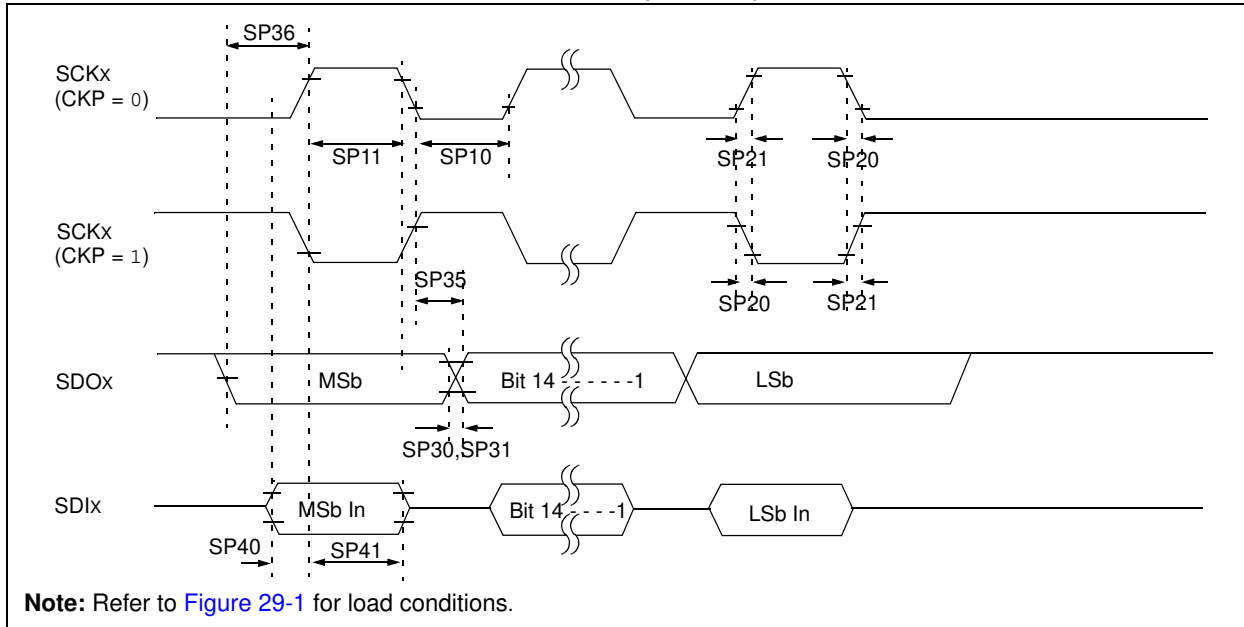

TABLE 29-29: SPIx MODULE MASTER MODE (CKE = 1) TIMING REQUIREMENTS

| AC CHARACTERISTICS | | | Standard Operating Conditions: 2.3V to 3.6V (unless otherwise stated) Operating temperature -40°C ≤TA ≤+85°C for Industrial -40°C ≤TA ≤+105°C for V-Temp | | | | |
|--------------------|-----------------------|---|---|------------------------|------|-------|--------------------|
| Param. No. | Symbol | Characteristics ⁽¹⁾ | Min. | Typical ⁽²⁾ | Max. | Units | Conditions |
| SP10 | TsCL | SCKx Output Low Time ⁽³⁾ | TsCK/2 | — | — | ns | — |
| SP11 | TsCH | SCKx Output High Time ⁽³⁾ | TsCK/2 | — | — | ns | — |
| SP20 | TscF | SCKx Output Fall Time ⁽⁴⁾ | — | — | — | ns | See parameter DO32 |
| SP21 | TscR | SCKx Output Rise Time ⁽⁴⁾ | — | — | — | ns | See parameter DO31 |
| SP30 | TdoF | SDOx Data Output Fall Time ⁽⁴⁾ | — | — | — | ns | See parameter DO32 |
| SP31 | TdoR | SDOx Data Output Rise Time ⁽⁴⁾ | — | — | — | ns | See parameter DO31 |
| SP35 | Tsch2doV, TscL2doV | SDOx Data Output Valid after SCKx Edge | — | — | 15 | ns | VDD > 2.7V |
| | | | — | — | 20 | ns | VDD < 2.7V |
| SP36 | TdoV2sc, TdoV2sCL | SDOx Data Output Setup to First SCKx Edge | 15 | — | — | ns | — |
| SP40 | TdiV2sch, TdiV2sCL | Setup Time of SDIx Data Input to SCKx Edge | 15 | — | — | ns | VDD > 2.7V |
| | | | 20 | — | — | ns | VDD < 2.7V |
| SP41 | Tsch2diL, TscL2diL | Hold Time of SDIx Data Input to SCKx Edge | 15 | — | — | ns | VDD > 2.7V |
| | | | 20 | — | — | ns | VDD < 2.7V |

Note 1: These parameters are characterized, but not tested in manufacturing.

Note 2: Data in “Typical” column is at 3.3V, 25°C unless otherwise stated. Parameters are for design guidance only and are not tested.

Note 3: The minimum clock period for SCKx is 40 ns. Therefore, the clock generated in Master mode must not violate this specification.

Note 4: Assumes 50 pF load on all SPIx pins.

FIGURE 29-12: SPIx MODULE SLAVE MODE (CKE = 0) TIMING CHARACTERISTICS

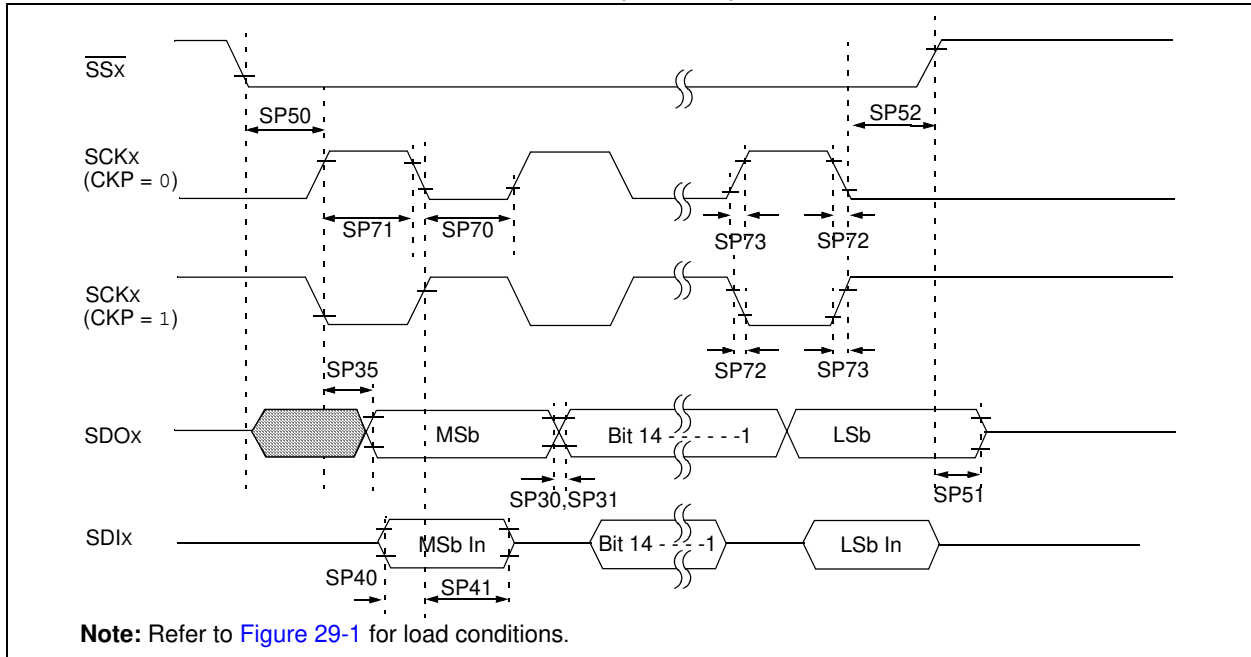

TABLE 29-30: SPIx MODULE SLAVE MODE (CKE = 0) TIMING REQUIREMENTS

| AC CHARACTERISTICS | | | Standard Operating Conditions: 2.3V to 3.6V (unless otherwise stated) Operating temperature -40°C ≤ TA ≤ +85°C for Industrial -40°C ≤ TA ≤ +105°C for V-Temp | | | | |
|--------------------|-----------------------|--|---|------------------------|------|-------|--------------------|
| Param. No. | Symbol | Characteristics ⁽¹⁾ | Min. | Typical ⁽²⁾ | Max. | Units | Conditions |
| SP70 | TsCL | SCKx Input Low Time ⁽³⁾ | Tsck/2 | — | — | ns | — |
| SP71 | TsCH | SCKx Input High Time ⁽³⁾ | Tsck/2 | — | — | ns | — |
| SP72 | TscF | SCKx Input Fall Time | — | — | — | ns | See parameter DO32 |
| SP73 | TscR | SCKx Input Rise Time | — | — | — | ns | See parameter DO31 |
| SP30 | TdoF | SDOx Data Output Fall Time ⁽⁴⁾ | — | — | — | ns | See parameter DO32 |
| SP31 | TdoR | SDOx Data Output Rise Time ⁽⁴⁾ | — | — | — | ns | See parameter DO31 |
| SP35 | Tsch2DoV, Tscl2DoV | SDOx Data Output Valid after SCKx Edge | — | — | 15 | ns | VDD > 2.7V |
| | | | — | — | 20 | ns | VDD < 2.7V |
| SP40 | TdiV2sCH, TdiV2sCL | Setup Time of SDIx Data Input to SCKx Edge | 10 | — | — | ns | — |
| SP41 | Tsch2DiL, Tscl2DiL | Hold Time of SDIx Data Input to SCKx Edge | 10 | — | — | ns | — |
| SP50 | TssL2sCH, TssL2sCL | SSx ↓ to SCKx ↑ or SCKx Input | 175 | — | — | ns | — |
| SP51 | TssH2DoZ | SSx ↑ to SDOx Output High-Impedance ⁽³⁾ | 5 | — | 25 | ns | — |
| SP52 | Tsch2ssH, Tscl2ssH | SSx after SCKx Edge | Tsck + 20 | — | — | ns | — |

Note 1: These parameters are characterized, but not tested in manufacturing.

Note 2: Data in “Typical” column is at 3.3V, 25°C unless otherwise stated. Parameters are for design guidance only and are not tested.

Note 3: The minimum clock period for SCKx is 40 ns.

Note 4: Assumes 50 pF load on all SPIx pins.

PIC32MX3XX/4XX

FIGURE 29-13: SPIx MODULE SLAVE MODE (CKE = 1) TIMING CHARACTERISTICS

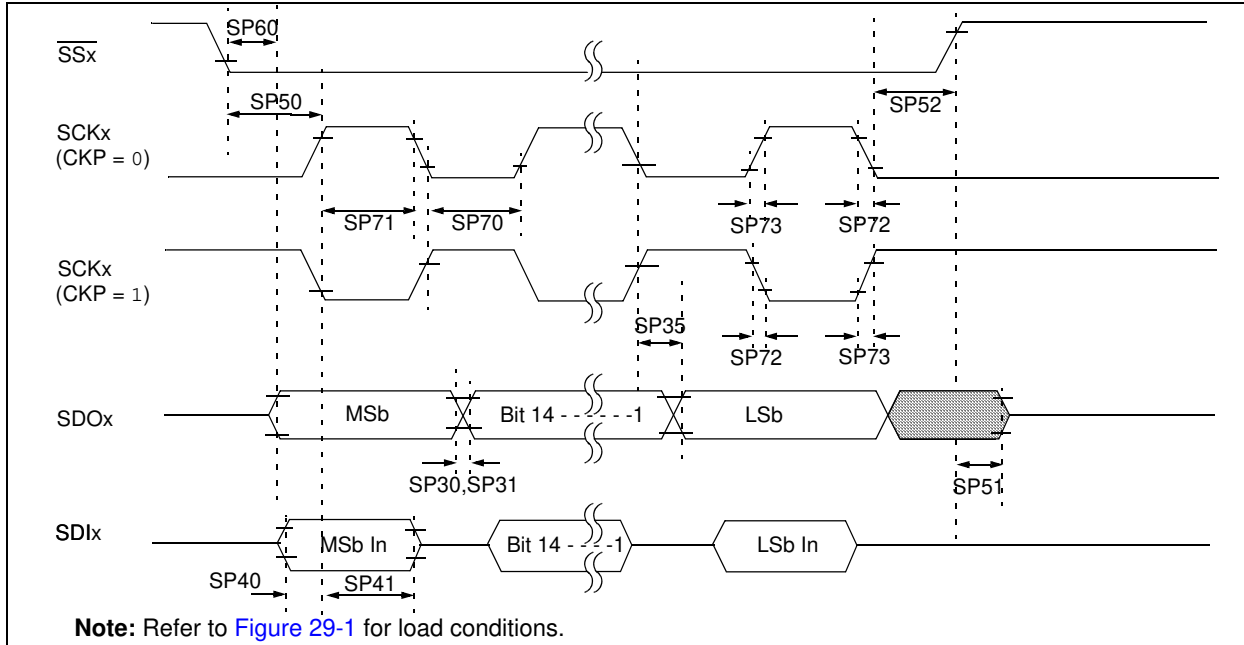

TABLE 29-31: SPIx MODULE SLAVE MODE (CKE = 1) TIMING REQUIREMENTS

| AC CHARACTERISTICS | | | Standard Operating Conditions: 2.3V to 3.6V (unless otherwise stated) Operating temperature -40°C ≤ TA ≤ +85°C for Industrial -40°C ≤ TA ≤ +105°C for V-Temp | | | | |
|--------------------|-----------------------|--|---|------------------------|------|-------|--------------------|
| Param. No. | Symbol | Characteristics ⁽¹⁾ | Min. | Typical ⁽²⁾ | Max. | Units | Conditions |
| SP70 | TsCL | SCKx Input Low Time ⁽³⁾ | TsCK/2 | — | — | ns | — |
| SP71 | TsCH | SCKx Input High Time ⁽³⁾ | TsCK/2 | — | — | ns | — |
| SP72 | TscF | SCKx Input Fall Time | — | 5 | 10 | ns | — |
| SP73 | TscR | SCKx Input Rise Time | — | 5 | 10 | ns | — |
| SP30 | TdOF | SDOx Data Output Fall Time ⁽⁴⁾ | — | — | — | ns | See parameter DO32 |
| SP31 | TdOR | SDOx Data Output Rise Time ⁽⁴⁾ | — | — | — | ns | See parameter DO31 |
| SP35 | TsCH2doV, TsCL2doV | SDOx Data Output Valid after SCKx Edge | — | — | 20 | ns | VDD > 2.7V |
| | | | — | — | 30 | ns | VDD < 2.7V |
| SP40 | TdIV2sCH, TdIV2sCL | Setup Time of SDIx Data Input to SCKx Edge | 10 | — | — | ns | — |
| SP41 | TsCH2dIL, TsCL2dIL | Hold Time of SDIx Data Input to SCKx Edge | 10 | — | — | ns | — |
| SP50 | TssL2sCH, TssL2sCL | SSx ↓ to SCKx ↓ or SCKx ↑ Input | 175 | — | — | ns | — |
| SP51 | TssH2doZ | SSx ↑ to SDOx Output High-Impedance ⁽⁴⁾ | 5 | — | 25 | ns | — |
| SP52 | TsCH2ssH TsCL2ssH | SSx ↑ after SCKx Edge | TsCK + | — | — | ns | — |
| | | | 20 | — | — | ns | — |
| SP60 | TssL2doV | SDOx Data Output Valid after SSx Edge | — | — | 25 | ns | — |

Note 1: These parameters are characterized, but not tested in manufacturing.

Note 2: Data in "Typical" column is at 3.3V, 25°C unless otherwise stated. Parameters are for design guidance only and are not tested.

Note 3: The minimum clock period for SCKx is 40 ns.

Note 4: Assumes 50 pF load on all SPIx pins.

FIGURE 29-14: I2Cx BUS START/STOP BITS TIMING CHARACTERISTICS (MASTER MODE)

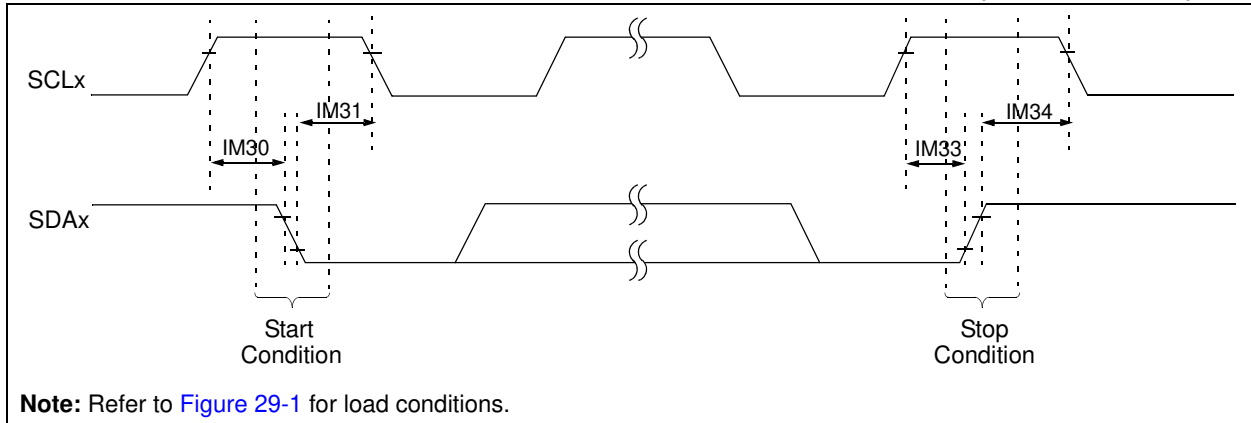
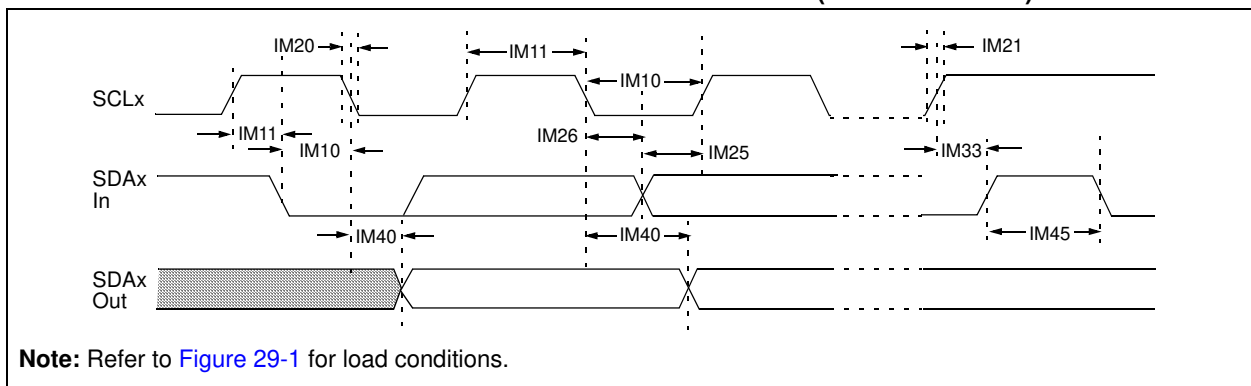

FIGURE 29-15: I2Cx BUS DATA TIMING CHARACTERISTICS (MASTER MODE)



PIC32MX3XX/4XX

TABLE 29-32: I2Cx BUS DATA TIMING REQUIREMENTS (MASTER MODE)

| AC CHARACTERISTICS | | | | Standard Operating Conditions: 2.3V to 3.6V (unless otherwise stated) Operating temperature $-40^{\circ}\text{C} \leq T_A \leq +85^{\circ}\text{C}$ for Industrial $-40^{\circ}\text{C} \leq T_A \leq +105^{\circ}\text{C}$ for V-Temp | | | |
|--------------------|---------|------------------------------------|---------------------------|---|------|---------------|--|
| Param. No. | Symbol | Characteristics | | Min. ⁽¹⁾ | Max. | Units | Conditions |
| IM10 | TLO:SCL | Clock Low Time | 100 kHz mode | $T_{PB} * (BRG + 2)$ | — | μs | — |
| | | | 400 kHz mode | $T_{PB} * (BRG + 2)$ | — | μs | |
| | | | 1 MHz mode ⁽²⁾ | $T_{PB} * (BRG + 2)$ | — | μs | |
| IM11 | THI:SCL | Clock High Time | 100 kHz mode | $T_{PB} * (BRG + 2)$ | — | μs | — |
| | | | 400 kHz mode | $T_{PB} * (BRG + 2)$ | — | μs | |
| | | | 1 MHz mode ⁽²⁾ | $T_{PB} * (BRG + 2)$ | — | μs | |
| IM20 | TF:SCL | SDAx and SCLx Fall Time | 100 kHz mode | — | 300 | ns | Cb is specified to be from 10 to 400 pF. |
| | | | 400 kHz mode | $20 + 0.1 C_b$ | 300 | ns | |
| | | | 1 MHz mode ⁽²⁾ | — | 100 | ns | |
| IM21 | TR:SCL | SDAx and SCLx Rise Time | 100 kHz mode | — | 1000 | ns | Cb is specified to be from 10 to 400 pF. |
| | | | 400 kHz mode | $20 + 0.1 C_b$ | 300 | ns | |
| | | | 1 MHz mode ⁽²⁾ | — | 300 | ns | |
| IM25 | TSU:DAT | Data Input Setup Time | 100 kHz mode | 250 | — | ns | — |
| | | | 400 kHz mode | 100 | — | ns | |
| | | | 1 MHz mode ⁽²⁾ | 100 | — | ns | |
| IM26 | THD:DAT | Data Input Hold Time | 100 kHz mode | 0 | — | μs | — |
| | | | 400 kHz mode | 0 | 0.9 | μs | |
| | | | 1 MHz mode ⁽²⁾ | 0 | 0.3 | μs | |
| IM30 | TSU:STA | Start Condition Setup Time | 100 kHz mode | $T_{PB} * (BRG + 2)$ | — | μs | Only relevant for Repeated Start condition. |
| | | | 400 kHz mode | $T_{PB} * (BRG + 2)$ | — | μs | |
| | | | 1 MHz mode ⁽²⁾ | $T_{PB} * (BRG + 2)$ | — | μs | |
| IM31 | THD:STA | Start Condition Hold Time | 100 kHz mode | $T_{PB} * (BRG + 2)$ | — | μs | After this period, the first clock pulse is generated. |
| | | | 400 kHz mode | $T_{PB} * (BRG + 2)$ | — | μs | |
| | | | 1 MHz mode ⁽²⁾ | $T_{PB} * (BRG + 2)$ | — | μs | |
| IM33 | TSU:STO | Stop Condition Setup Time | 100 kHz mode | $T_{PB} * (BRG + 2)$ | — | μs | — |
| | | | 400 kHz mode | $T_{PB} * (BRG + 2)$ | — | μs | |
| | | | 1 MHz mode ⁽²⁾ | $T_{PB} * (BRG + 2)$ | — | μs | |
| IM34 | THD:STO | Stop Condition Hold Time | 100 kHz mode | $T_{PB} * (BRG + 2)$ | — | ns | — |
| | | | 400 kHz mode | $T_{PB} * (BRG + 2)$ | — | ns | |
| | | | 1 MHz mode ⁽²⁾ | $T_{PB} * (BRG + 2)$ | — | ns | |
| IM40 | TAA:SCL | Output Valid from Clock | 100 kHz mode | — | 3500 | ns | — |
| | | | 400 kHz mode | — | 1000 | ns | |
| | | | 1 MHz mode ⁽²⁾ | — | 350 | ns | |
| IM45 | TBF:SDA | Bus Free Time | 100 kHz mode | 4.7 | — | μs | The amount of time the bus must be free before a new transmission can start. |
| | | | 400 kHz mode | 1.3 | — | μs | |
| | | | 1 MHz mode ⁽²⁾ | 0.5 | — | μs | |
| IM50 | CB | Bus Capacitive Loading | | — | 400 | pF | — |
| IM51 | TPGD | Pulse Gobbler Delay ⁽³⁾ | | 52 | 312 | ns | — |

Note 1: BRG is the value of the I²C™ Baud Rate Generator.

2: Maximum pin capacitance = 10 pF for all I2Cx pins (for 1 MHz mode only).

3: The typical value for this parameter is 104 ns.

FIGURE 29-16: I2Cx BUS START/STOP BITS TIMING CHARACTERISTICS (SLAVE MODE)

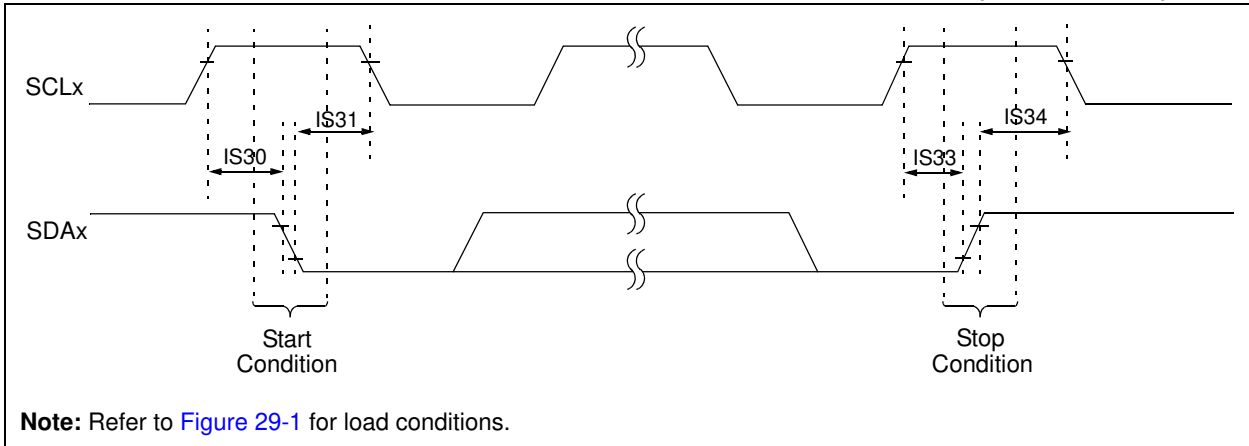
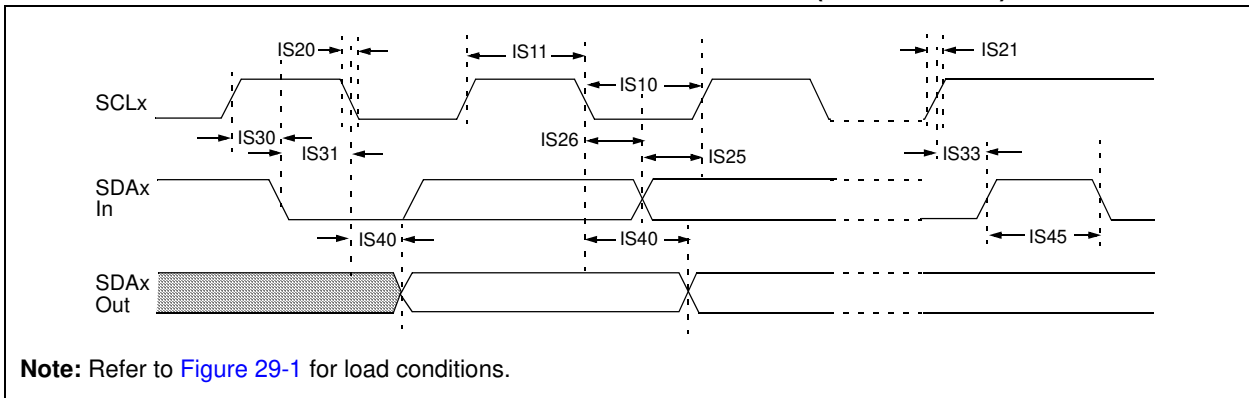

FIGURE 29-17: I2Cx BUS DATA TIMING CHARACTERISTICS (SLAVE MODE)



PIC32MX3XX/4XX

TABLE 29-33: I2Cx BUS DATA TIMING REQUIREMENTS (SLAVE MODE)

| AC CHARACTERISTICS | | | | Standard Operating Conditions: 2.3V to 3.6V (unless otherwise stated) Operating temperature -40°C ≤ TA ≤ +85°C for Industrial -40°C ≤ TA ≤ +105°C for V-Temp | | | |
|--------------------|---------|----------------------------|---------------------------|---|------|-------|--|
| Param. No. | Symbol | Characteristics | | Min. | Max. | Units | Conditions |
| IS10 | TLO:SCL | Clock Low Time | 100 kHz mode | 4.7 | — | μs | PBCLK must operate at a minimum of 800 KHz. |
| | | | 400 kHz mode | 1.3 | — | μs | PBCLK must operate at a minimum of 3.2 MHz. |
| | | | 1 MHz mode ⁽¹⁾ | 0.5 | — | μs | — |
| IS11 | THI:SCL | Clock High Time | 100 kHz mode | 4.0 | — | μs | PBCLK must operate at a minimum of 800 KHz. |
| | | | 400 kHz mode | 0.6 | — | μs | PBCLK must operate at a minimum of 3.2 MHz. |
| | | | 1 MHz mode ⁽¹⁾ | 0.5 | — | μs | — |
| IS20 | TF:SCL | SDAx and SCLx Fall Time | 100 kHz mode | — | 300 | ns | CB is specified to be from 10 to 400 pF. |
| | | | 400 kHz mode | 20 + 0.1 CB | 300 | ns | |
| | | | 1 MHz mode ⁽¹⁾ | — | 100 | ns | |
| IS21 | TR:SCL | SDAx and SCLx Rise Time | 100 kHz mode | — | 1000 | ns | CB is specified to be from 10 to 400 pF. |
| | | | 400 kHz mode | 20 + 0.1 CB | 300 | ns | |
| | | | 1 MHz mode ⁽¹⁾ | — | 300 | ns | |
| IS25 | TSU:DAT | Data Input Setup Time | 100 kHz mode | 250 | — | ns | — |
| | | | 400 kHz mode | 100 | — | ns | |
| | | | 1 MHz mode ⁽¹⁾ | 100 | — | ns | |
| IS26 | THD:DAT | Data Input Hold Time | 100 kHz mode | 0 | — | ns | — |
| | | | 400 kHz mode | 0 | 0.9 | μs | |
| | | | 1 MHz mode ⁽¹⁾ | 0 | 0.3 | μs | |
| IS30 | TSU:STA | Start Condition Setup Time | 100 kHz mode | 4700 | — | ns | Only relevant for Repeated Start condition. |
| | | | 400 kHz mode | 600 | — | ns | |
| | | | 1 MHz mode ⁽¹⁾ | 250 | — | ns | |
| IS31 | THD:STA | Start Condition Hold Time | 100 kHz mode | 4000 | — | ns | After this period, the first clock pulse is generated. |
| | | | 400 kHz mode | 600 | — | ns | |
| | | | 1 MHz mode ⁽¹⁾ | 250 | — | ns | |
| IS33 | TSU:STO | Stop Condition Setup Time | 100 kHz mode | 4000 | — | ns | — |
| | | | 400 kHz mode | 600 | — | ns | |
| | | | 1 MHz mode ⁽¹⁾ | 600 | — | ns | |
| IS34 | THD:STO | Stop Condition Hold Time | 100 kHz mode | 4000 | — | ns | — |
| | | | 400 kHz mode | 600 | — | ns | |
| | | | 1 MHz mode ⁽¹⁾ | 250 | — | ns | |
| IS40 | TAA:SCL | Output Valid from Clock | 100 kHz mode | 0 | 3500 | ns | — |
| | | | 400 kHz mode | 0 | 1000 | ns | |
| | | | 1 MHz mode ⁽¹⁾ | 0 | 350 | ns | |
| IS45 | TBF:SDA | Bus Free Time | 100 kHz mode | 4.7 | — | μs | The amount of time the bus must be free before a new transmission can start. |
| | | | 400 kHz mode | 1.3 | — | μs | |
| | | | 1 MHz mode ⁽¹⁾ | 0.5 | — | μs | |
| IS50 | CB | Bus Capacitive Loading | | — | 400 | pF | — |

Note 1: Maximum pin capacitance = 10 pF for all I2Cx pins (for 1 MHz mode only).

TABLE 29-34: ADC MODULE SPECIFICATIONS

| AC CHARACTERISTICS | | | Standard Operating Conditions: 2.3V to 3.6V (unless otherwise stated) Operating temperature -40°C ≤ TA ≤ +85°C for Industrial -40°C ≤ TA ≤ +105°C for V-Temp | | | | |
|--|-----------|--|---|----------|----------------------------|----------|---|
| Param. No. | Symbol | Characteristics | Min. | Typical | Max. | Units | Conditions |
| Device Supply | | | | | | | |
| AD01 | AVDD | Module VDD Supply | Greater of VDD – 0.3 or 2.5 | — | Lesser of VDD + 0.3 or 3.6 | V | — |
| AD02 | AVSS | Module Vss Supply | Vss | — | Vss + 0.3 | V | — |
| Reference Inputs | | | | | | | |
| AD05 | VREFH | Reference Voltage High | AVSS + 2.0 | — | AVDD | V | (Note 1) |
| AD05a | | | 2.5 | — | 3.6 | V | VREFH = AVDD (Note 3) |
| AD06 | VREFL | Reference Voltage Low | AVSS | — | VREFH – 2.0 | V | (Note 1) |
| AD07 | VREF | Absolute Reference Voltage (VREFH – VREFL) | 2.0 | — | AVDD | V | (Note 3) |
| AD08 | IREF | Current Drain | — | 250 — | 400 3 | μA μA | ADC operating ADC off |
| Analog Input | | | | | | | |
| AD12 | VINH-VINL | Full-Scale Input Span | VREFL | — | VREFH | V | — |
| AD13 | VINL | Absolute VINL Input Voltage | AVSS – 0.3 | — | AVDD/2 | V | — |
| AD14 | VIN | Absolute Input Voltage | AVSS – 0.3 | — | AVDD + 0.3 | V | — |
| AD15 | — | Leakage Current | — | ±0.001 | ±0.610 | μA | VINL = AVSS = VREFL = 0V, AVDD = VREFH = 3.3V Source Impedance = 10KΩ |
| AD17 | RIN | Recommended Impedance of Analog Voltage Source | — | — | 5K | Ω | (Note 1) |
| ADC Accuracy – Measurements with External VREF+/VREF- | | | | | | | |
| AD20c | Nr | Resolution | 10 data bits | | | bits | — |
| AD21c | INL | Integral Nonlinearity | — | — | <±1 | LSb | VINL = AVSS = VREFL = 0V, AVDD = VREFH = 3.3V |
| AD22c | DNL | Differential Nonlinearity | — | — | <±1 | LSb | VINL = AVSS = VREFL = 0V, AVDD = VREFH = 3.3V (Note 2) |
| AD23c | GERR | Gain Error | — | — | <±1 | LSb | VINL = AVSS = VREFL = 0V, AVDD = VREFH = 3.3V |
| AD24n | E0FF | Offset Error | — | — | <±1 | LSb | VINL = AVSS = 0V, AVDD = 3.3V |
| AD25c | — | Monotonicity | — | — | — | — | Guaranteed |

Note 1: These parameters are not characterized or tested in manufacturing.

2: With no missing codes.

3: These parameters are characterized, but not tested in manufacturing.

4: Characterized with 1 kHz sinewave.

PIC32MX3XX/4XX

TABLE 29-34: ADC MODULE SPECIFICATIONS (CONTINUED)

| AC CHARACTERISTICS | | | Standard Operating Conditions: 2.3V to 3.6V (unless otherwise stated) Operating temperature -40°C ≤TA ≤+85°C for Industrial -40°C ≤TA ≤+105°C for V-Temp | | | | |
|--|------------------|--------------------------------|---|---------|------|-------|--|
| Param. No. | Symbol | Characteristics | Min. | Typical | Max. | Units | Conditions |
| ADC Accuracy – Measurements with Internal VREF+/VREF- | | | | | | | |
| AD20d | Nr | Resolution | 10 data bits | | | bits | (Note 3) |
| AD21d | INL | Integral Nonlinearity | — | — | <±1 | LSb | VINL = AVSS = 0V, AVDD = 2.5V to 3.6V (Note 3) |
| AD22d | DNL | Differential Nonlinearity | — | — | <±1 | LSb | VINL = AVSS = 0V, AVDD = 2.5V to 3.6V (Notes 2,3) |
| AD23d | GERR | Gain Error | — | — | <±4 | LSb | VINL = AVSS = 0V, AVDD = 2.5V to 3.6V (Note 3) |
| AD24d | E _{OFF} | Offset Error | — | — | <±2 | LSb | VINL = AVSS = 0V, AVDD = 2.5V to 3.6V (Note 3) |
| AD25d | — | Monotonicity | — | — | — | — | Guaranteed |
| Dynamic Performance | | | | | | | |
| AD31b | SINAD | Signal to Noise and Distortion | 55 | 58.5 | — | dB | (Notes 3, 4) |
| AD34b | ENOB | Effective Number of Bits | 9.0 | 9.5 | — | bits | (Notes 3, 4) |

Note 1: These parameters are not characterized or tested in manufacturing.

2: With no missing codes.

3: These parameters are characterized, but not tested in manufacturing.

4: Characterized with 1 kHz sinewave.

TABLE 29-35: 10-BIT ADC CONVERSION RATE PARAMETERS⁽²⁾

| Standard Operating Conditions: 2.3V to 3.6V (unless otherwise stated) Operating temperature -40°C ≤ TA ≤ +85°C for Industrial -40°C ≤ TA ≤ +105°C for V-Temp | | | | | |
|---|-------------|-------------------|--------|--------------|----------------------------|
| ADC Speed | TAD Minimum | Sampling Time Min | Rs Max | VDD | ADC Channels Configuration |
| 1 MIPS to 400 ksps ⁽¹⁾ | 65 ns | 132 ns | 500Ω | 3.0V to 3.6V | |
| Up to 400 ksps | 200 ns | 200 ns | 5.0 kΩ | 2.5V to 3.6V | |
| Up to 300 ksps | 200 ns | 200 ns | 5.0 kΩ | 2.5V to 3.6V | |

- Note 1:** External VREF- and VREF+ pins must be used for correct operation.
Note 2: These parameters are characterized, but not tested in manufacturing.

PIC32MX3XX/4XX

TABLE 29-36: ANALOG-TO-DIGITAL CONVERSION TIMING REQUIREMENTS

| AC CHARACTERISTICS | | | Standard Operating Conditions: 2.3V to 3.6V (unless otherwise stated) Operating temperature -40°C ≤TA ≤+85°C for Industrial -40°C ≤TA ≤+105°C for V-Temp | | | | |
|--------------------------|--------|---|---|------------------------|---------|-------|--|
| Param. No. | Symbol | Characteristics | Min. | Typical ⁽¹⁾ | Max. | Units | Conditions |
| Clock Parameters | | | | | | | |
| AD50 | TAD | Analog-to-Digital Clock Period | 65 | — | — | ns | See Table 29-35 and Note 2 |
| AD51 | TRC | Analog-to-Digital Internal RC Oscillator Period | — | 250 | — | ns | See Note 3 |
| Conversion Rate | | | | | | | |
| AD55 | TCONV | Conversion Time | — | 12 TAD | — | — | — |
| AD56 | FCNV | Throughput Rate (Sampling Speed) | — | — | 1000 | KSPS | AVDD = 3.0V to 3.6V |
| | | | — | — | 400 | KSPS | AVDD = 2.5V to 3.6V |
| AD57 | TSAMP | Sample Time | 1 TAD | — | — | — | TSAMP must be ≥ 132 ns. |
| Timing Parameters | | | | | | | |
| AD60 | TPCS | Conversion Start from Sample Trigger | — | 1.0 TAD | — | — | Auto-Convert Trigger (SSRC<2:0> = 111) not selected. See Note 3 |
| AD61 | TPSS | Sample Start from Setting Sample (SAMP) bit | 0.5 TAD | — | 1.5 TAD | — | — |
| AD62 | TCSS | Conversion Completion to Sample Start (ASAM = 1) | — | 0.5 TAD | — | — | See Note 3 |
| AD63 | TDPU | Time to Stabilize Analog Stage from Analog-to-Digital OFF to Analog-to-Digital ON | — | — | 2 | μs | See Note 3 |

Note 1: These parameters are characterized, but not tested in manufacturing.

2: Because the sample caps will eventually lose charge, clock rates below 10 kHz can affect linearity performance, especially at elevated temperatures.

3: Characterized by design but not tested.

FIGURE 29-18: ANALOG-TO-DIGITAL CONVERSION (10-BIT MODE) TIMING CHARACTERISTICS
 (CHPS<1:0> = 01, SIMSAM = 0, ASAM = 0, SSRC<2:0> = 000)

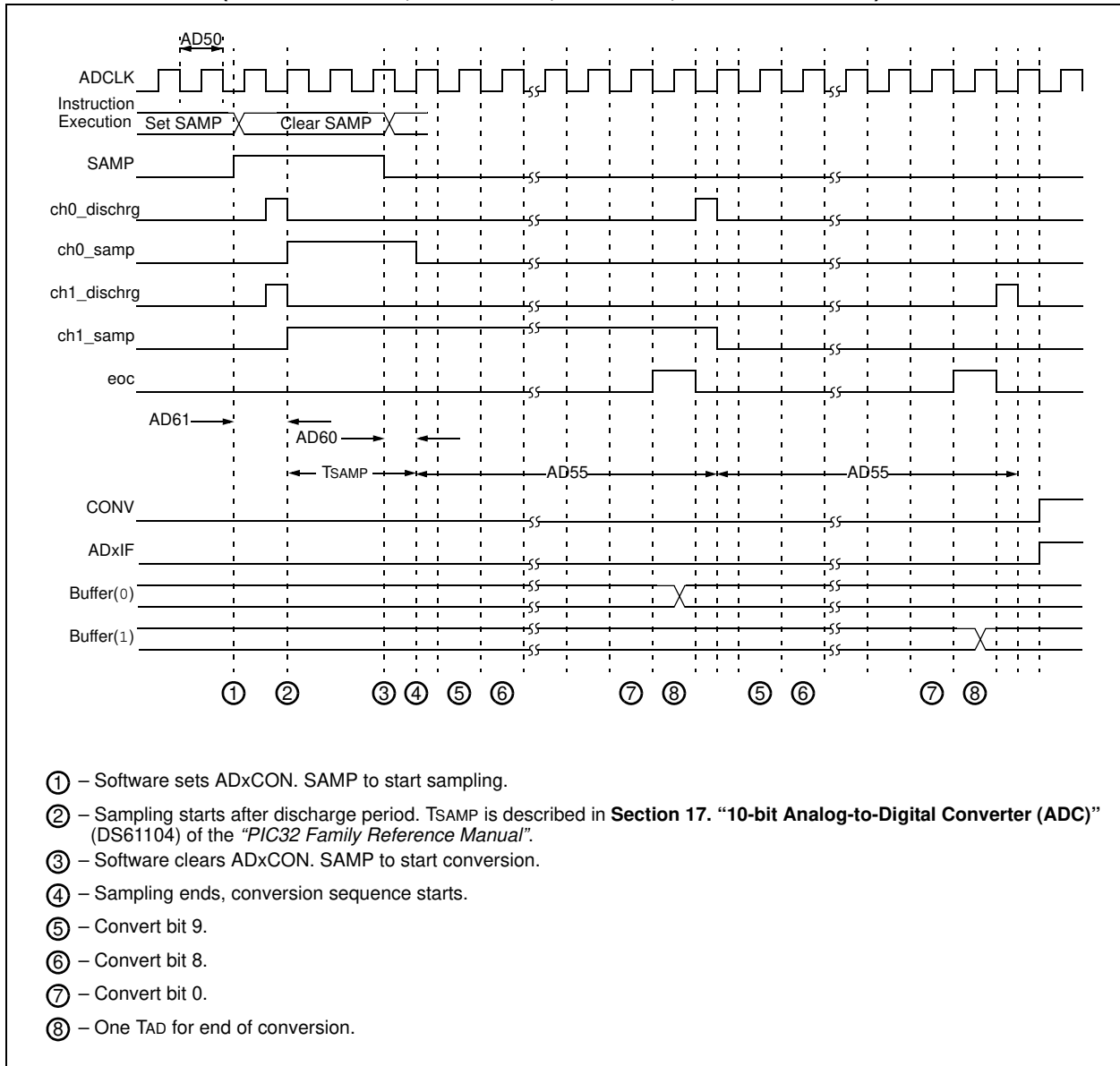

PIC32MX3XX/4XX

FIGURE 29-19: ANALOG-TO-DIGITAL CONVERSION (10-BIT MODE) TIMING CHARACTERISTICS
(CHPS<1:0> = 01, SIMSAM = 0, ASAM = 1, SSRC<2:0> = 111, SAMC<4:0> = 00001)

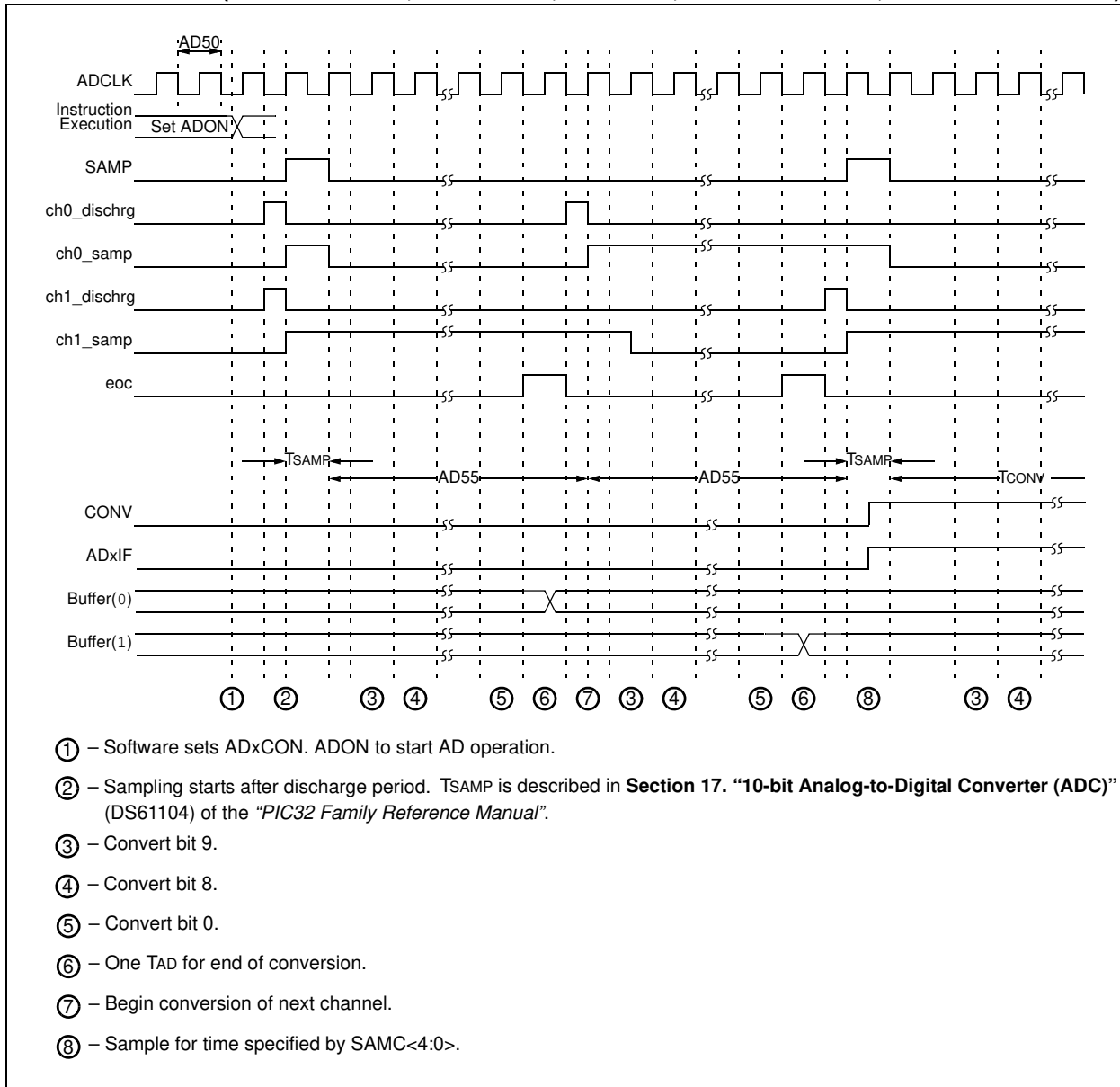

- ① – Software sets ADxCON.ADON to start AD operation.
- ② – Sampling starts after discharge period. TSAMP is described in **Section 17. “10-bit Analog-to-Digital Converter (ADC)”** (DS61104) of the “PIC32 Family Reference Manual”.
- ③ – Convert bit 9.
- ④ – Convert bit 8.
- ⑤ – Convert bit 0.
- ⑥ – One TAD for end of conversion.
- ⑦ – Begin conversion of next channel.
- ⑧ – Sample for time specified by SAMC<4:0>.

FIGURE 29-20: PARALLEL SLAVE PORT TIMING

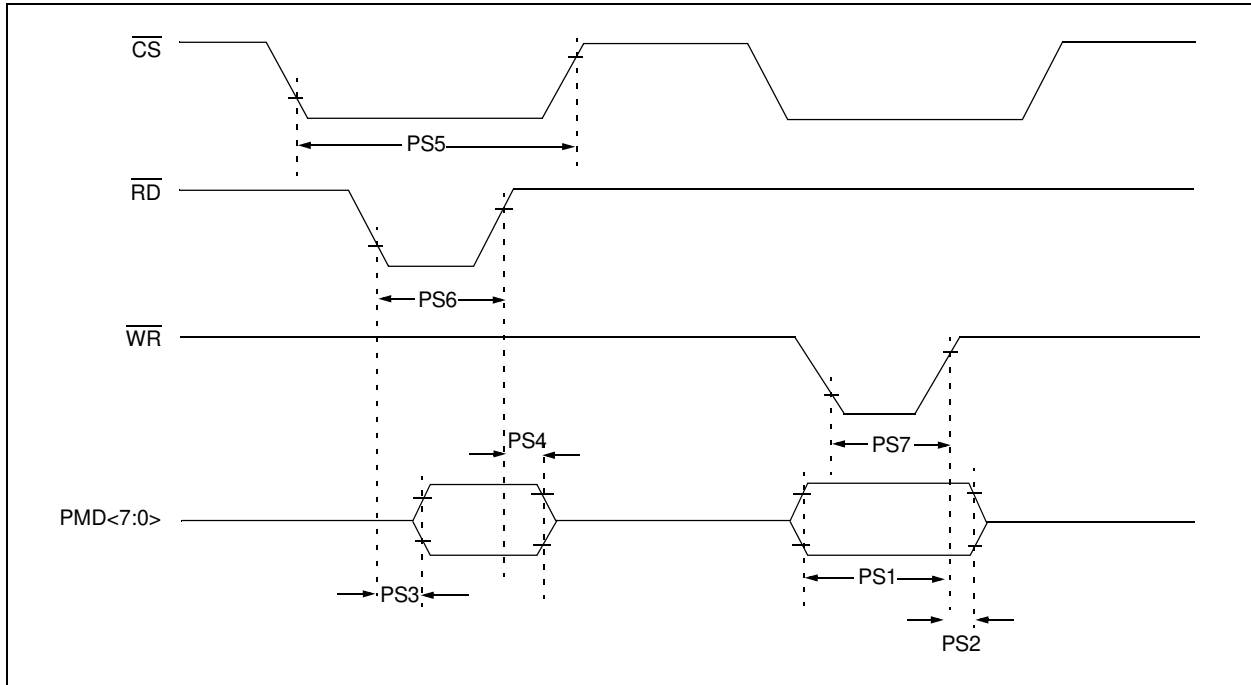

TABLE 29-37: PARALLEL SLAVE PORT REQUIREMENTS

| AC CHARACTERISTICS | | | Standard Operating Conditions: 2.3V to 3.6V (unless otherwise stated) Operating temperature $-40^{\circ}\text{C} \leq T_A \leq +85^{\circ}\text{C}$ for Industrial $-40^{\circ}\text{C} \leq T_A \leq +105^{\circ}\text{C}$ for V-Temp | | | | |
|--------------------|----------|---|---|---------|------|-------|------------|
| Param. No. | Symbol | Characteristics ⁽¹⁾ | Min. | Typical | Max. | Units | Conditions |
| PS1 | TdtV2wrH | Data In Valid before \overline{WR} or \overline{CS} Inactive (setup time) | 20 | — | — | ns | — |
| PS2 | TwrH2dtl | \overline{WR} or \overline{CS} Inactive to Data – In Invalid (hold time) | 40 | — | — | ns | — |
| PS3 | TrdL2dtV | \overline{RD} and \overline{CS} Active to Data – Out Valid | — | — | 60 | ns | — |
| PS4 | TrdH2dtl | \overline{RD} Active or \overline{CS} Inactive to Data – Out Invalid | 0 | — | 10 | ns | — |
| PS5 | Tcs | \overline{CS} Active Time | TPB + 40 | — | — | ns | — |
| PS6 | TWR | \overline{WR} Active Time | TPB + 25 | — | — | ns | — |
| PS7 | TRD | \overline{RD} Active Time | TPB + 25 | — | — | ns | — |

Note 1: These parameters are characterized, but not tested in manufacturing.

PIC32MX3XX/4XX

FIGURE 29-21: PARALLEL MASTER PORT READ TIMING DIAGRAM

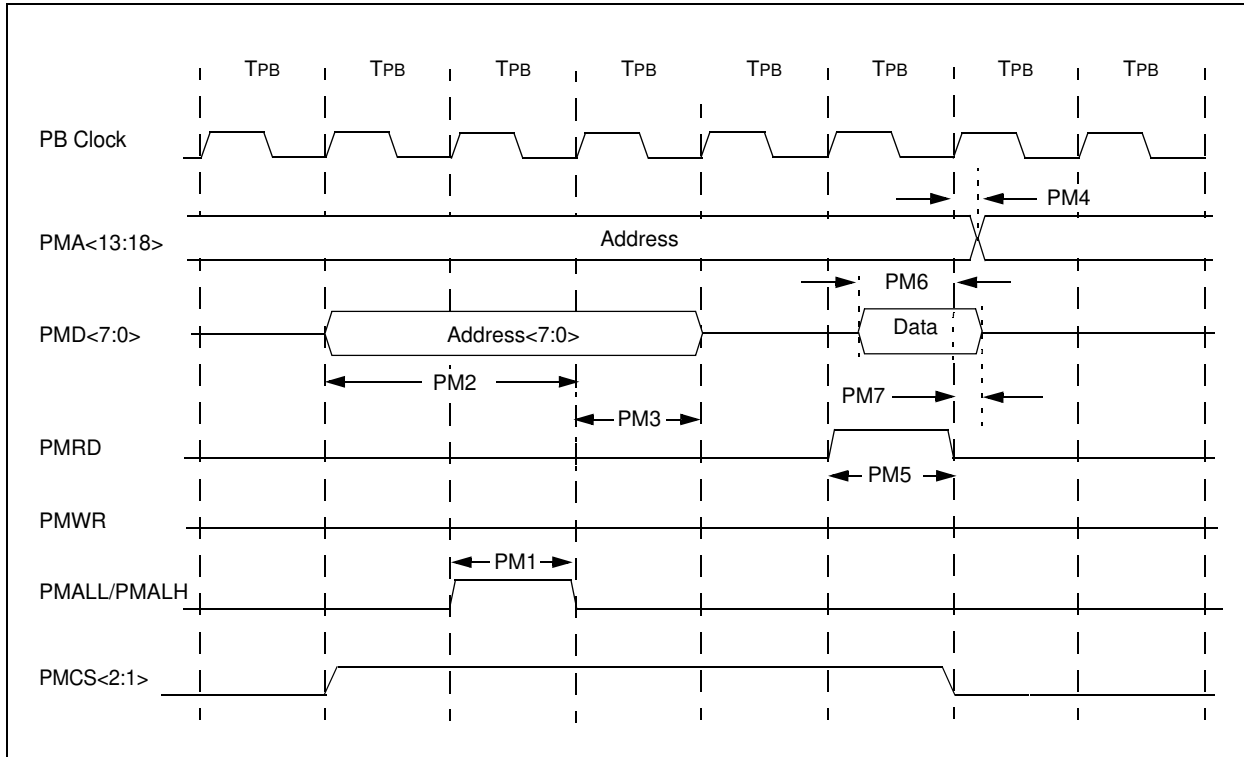

TABLE 29-38: PARALLEL MASTER PORT READ TIMING REQUIREMENTS

| AC CHARACTERISTICS | | | Standard Operating Conditions: 2.3V to 3.6V (unless otherwise stated) Operating temperature $-40^{\circ}\text{C} \leq T_A \leq +85^{\circ}\text{C}$ for Industrial $-40^{\circ}\text{C} \leq T_A \leq +105^{\circ}\text{C}$ for V-Temp | | | | |
|--------------------|---------|--|---|---------|------|-------|------------|
| Param. No. | Symbol | Characteristics ⁽¹⁾ | Min. | Typical | Max. | Units | Conditions |
| PM1 | TLAT | PMALL/PMALH Pulse Width | — | 1 TPB | — | — | — |
| PM2 | TDSU | Address Out Valid to PMALL/PMALH Invalid (address setup time) | — | 2 TPB | — | — | — |
| PM3 | TADHOLD | PMALL/PMALH Invalid to Address Out Invalid (address hold time) | — | 1 TPB | — | — | — |
| PM4 | TAHOLD | PMRD Inactive to Address Out Invalid (address hold time) | 5 | — | — | ns | — |
| PM5 | TRD | PMRD Pulse Width | — | 1 TPB | — | — | — |
| PM6 | TDSU | PMRD or PMENB Active to Data In Valid (data setup time) | 15 | — | — | ns | — |
| PM7 | TDHOLD | PMRD or PMENB Inactive to Data In Invalid (data hold time) | — | 80 | — | ns | — |

Note 1: These parameters are characterized, but not tested in manufacturing.

FIGURE 29-22: PARALLEL MASTER PORT WRITE TIMING DIAGRAM

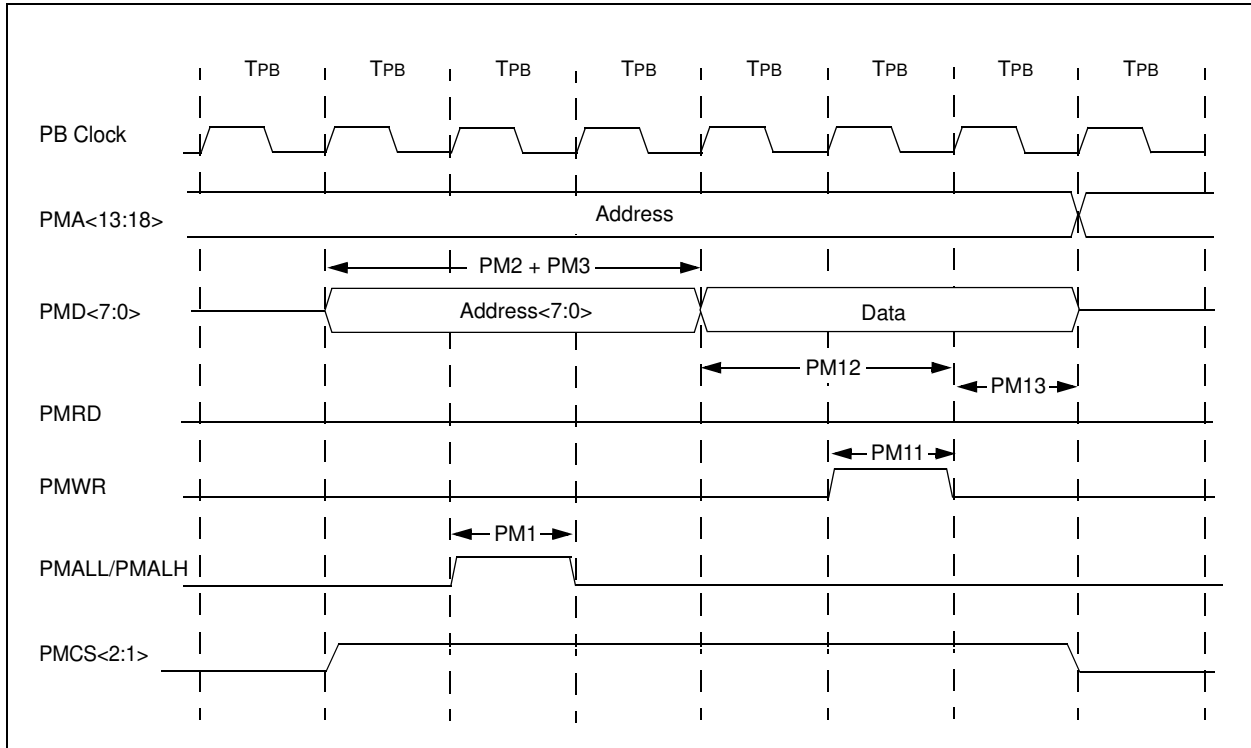

TABLE 29-39: PARALLEL MASTER PORT WRITE TIMING REQUIREMENTS

| AC CHARACTERISTICS | | | Standard Operating Conditions: 2.3V to 3.6V (unless otherwise stated) Operating temperature -40°C ≤ TA ≤ +85°C for Industrial -40°C ≤ TA ≤ +105°C for V-Temp | | | | |
|--------------------|---------|---|---|---------|------|-------|------------|
| Param. No. | Symbol | Characteristics ⁽¹⁾ | Min. | Typical | Max. | Units | Conditions |
| PM11 | TWR | PMWR Pulse Width | — | 1 TPB | — | — | — |
| PM12 | TDVSU | Data Out Valid before PMWR or PMENB goes Inactive (data setup time) | — | 2 TPB | — | — | — |
| PM13 | TDVHOLD | PMWR or PMEMB Invalid to Data Out Invalid (data hold time) | — | 1 TPB | — | — | — |

Note 1: These parameters are characterized, but not tested in manufacturing.

PIC32MX3XX/4XX

TABLE 29-40: OTG ELECTRICAL SPECIFICATIONS

| AC CHARACTERISTICS | | | Standard Operating Conditions: 2.3V to 3.6V (unless otherwise stated) Operating temperature -40°C ≤TA ≤+85°C for Industrial -40°C ≤TA ≤+105°C for V-Temp | | | | |
|--------------------|--------|-----------------------------------|---|-----|------|-------|---|
| Param. No. | Symbol | Characteristics ⁽¹⁾ | Min. | Typ | Max. | Units | Conditions |
| USB313 | VUSB | USB Voltage | 3.0 | — | 3.6 | V | Voltage on VUSB must be in this range for proper USB operation. |
| USB315 | VILUSB | Input Low Voltage for USB Buffer | — | — | 0.8 | V | — |
| USB316 | VIHUSB | Input High Voltage for USB Buffer | 2.0 | — | — | V | — |
| USB318 | VDIFS | Differential Input Sensitivity | — | — | 0.2 | V | The difference between D+ and D- must exceed this value while VCM is met. |
| USB319 | VCM | Differential Common Mode Range | 0.8 | — | 2.5 | V | — |
| USB320 | ZOUT | Driver Output Impedance | 28.0 | — | 44.0 | Ω | — |
| USB321 | VOL | Voltage Output Low | 0.0 | — | 0.3 | V | 1.5 kΩ load connected to 3.6V. |
| USB322 | VOH | Voltage Output High | 2.8 | — | 3.6 | V | 1.5 kΩ load connected to ground. |

Note 1: These parameters are characterized, but not tested in manufacturing.

FIGURE 29-23: EJTAG TIMING CHARACTERISTICS

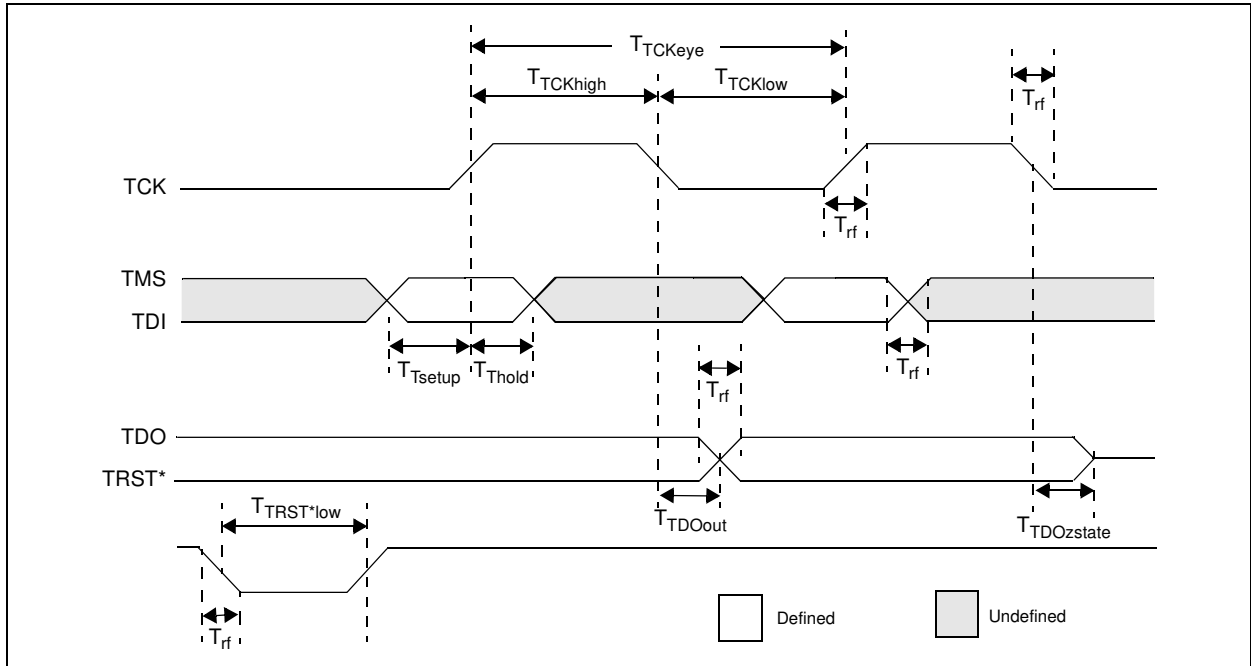

TABLE 29-41: EJTAG TIMING REQUIREMENTS

| AC CHARACTERISTICS | | | Standard Operating Conditions: 2.3V to 3.6V (unless otherwise stated) Operating temperature $-40^{\circ}\text{C} \leq T_A \leq +85^{\circ}\text{C}$ for Industrial $-40^{\circ}\text{C} \leq T_A \leq +105^{\circ}\text{C}$ for V-Temp | | | |
|--------------------|-----------------|--|---|------|-------|------------|
| Param. No. | Symbol | Description ⁽¹⁾ | Min. | Max. | Units | Conditions |
| EJ1 | T_{TCKCYC} | TCK Cycle Time | 25 | — | ns | — |
| EJ2 | $T_{TCKHIGH}$ | TCK High Time | 10 | — | ns | — |
| EJ3 | T_{TCKLOW} | TCK Low Time | 10 | — | ns | — |
| EJ4 | T_{TSETUP} | TAP Signals Setup Time Before Rising TCK | 5 | — | ns | — |
| EJ5 | T_{THOLD} | TAP Signals Hold Time After Rising TCK | 3 | — | ns | — |
| EJ6 | T_{TDOOUT} | TDO Output Delay Time from Falling TCK | — | 5 | ns | — |
| EJ7 | $T_{TDOZSTATE}$ | TDO 3-State Delay Time from Falling TCK | — | 5 | ns | — |
| EJ8 | $T_{TRSTLOW}$ | TRST Low Time | 25 | — | ns | — |
| EJ9 | T_{RF} | TAP Signals Rise/Fall Time, All Input and Output | — | — | ns | — |

Note 1: These parameters are characterized, but not tested in manufacturing.

PIC32MX3XX/4XX

NOTES:

30.0 PACKAGING INFORMATION

30.1 Package Marking Information

64-Lead TQFP (10x10x1 mm)

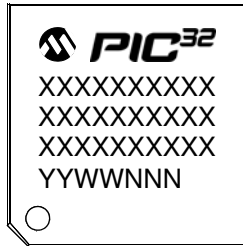

Example

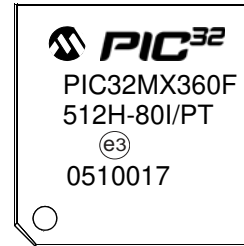

100-Lead TQFP (12x12x1 mm)



Example



64-Lead QFN (9x9x0.9 mm)



Example



121-Lead XBGA (10x10x1.1 mm)



Example



| | | |
|----------------|--------|--|
| Legend: | XX...X | Customer-specific information |
| | Y | Year code (last digit of calendar year) |
| | YY | Year code (last 2 digits of calendar year) |
| | WW | Week code (week of January 1 is week '01') |
| | NNN | Alphanumeric traceability code |
| | * | Pb-free JEDEC designator for Matte Tin (Sn) |
| | | This package is Pb-free. The Pb-free JEDEC designator (e3) can be found on the outer packaging for this package. |

Note: In the event the full Microchip part number cannot be marked on one line, it will be carried over to the next line, thus limiting the number of available characters for customer-specific information.

PIC32MX3XX/4XX

30.2 Package Details

The following sections give the technical details of the packages.

64-Lead Plastic Thin Quad Flatpack (PT) – 10x10x1 mm Body, 2.00 mm [TQFP]

Note: For the most current package drawings, please see the Microchip Packaging Specification located at <http://www.microchip.com/packaging>

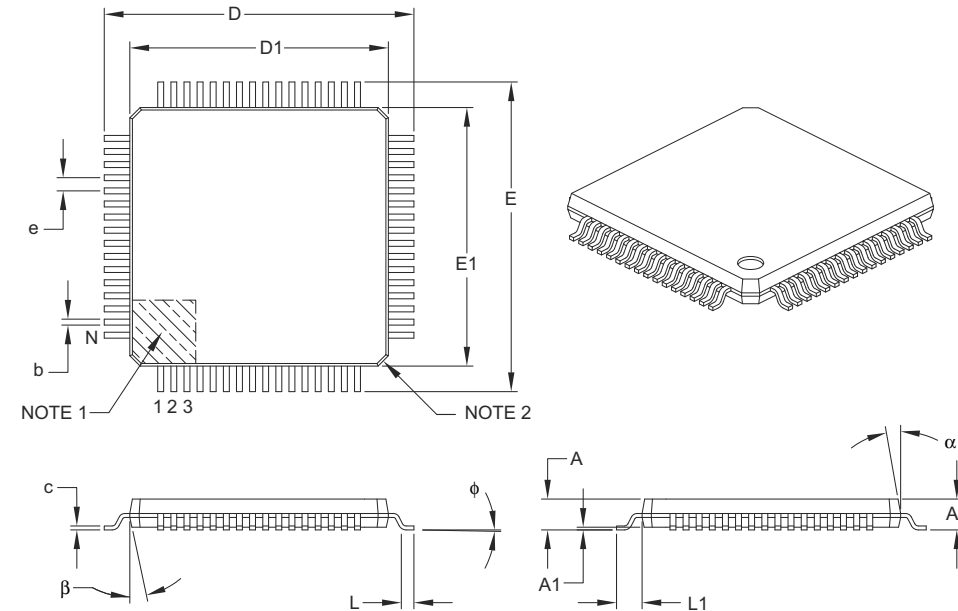

| Units | | MILLIMETERS | | |
|--------------------------|----------|-------------|------|------|
| | | MIN | NOM | MAX |
| Number of Leads | N | 64 | | |
| Lead Pitch | e | 0.50 BSC | | |
| Overall Height | A | – | – | 1.20 |
| Molded Package Thickness | A2 | 0.95 | 1.00 | 1.05 |
| Standoff | A1 | 0.05 | – | 0.15 |
| Foot Length | L | 0.45 | 0.60 | 0.75 |
| Footprint | L1 | 1.00 REF | | |
| Foot Angle | ϕ | 0° | 3.5° | 7° |
| Overall Width | E | 12.00 BSC | | |
| Overall Length | D | 12.00 BSC | | |
| Molded Package Width | E1 | 10.00 BSC | | |
| Molded Package Length | D1 | 10.00 BSC | | |
| Lead Thickness | c | 0.09 | – | 0.20 |
| Lead Width | b | 0.17 | 0.22 | 0.27 |
| Mold Draft Angle Top | α | 11° | 12° | 13° |
| Mold Draft Angle Bottom | β | 11° | 12° | 13° |

Notes:

- Pin 1 visual index feature may vary, but must be located within the hatched area.
- Chamfers at corners are optional; size may vary.
- Dimensions D1 and E1 do not include mold flash or protrusions. Mold flash or protrusions shall not exceed 0.25 mm per side.
- Dimensioning and tolerancing per ASME Y14.5M.

BSC: Basic Dimension. Theoretically exact value shown without tolerances.

REF: Reference Dimension, usually without tolerance, for information purposes only.

Microchip Technology Drawing C04-085B

PIC32MX3XX/4XX

64-Lead Plastic Thin Quad Flatpack (PT) 10x10x1 mm Body, 2.00 mm Footprint [TQFP]

Note: For the most current package drawings, please see the Microchip Packaging Specification located at <http://www.microchip.com/packaging>

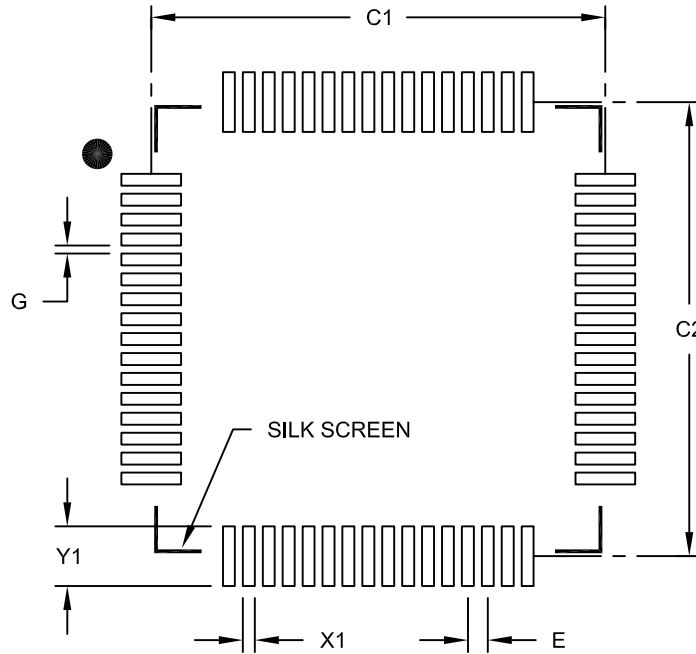

RECOMMENDED LAND PATTERN

| Dimension Limits | Units | MILLIMETERS | | |
|--------------------------|-------|-------------|-------|------|
| | | MIN | NOM | MAX |
| Contact Pitch | E | 0.50 BSC | | |
| Contact Pad Spacing | C1 | | 11.40 | |
| Contact Pad Spacing | C2 | | 11.40 | |
| Contact Pad Width (X64) | X1 | | | 0.30 |
| Contact Pad Length (X64) | Y1 | | | 1.50 |
| Distance Between Pads | G | 0.20 | | |

Notes:

1. Dimensioning and tolerancing per ASME Y14.5M

BSC: Basic Dimension. Theoretically exact value shown without tolerances.

Microchip Technology Drawing No. C04-2085B

PIC32MX3XX/4XX

64-Lead Plastic Quad Flat, No Lead Package (MR) – 9x9x0.9 mm Body [QFN] With 7.15 x 7.15 Exposed Pad [QFN]

Note: For the most current package drawings, please see the Microchip Packaging Specification located at <http://www.microchip.com/packaging>

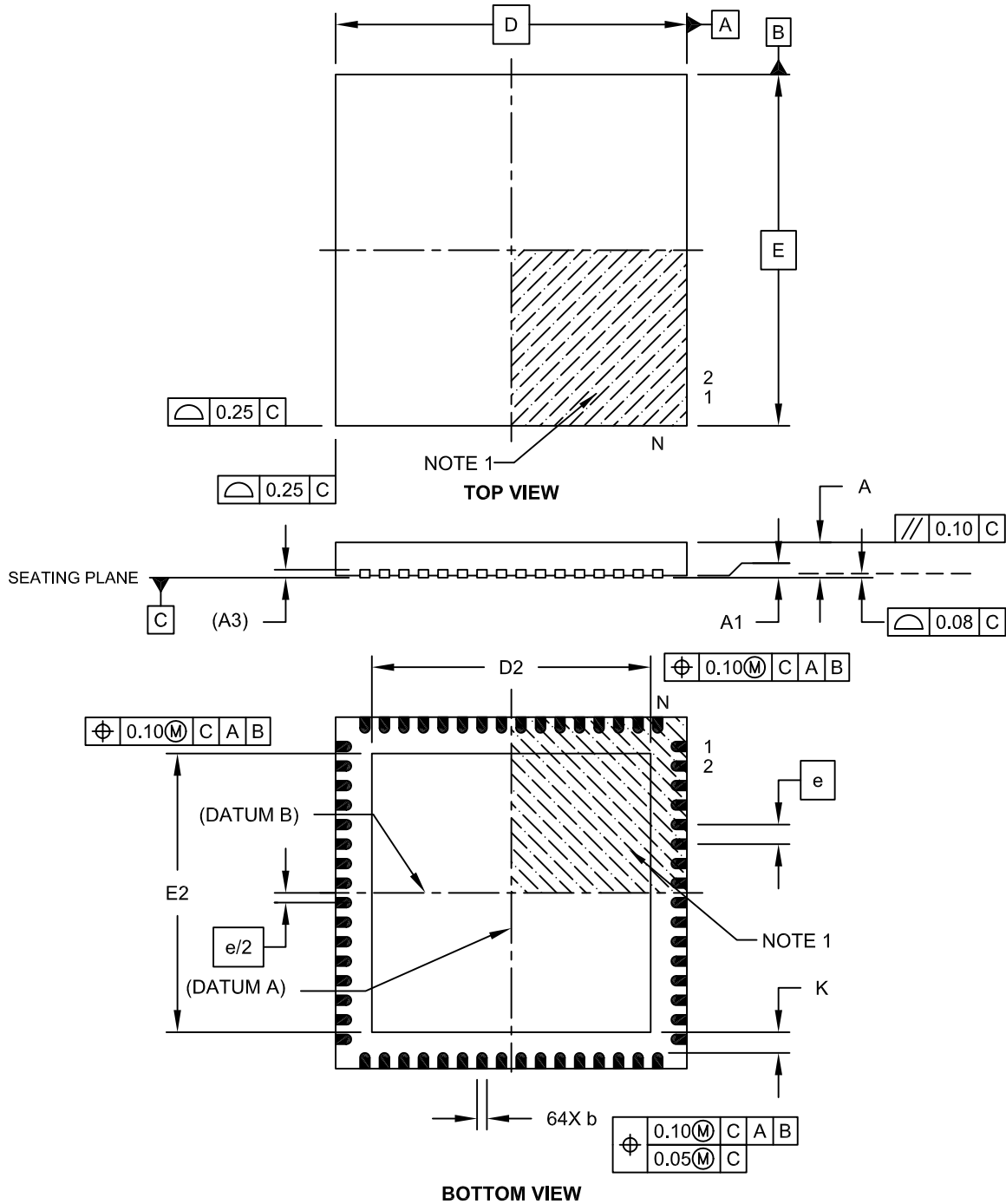

Microchip Technology Drawing C04-149C Sheet 1 of 2

PIC32MX3XX/4XX

64-Lead Plastic Quad Flat, No Lead Package (MR) – 9x9x0.9 mm Body [QFN] With 7.15 x 7.15 Exposed Pad [QFN]

Note: For the most current package drawings, please see the Microchip Packaging Specification located at <http://www.microchip.com/packaging>

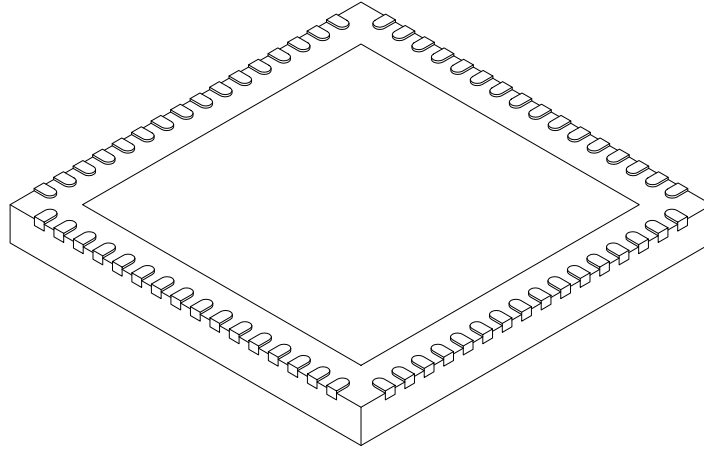

| Dimension Limits | Units | MILLIMETERS | | |
|------------------------|-------|-------------|------|------|
| | | MIN | NOM | MAX |
| Number of Pins | N | 64 | | |
| Pitch | e | 0.50 BSC | | |
| Overall Height | A | 0.80 | 0.90 | 1.00 |
| Standoff | A1 | 0.00 | 0.02 | 0.05 |
| Contact Thickness | A3 | 0.20 REF | | |
| Overall Width | E | 9.00 BSC | | |
| Exposed Pad Width | E2 | 7.05 | 7.15 | 7.50 |
| Overall Length | D | 9.00 BSC | | |
| Exposed Pad Length | D2 | 7.05 | 7.15 | 7.50 |
| Contact Width | b | 0.18 | 0.25 | 0.30 |
| Contact Length | L | 0.30 | 0.40 | 0.50 |
| Contact-to-Exposed Pad | K | 0.20 | - | - |

Notes:

1. Pin 1 visual index feature may vary, but must be located within the hatched area.
2. Package is saw singulated.
3. Dimensioning and tolerancing per ASME Y14.5M.

BSC: Basic Dimension. Theoretically exact value shown without tolerances.

REF: Reference Dimension, usually without tolerance, for information purposes only.

Microchip Technology Drawing C04-149C Sheet 2 of 2

PIC32MX3XX/4XX

64-Lead Plastic Quad Flat, No Lead Package (MR) – 9x9x0.9 mm Body [QFN]
With 0.40 mm Contact Length

Note: For the most current package drawings, please see the Microchip Packaging Specification located at <http://www.microchip.com/packaging>

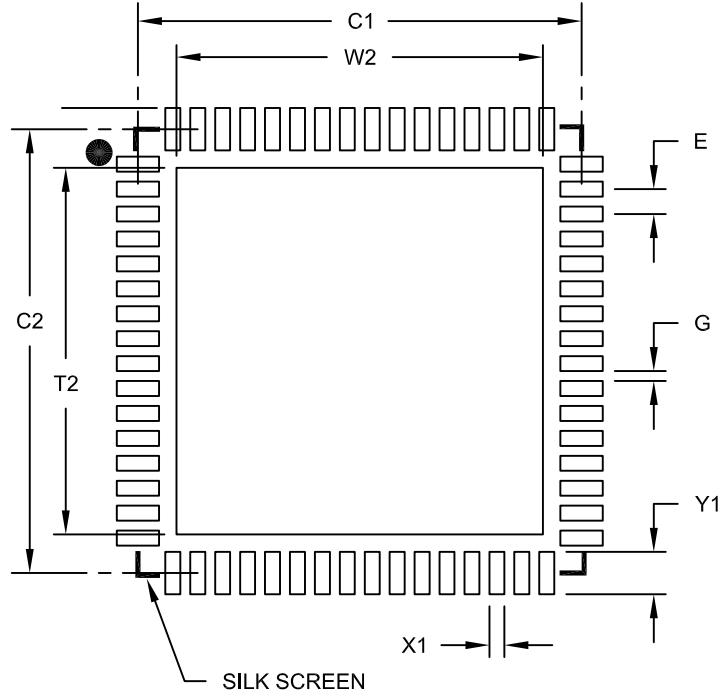

RECOMMENDED LAND PATTERN

| | | Units | MILLIMETERS | | |
|----------------------------|----|-------|-------------|------|------|
| Dimension Limits | | | MIN | NOM | MAX |
| Contact Pitch | E | | 0.50 BSC | | |
| Optional Center Pad Width | W2 | | | | 7.35 |
| Optional Center Pad Length | T2 | | | | 7.35 |
| Contact Pad Spacing | C1 | | | 8.90 | |
| Contact Pad Spacing | C2 | | | 8.90 | |
| Contact Pad Width (X64) | X1 | | | | 0.30 |
| Contact Pad Length (X64) | Y1 | | | | 0.85 |
| Distance Between Pads | G | 0.20 | | | |

Notes:

1. Dimensioning and tolerancing per ASME Y14.5M

BSC: Basic Dimension. Theoretically exact value shown without tolerances.

Microchip Technology Drawing No. C04-2149A

PIC32MX3XX/4XX

100-Lead Plastic Thin Quad Flatpack (PT) – 12x12x1 mm Body, 2.00 mm [TQFP]

Note: For the most current package drawings, please see the Microchip Packaging Specification located at <http://www.microchip.com/packaging>

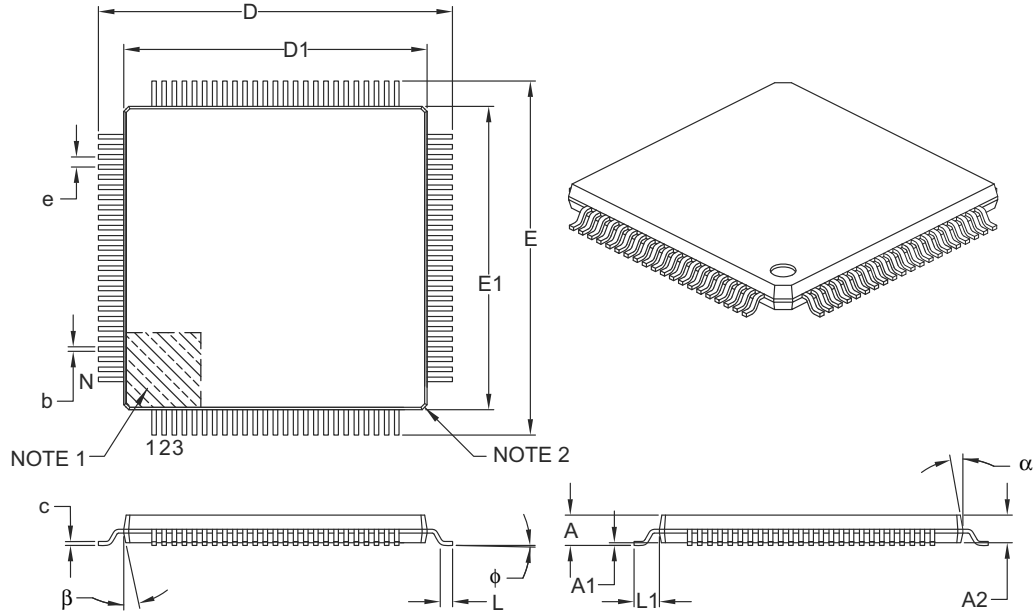

| | | Units | MILLIMETERS | | |
|--------------------------|----|-------|-------------|------|------|
| Dimension Limits | | | MIN | NOM | MAX |
| Number of Leads | N | | 100 | | |
| Lead Pitch | e | | 0.40 BSC | | |
| Overall Height | A | | – | – | 1.20 |
| Molded Package Thickness | A2 | | 0.95 | 1.00 | 1.05 |
| Standoff | A1 | | 0.05 | – | 0.15 |
| Foot Length | L | | 0.45 | 0.60 | 0.75 |
| Footprint | L1 | | 1.00 REF | | |
| Foot Angle | φ | | 0° | 3.5° | 7° |
| Overall Width | E | | 14.00 BSC | | |
| Overall Length | D | | 14.00 BSC | | |
| Molded Package Width | E1 | | 12.00 BSC | | |
| Molded Package Length | D1 | | 12.00 BSC | | |
| Lead Thickness | c | | 0.09 | – | 0.20 |
| Lead Width | b | | 0.13 | 0.18 | 0.23 |
| Mold Draft Angle Top | α | | 11° | 12° | 13° |
| Mold Draft Angle Bottom | β | | 11° | 12° | 13° |

Notes:

- Pin 1 visual index feature may vary, but must be located within the hatched area.
- Chamfers at corners are optional; size may vary.
- Dimensions D1 and E1 do not include mold flash or protrusions. Mold flash or protrusions shall not exceed 0.25 mm per side.
- Dimensioning and tolerancing per ASME Y14.5M.

BSC: Basic Dimension. Theoretically exact value shown without tolerances.

REF: Reference Dimension, usually without tolerance, for information purposes only.

Microchip Technology Drawing C04-100B

PIC32MX3XX/4XX

100-Lead Plastic Thin Quad Flatpack (PT)-12x12x1mm Body, 2.00 mm Footprint [TQFP]

Note: For the most current package drawings, please see the Microchip Packaging Specification located at <http://www.microchip.com/packaging>

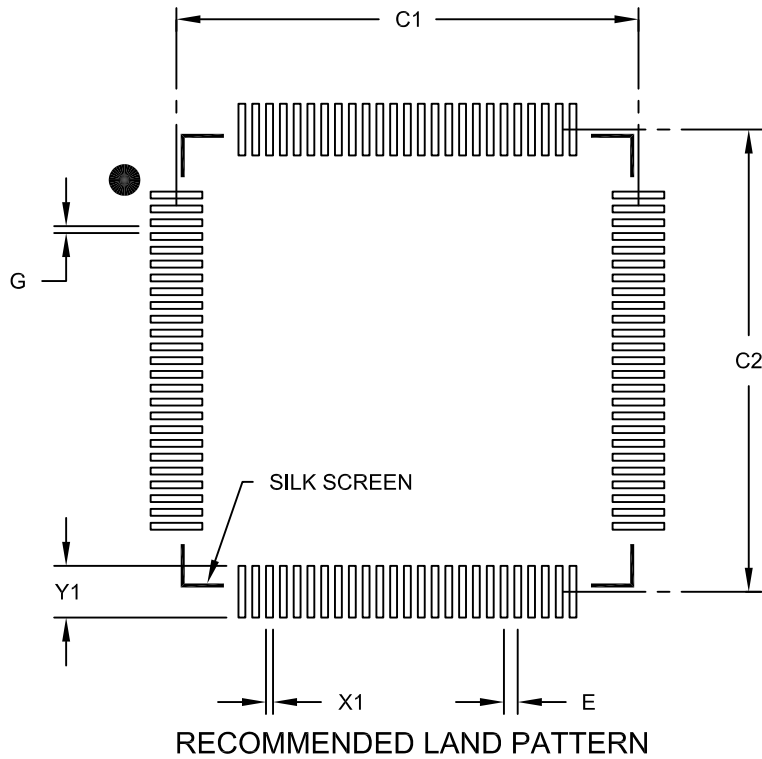

| Dimension Limits | Units | MILLIMETERS | | |
|---------------------------|-------|-------------|-------|------|
| | | MIN | NOM | MAX |
| Contact Pitch | E | 0,40 BSC | | |
| Contact Pad Spacing | C1 | | 13,40 | |
| Contact Pad Spacing | C2 | | 13,40 | |
| Contact Pad Width (X100) | X1 | | | 0,20 |
| Contact Pad Length (X100) | Y1 | | | 1,50 |
| Distance Between Pads | G | 0,20 | | |

Notes:

1. Dimensioning and tolerancing per ASME Y14.5M

BSC: Basic Dimension. Theoretically exact value shown without tolerances.

Microchip Technology Drawing No. C04-2100B

PIC32MX3XX/4XX

121-Lead Plastic Thin Profile Ball Grid Array (BG) - 10x10x1.10 mm Body [XBGA]

Note: For the most current package drawings, please see the Microchip Packaging Specification located at <http://www.microchip.com/packaging>

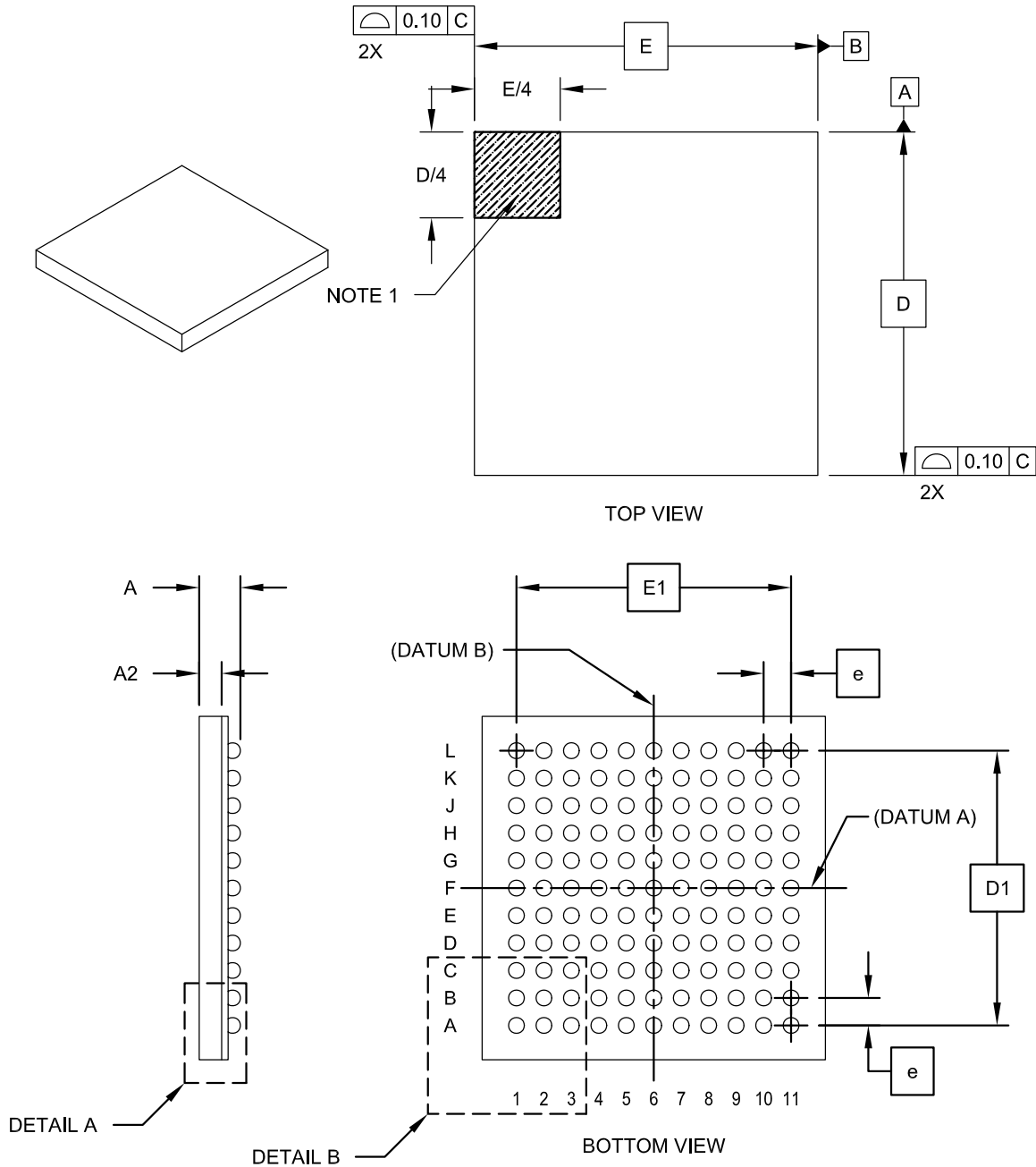

Microchip Technology Drawing C04-148B Sheet 1 of 2

PIC32MX3XX/4XX

121-Lead Plastic Thin Profile Ball Grid Array (BG) - 10x10x1.10 mm Body [XBGA]

Note: For the most current package drawings, please see the Microchip Packaging Specification located at <http://www.microchip.com/packaging>

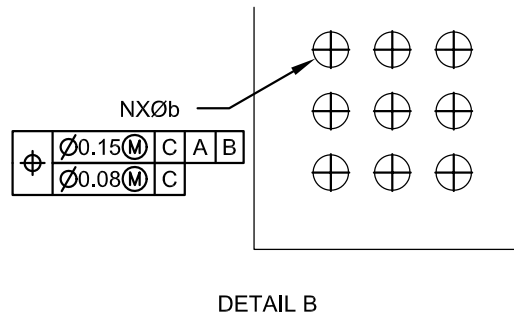
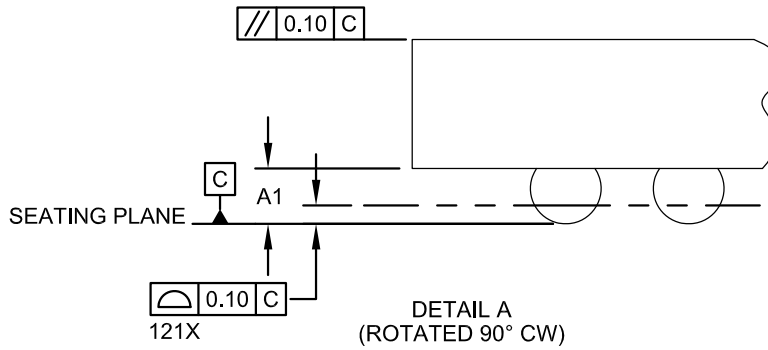

| Dimension Limits | Units | MILLIMETERS | | |
|--------------------------|-------|-------------|------|------|
| | | MIN | NOM | MAX |
| Number of Contacts | N | 121 | | |
| Contact Pitch | e | 0.80 BSC | | |
| Overall Height | A | 1.00 | 1.10 | 1.20 |
| Standoff | A1 | 0.25 | 0.30 | 0.35 |
| Molded Package Thickness | A2 | 0.55 | 0.60 | 0.65 |
| Overall Width | E | 10.00 BSC | | |
| Array Width | E1 | 8.00 BSC | | |
| Overall Length | D | 10.00 BSC | | |
| Array Length | D1 | 8.00 BSC | | |
| Contact Diameter | b | 0.40 TYP | | |

Notes:

- Pin 1 visual index feature may vary, but must be located within the hatched area.
- Dimensioning and tolerancing per ASME Y14.5M.
BSC: Basic Dimension. Theoretically exact value shown without tolerances.
REF: Reference Dimension, usually without tolerance, for information purposes only.
- The outer rows and columns of balls are located with respect to datums A and B.

Microchip Technology Drawing C04-148 Rev B Sheet 2 of 2

121-Lead Plastic Thin Profile Ball Grid Array (BG) - 10x10x1.10 mm Body [XBGA]

Note: For the most current package drawings, please see the Microchip Packaging Specification located at <http://www.microchip.com/packaging>

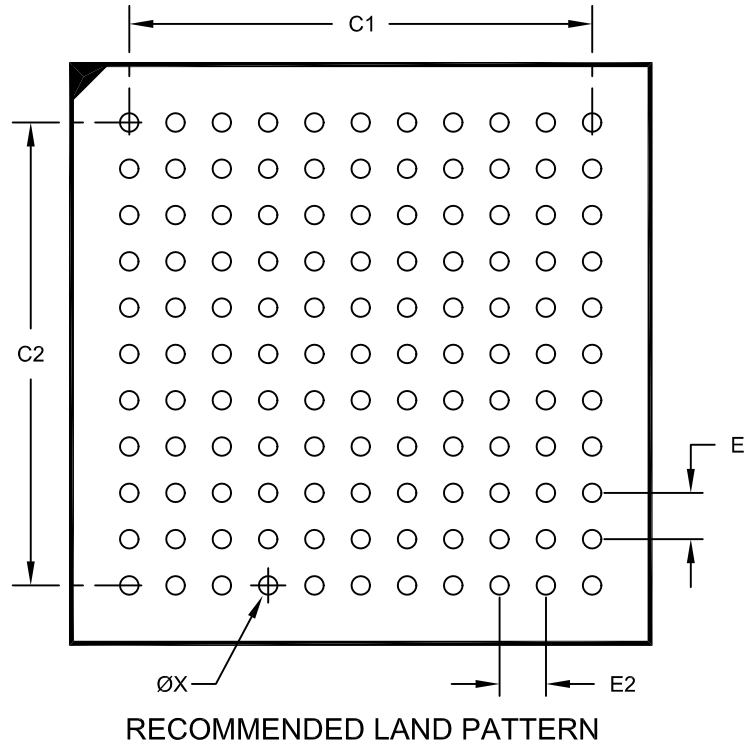

| Dimension Limits | Units | MILLIMETERS | | |
|-----------------------------|-------|-------------|------|------|
| | | MIN | NOM | MAX |
| Contact Pitch | E1 | 0.80 BSC | | |
| Contact Pitch | E2 | 0.80 BSC | | |
| Contact Pad Spacing | C1 | | 8.00 | |
| Contact Pad Spacing | C2 | | 8.00 | |
| Contact Pad Diameter (X121) | X | | | 0.32 |

Notes:

1. Dimensioning and tolerancing per ASME Y14.5M

BSC: Basic Dimension. Theoretically exact value shown without tolerances.

Microchip Technology Drawing No. C04-2148B

PIC32MX3XX/4XX

NOTES:

APPENDIX A: REVISION HISTORY

Revision E (July 2008)

- Updated the PIC32MX340F128H features in Table 1 to include 4 programmable DMA channels.

Revision F (June 2009)

This revision includes minor typographical and formatting changes throughout the data sheet text.

Global changes include:

- Changed all instances of OSC1 to OSC1 and OSC0 to OSC2
- Changed all instances of VDDCORE and VDDCORE/VCAP to VCAP/VDDCORE
- Deleted registers in most sections, refer to the related section of the *"PIC32 Family Reference Manual"* (DS61132).

The other changes are referenced by their respective section in the following table.

TABLE A-1: MAJOR SECTION UPDATES

| Section Name | Update Description |
|--|---|
| "High-Performance, General Purpose and USB 32-bit Flash Microcontrollers" | <p>Added a "Packages" column to Table 1 and Table 2.</p> <p>Corrected all pin diagrams to update the following pin names.</p> <ul style="list-style-type: none"> Changed PGC1/EMUC1 to PGEC1 Changed PGD1/EMUD1 to PGED1 Changed PGC2/EMUC2 to PGEC2 Changed PGD2/EMUD2 to PGED2 <p>Shaded appropriate pins in each diagram to indicate which pins are 5V tolerant.</p> <p>Added 64-Lead QFN package pin diagrams, one for General Purpose and one for USB.</p> |
| Section 1.0 "Device Overview" | Reconstructed Figure 1-1 to include Timers, ADC and RTCC in the block diagram. |
| Section 2.0 "Guidelines for Getting Started with 32-bit Microcontrollers" | <p>Added a new section to the data sheet that provides the following information:</p> <ul style="list-style-type: none"> Basic Connection Requirements Capacitors Master Clear Pin ICSP™ Pins External Oscillator Pins Configuration of Analog and Digital Pins Unused I/Os |
| Section 4.0 "Memory Organization" | <p>Updated the memory maps, Figure 4-1 through Figure 4-6.</p> <p>All summary peripheral register maps were relocated to Section 4.0 "Memory Organization".</p> |
| Section 7.0 "Interrupt Controller" | Removed the "Address" column from Table 7-1. |
| Section 12.0 "I/O Ports" | Added a second paragraph in Section 12.1.3 "Analog Inputs" to clarify that all pins that share ANx functions are analog by default, because the AD1PCFG register has a default value of 0x0000. |

PIC32MX3XX/4XX

TABLE A-1: MAJOR SECTION UPDATES (CONTINUED)

| Section Name | Update Description |
|--|---|
| Section 26.0 “Special Features” | <p>Modified bit names and locations in Register 26-5 “DEVID: Device and Revision ID Register”.</p> <p>Replaced “TSTARTUP” with “TPU”, and “64-ms nominal delay” with “TPWRT”, in Section 26.3.1 “On-Chip Regulator and POR”.</p> <p>The information that appeared in the Watchdog Timer and the Programming and Diagnostics sections of 61143E version of this data sheet has been incorporated into the Special Features section:</p> <ul style="list-style-type: none">• Section 26.2 “Watchdog Timer (WDT)”• Section 26.4 “Programming and Diagnostics” |
| Section 29.0 “Electrical Characteristics” | <p>Added the 64-Lead QFN package to Table 29-3.</p> <p>Updated data in Table 29-5.</p> <p>Updated data in Table 29-7.</p> <p>Updated data in Table 29-4, Table 29-5, Table 29-7 and Table 29-8.</p> <p>Updated data in Table 29-11.</p> <p>Added OS42 parameter to Table 29-17.</p> <p>Replaced Table 29-23.</p> <p>Replaced Table 29-24.</p> <p>Replaced Table 29-25.</p> <p>Updated Table 29-36.</p> |
| Section 30.0 “Packaging Information” | <p>Added 64-Lead QFN package marking information to Section 30.1 “Package Marking Information”.</p> <p>Added the 64-Lead QFN (MR) package drawing and land pattern to Section 30.2 “Package Details”.</p> |
| “Product Identification System” | <p>Added the MR package designator for the 64-Lead (9x9x0.9) QFN.</p> |

Revision G (April 2010)

The revision includes the following global update:

- Added Note 2 to the shaded table that appears at the beginning of each chapter. This new note provides information regarding the availability of registers and their associated bits.

This revision also includes minor typographical and formatting changes throughout the data sheet text. Major updates are referenced by their respective section in the following table.

TABLE A-2: MAJOR SECTION UPDATES

| Section Name | Update Description |
|--|---|
| “High-Performance, General Purpose and USB 32-bit Flash Microcontrollers” | <p>Updated the crystal oscillator range to 3 MHz to 25 MHz (see Peripheral Features:)</p> <p>Added the 121-pin Ball Grid Array (XBGA) pin diagram.</p> <p>Updated Table 1: “PIC32MX General Purpose – Features” and Table 2: “PIC32MX USB – Features”</p> <p>Added the following tables:</p> <ul style="list-style-type: none"> - Table 3: “Pin Names: PIC32MX320F128L, PIC32MX340F128L, and PIC32MX360F128L, and PIC32MX360F512L Devices”, - Table 4: “Pin Names: PIC32MX440F128L, PIC32MX460F256L and PIC32MX460F512L Devices” <p>Updated the following pins as 5V tolerant:</p> <ul style="list-style-type: none"> - 64-pin QFN (USB): Pin 34 (VBUS), Pin 36 (D-/RG3) and Pin 37 (D+/RG2) - 64-pin TQFP (USB): Pin 34 (Vbus), Pin 36 (D-/RG3), Pin 37 (D+/RG2) and Pin 42 (IC1/RTCC/INT1/RD8) - 100-pin TQFP (USB): Pin 54 (VBUS), Pin 56 (D-/RG3) and Pin 57 (D+/RG2) |
| Section 1.0 “Device Overview” | Updated the Pinout I/O Descriptions table to include the device pin numbers (see Table 1-1) |
| Section 2.0 “Guidelines for Getting Started with 32-bit Microcontrollers” | <p>Updated the Ohm value for the low-ESR capacitor from less than 5 to less than 1 (see Section 2.3.1 “Internal Regulator Mode”).</p> <p>Labeled the capacitor on the VCAP/VDDCORE pin as CEFC in Figure 2-1.</p> <p>Changed 10 μF capacitor to CEFC capacitor in Section 2.3 “Capacitor on Internal Voltage Regulator (VCAP/VCORE)”.</p> |
| Section 4.0 “Memory Organization” | <p>Updated all register map tables to include the “All Resets” column.</p> <p>Separated the PORT register maps into individual tables (see Table 4-21 through Table 4-34).</p> <p>In addition, formatting changes were made to improve readability.</p> |
| Section 12.0 “I/O Ports” | Updated the second paragraph of Section 12.1.2 “Digital Inputs” and removed Table 12-1. |
| Section 22.0 “10-bit Analog-to-Digital Converter (ADC)” | Updated the ADC Conversion Clock Period Block Diagram (see Figure 22-2). |
| Section 26.0 “Special Features” | Extensive updates were made to Section 26.2 “Watchdog Timer (WDT)” and Section 26.3 “On-Chip Voltage Regulator” . |

PIC32MX3XX/4XX

TABLE A-2: MAJOR SECTION UPDATES (CONTINUED)

| Section Name | Update Description |
|--|---|
| Section 29.0 “Electrical Characteristics” | Updated the Absolute Maximum Ratings and added Note 3. Added Thermal Packaging Characteristics for the 121-pin XBGA package (see Table 29-3). Updated the conditions for parameters DC20, DC21, DC22 and DC23 in Table 29-5. Updated the comments for parameter D321 (CEFC) in Table 29-15. Updated the SPIx Module Slave Mode (CKE = 1) Timing Characteristics, changing SP52 to SP35 between the MSb and Bit 14 on SDOx (see Figure 29-13). |
| Section 30.0 “Packaging Information” | Added the 121-pin XBGA package marking information and package details. |
| “Product Identification System” | Added the definition for BG (121-lead 10x10x1.1 mm, XBGA). Added the definition for Speed. |

Revision H (May 2011)

The revision includes the following global update:

- All references to VDDCORE/VCAP have been changed to: VCORE/VCAP
- Added references to the new V-Temp temperature range: -40°C to +105°C

This revision also includes minor typographical and formatting changes throughout the data sheet text. Major updates are referenced by their respective section in the following table.

TABLE A-3: MAJOR SECTION UPDATES

| Section Name | Update Description |
|--|---|
| Section 1.0 “Device Overview” | Updated the VBUS description in Table 1-1: “Pinout I/O Descriptions” . |
| Section 4.0 “Memory Organization” | <p>Added Note 2 and changed the RIPL<2:0> bits to SRIPL<2:0> in the Interrupt Register Map tables (see Table 4-2 through Table 4-6).</p> <p>Added Note 2 to the Timer1-5 Register Map (see Table 4-7).</p> <p>Updated the All Resets value for I2C1CON<15:0> and I2C2CON<15:0> in the I2C1 and I2C2 Register Map (see Table 4-10).</p> <p>Updated the All Resets value for SPI1STAT<15:0> and SPI2STAT<15:0> in the SPI1 and SPI2 Register Map (see Table 4-12).</p> <p>Updated the All Resets value for CM1CON<15:0> and CM2CON<15:0> in the Comparator Register Map (see Table 4-17).</p> <p>Renamed the RCDIV<2:0> bits to FRCDIV<2:0> and the LOCK bit to SLOCK in the OSCCON register, and added Note 3 and the SYSKEY register to the System Control Registers Map (see Table 4-20).</p> <p>Updated the All Resets value for the PMSTAT register in the Parallel Master Port Register Map (see Table 4-37).</p> <p>Updated the All Resets value for CHECON<15:0> and CHETAG<15:0> in the Prefetch Register Map (see Table 4-39).</p> <p>Renamed FUPPLEN, FUPLLIDIV, and FPLLMULT in the DEVCFG2 register to: UPLEN, UPLLIDIV, and FPLLMUL, respectively in the Device Configuration Word Summary (see Table 4-41).</p> <p>Added Notes 1 through 4 to the USB Register Map (see Table 4-43).</p> |
| Section 5.0 “Flash Program Memory” | Added a note on Flash LVD Delay and Example 5-1 . |
| Section 8.0 “Oscillator Configuration” | Updated the PIC32MX3XX/4XX Family Clock Diagram (see Figure 8-1). |
| Section 11.0 “USB On-The-Go (OTG)” | Updated the PIC32MX3XX/4XX Family USB Interface Diagram (see Figure 11-1). |
| Section 16.0 “Output Compare” | Updated the Output Compare Module Block Diagram (see Figure 16-1). |
| Section 22.0 “10-bit Analog-to-Digital Converter (ADC)” | Updated the ADC Conversion Clock Period Block Diagram (see Figure 22-2). |
| Section 26.0 “Special Features” | Renamed FUPPLEN, FUPLLIDIV, and FPLLMULT in the DEVCFG2 register to: UPLEN, UPLLIDIV, and FPLLMUL, respectively (see Register 26-3). |

PIC32MX3XX/4XX

TABLE A-3: MAJOR SECTION UPDATES (CONTINUED)

| Section Name | Update Description |
|---|--|
| <p>Section 29.0 “Electrical Characteristics”</p> | <p>Added the new V-Temp temperature range (-40°C to +105°C) to the heading of all specification tables.</p> <p>Updated the Ambient temperature under bias, updated the Voltage on any 5V tolerant pin with respect to V_{SS} when V_{DD} < 2.3V, and added Voltage on V_{BUS} with respect to V_{SS} in Absolute Maximum Ratings.</p> <p>Added the characteristic, DC5a to Operating MIPS vs. Voltage (see Table 29-1).</p> <p>Updated or added the following parameters to the Operating Current (I_{DD}) DC Characteristics: DC20, DC23, DC24c, DC25d, DC26c (see Table 29-5).</p> <p>Added the following parameters to the Idle Current (I_{IDLE}) DC Characteristics: DC30c, DC31c, DC32c, DS33c, DC34c, DC35c, and DC36c (see Table 29-6).</p> <p>Added the following parameters to the Power-down Current (I_{PD}) DC Characteristics: DC40g, DC40h, DC40i, DC41g, DC41h, DC42g, DC42h, DC42i, DC43h, and DC43i (see Table 29-7).</p> <p>Added the Brown-out Reset (BOR) Electrical Characteristics (see Table 29-10).</p> <p>Removed all Conditions from the Program Memory DC Characteristics (see Table 29-11).</p> <p>Removed the AC Characteristics voltage reference table (Table 29-15).</p> <p>Added Note 2 to the PLL Clock Timing Specifications (see Table 29-18).</p> <p>Updated the OC/PWM Module Timing Characteristics (see Figure 29-9).</p> <p>Added parameter IM51 and Note 3 to the I²Cx Bus Data Timing Requirements (Master Mode) (see Table 29-32).</p> <p>Added parameter numbers (AD13, AD14, and AD15) to the ADC Module Specifications (see Table 29-34).</p> <p>Updated the 10-bit ADC Conversion Rate Parameters (see Table 29-35).</p> <p>Updated parameter AD57 (TSAMP) in the Analog-to-Digital Conversion Timing Requirements (see Table 29-36).</p> <p>Updated the Conditions for parameters USB313, USB318, and USB319 in the OTG Electrical Specifications (see Table 29-40).</p> |
| <p>Section 30.0 “Packaging Information”</p> | <p>Updated the 64-Lead Plastic Quad Flat, No Lead Package (MR) – 9x9x0.9 mm Body [QFN] packing diagram.</p> |
| <p>Product Identification System</p> | <p>Added the new V-Temp (V) temperature information.</p> |

INDEX

A

| | |
|--|-----|
| AC Characteristics | 161 |
| Internal RC Accuracy | 163 |
| AC Electrical Specifications | |
| Parallel Master Port Read Requirements | 186 |
| Parallel Master Port Write Requirements..... | 187 |
| Parallel Slave Port Requirements | 185 |
| Assembler | |
| MPASM Assembler..... | 148 |

B

| | |
|--|-------------|
| Block Diagrams | |
| ADC Module..... | 123 |
| Comparator I/O Operating Modes..... | 125 |
| Comparator Voltage Reference | 127 |
| Connections for On-Chip Voltage Regulator..... | 138 |
| Input Capture | 107 |
| JTAG Compliant Application Showing | |
| Daisy-Chaining of Components | 139 |
| Output Compare Module..... | 109 |
| Reset System..... | 87 |
| RTCC | 121 |
| Type B Timer | 37, 95, 105 |
| UART | 115 |
| WDT..... | 137 |
| Brown-out Reset (BOR) | |
| and On-Chip Voltage Regulator..... | 138 |

C

| | |
|--|--------|
| C Compilers | |
| MPLAB C18 | 148 |
| Comparator | |
| Operation | 126 |
| Comparator Voltage Reference | |
| Configuring..... | 128 |
| CPU Module..... | 31, 37 |
| Customer Change Notification Service | 209 |
| Customer Notification Service..... | 209 |
| Customer Support..... | 209 |

D

| | |
|--|-----|
| DC Characteristics | 152 |
| I/O Pin Input Specifications..... | 157 |
| I/O Pin Output Specifications..... | 158 |
| Idle Current (IDLE) | 154 |
| Operating Current (IDD)..... | 153 |
| Power-Down Current (IPD) | 155 |
| Program Memory | 159 |
| Temperature and Voltage Specifications | 152 |
| Development Support | 147 |

E

| | |
|---------------------------------|-----|
| Electrical Characteristics..... | 151 |
| AC..... | 161 |
| Errata | 19 |

F

| | |
|----------------------------|----|
| Flash Program Memory | 85 |
| RTSP Operation..... | 85 |

I

| | |
|-------------------------|----------|
| I/O Ports..... | 101, 115 |
| Parallel I/O (PIO)..... | 102 |
| Internet Address..... | 209 |

M

| | |
|---|-----|
| Microchip Internet Web Site..... | 209 |
| MPLAB ASM30 Assembler, Linker, Librarian..... | 148 |
| MPLAB Integrated Development Environment Software.. | 147 |
| MPLAB PM3 Device Programmer | 150 |
| MPLAB REAL ICE In-Circuit Emulator System | 149 |
| MPLINK Object Linker/MPLIB Object Librarian | 148 |

P

| | |
|--|-----|
| Packaging | 191 |
| Details..... | 192 |
| Marking..... | 191 |
| PIC32 Family USB Interface Diagram | 100 |
| Pinout I/O Descriptions (table)..... | 22 |
| Power-on Reset (POR) | |
| and On-Chip Voltage Regulator | 138 |

R

| | |
|----------------------|-----|
| Reader Response..... | 210 |
|----------------------|-----|

S

| | |
|---------------------------------------|----------------------------|
| Serial Peripheral Interface (SPI) ... | 87, 97, 111, 119, 121, 130 |
| Software Simulator (MPLAB SIM) | 149 |
| Special Features..... | 131 |

T

| | |
|---|------------------|
| Timer1 Module..... | 89, 95, 103, 105 |
| Timing Diagrams | |
| 10-bit Analog-to-Digital Conversion (CHPS<1:0> = 01, SIMSAM = 0, ASAM = 0, SSRC<2:0> = 000) .. | 183 |
| 10-bit Analog-to-Digital Conversion (CHPS<1:0> = 01, SIMSAM = 0, ASAM = 1, SSRC<2:0> = 111, SAMC<4:0> = 00001)..... | 184 |
| I2Cx Bus Data (Master Mode) | 175 |
| I2Cx Bus Data (Slave Mode) | 177 |
| I2Cx Bus Start/Stop Bits (Master Mode)..... | 175 |
| I2Cx Bus Start/Stop Bits (Slave Mode)..... | 177 |
| Input Capture (CAPx) | 169 |
| OC/PWM | 170 |
| Output Compare (OCx) | 169 |
| Parallel Master Port Write..... | 186, 187 |
| Parallel Slave Port | 185 |
| SPIx Master Mode (CKE = 0) | 171 |
| SPIx Master Mode (CKE = 1) | 172 |
| SPIx Slave Mode (CKE = 0) | 173 |
| SPIx Slave Mode (CKE = 1) | 174 |
| Timer1, 2, 3, 4, 5 External Clock | 167 |
| Transmission (8-bit or 9-bit Data) | 116 |
| UART Reception with Receive Overrun | 117 |
| Timing Requirements | |
| CLKO and I/O | 164 |
| Timing Specifications | |
| I2Cx Bus Data Requirements (Master Mode)..... | 175 |
| I2Cx Bus Data Requirements (Slave Mode)..... | 178 |
| Output Compare Requirements..... | 169 |
| Simple OC/PWM Mode Requirements | 170 |
| SPIx Master Mode (CKE = 0) Requirements..... | 171 |
| SPIx Master Mode (CKE = 1) Requirements..... | 172 |
| SPIx Slave Mode (CKE = 1) Requirements..... | 174 |

V

| | |
|---------------------------------------|-----|
| VCORE/VCAP Pin | 138 |
| Voltage Reference Specifications..... | 160 |
| Voltage Regulator (On-Chip) | 138 |

PIC32MX3XX/4XX

W

| | |
|---------------------------|-----|
| Watchdog Timer | |
| Operation | 137 |
| WWW Address..... | 209 |
| WWW, On-Line Support..... | 19 |

THE MICROCHIP WEB SITE

Microchip provides online support via our WWW site at www.microchip.com. This web site is used as a means to make files and information easily available to customers. Accessible by using your favorite Internet browser, the web site contains the following information:

- **Product Support** – Data sheets and errata, application notes and sample programs, design resources, user's guides and hardware support documents, latest software releases and archived software
- **General Technical Support** – Frequently Asked Questions (FAQs), technical support requests, online discussion groups, Microchip consultant program member listing
- **Business of Microchip** – Product selector and ordering guides, latest Microchip press releases, listing of seminars and events, listings of Microchip sales offices, distributors and factory representatives

CUSTOMER CHANGE NOTIFICATION SERVICE

Microchip's customer notification service helps keep customers current on Microchip products. Subscribers will receive e-mail notification whenever there are changes, updates, revisions or errata related to a specified product family or development tool of interest.

To register, access the Microchip web site at www.microchip.com. Under "Support", click on "Customer Change Notification" and follow the registration instructions.

CUSTOMER SUPPORT

Users of Microchip products can receive assistance through several channels:

- Distributor or Representative
- Local Sales Office
- Field Application Engineer (FAE)
- Technical Support
- Development Systems Information Line

Customers should contact their distributor, representative or field application engineer (FAE) for support. Local sales offices are also available to help customers. A listing of sales offices and locations is included in the back of this document.

Technical support is available through the web site at: <http://microchip.com/support>

PIC32MX3XX/4XX

READER RESPONSE

It is our intention to provide you with the best documentation possible to ensure successful use of your Microchip product. If you wish to provide your comments on organization, clarity, subject matter, and ways in which our documentation can better serve you, please FAX your comments to the Technical Publications Manager at (480) 792-4150.

Please list the following information, and use this outline to provide us with your comments about this document.

TO: Technical Publications Manager Total Pages Sent _____

RE: Reader Response

From: Name _____

Company _____

Address _____

City / State / ZIP / Country _____

Telephone: (_____) _____ - _____ FAX: (_____) _____ - _____

Application (optional):

Would you like a reply? Y N

Device: PIC32MX3XX/4XX

Literature Number: DS61143H

Questions:

1. What are the best features of this document?

2. How does this document meet your hardware and software development needs?

3. Do you find the organization of this document easy to follow? If not, why?

4. What additions to the document do you think would enhance the structure and subject?

5. What deletions from the document could be made without affecting the overall usefulness?

6. Is there any incorrect or misleading information (what and where)?

7. How would you improve this document?

Product Identification System

To order or obtain information, e.g., on pricing or delivery, refer to the factory or the listed sales office.

| | | |
|---|--|--|
| | PIC32 MX 3XX F 512 H T - 80 I / PT - XXX | |
| Microchip Brand _____ | | Examples: PIC32MX320F032H-40I/PT: General purpose PIC32MX, 32 KB program memory, 64-pin, Industrial temperature, TQFP package. PIC32MX360F256L-80I/PT: General purpose PIC32MX, 256 KB program memory, 100-pin, Industrial temperature, TQFP package. |
| Architecture _____ | | |
| Product Groups _____ | | |
| Flash Memory Family _____ | | |
| Program Memory Size (KB) _____ | | |
| Pin Count _____ | | |
| Tape and Reel Flag (if applicable) _____ | | |
| Speed _____ | | |
| Temperature Range _____ | | |
| Package _____ | | |
| Pattern _____ | | |
| Flash Memory Family | | |
| Architecture | MX = 32-bit RISC MCU core | |
| Product Groups | 3XX = General purpose microcontroller family 4XX = USB | |
| Flash Memory Family | F = Flash program memory | |
| Program Memory Size | 32 = 32K 64 = 64K 128 = 128K 256 = 256K 512 = 512K | |
| Speed | 40 = 40 MHz 80 = 80 MHz | |
| Pin Count | H = 64-pin L = 100-pin | |
| Temperature Range | I = -40°C to +85°C (Industrial) V = -40°C to +105°C (V-Temp) | |
| Package | PT = 64-Lead (10x10x1 mm) TQFP (Thin Quad Flatpack) PT = 100-Lead (12x12x1 mm) TQFP (Thin Quad Flatpack) MR = 64-Lead (9x9x0.9 mm) QFN (Plastic Quad Flat) BG = 121-Lead (10x10x1.1 mm) XBGA (Plastic Thin Profile Ball Grid Array) | |
| Pattern | Three-digit QTP, SQTP, Code or Special Requirements (blank otherwise) ES = Engineering Sample | |



MICROCHIP

Worldwide Sales and Service

AMERICAS

Corporate Office
2355 West Chandler Blvd.
Chandler, AZ 85224-6199
Tel: 480-792-7200
Fax: 480-792-7277
Technical Support:
<http://www.microchip.com/support>
Web Address:
www.microchip.com

Atlanta
Duluth, GA
Tel: 678-957-9614
Fax: 678-957-1455

Boston
Westborough, MA
Tel: 774-760-0087
Fax: 774-760-0088

Chicago
Itasca, IL
Tel: 630-285-0071
Fax: 630-285-0075

Cleveland
Independence, OH
Tel: 216-447-0464
Fax: 216-447-0643

Dallas
Addison, TX
Tel: 972-818-7423
Fax: 972-818-2924

Detroit
Farmington Hills, MI
Tel: 248-538-2250
Fax: 248-538-2260

Indianapolis
Noblesville, IN
Tel: 317-773-8323
Fax: 317-773-5453

Los Angeles
Mission Viejo, CA
Tel: 949-462-9523
Fax: 949-462-9608

Santa Clara
Santa Clara, CA
Tel: 408-961-6444
Fax: 408-961-6445

Toronto
Mississauga, Ontario,
Canada
Tel: 905-673-0699
Fax: 905-673-6509

ASIA/PACIFIC

Asia Pacific Office
Suites 3707-14, 37th Floor
Tower 6, The Gateway
Harbour City, Kowloon
Hong Kong
Tel: 852-2401-1200
Fax: 852-2401-3431

Australia - Sydney
Tel: 61-2-9868-6733
Fax: 61-2-9868-6755

China - Beijing
Tel: 86-10-8569-7000
Fax: 86-10-8528-2104

China - Chengdu
Tel: 86-28-8665-5511
Fax: 86-28-8665-7889

China - Chongqing
Tel: 86-23-8980-9588
Fax: 86-23-8980-9500

China - Hangzhou
Tel: 86-571-2819-3180
Fax: 86-571-2819-3189

China - Hong Kong SAR
Tel: 852-2401-1200
Fax: 852-2401-3431

China - Nanjing
Tel: 86-25-8473-2460
Fax: 86-25-8473-2470

China - Qingdao
Tel: 86-532-8502-7355
Fax: 86-532-8502-7205

China - Shanghai
Tel: 86-21-5407-5533
Fax: 86-21-5407-5066

China - Shenyang
Tel: 86-24-2334-2829
Fax: 86-24-2334-2393

China - Shenzhen
Tel: 86-755-8203-2660
Fax: 86-755-8203-1760

China - Wuhan
Tel: 86-27-5980-5300
Fax: 86-27-5980-5118

China - Xian
Tel: 86-29-8833-7252
Fax: 86-29-8833-7256

China - Xiamen
Tel: 86-592-2388138
Fax: 86-592-2388130

China - Zhuhai
Tel: 86-756-3210040
Fax: 86-756-3210049

ASIA/PACIFIC

India - Bangalore
Tel: 91-80-3090-4444
Fax: 91-80-3090-4123

India - New Delhi
Tel: 91-11-4160-8631
Fax: 91-11-4160-8632

India - Pune
Tel: 91-20-2566-1512
Fax: 91-20-2566-1513

Japan - Yokohama
Tel: 81-45-471- 6166
Fax: 81-45-471-6122

Korea - Daegu
Tel: 82-53-744-4301
Fax: 82-53-744-4302

Korea - Seoul
Tel: 82-2-554-7200
Fax: 82-2-558-5932 or
82-2-558-5934

Malaysia - Kuala Lumpur
Tel: 60-3-6201-9857
Fax: 60-3-6201-9859

Malaysia - Penang
Tel: 60-4-227-8870
Fax: 60-4-227-4068

Philippines - Manila
Tel: 63-2-634-9065
Fax: 63-2-634-9069

Singapore
Tel: 65-6334-8870
Fax: 65-6334-8850

Taiwan - Hsin Chu
Tel: 886-3-6578-300
Fax: 886-3-6578-370

Taiwan - Kaohsiung
Tel: 886-7-213-7830
Fax: 886-7-330-9305

Taiwan - Taipei
Tel: 886-2-2500-6610
Fax: 886-2-2508-0102

Thailand - Bangkok
Tel: 66-2-694-1351
Fax: 66-2-694-1350

EUROPE

Austria - Wels
Tel: 43-7242-2244-39
Fax: 43-7242-2244-393

Denmark - Copenhagen
Tel: 45-4450-2828
Fax: 45-4485-2829

France - Paris
Tel: 33-1-69-53-63-20
Fax: 33-1-69-30-90-79

Germany - Munich
Tel: 49-89-627-144-0
Fax: 49-89-627-144-44

Italy - Milan
Tel: 39-0331-742611
Fax: 39-0331-466781

Netherlands - Drunen
Tel: 31-416-690399
Fax: 31-416-690340

Spain - Madrid
Tel: 34-91-708-08-90
Fax: 34-91-708-08-91

UK - Wokingham
Tel: 44-118-921-5869
Fax: 44-118-921-5820

05/02/11