



**ANATECH ELECTRONICS INC**  
RF & Microwave Filters & Products

## 500 KHz LC Band Pass Filter

Part Number: AE500KB5439



### Electrical Specifications

**Center Frequency:** 500 KHz  
**3dB Passband:** 420-596 KHz  
**Insertion Loss:** 4.0dB Max.  
**Rejection1:** 40dB Min @ 355 KHz  
**Rejection2:** 40dB Min @ 704 KHz  
**Power Handling:** 10 W

### Mechanical

**Mounting Method:** Threaded Holes  
**Connector Type:** SMA(F)  
**Dimensions:** 2.38" X 1.0" x 1.0".

### Environmental

**Operating Temperature:** -25°C to +70°C  
**Storage Temperature:** -40°C to +90°C  
**Shock:** 10 G. 11ms  
**Vibration:** 10 G. 5 to 200Hz

### Outline Drawing:

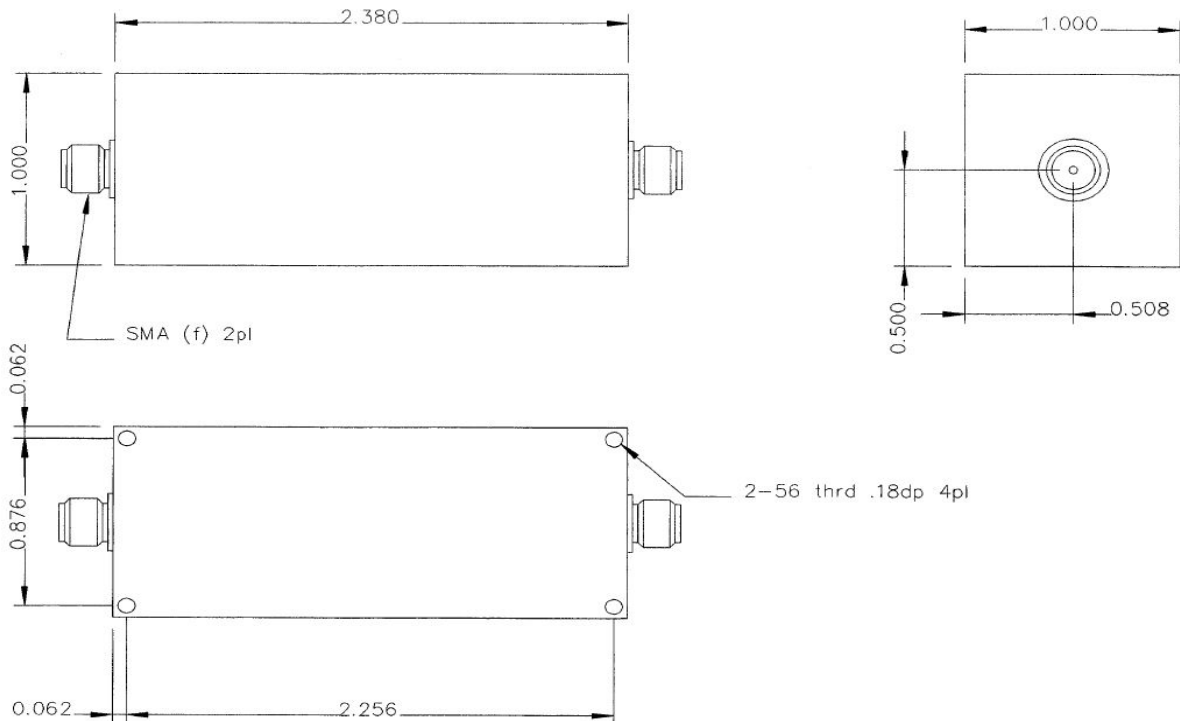

Tolerance: +/-0.01 inches [ +/- 0.3mm]

Angles: +/- 1 Deg.

\*Tolerance as shown unless otherwise specified in the datasheet electrical specification tables above.

\*When max dimensions are called out the above tolerances do not apply as long as it is under the max call out.

70 Outwater Lane Phone: (973) 772-4242  
Garfield, NJ 07026 Fax : (973) 321-3941

Email: [sales@anatechelectronics.com](mailto:sales@anatechelectronics.com)  
Web: [www.anatechelectronics.com](http://www.anatechelectronics.com)



### Simulation Plot:

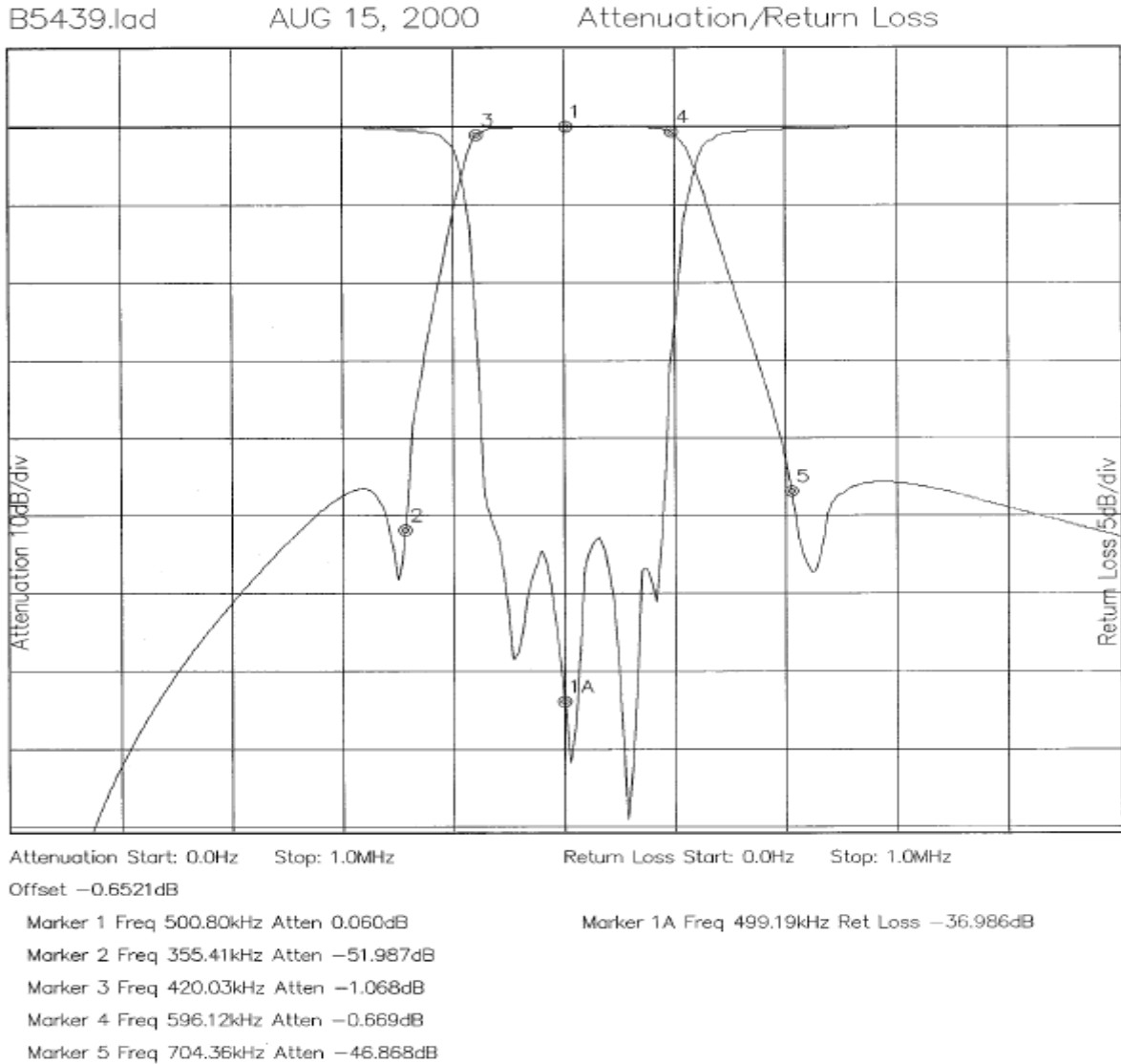

Note: This is a simulated response plot. Actual performance might differ.